

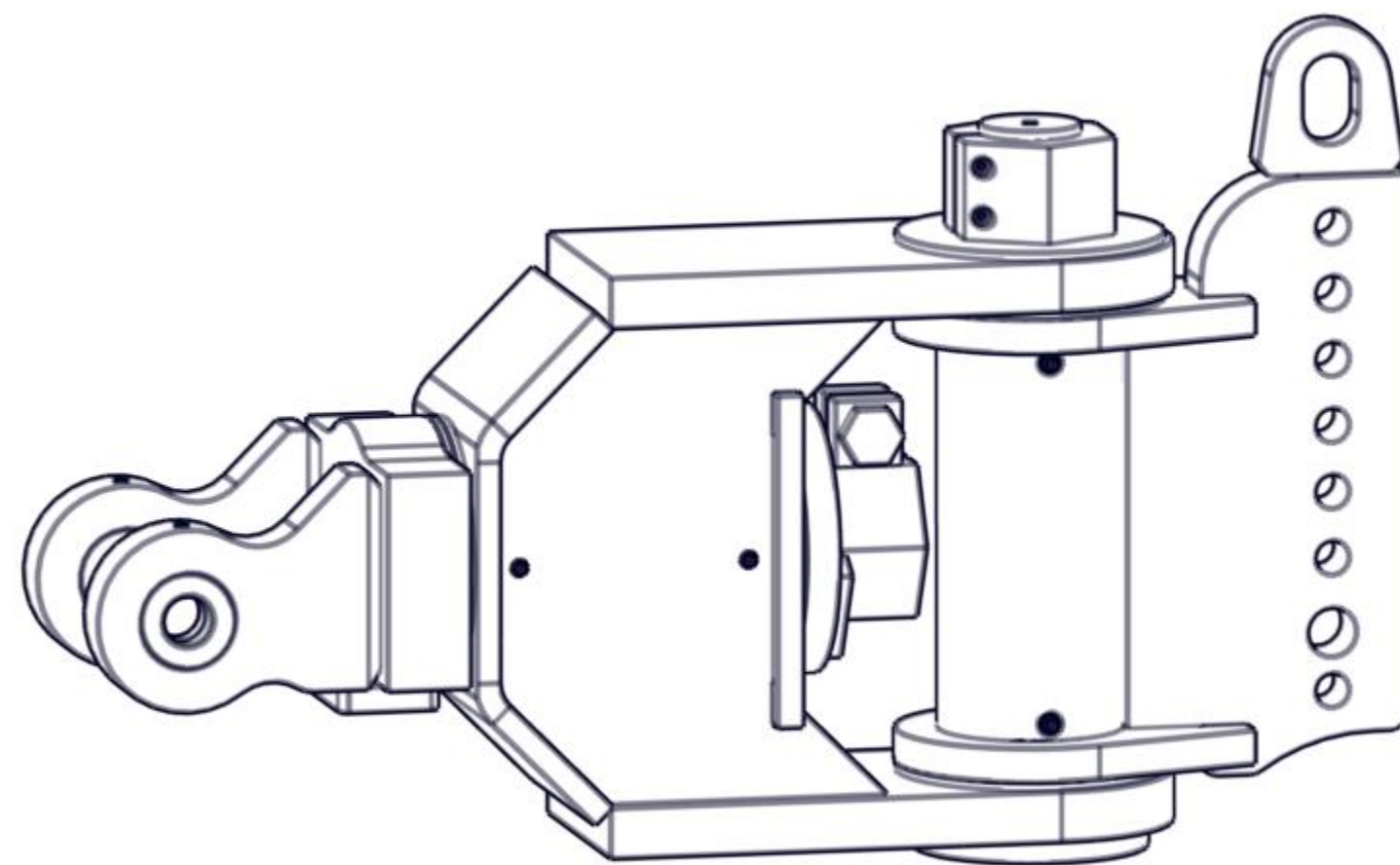

# Parts Manual

# Scraper Hitches



2-21

*Address*

1115 Rail Drive  
PO BOX 717  
Ashland, WI USA 54806

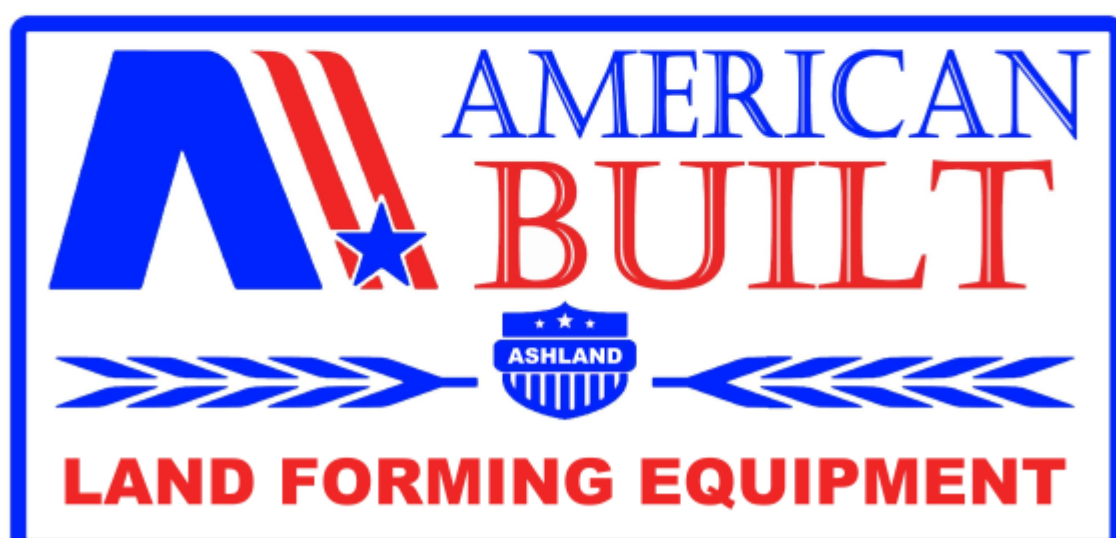

*Toll Free*

(877) 634-4622

*Business*

(715) 682-4622

*Fax*

(715) 682-9717

*Website*

[www.ashlandind.com](http://www.ashlandind.com)

# Table of Contents



A123299 Swivel Hitch	3
A1063527 Super Swivel Hitch	4
A125056 Yoke Hitch	5
A125057 Super Capacity Hitch	6
A125223 MDU Hitch	7
A123224 360 Swivel Hitch	9
601135 Big G Hitch	10
601135 Ashland Hitch (2017)	11
601440 HD Ag. Category 4 Swivel Hitch	12
601135 Ashland Hitch (2020)	13
601689 Ashland Universal Hitch	14

**ALL PARTS SUBJECT TO AVAILABILITY**

# A123299 Swivel Hitch



LAST USED 2002

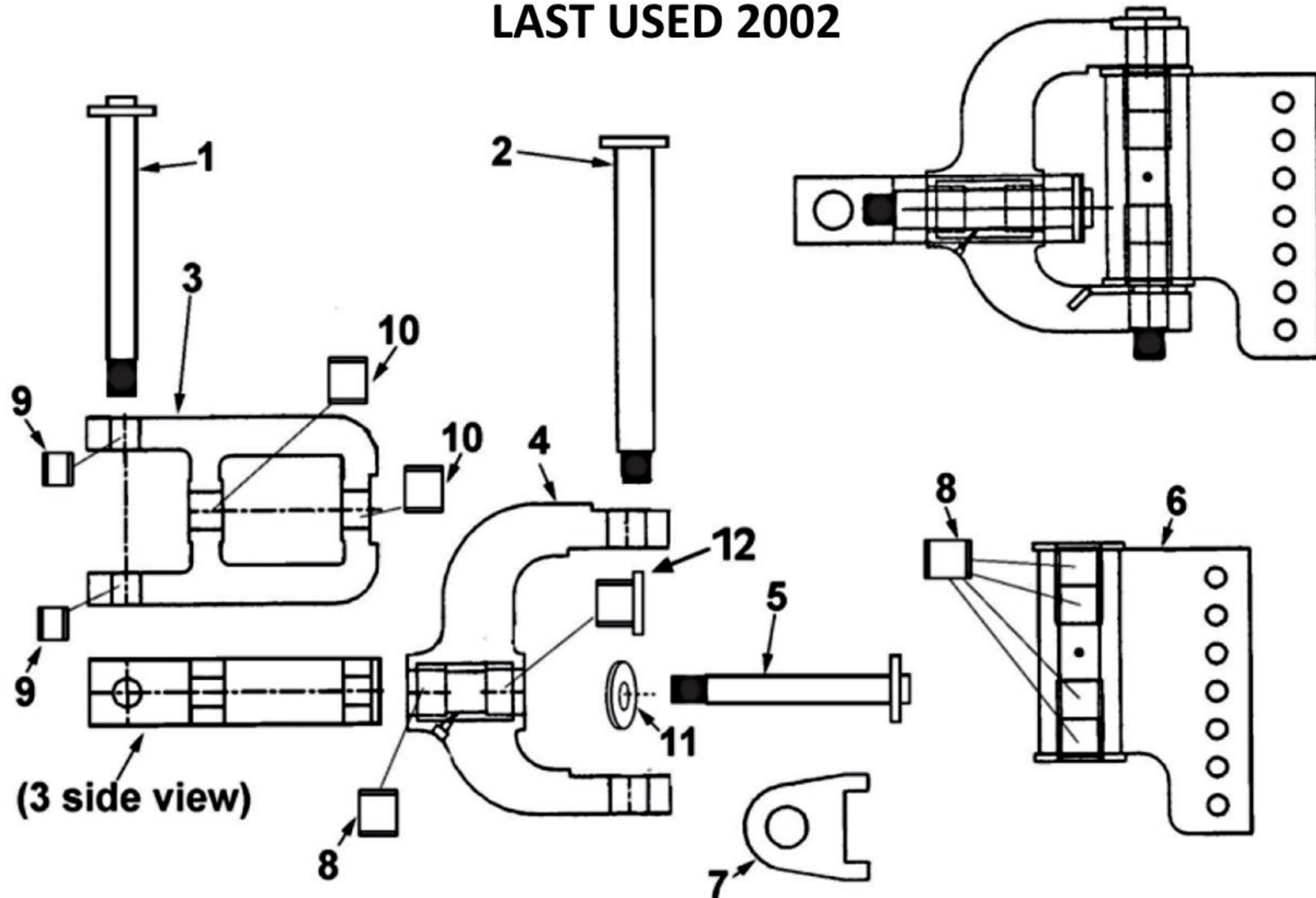

Item	Part Number	Description
1	CNH 84268964	Pin Ass'y.: 1-1/2" Dia. w/ Nut & Cotter Pin
	A123299-07	Pin: Two Ear Drawbar to Hitch
	AFN-00014	Nut: 1-1/2" NC Slotted
2	A123299-06	Pin: Square Tab Head 2" x 18-1/2"
	AFN-00018	Nut: 1-1/2" NF Top Lock
3	A123299-03R	Hitch: A-Frame
4	A123299-02	Hitch: C-Frame Offset
5	A123299-05	Pin: Square Tab Head 2" x 12-1/2"
	AFN-00018	Nut: 1-1/2" NF Top Lock
6	A123299-01	Tube: Vertical Mounting, 7-Hole
7	A123299-04	Pad: Wear w/ Locking Legs
8	ABS-00001	Bushing: Spring 2" ID x 2-3/8" OD
9	A123299-09	Bushing: 2" OD x 1-1/2" ID x 1-1/2" Long (2 Required)
10	A123299-10	Bushing: 2-3/8" OD x 2" ID x 1-1/2" Long (2 Required)
11	AFW-00014	Washer: 2"
12	A123299-14	Bushing: 2" ID x 2-3/8" OD Thrust w/ Flange

# A1063527 Super Swivel Hitch



LAST USED 2003

S.N. 20496 & Above  
Used on scrapers  
until 2003

I-155TS Front & Rear

**IMPORTANT**

Some units prior to this serial number were upgraded to a HD cast type yoke hitch by the customer. Please determine if the entire yoke hitch is cast or flat steel. The cast hitch has "OFCO" cast into the A-Frame hitch

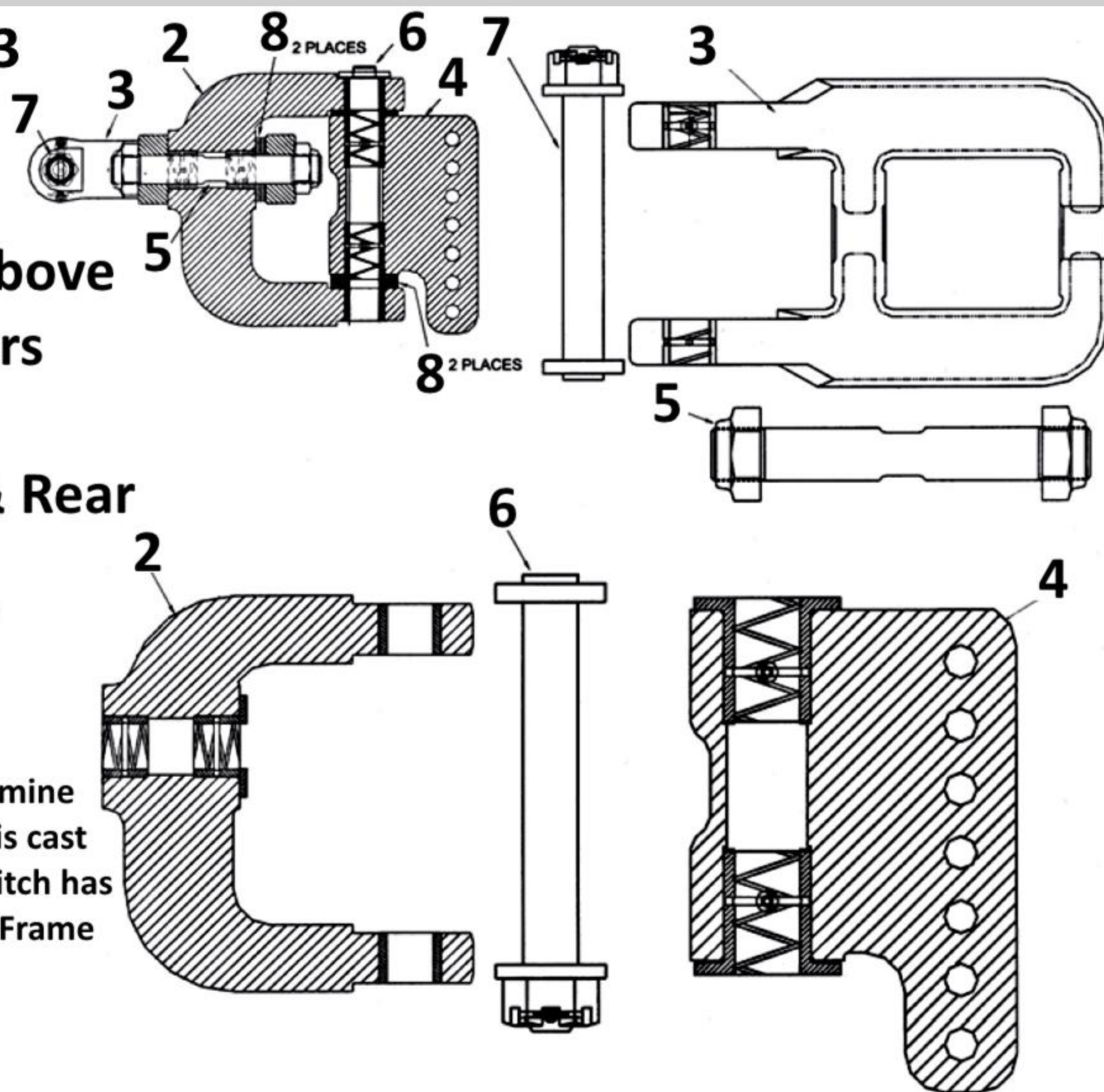

Item	Part Number	Description
2	A1062280	Housing Ass'y.: Rear Super Yoke (1 Required)
	A1063177	Bushing: Housing Ears (2 Required)
	A1063144	Bushing: Center Pivot, Spiral (2 Required)
	14505	Fitting: Grease (2 Required)
3	A1063281	Yoke Ass'y.: Front Super Yoke (1 Required)
	A1063145	Bushing: Yoke Ear, Spiral (2 Required)
	14505	Fitting: Grease (2 Required)
4	A1063282	Bracket Ass'y.: 7-Hole Vertical Pivot (1 Required)
	A1063143	Bushing: Vertical Bracket, Spiral (2 Required)
	14505	Fitting: Grease (2 Required)
5	A1063283	Pin: Horizontal Assembly with Nuts (1 Required)
	A1063212	PIN ONLY (1 Required)
	AFN-00025	Nut: 2" NF (2 Required)
6	A1063284	Pin Ass'y.: Vertical w/ Nut, Washer, Cotter Pin (1 Required)
	A1063214	PIN ONLY (1 Required)
	A1063259	Washer: Vertical Pin (1 Required)
	AFN-00021	Nut: 1-1/2" NC Slotted
	AFP-00014	Pin: 3/8" x 4" Cotter
7	CNH 84268964	Pin Ass'y.: 1-1/2" Dia. w/ Nut & Cotter Pin (1 Required)
8	A1063146	Washer: Thrust (4 Required)

# A125056 Yoke Hitch



FIRST USED 2003 - LAST USED 2007

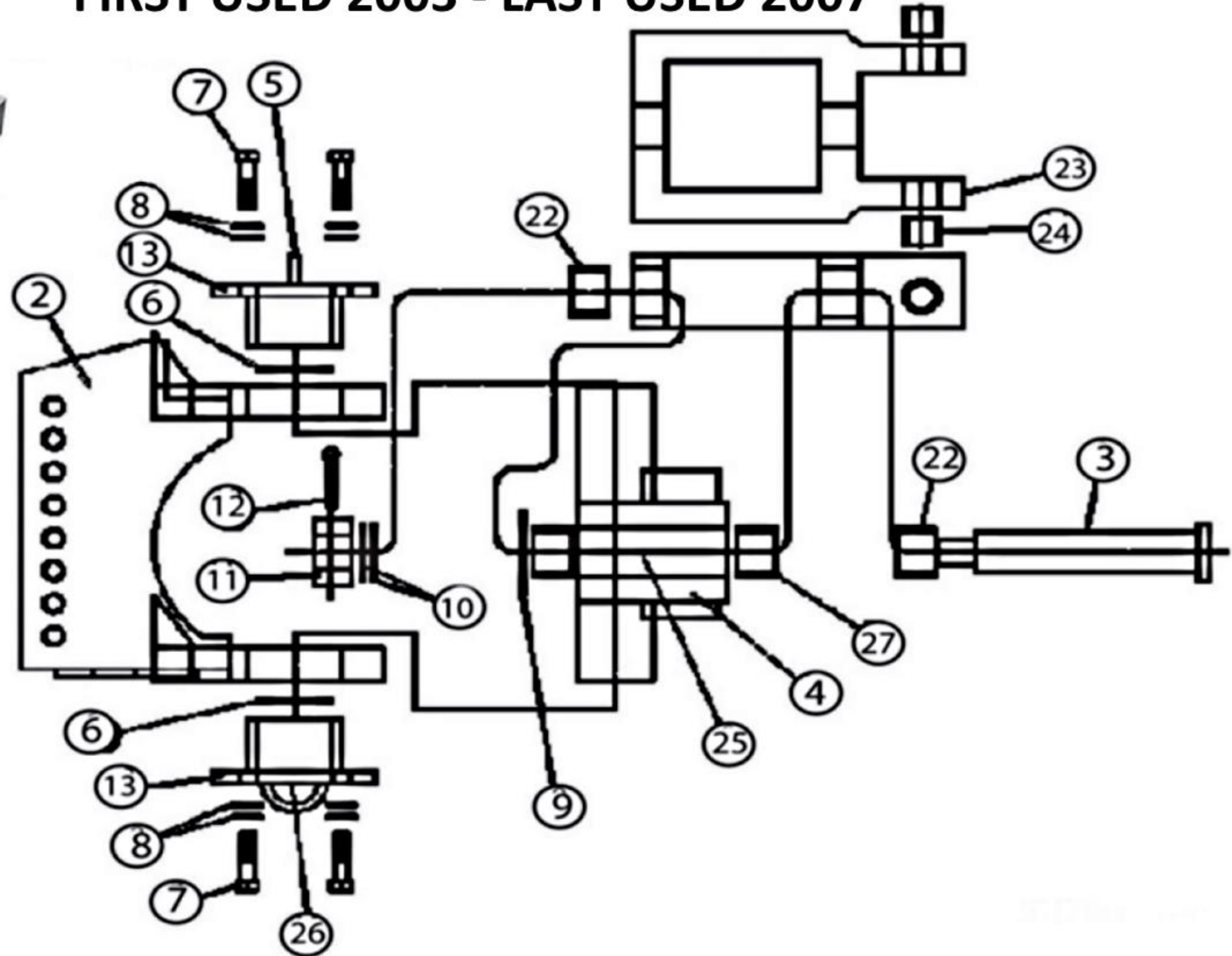
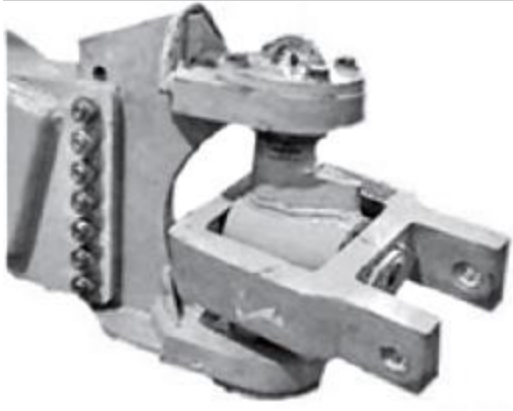

Item	Part Number	Description
2	A125056-02	Bracket: Hitch MDU 7-Hole
3	A125223-06	Pin: Horizontal MDU
4	A125056-25	Swivel Ass'y.: MDU Center
5	A125057-13	Cap: Swivel
6	A125056-06	Washer: Swivel Cap
7	AFB-00064	HHCS: 3/4" NC x 3"
8	AFW-00024	Washer: 3/4" Hardened
9	A125056-09	Washer: 2-1/2" Hardened
10	A125056-10	Washer: 1-1/2" Hardened
11	AFN-00014	Nut: 1-1/2" NC Slotted
12	AFP-00011	Pin: 5/16" x 2-1/2" Cotter
13	A125057-15	Seal: Swivel Cap
22	A125056-22	Bushing: Spring, Yoke Frame
23	A125223-01	Yoke: A-Frame
24	A125056-24	Bushing: Yoke Ears
25	14505	Fitting: Grease
26	AHF-00028	Fitting: 90-Degree Grease
27	A125056-27	Bushing: Center Swivel

# A125057 Super Capacity Hitch



LAST USED 2007

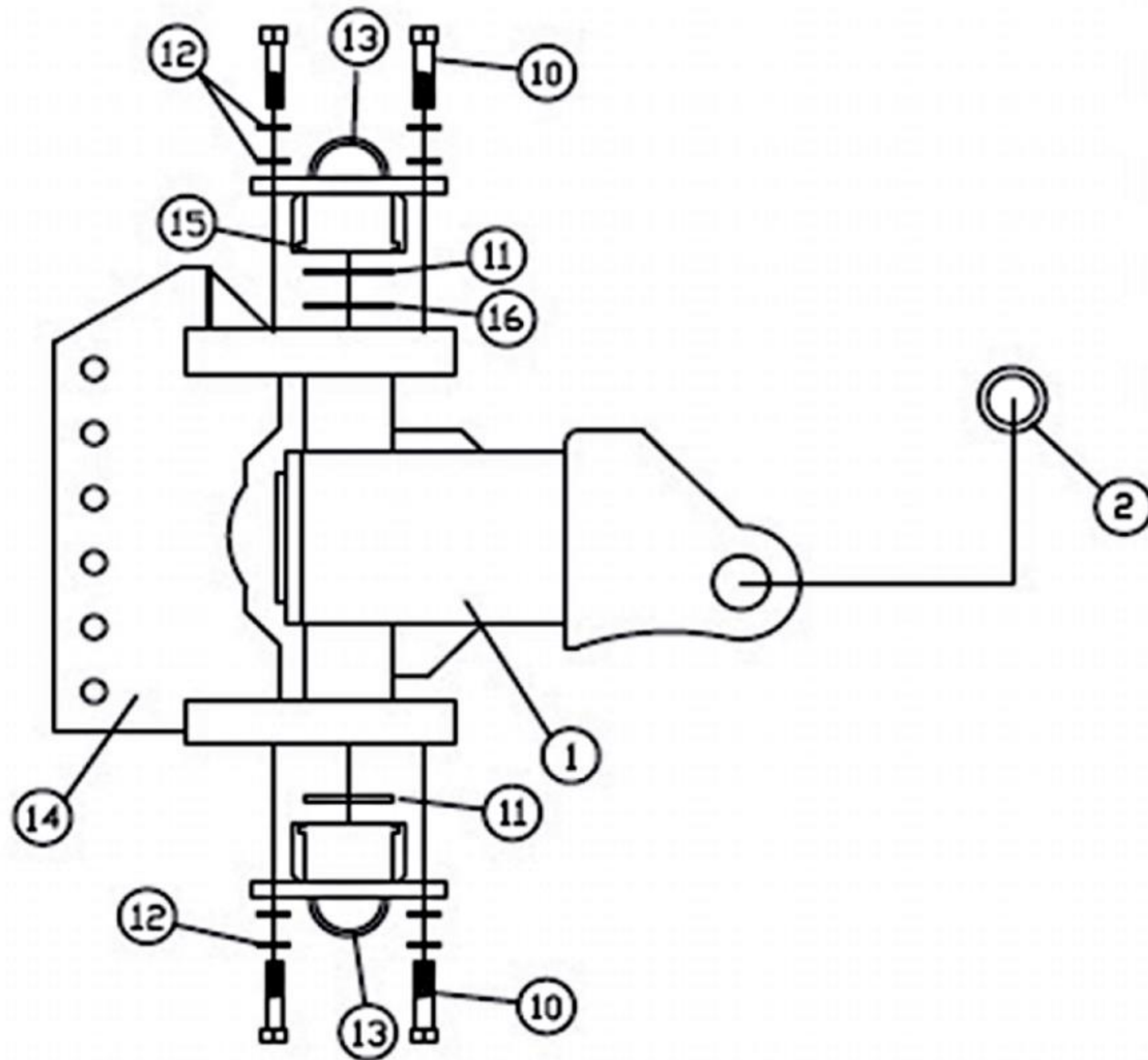

Item	Part Number	Description
1	A125057-01	Yoke: Hitch Swivel
2	A125057-02	Bushing: 1-1/2" ID x 2-3/4" OD
	A125057-02A	Bushing: 1-1/2" ID x 2-1/2" OD
10	AFB-00064	HHCS: 3/4" NC x 3"
11	A125056-06	Washer: Swivel Cap
12	AFW-00007	Washer: 3/4" Flat
13	A125057-13	Cap: Swivel
14	A125057-14	Bracket: Hitch 360-degree 7-Hole
15	A125057-15	Seal: Swivel Cap
16	A125057-16	Shim: Swivel Cap

# A125223 MDU Hitch



LAST USED 2018

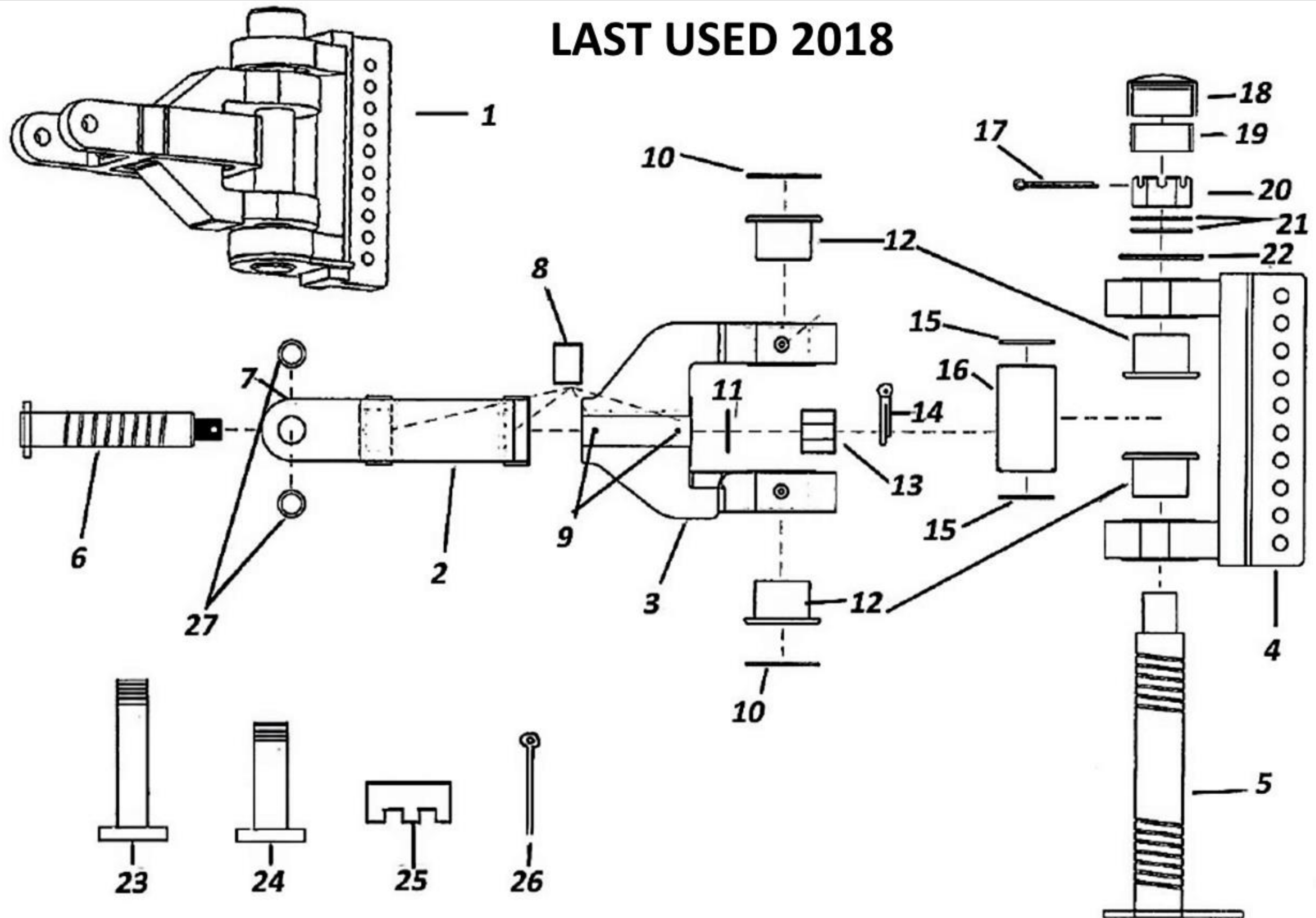

Item	Part Number	Description
1	A125223	Hitch: Cast MDU
2	A125223-01	Yoke: A-Frame
3	A125223-02	Swivel: MDU
4	A125223-03	Bracket: 10-Hole
5	A125223-04	Pin: Main Vertical
6	A125223-06	Pin: Main Horizontal
7	14505	Fitting: Grease
8	A125056-27	Bushing: Center Swivel
9	AHF-00028	Fitting: 90-Degree Grease
10	A125223-08	Seal: 5-7/8" O-Ring
11	A125223-11	Washer: 1-1/2"
12	A125224-07	Bushing: Flanged
13	AFN-00014	Nut: 1-1/2" NC Slotted
14	AFP-00011	Pin: 5/16" x 2-1/2" Cotter
15	A125223-09	Seal: 4" O-Ring
16	A125223-05	Spacer: 6" Tube
17	AFP-00012	Pin: 3/8" x 5" Cotter
18	A125223-17	Cap: 4" Cover
19	A125223-16	Sleeve: 2" Rubber
20	AFN-00072	Nut: 2-1/2" NC

# A125223 MDU Hitch (cont'd)



LAST USED 2018

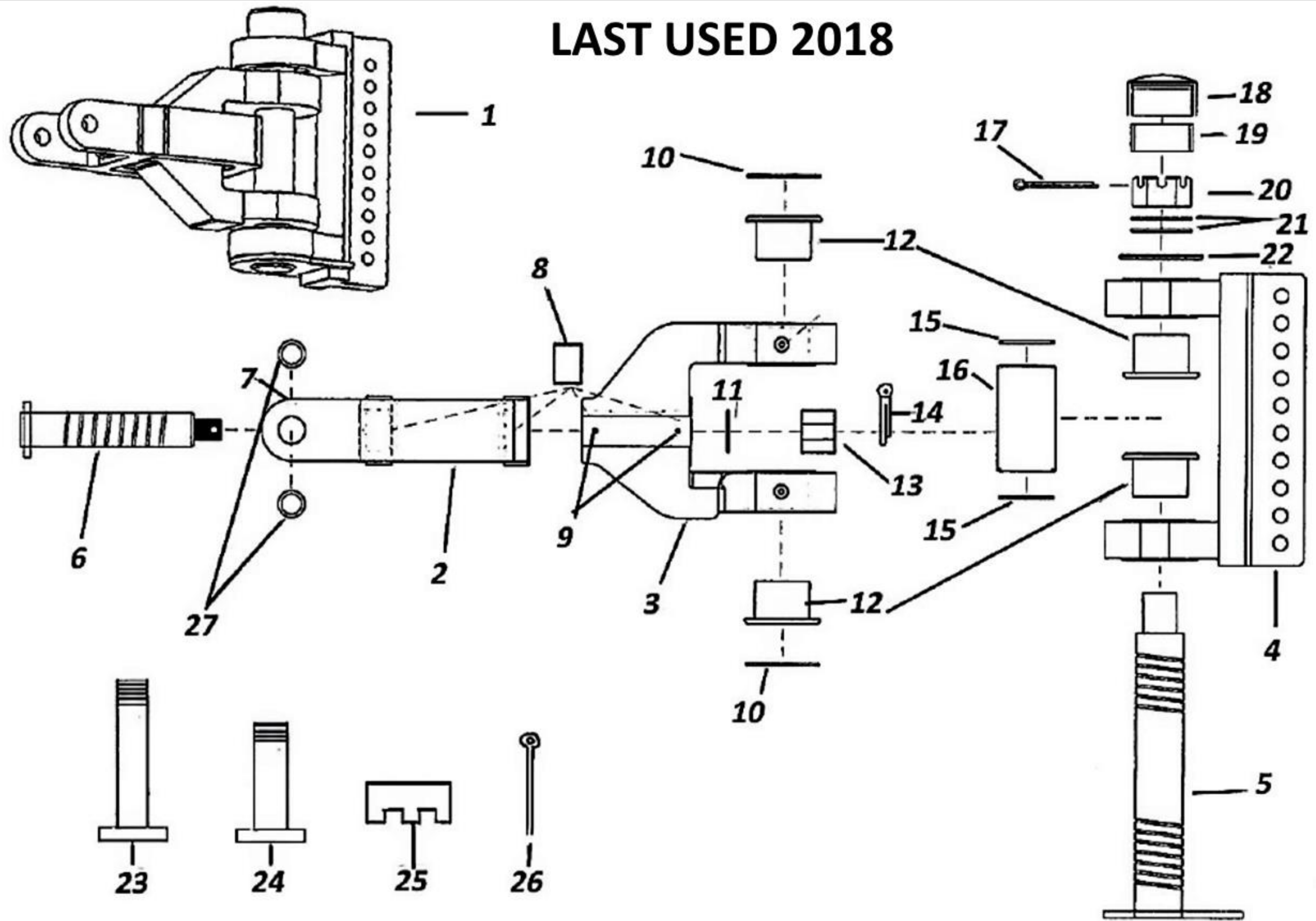

Item	Part Number	Description
21	A125223-14	Washer: 2-1/2" Hardened
22	A125223-13	Spacer: 6"
23	CNH 84268964	Pin Ass'y.: 1-1/2" Dia. w/ Nut & Cotter Pin
24	A123299-07	Pin: Two Ear Drawbar to Hitch
25	AFN-00014	Nut: 1-1/2" NC Slotted
26	AFP-00001	Pin: 1/4" x 3" Cotter
27	A125056-24	Bushing: Yoke Ears

# A125224 360 Swivel Hitch



LAST USED 2017

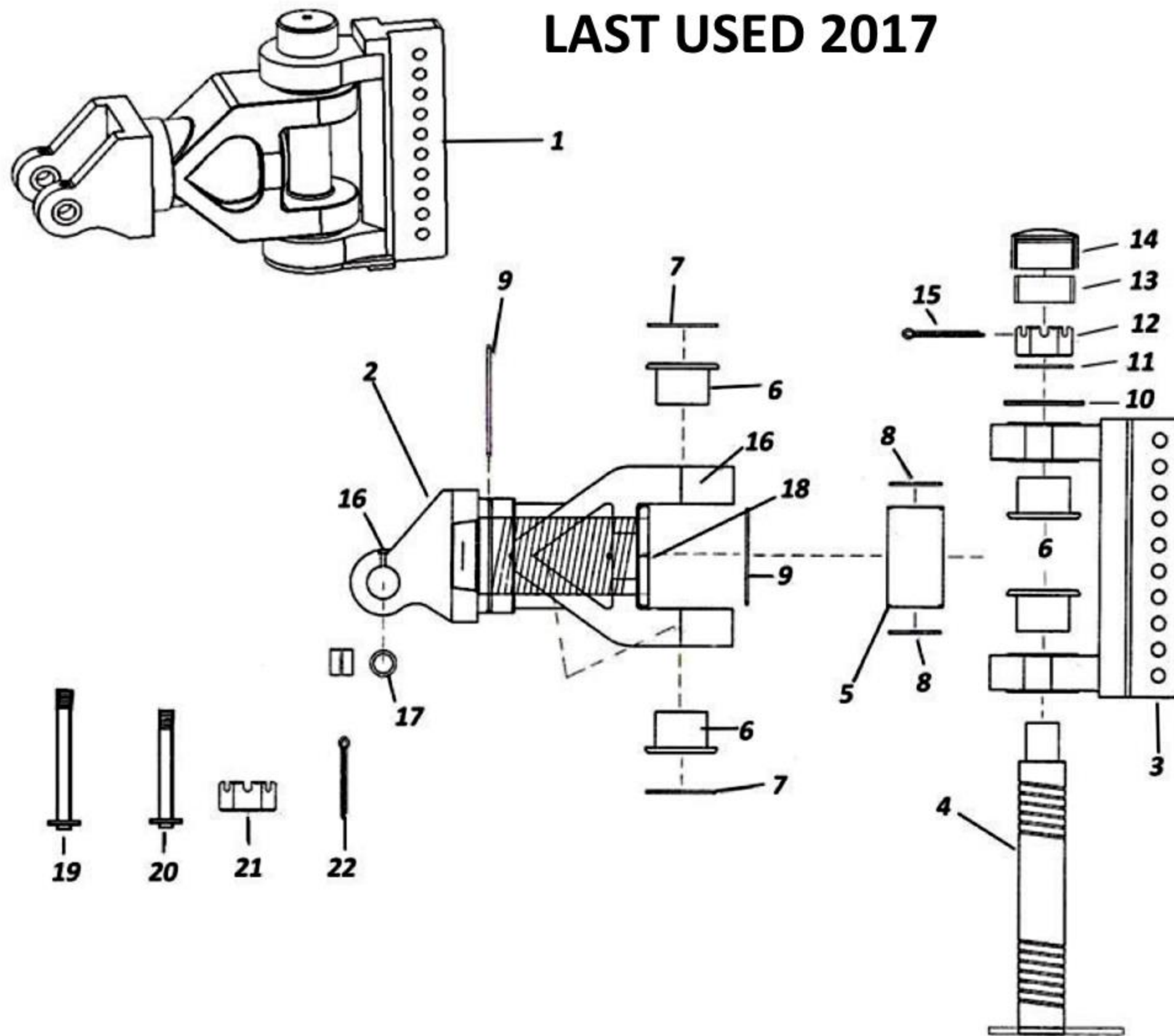

Item	Part Number	Description
1	A125224	Hitch: 360 Cast
2	A125224-01	Yoke: Swivel
3	A125224-03	Bracket: 10-Hole
4	A125224-04	Pin: Main Vertical
5	A125224-05	Spacer: Tube
6	A125224-07	Bushing: Flanged
7	A125224-08	O-Ring: 5-7/8"
8	A125224-09	O-Ring: 4"
9	A125224-10	O-Ring: 8-7/8"
10	A125224-13	Spacer: 6"
11	AFW-00035	Washer: 2-1/2"
12	A125224-15	Nut: 2-1/2" NC Slotted
13	A125224-16	Spacer: 2" Rubber
14	A125224-17	Cap: 4" Swivel
15	AFP-00012	Pin: 3/8" x 5" Cotter
16	14505	Fitting: Grease
17	A125057-02A	Bushing: 1-1/2" ID x 2-1/2" OD
18	AHF-00027	Fitting: 45-Degree Grease
19	CNH 84268964	Pin Ass'y.: 1-1/2" Dia. w/ Nut & Cotter Pin
20	A123299-07	Pin: Two Ear Drawbar to Hitch
21	AFN-00014	Nut: 1-1/2" NC Slotted
22	AFP-00001	Pin: 1/4" x 3" Cotter

# 601135 Big G Hitch



**LAST USED  
2017**

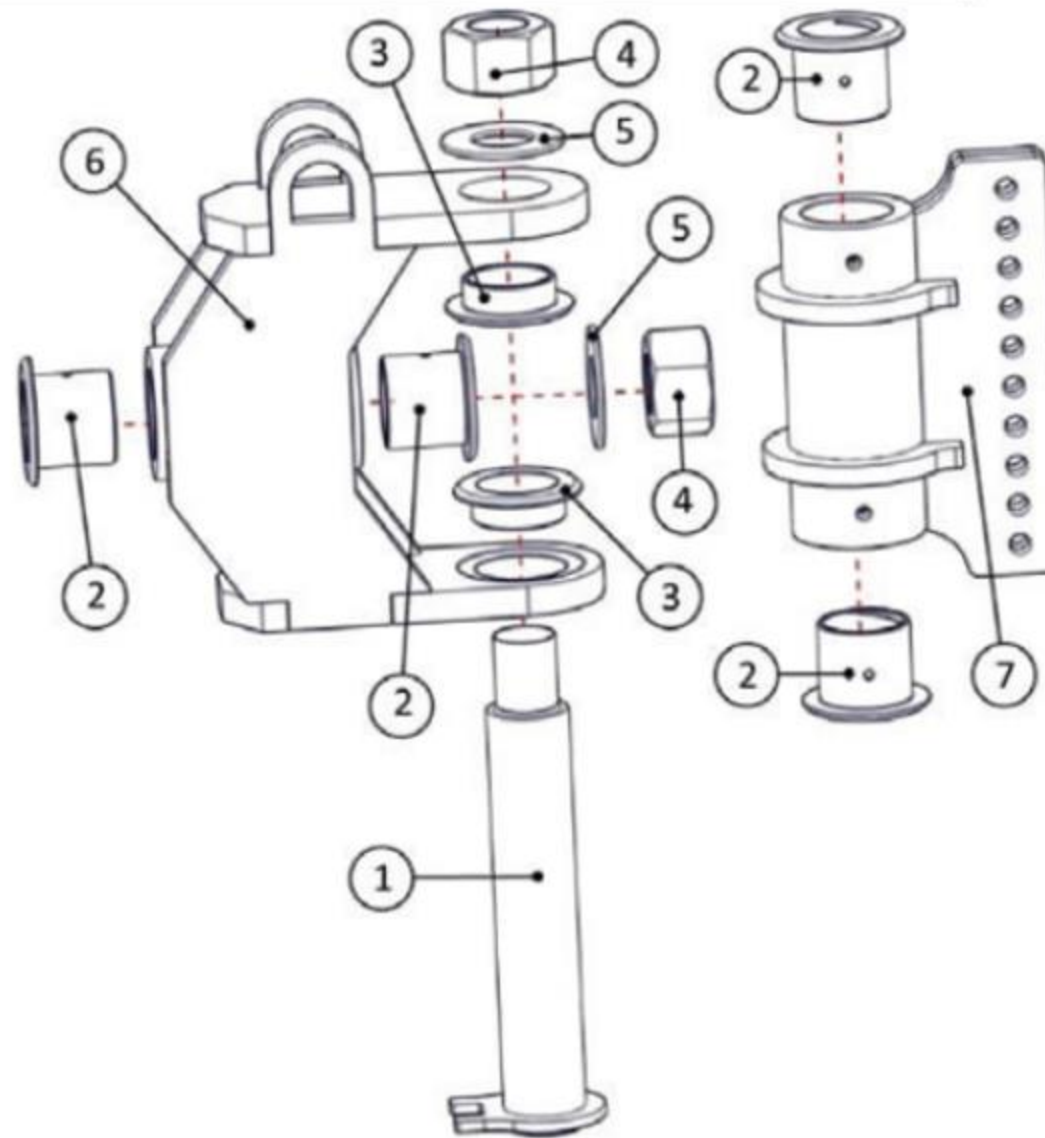
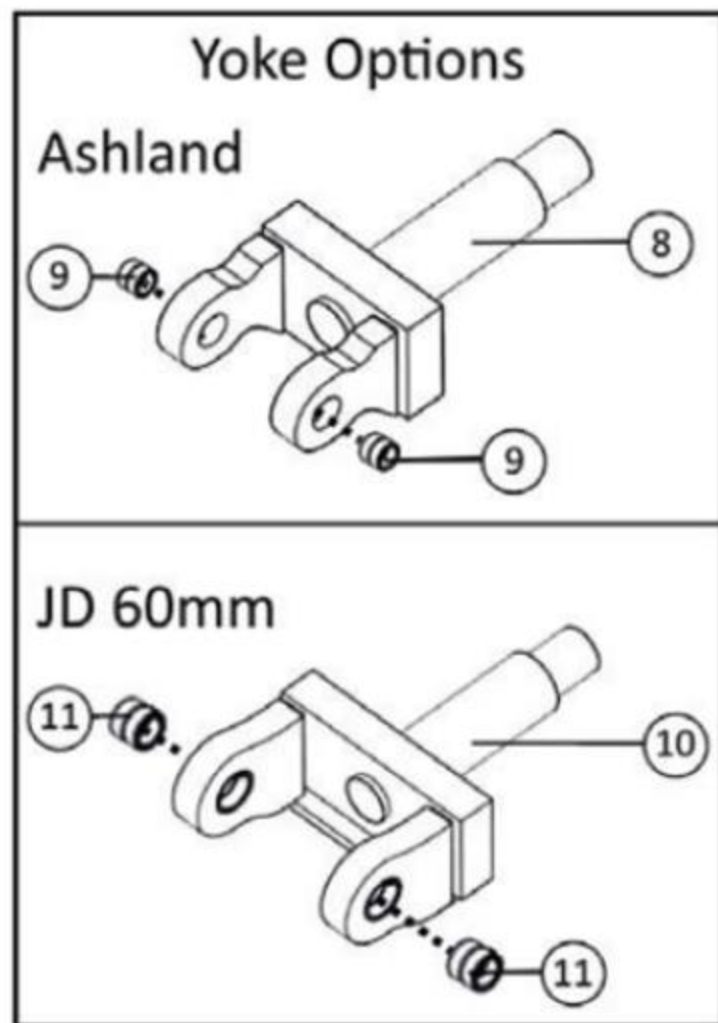
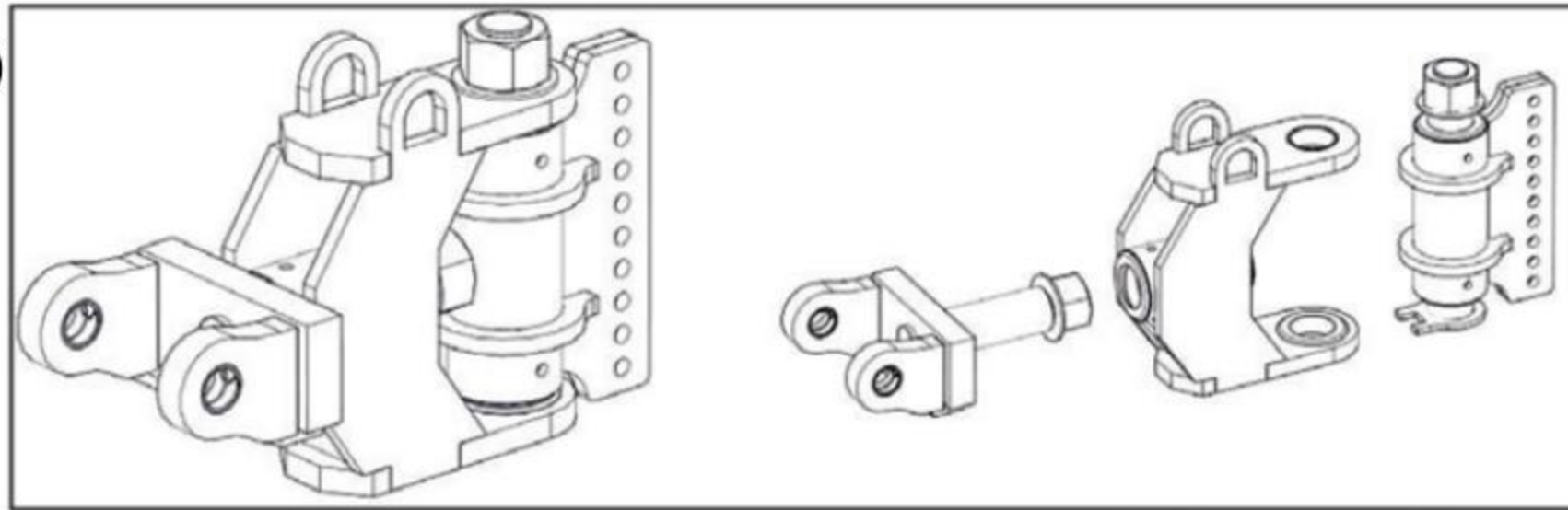

Item	Part Number	Description
1	600925	Pin: 4" Vertical
2	502086	Bushing: 4" ID, Long
3	502087	Bushing: 4" ID, Short
4	601026	Nut: 3" Clamping w/ 3/8"-16 x 2" SHCS
5	501937	Washer: 6" Steel
6	601085	Housing: Main Body w/ Welded Bushings
7	601084	Bracket: 10-Hole w/ Welded Bushings
8	600895	Yoke: 1-1/2" Swivel
	CNH 84268964	Pin Ass'y.: 1-1/2" Dia. w/ Nut & Cotter Pin
9	A123343	Bushing: Spring 1-1/2" ID
10	600901	Yoke: 60mm Swivel
11	400216	Bushing: Spring 60mm ID

# 601135 Ashland Hitch



**FIRST USED  
2017**

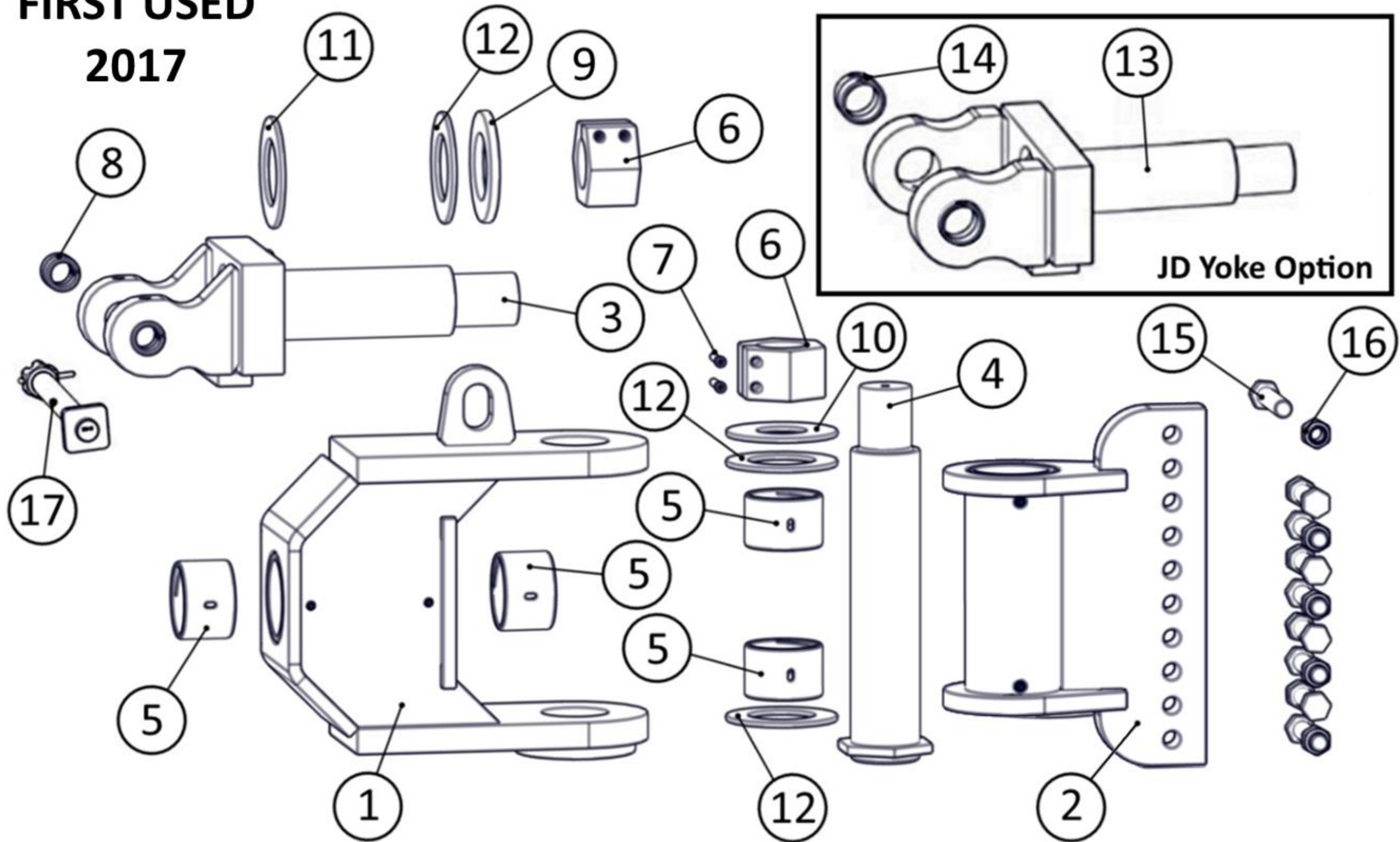

Item	Part Number	Description
Ashland Hitch	601135	Hitch Ass'y.: Includes Items 1 – 12 only
1	601139	Hitch: Housing
2	601138	Hitch: Vertical Bracket
3	601090	Yoke: Ashland Swivel
4	600925	Pin: Vertical, 4"
5	400312	Bushing: 4" ID x 3" Long
6	601026	Clamp: 3"-8 Nut w/ Cap Screws
7	AFB-00184	Cap Screw: 3/8"-16 x 2"
8	A123343	Bushing: Spring 1-1/2" x 2" w/ Grease Hole
9	501937	Ring: Steel, 4" ID x 8" OD
10	503468	Ring: Steel, 3" ID
11	400318	Washer: UHMW, 4" x 6-3/8"
12	400384	Washer: Nylon, 4" x 8"
13	601121	Yoke: JD Swivel
14	400216	Bushing: Spring 2-3/8" x 2-7/8" w/ Grease Hole
15	AFB-00021	HHCS: 1"-8 x 5-1/2" (10 Bolts Required)
16	AFN-00037	Nut: 1"-8 Top Lock
17	CNH 84268964	Pin Ass'y.: 1-1/2" Diameter w/ Nut & Cotter Pin

# 601440 HD Ag. Cat. 4 Swivel Hitch

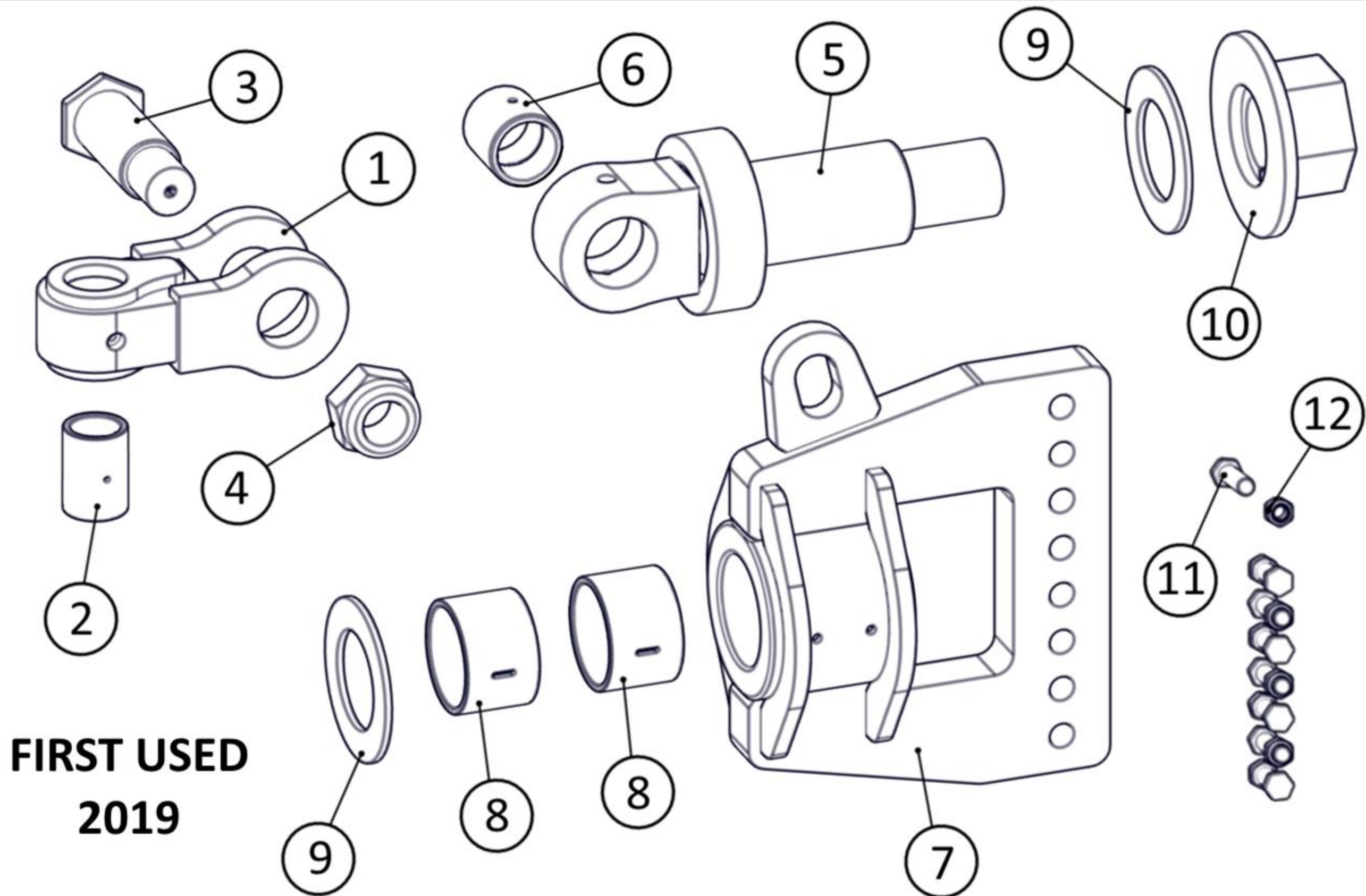

Item	Part Number	Description
HD Ag. Hitch	601440	Hitch Ass'y.: Includes Items 1 – 10 Only
1	601438	Yoke Ass'y.: Yoke w/ Bushing <b>(Item 2 Installed)</b>
2	400614	Bushing: 2" x 3-1/2" w/ Grease Hole
3	601441	Pin: Hex 2-1/2" x 7-1/2"
4	AFN-00033	Nut: 2"-12 Nylon Insert Lock Nut
5	601437	Swivel Ass'y.: 4" Swivel w/ Bushing <b>(Item 6 Installed)</b>
6	400613	Bushing: 2-1/2" x 3" w/ Grease Hole
7	601439	Housing: Body w/ Bushings <b>(2pc Item 8 Installed)</b>
8	400615	Bushing: 4" x 3" w/ Grease Slot
9	504610	Washer: Nylon, 4" x 6-1/2"
10	601482	Nut Ass'y.: 3-8" Flanged Clamp Nut
11	AFB-00021	HHCS: 1"-8 x 5-1/2" (8 Bolts Required)
12	AFN-00037	Nut: 1"-8 Top Lock

# 601135 Ashland Hitch



**FIRST USED  
2020**

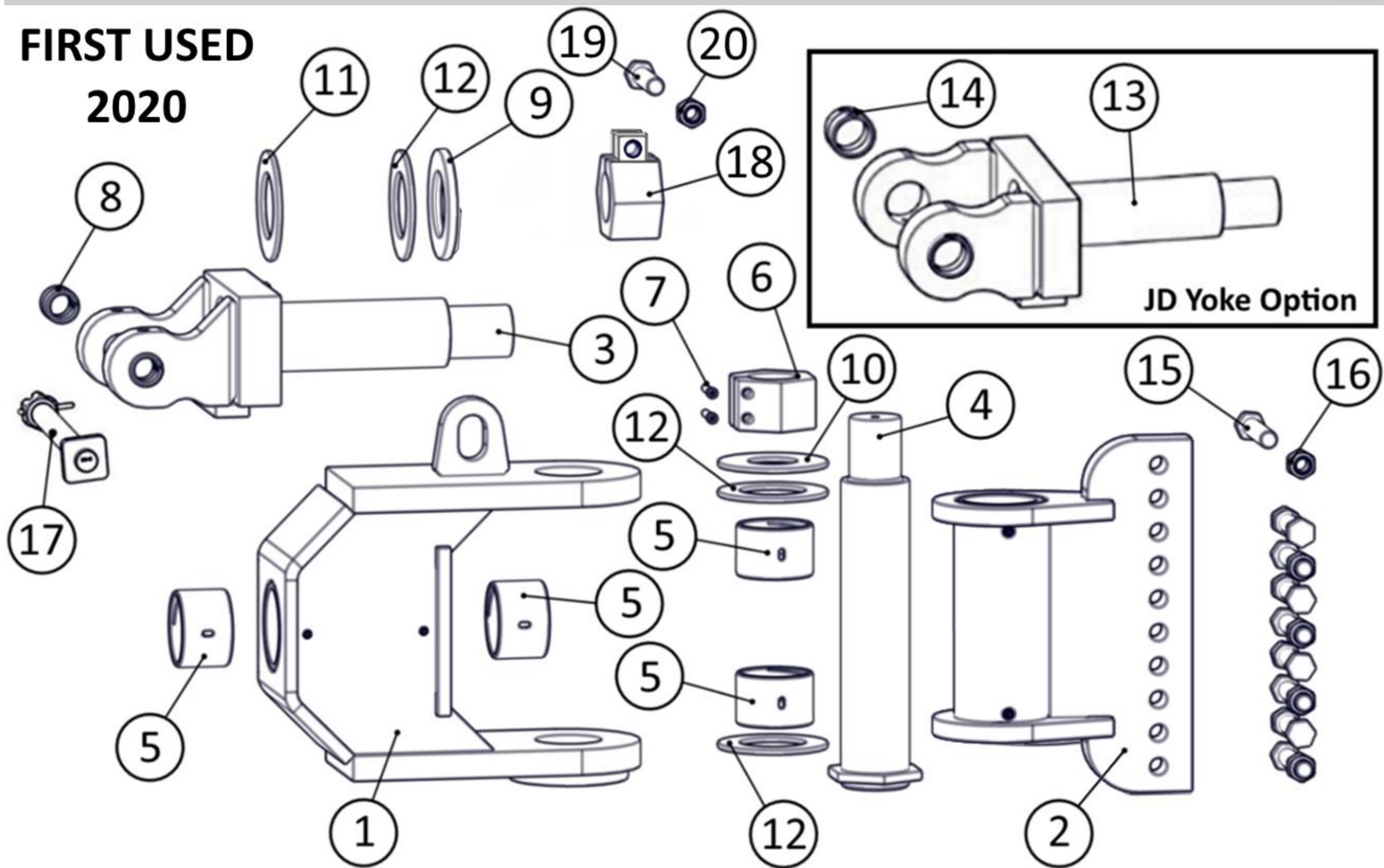

Item	Part Number	Description
Ashland Hitch	601135	Hitch Ass'y.: Includes Items 1 – 12 & 18 only
1	601139	Hitch: Housing
2	601138	Hitch: Vertical Bracket
3	601090	Yoke: Ashland Swivel
4	600925	Pin: Vertical, 4"
5	400312	Bushing: 4" ID x 3" Long
6	601026	Clamp: 3"-8 Nut w/ Cap Screws
7	AFB-00184	Cap Screw: 3/8"-16 x 2"
8	A123343	Bushing: Spring 1-1/2" x 2" w/ Grease Hole
9	601549	Ring: Steel, 3" ID x 8" OD w/ 4-1/8" ID Shoulder
10	503468	Ring: Steel, 3" ID
11	400318	Washer: UHMW, 4" x 6-3/8"
12	400384	Washer: Nylon, 4" x 8"
13	601121	Yoke: JD Swivel (requires 601392 Sleeve & 600609 Pin)
14	400216	Bushing: Spring 2-3/8" x 2-7/8" w/ Grease Hole
15	AFB-00021	HHCS: 1"-8 x 5-1/2"
16	AFN-00037	Nut: 1"-8 Top Lock
17	CNH 84268964	Pin Ass'y.: 1-1/2" Diameter w/ Nut & Cotter Pin
18	601550	Clamp: 3"-8 Eared Nut w/ HHCS & Nut
19	AFB-00086	HHCS: 1"-8 x 3-1/2"
20	AFN-00012	Nut: 1"-8

# 601689 Ashland Universal Hitch

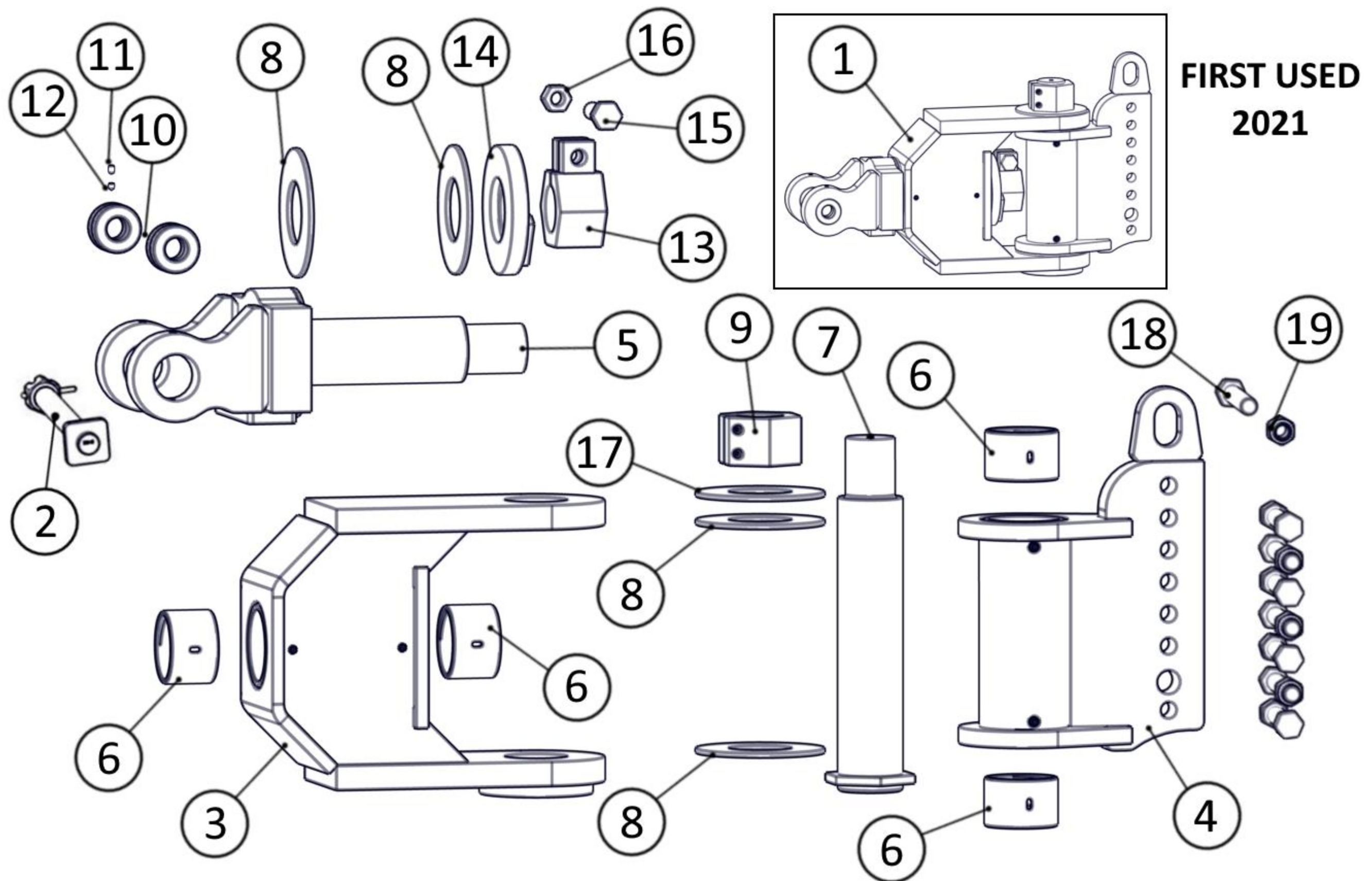

Item	Part Number	Description
1	601689	Hitch Ass'y.: Includes Items 3 – 17
2	CNH 84268964	Pin Ass'y.: 1-1/2" Diameter w/ Nut & Cotter Pin
3	601685	Housing: Main w/ Bushings <b>(2pc Item 6 Installed)</b>
4	601684	Bracket: Vertical w/ Bushings <b>(2pc Item 6 Installed)</b>
5	601713	Yoke: Swivel w/ Bushings <b>(2pc Item 10 Installed)</b>
6	400312	Bushing: 4" ID x 3" Long
7	600925	Pin: Vertical, 4"
8	400384	Washer: Nylon, 4" x 8"
9	601026	Clamp: 3"-8 Nut w/ 3/8"-16 x 2" Cap Screws
10	400773	Bushing: 1-1/2" ID x 3" OD w/ Grease Groove
11	405000122	Socket Set Screw: Flat 1/2"-13 x 3/4"
12	405000121	Socket Set Screw: Cone Point 1/2"-13 x 1/2"
13	601550	Clamp: 3"-8 Nut w/ HHCS & Nut <b>(Includes Item 15 &amp; 16)</b>
14	601549	Ring: Keeper, 3" ID x 8" OD w/ 4-1/8" ID Shoulder
15	AFB-00086	HHCS: 1"-8 x 3-1/2"
16	AFN-00012	Nut: 1"-8
17	503468	Ring: Steel, 3" ID
18	AFB-00021	HHCS: 1"-8 x 5-1/2" (8 Bolts Required)
19	AFN-00037	Nut: 1"-8 Top Lock

# 311100035-R2 Kit

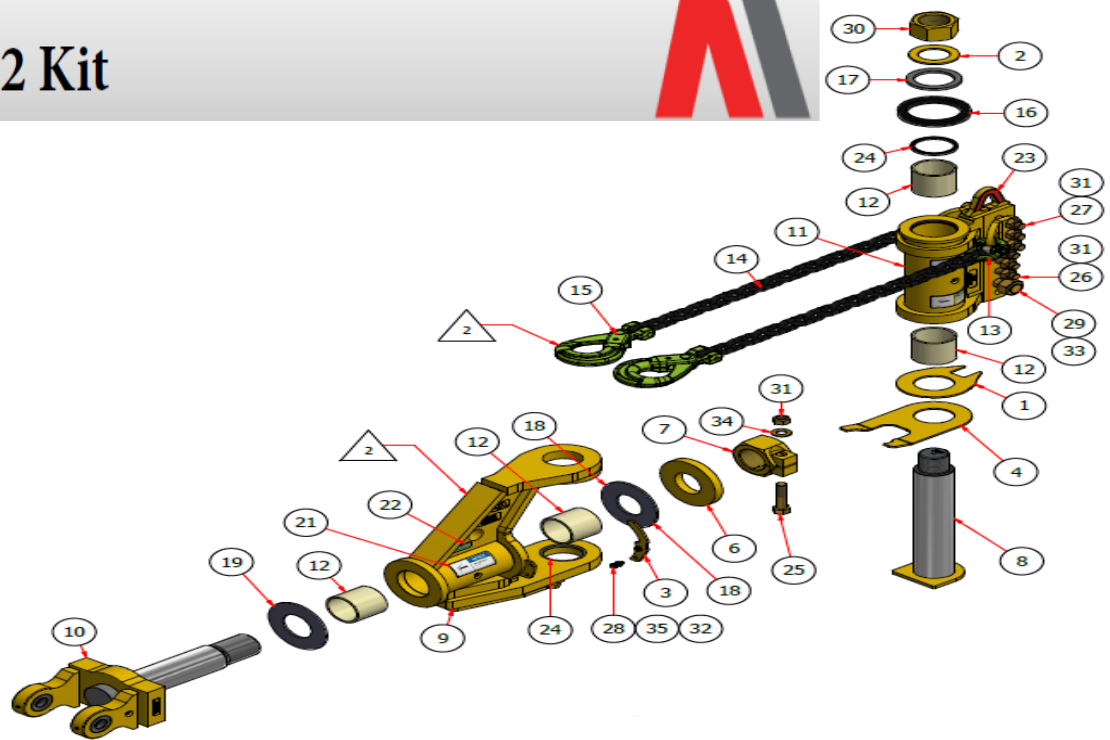

## PARTS LIST

ITEM	QTY	PART NUMBER	REV	DESCRIPTION
1	1	101000106_cm_K	1	Grease_Thrust_Washer_Vertical .pin
2	1	101001956_c_K-CY	0	Washer_knuckle_vert.pin
3	2	101009913_c_K-CY	0	Knuckle, Chain Keeper
4	1	101009914_cb_K-CY	0	Knuckle, Thrust Washer
5	2	101010052_cvb_H-CY	2	Knuckle_Safety Chain Ear
6	1	301000053_w_K-CY	0	Washer 3 1/2" Squeeze Nut
7	1	301000054_wms_K-CY	1	Thrust Nut (Knuckle)
8	1	301002676_w_K-CY	0	Pin Vertical_4" (PG shaft induction hardend)
9	1	301002711_wm_K-CY	8	Knuckle, Sub-weldment
10	1	301003258_w_K-CY	3	Yoke, Ashland UNC
11	1	301004503_wm-CY	1	Vertical Bushing Weldment
12	4	404000009	0	Comp Bushing 4.00" ID x 4.50" OD x 4.00"
13	2	405500014	0	5/8" Grade 100 Coupling Link
14	2	405500032	0	Chain Grade 100 5/8" 21 Links
15	2	405500043	0	5/8" Grade 100 Clevis Self-Locking Hook
16	1	409000021	0	Seal .75"-7.25" OD-5.50" ID
17	1	409000022	0	Seal .375"- 5.50" OD- 4.06" ID
18	1	409000034	0	Thrust Washer .25"- 7.75" OD - 3.50" ID
19	1	409000100	1	Thrust Washer 0.250" x 8.00" OD x 4.063" ID
20	1	411000041	2	Decal - Caution Lift Point
21	2	411000046	2	Decal - Notice Grease Daily
22	1	411000102	1	Decal - Safety Tie Down
23	2	411000206	0	Decal - Lift Hook Highlight, Knuckle
24	2	422000003	0	Seal 4" Pin
25	1	BLT8C_1x4_1-2	0	Bolt Gr. 8 UNC 1" x 4-1/2"
26	3	BLT8C_1x5_1-2	0	Bolt Gr. 8 UNC 1" x 5-1/2"
27	3	BLT8C_1x7	0	Bolt Gr. 8 UNC 1" x 7"
28	4	BLT8C_3-8x1_1-4	0	Bolt Gr. 8 UNC 3/8" x 1-1/4"
29	1	BLT8F_1_1-2x5_1-2	0	Bolt Gr. 8 UNF 1-1/2" x 5-1/2"
30	1	NUT2C_3_m_N-CY	0	Nut Gr. 2 UNC 3" Machined and Painted
31	7	NUT8C_1_STL	0	Nut Gr. 8 UNC 1" Stover Lock
32	4	NUT8C_3-8_STL	0	Nut Gr. 8 UNC 3/8" Stover Lock
33	1	NUT8F_1_1-2	0	Nut Gr. 8 UNF 1-1/2"
34	1	WSH8_1_STR	0	Washer Gr. 8 - 1" Structural
35	8	WSH8_3-8_STR	0	Washer Gr. 8 - 3/8" Structural