

# **ASHLAND** INDUSTRIES

## Parts Manual 3250SS

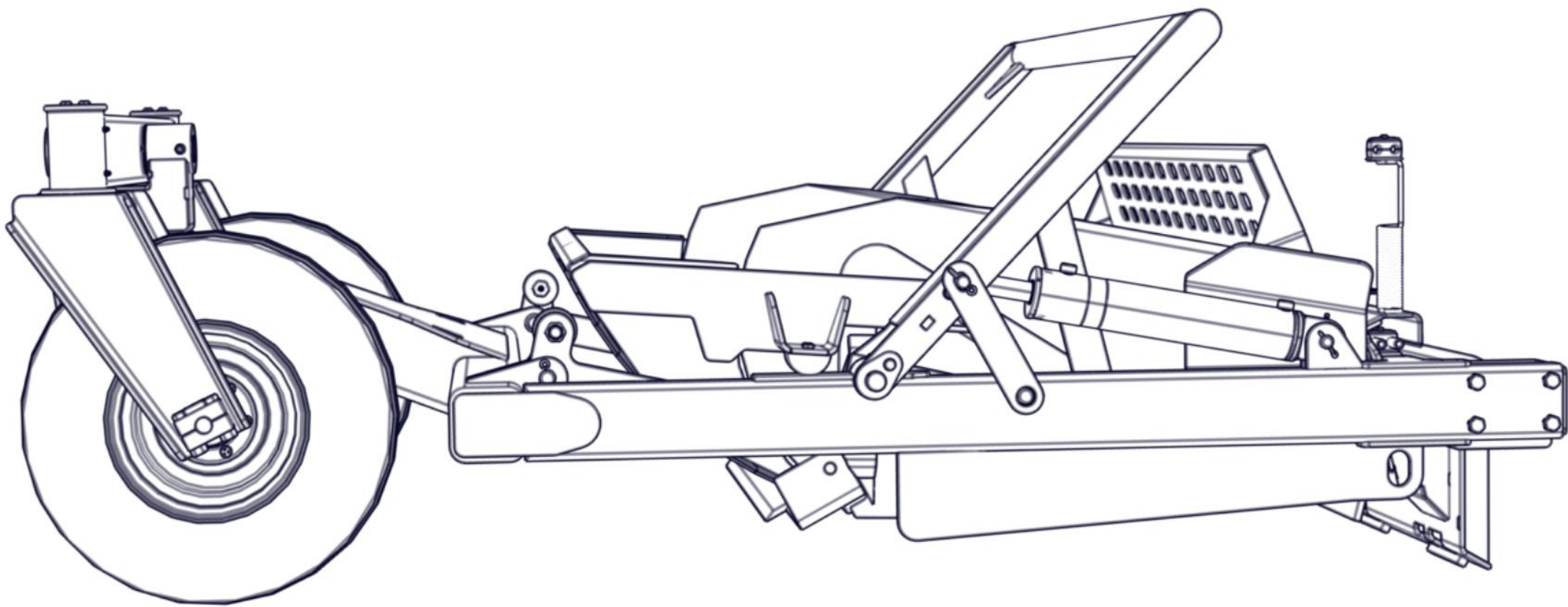

WG-3250-002

2-23

26931+

*Address*

1115 Rail Drive  
PO BOX 717  
Ashland, WI USA 54806



*Toll Free*

(877) 634-4622

*Business*

(715) 682-4622

*Fax*

(715) 682-9717

*Website*

[www.ashlandind.com](http://www.ashlandind.com)

# Table of Contents



Introduction	3
Scraper Specifications	4
Assembly	5
Frame	6
Rock Shaft	7
Oscillating Beam	8
Wheel Assembly	9
Apron	10
Bowl	11
Actuating Frame	12
Lift Cylinder	13
Hydraulic Lines & Locks	14
Hydraulic Tube Clamps	15
Decals	16
Operation & Maintenance	17
Safety Guidelines	20
Tire Inflation & Torque Chart	21
Tire Service	22
Hub Service	23
Troubleshooting	24
Warranty Statement	25



Thank you for choosing an Ashland scraper for your earthmoving needs. Years of research, testing, and successful application have been spent to ensure quality and maximum performance for our customers.

## Quality Policy

It is our mission to exceed our customers' expectations in quality, delivery, and cost through continuous improvement and customer interaction.

Please read and understand this manual before attempting to attach or operate this scraper. This manual should always remain with the machine. Be sure and fill out and send in the owner's registration form at the beginning of this manual, or you may fill out the form on-line by going to [ashlandind.com](http://ashlandind.com) and click on "Owner Registration" in the Parts section drop-down. If you have questions, please feel free to call or email us. You can visit us on-line at [www.ashlandind.com](http://www.ashlandind.com).

Ashland Industries hours of operation are 8:00 a.m. to 5:00 p.m. CST. We can be reached toll free at: 877-634-4622.

## Scraper ID Number

You can find the serial number plate for **most** machines on the right side of the scraper in the top corner of the bowl. CS models will have plates on the front horse-head or front section. The letter and numbers stamped identify the serial number, model number, and capacity of the scraper. Please record this serial number for use in ordering parts, warranty issues, and to track your equipment if it is ever stolen.



## Important

Parts must be ordered through your local authorized ASHLAND dealer. Be sure to state MODEL and SERIAL NUMBER of your machine. Ashland Industries Weldable replacement parts are also available to rebuild, modify, or update your scraper to current factory specifications.

# Scraper Specifications



<b>Capacity, Struck</b>	2.6 Cubic Yards
<b>Capacity, Heaped</b>	3.25 Cubic Yards
<b>Overall Dimensions:</b> Length Width Height	128 Inches 101 Inches 48 Inches
<b>Apron Clearance</b>	15 Inches
<b>Weight: Empty</b>	3,966 Pounds
<b>Cutting Width</b>	82 Inches
<b>Depth of Cut</b>	5-3/8 Inches
<b>Dump Angle</b>	70 Degrees
<b>Blade: 4 Piece</b> Center Corner Rear Leveling	1/2 x 8 x 50 Inches 1/2 x 6 x 16 Inches 1/2 x 6 x 88 Inches
<b>Cylinders:</b>  Lift	Two (3-1/2 x 16 Inches)
<b>Horsepower Requirements:</b> Single (Skid Loader)	100 - 225

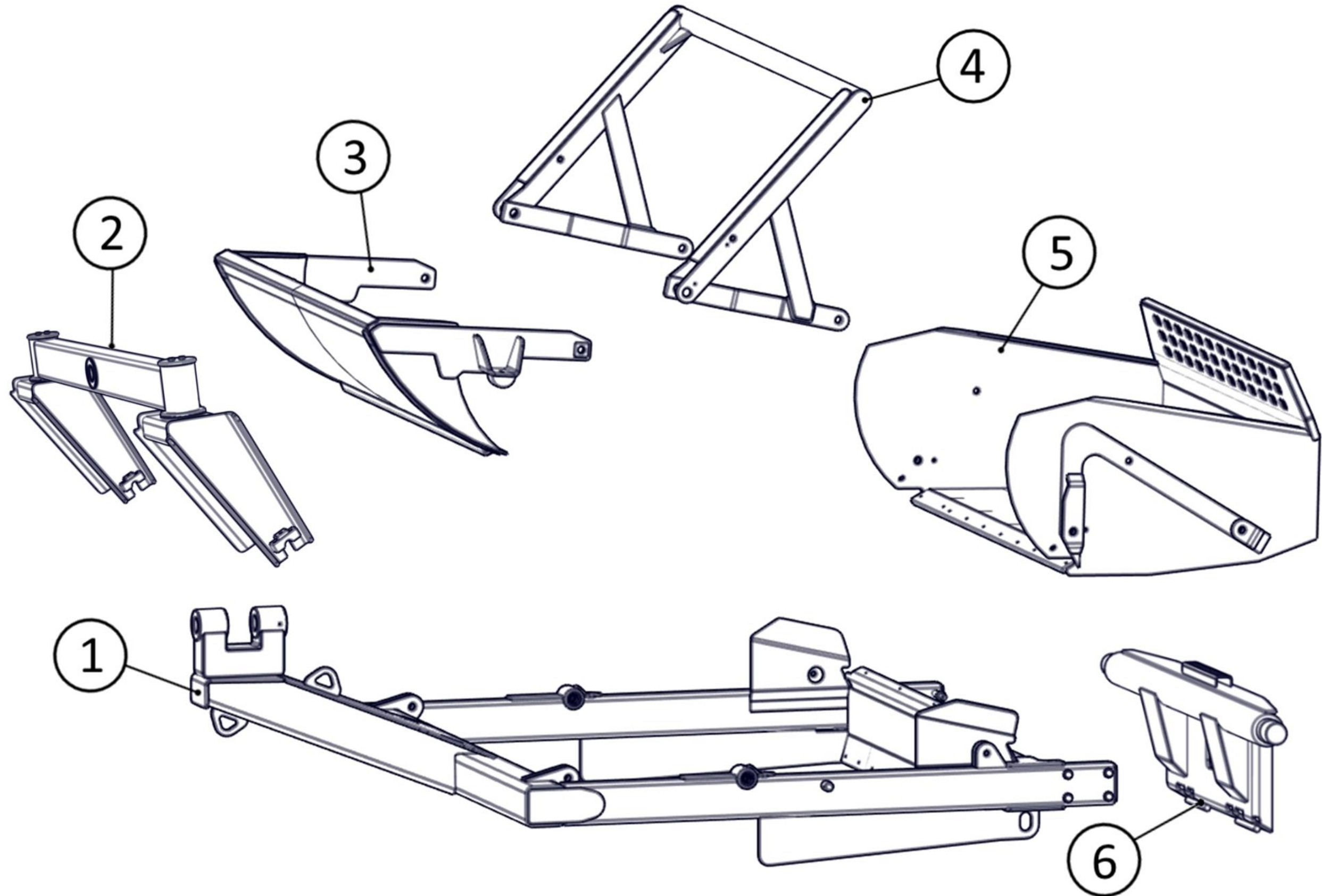

Item	Part Number	Description
1	601530	Frame
2	601915	Oscillating Beam
3	703029	Apron
4	601538	Actuating Frame
5	601539	Bowl
6	601537	Rock Shaft

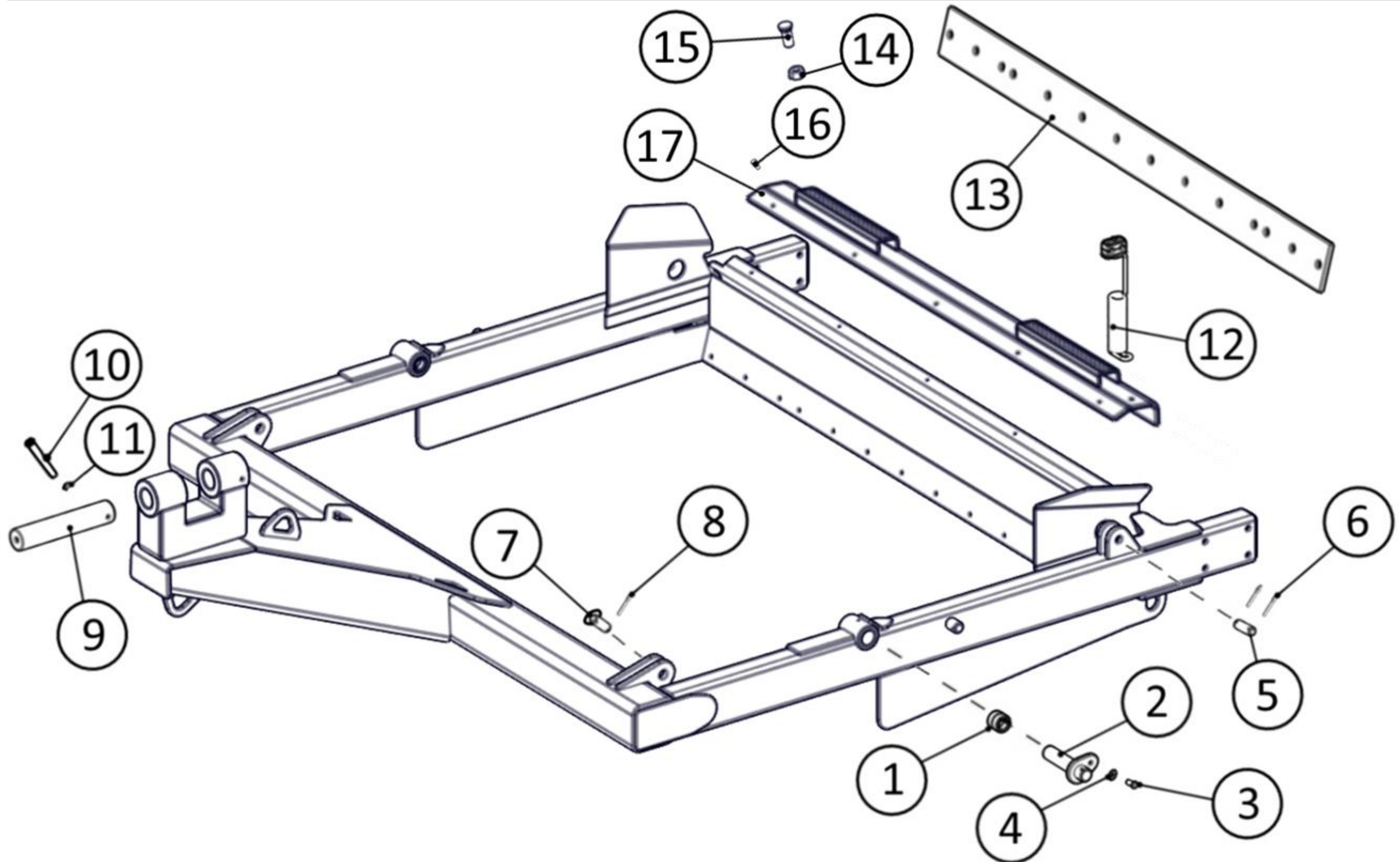

Item	Part Number	Description
1	A123343	Bushing: Spring 1-1/2" x 2" w/ Grease Hole
2	A2502A	Pin: 1-1/2" x 7-5/8" w/ Tab Head
3	AFB-00143	HHCS: 1/2"-13 x 1"
4	AFW-00030	Washer: 1/2" Split Lock
5	A2508	Pin: 1" x 3-1/4" w/ 2 Holes
6	AFP-00002	Pin: 3/16" x 2" Cotter
7	A3310	Pin: 1-1/4" x 3-1/4" w/Round Head
8	AFP-00010	Pin: 1/4" x 2" Cotter
9	A123469-05	Pin: 2-1/2" x 13-1/4" Caster Beam Pivot
10	AFB-00089	HHCS: 1/2"-13 x 5-1/2"
11	AFN-00011	Nut: 1/2"-13
12	400351	Hose Saver: Upper Spring Assembly
13	503616	Blade: Leveling (14 Bolts Required)
14	AFN-00011	Nut: 1/2"-13
15	PB5P-NC-050-0175	Bolt: Flat Head Plow 1/2"-13 x 1-3/4"
16	AFB-00128	Bolt: 3/8"-16 x 1" Serrated Flanged
17	601688	Guard: Dirt Shield w/ Step

# Rock Shaft

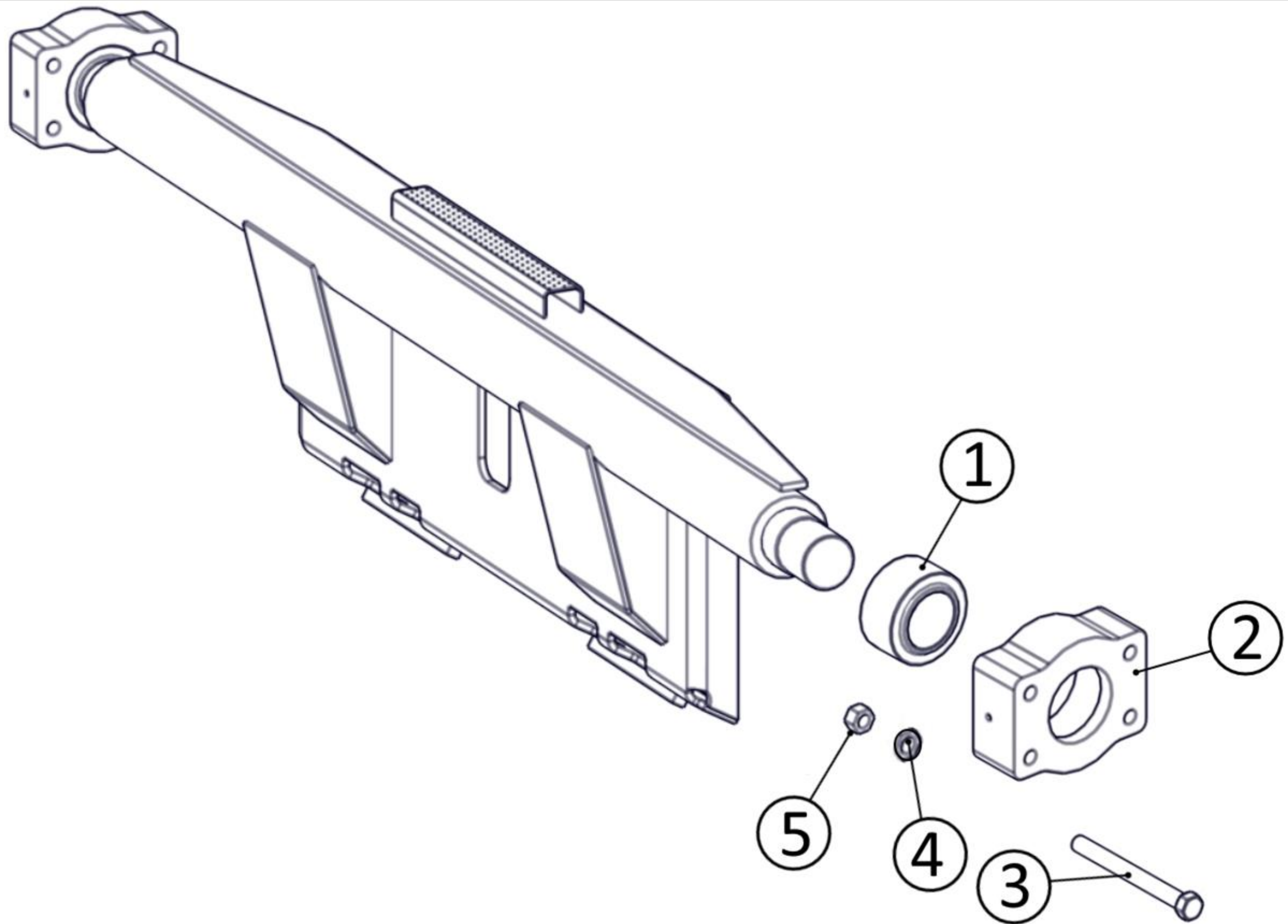

Item	Part Number	Description
1	A125212	Bushing: 3" ID Spherical
2	A123471-03	Mount: Bushing Rock Shaft
3	AFB-00099	HHCS: 3/4"-10 x 7"
4	AFW-00002	Washer: 3/4" Split Lock
5	AFN-00006	Nut: 3/4"-10

# Oscillating Beam

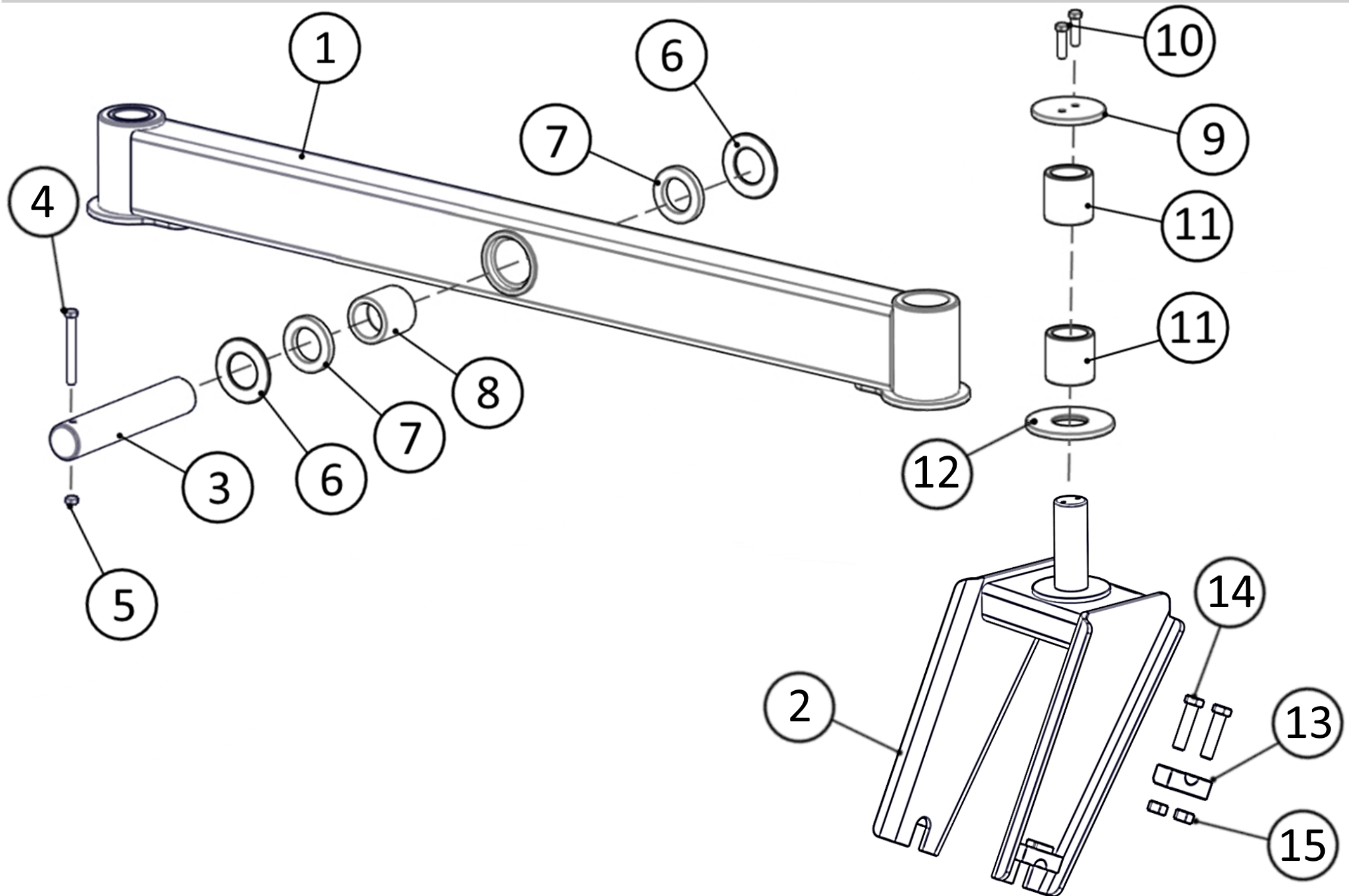

Item	Part Number	Description
1	601345	Beam Ass'y: Oscillating Crossover Caster
2	601913	Fork Ass'y: Caster w/ Axle Clamp
3	A123469-05	Pin: 2-1/2" x 13-1/4" Caster Beam Pivot
4	AFB-00089	HHCS: 1/2"-13 x 5-1/2"
5	AFN-00011	Nut: 1/2"-13
6	A125209	Bushing: 2-5/8" x 4-1/2" Thrust
7	A4512	Seal: 2-1/2" ID Grease
8	A125200	Bushing: 2-1/2" ID Pivot
9	503938	Cap: Vertical Pivot
10	AFB-00144	HHCS: 1/2"-13 x 2"
11	123469-04	Bushing: 2-1/2" ID Pivot w/ Grease Hole
12	504266	Spacer: 2-1/2" ID Steel
13	504941	Block: 1-3/8" ID Axle Mount
14	AFB-00228	HHCS: 3/4"-10 x 3-3/4"
15	AFN-00062	Nut: 3/4"-10 Top Lock



# Wheel Assembly

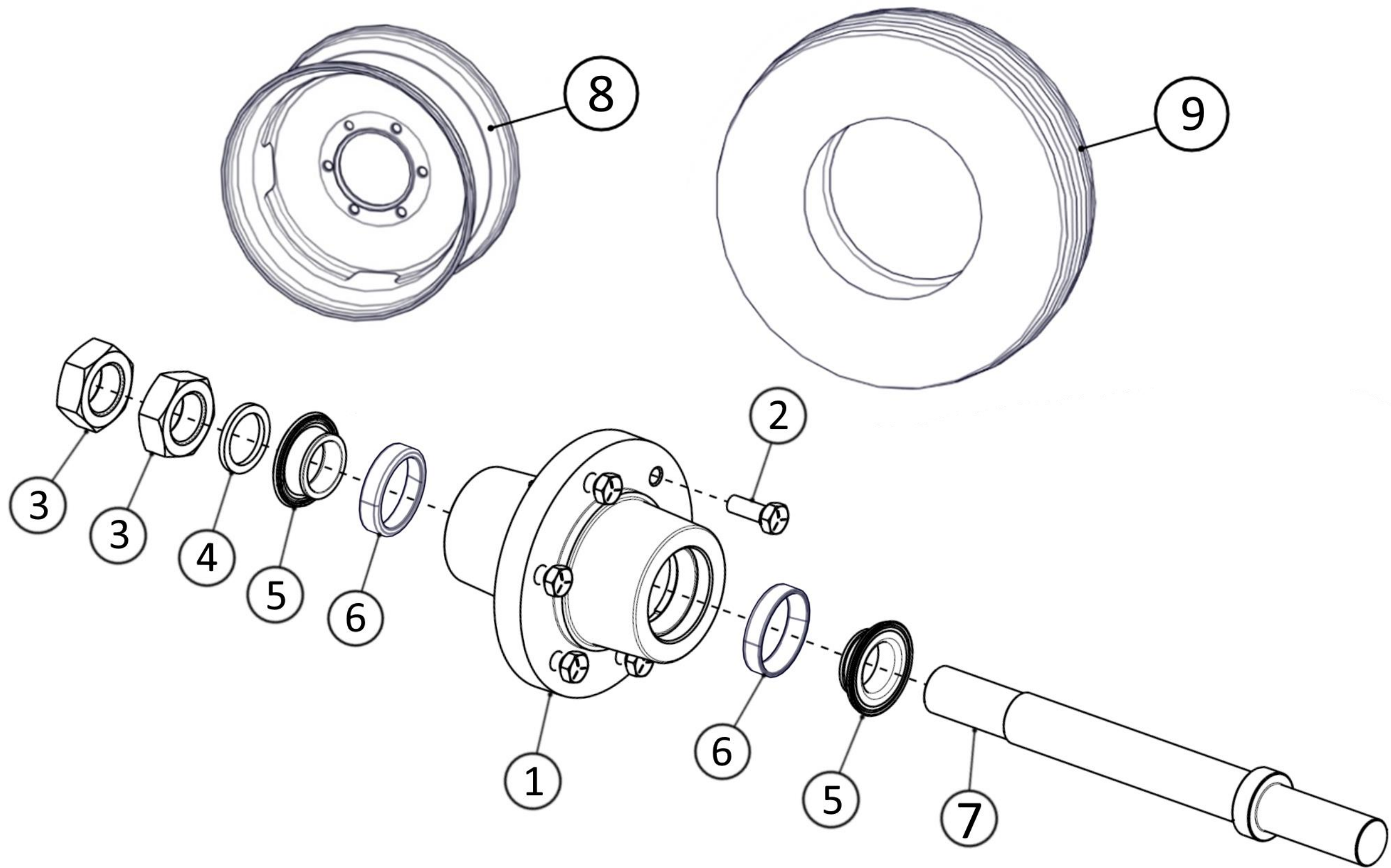

Item	Part Number	Description
1	400900	Hub: Cast 6-Hole w/ Pressed Cups 400903
2	A2236	Bolt: Conical Wheel 1/2"-20 x 1-1/4"
3	AFN-00082	Nut: 1-1/2"-12 Jam
4	400901	Spacer: 1-1/2" ID x 2" OD Steel
5	400902	Bearing: Cone w/ Integrated Grease Seal
6	400903	Bearing: Cup
7	400904	Axle: Stepped 1-1/2" Dia. x 15-3/4" Long Pass-Thru
8	A3319A	Wheel: 15" x 8" 6-Hole
9	ATI-00002	Tire: 11L - 15

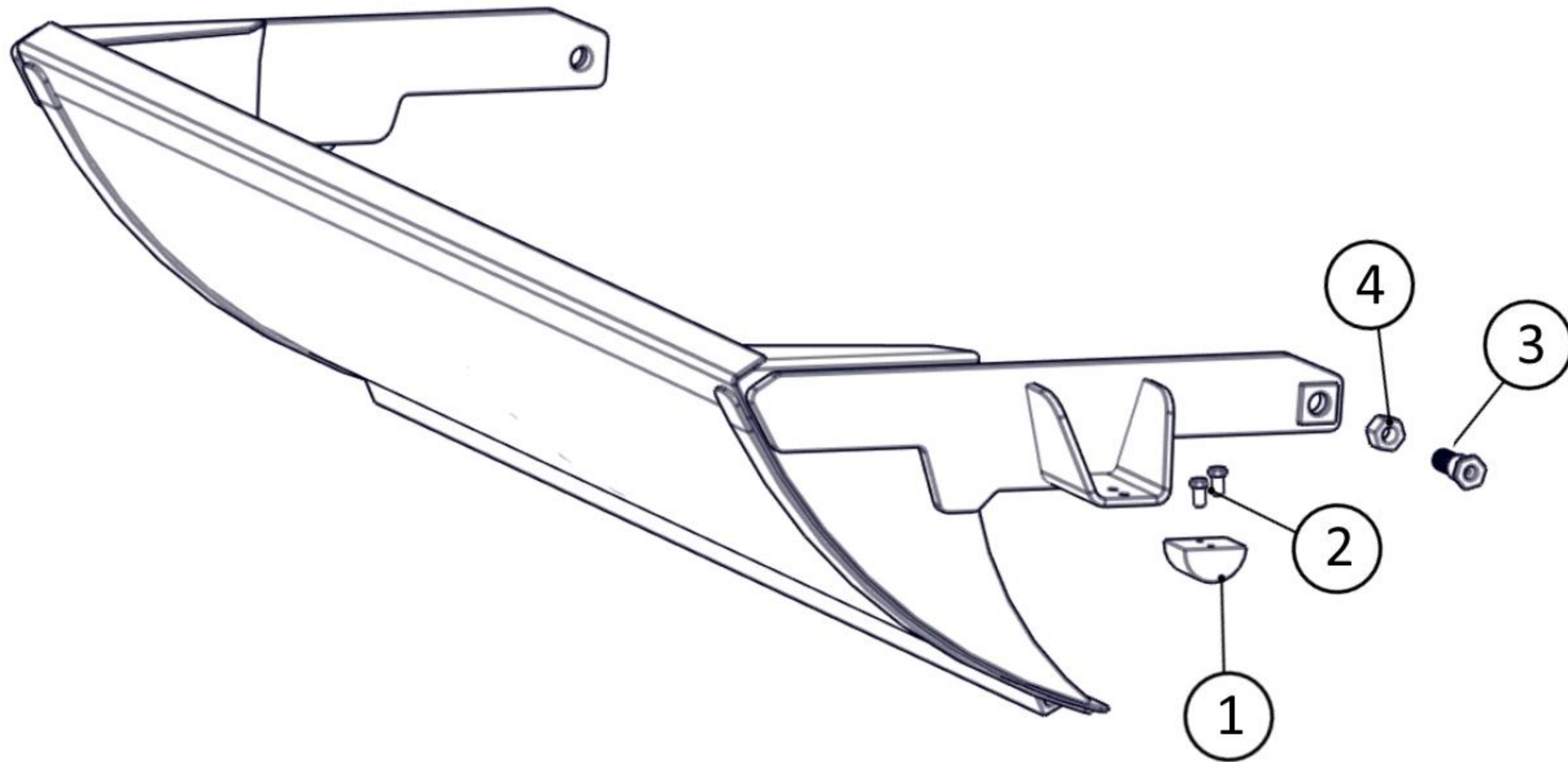

Item	Part Number	Description
1	400688	Pad: 3-1/2" x 2-1/4" Semicircular Slide
2	AFB-00143	HHCS: 1/2"-13 x 1"
3	A30020	Pin: 1"-14 x 1-1/8" w/ Shoulder
4	AFN-00001	Nut: 1"-14 Top Lock

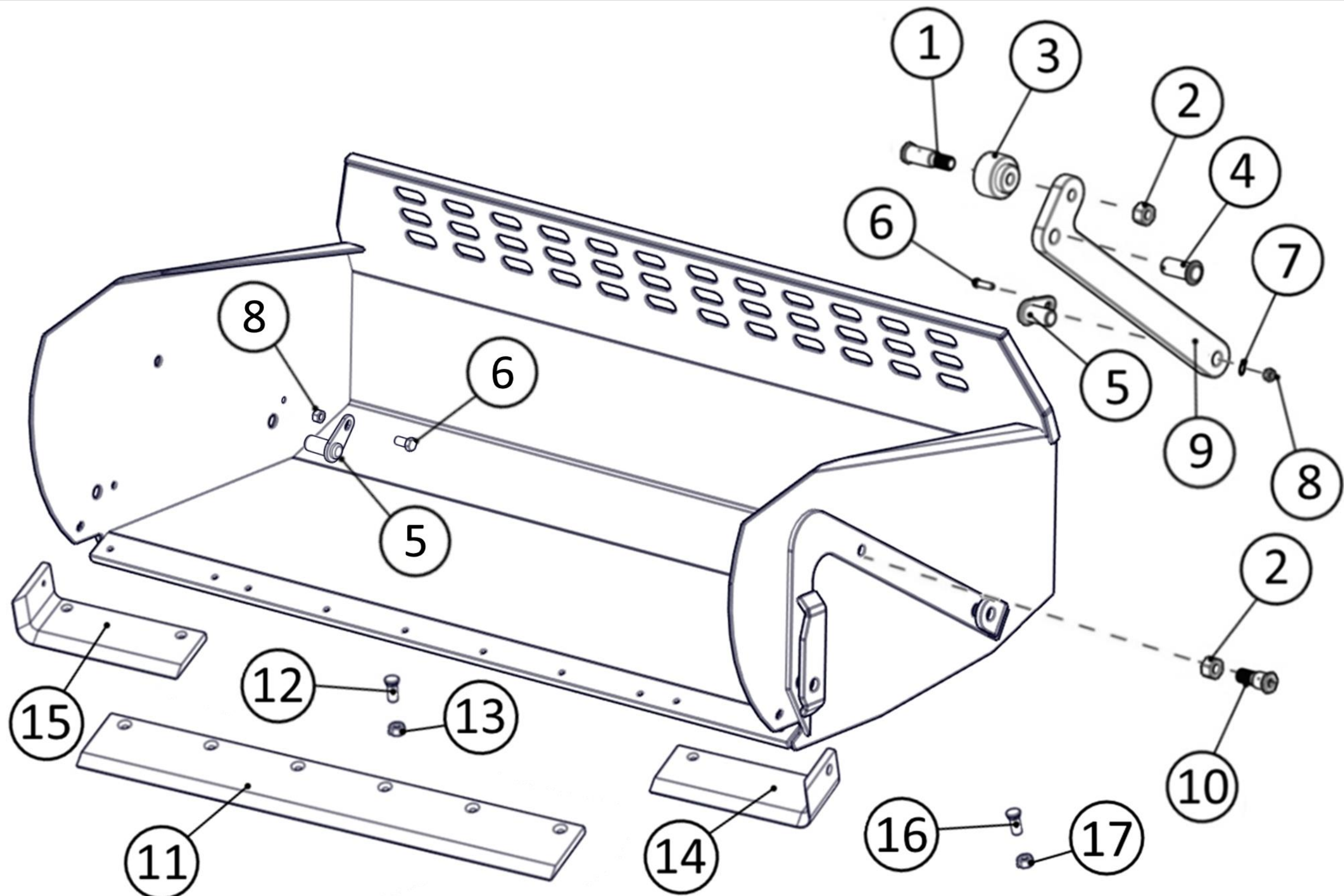

Item	Part Number	Description
1	A30003	Pin: 1"-14 x 2-1/2" w/ Shoulder
2	AFN-00001	Nut: 1"-14 Top Lock
3	A30002	Roller: 3-1/2" OD
4	A3310	Pin: 1-1/4" x 3-1/4" w/Round Head
5	600966	Pin: 1-1/4" x 2-9/16" w/Tab Head
6	AFB-00145	HHCS: 5/8"-11 x 1-1/4"
7	AFW-00031	Washer: 5/8" Split Lock
8	AFN-00050	Nut: 5/8"-11
9	A012165	Arm: Actuating Left & Right
10	A30020	Pin: 1"-14 x 1-1/8" w/ Shoulder
11	A45010	Blade: Center 1/2" x 8" x 50" Straight (6 Bolts Required)
Optional	A45010-6	Blade: Center 1/2" x 6" x 50", Finishing (6 Bolts Required)
12	PB8P-NC-063-0200	Bolt: Plow 5/8"-11 x 2" (Center Blade)
13	AFN-00050	Nut: 5/8"-11 (Center Blade)
14	A2222	Blade: Corner 1/2" x 6" Formed Left (3 Bolts Required)
15	A2225	Blade: Corner 1/2" x 6" Formed Right (3 Bolts Required)
16	PB5P-NC-050-0175	Bolt: Plow 1/2"-13 x 1-3/4" (Corner Blades)
17	AFN-00015	Nut: 1/2"-13 (Corner Blades)

# Actuating Frame

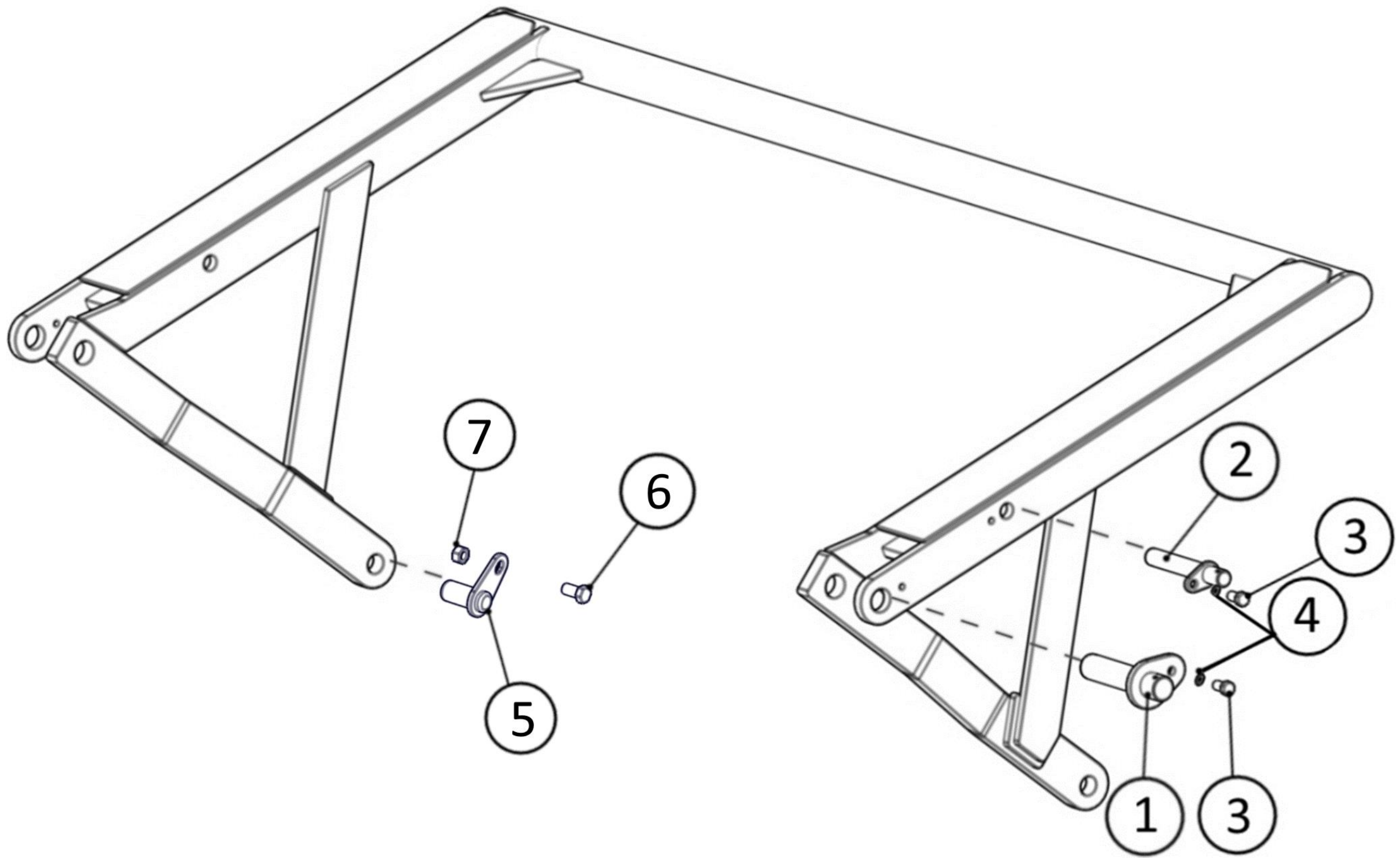

Item	Part Number	Description
1	A2502A	Pin: 1-1/2" x 7-5/8" w/ Tab Head
2	A3318A	Pin: 1" x 7-9/16" w/ Tab Head
3	AFB-00143	HHCS: 1/2"-13 x 1"
4	AFW-00030	Washer: 1/2" Split Lock
5	600966	Pin: 1-1/4" x 2-9/16" w/Tab Head
6	AFB-00145	HHCS: 5/8"-11 x 1-1/4"
7	AFN-00050	Nut: 5/8"-11

# Lift Cylinder - 400279

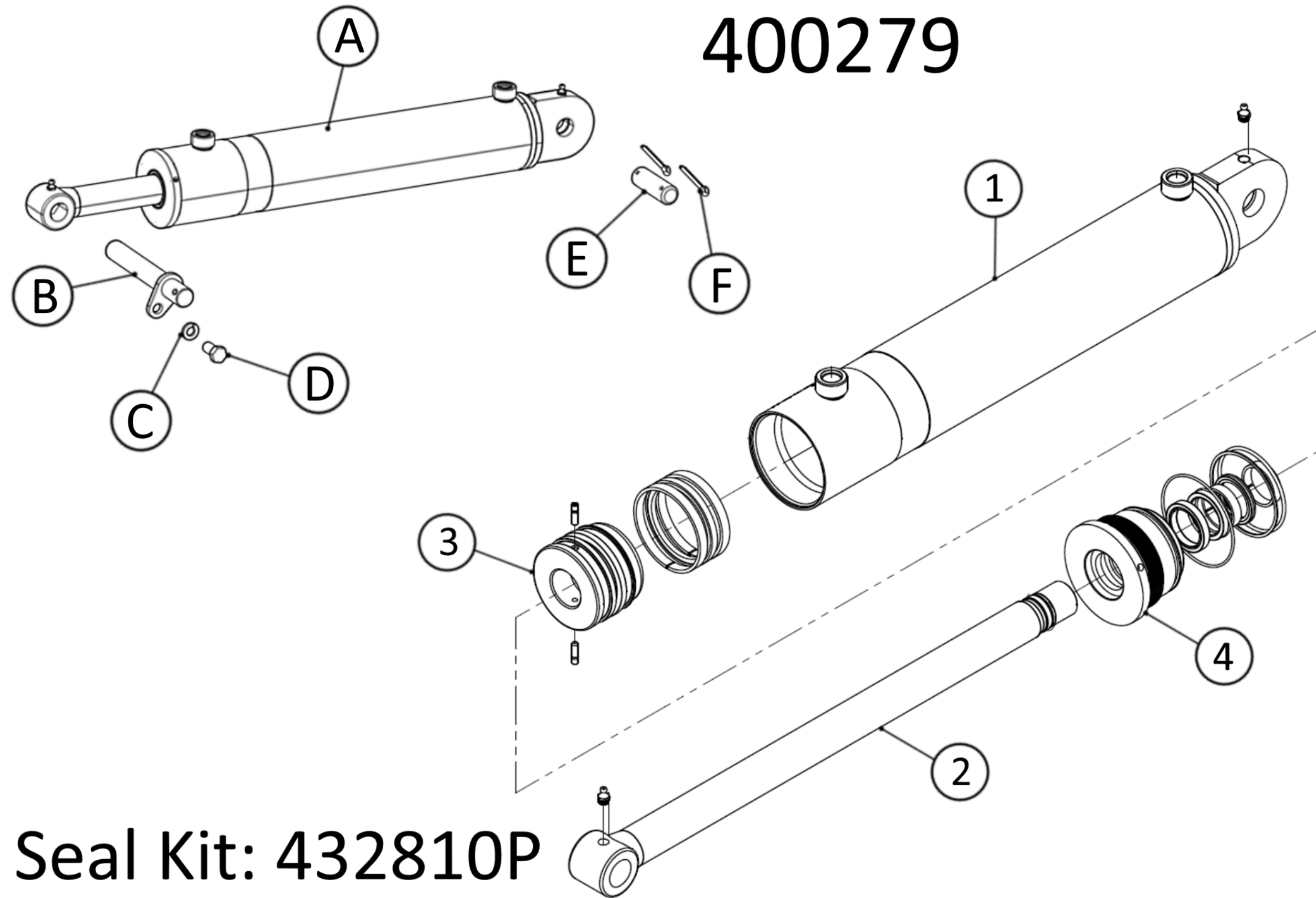

Item	Part Number	Description
A	400279	Cylinder: 3-1/2" x 16"
B	A3318A	Pin: 1" x 7-9/16" w/ Tab Head
C	AFW-00030	Washer: 1/2" Split Lock
D	AFB-00143	HHCS: 1/2"-13 x 1"
E	A2508	Pin: 1" x 3-1/4" w/ 2 Holes
F	AFP-00002	Pin: 3/16" x 2" Cotter
1	202436P	Barrel: for 3-1/2" x 16" Cylinder
2	302006P	Rod: 1-1/2"
3	400935P	Piston: Ass'y. 3-1/2" x 1-3/8"
4	500772P	Head: Ass'y. 3-1/2" x 1-1/2"
Seal Kit	432810P	Kit: Seal for 400279

# Hydraulic Lines & Locks

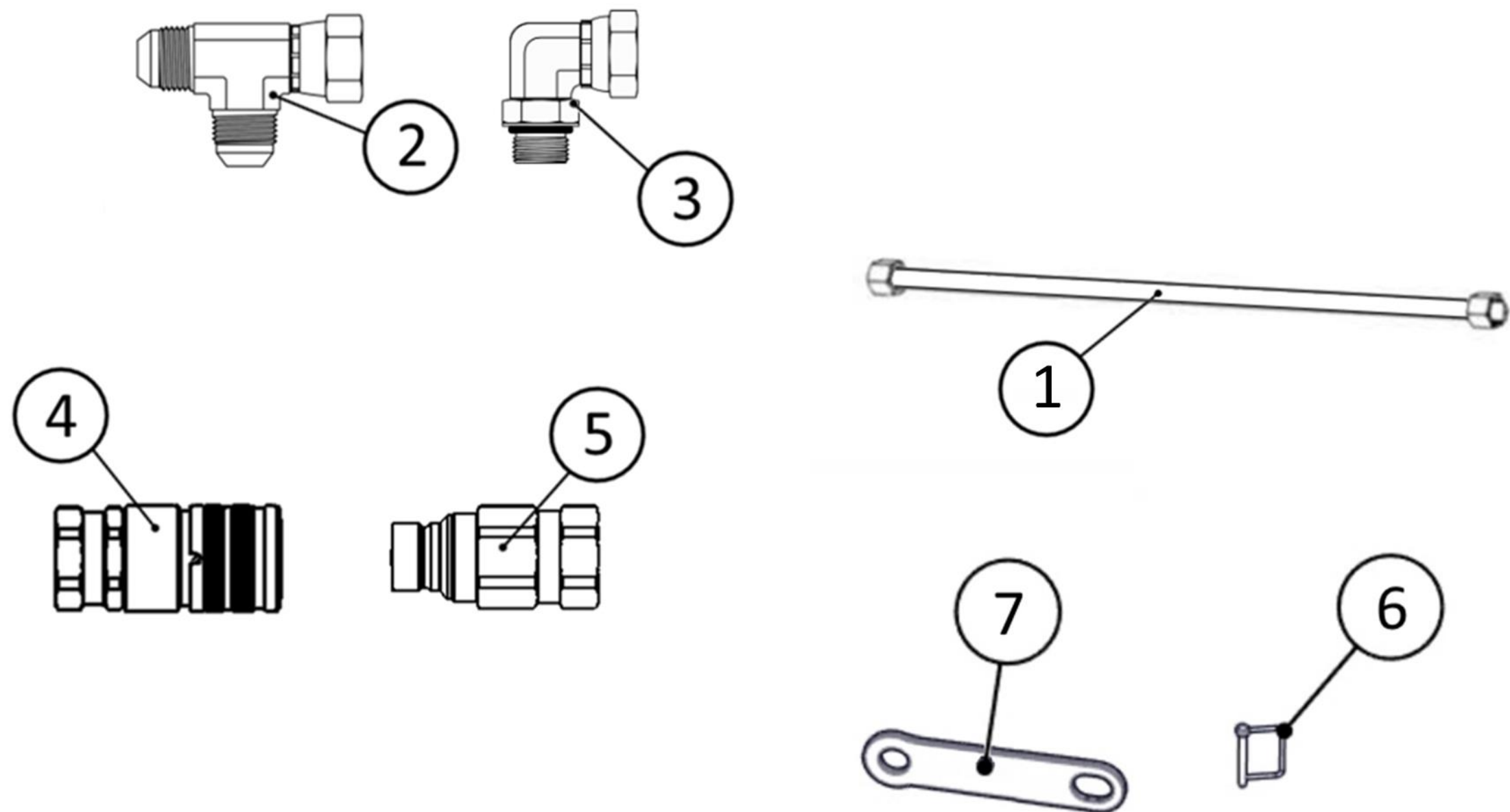

Item	Part Number	Description
1	400750	Tube Ass'y: 3/4" x 77-1/2" JIC
2	AHA-00049	Adapter: Tee 3/4" Male JIC x 3/4" Male JIC x 3/4" Female JIC
3	AHA-00086	Adapter: 90 Deg. Swivel 1/2" Male ORB x 1/2" Female NPT
4	A125207	Coupler: Female Flat Face, Skid Steer
5	A125208	Coupler: Male Flat Face, Skid Steer
6	A125006	Pin: 1/4" x 2-1/2" Wire Snapper
7	502896	Lock: Transport
Hose Kit	400749	Kit: Hose 3250SS Complete (Hoses below w/ Items 4 & 5)
	400751	Hose Ass'y.: Left & Right Cylinder Rod Port, 1/2" x 30"
	400752	Hose Ass'y.: Left & Right Cylinder Base Port, 1/2" x 14"
	400753	Hose Ass'y.: Connecting Feed, 1/2" x 85"

# Hydraulic Tube Clamps



**Each Tube Clamp is sold as a complete assembly.**

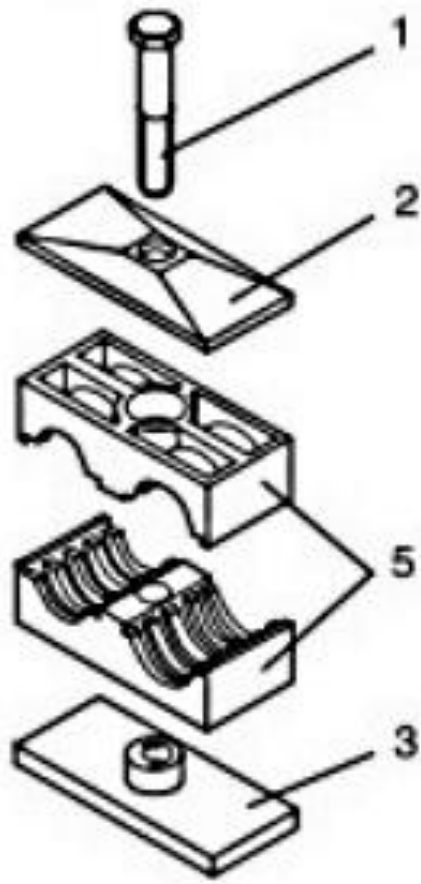

Twin Clamp with  
Weld Plate

Assembly number:  
**AHL-00002**

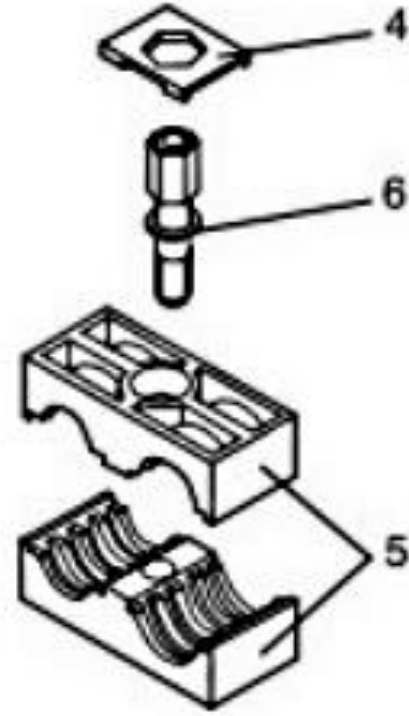

Twin Clamp  
Stacking Module

Assembly number:  
**AHL-00022**

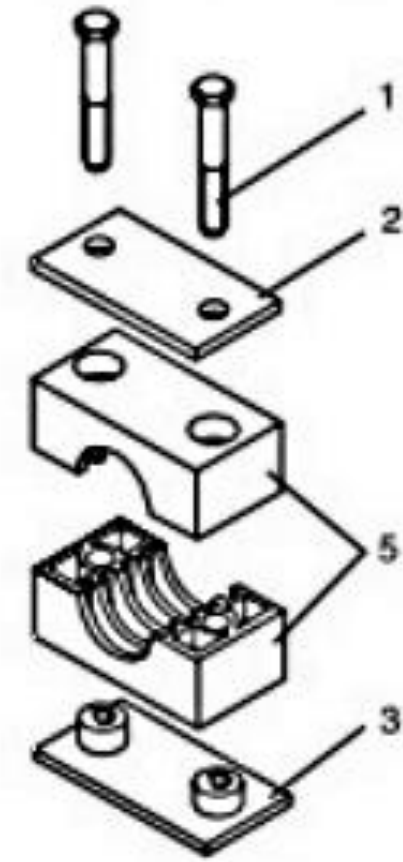

Single Clamp with  
Weld Plate









Assembly number:  
**AHL-00001**

### Parts Legend

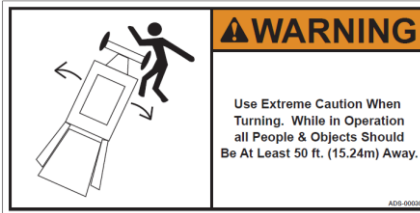

- |   |               |   |               |
|---|---------------|---|---------------|
| 1 | Hex Head Bolt | 5 | Clamp Pair    |
| 2 | Top Plate     | 6 | Stacking Bolt |
| 3 | Weld Plate    |   |               |
| 4 | Safety Plate  |   |               |



## Safety Decals

750464	Decal: High Pressure	
ADS-00011	Decal: Pinch Point	
ADS-00019	Decal: Grease Daily	
ADS-00030	Decal: Turning	
ADS-00041	Decal: Controls	
ADS-00046	Decal: Do Lifting	
ADS-00047	Decal: Tran. Lock	
ADS-00069	Decal: Am. Built	
ADS-00078	Decal: Laser Mast	

## Model Decals

ADS-00061	Decal: 25.75" x 5" <b>ASHLAND</b>
ADS-00064	Decal: "AI" 5.5" x 3.5" 
ADS-00066	Decal: Gauge 
ADS-00094	Decal: 3250SS Badge 





Your Ashland scraper is a durable piece of equipment and with proper care will yield many years of trouble-free operation. However, the life of your scraper can be severely shortened by poor maintenance. You must follow consistent maintenance practices and use superior quality grease and hydraulic oil (compatible with the power unit's hydraulic system) to insure the longest, most productive use from your scraper.

Your scraper should be greased at all points where grease fittings are provided. REMOVE TRANSPORT LOCKS prior to operation. Next, extend and retract all cylinders several times to force out any air from the hydraulic cylinders and lines. Check the oil levels in the tractor hydraulic system and add to maintain the proper level. Care should be used when adding oil or when disconnecting any oil line to keep all dirt out of the oil as dirt is a major factor in the failure of hydraulic components.

When your scraper is placed into operation, the operator will have to “feel out” the amount of depth of cut to obtain maximum loading efficiency. This is usually accomplished by taking a lesser and more uniform cut; however, some soil conditions such as loose sand may require a “pumping action” obtained by taking successive deep cuts and lifting out of cut as the tractor begins to lose power or traction.

After 8 hours of operation, all bolts should be checked and tightened if necessary and all grease fittings lubricated. Check tire pressures daily. Also, check pins and cutting edges for signs of wear.

After 50 hours work, all bolts should be rechecked and tightened if necessary. Check wheel bearings and adjust if necessary.

Check wheel lug nut torque.

- After first 2 hours of operation.
- Recheck daily for the next 2 weeks.
- Tighten wheel lug nuts in a star pattern.
- Torque wheel lug nut (see Torque Specifications).

After 300 hours work, clean and repack wheel bearings and replace, if necessary, cutting edges, worn pins, etc.



## **Failure to replace worn cutting edges may result in unnecessary wear to the machines sides and floor.**

Before starting a job, make sure Diggers Hot Line has been contacted and all underground utilities have been properly located (electric, phone, and pipelines). Have a clear understanding of all local, OSHA, and MSHA rules that apply to the job. Beware of your environment and keep others a safe distance from the machine while familiarizing yourself with the machine's controls. The scraper requires a power source with TWO 4-way (double acting) hydraulic control valves.



## **Scraper damage can occur if:**

1. The scraper is running over the haul road with the bowl fully raised. On scrapers that have factory installed nitrogen over hydraulic accumulators, the lift cylinders should be lowered 3 to 4 inches to allow the cushioned ride to work properly.
2. The heaped payload repeatedly exceeds the design ISO 6485 Earth-moving machinery-Tractor-scraper volumetric rating.
3. The fully loaded scraper exceeds the 10 mph on smooth haul roads and dramatically less on uneven haul roads.
4. The scraper is being top-loaded without the bowl being fully lowered to the ground prior to placing the material into the bowl.
5. The scraper is being used to level haul roads with the apron closed, not allowing material to enter the bowl.
6. The scraper is being used to load rock.
7. The scraper is being aggressively push loaded with a dozer.
8. A power unit that is above the horsepower rating is pulling the scraper.

**These types of damage are not covered under warranty. Warranty only covers defects in material or workmanship, not abuse because of improper use.**

## **Know the job:**

1. Know the weight of the material to be moved.
2. Lay the job out to take advantage of grades when loading.
3. Keep hauls as short as possible.
4. Keep haul roads smooth.
5. If more than one unit is in the job, make sure the haul roads are one-way and the operators understand the direction.
6. Brief the operators as to what the job consists of so there are no misunderstandings.
7. Know the moisture content of the material to be moved.
8. Will water be needed for proper compaction? Will drainage be a problem?
9. How many units will be needed to efficiently complete the job?



## **Transport the scraper safely:**

1. Always empty the scraper.
2. Clean all material from the exterior of the scraper.
3. Make sure all road rules are followed.
4. Use proper lighting and flagging.
5. Lower scraper bowl to provide just enough clearance over obstacles.
6. Transport at a safe speed to avoid roll-over.
7. Reduce speed on curves and when going downhill.

## **Apron Opening Guidelines:**

You will need to determine the ideal opening for your soil condition. It is important to have the apron opened prior to loading. To receive the highest production possible, it is important to know the typical characteristics of the material that you will be loading. In heavier soils like clay or gumbo, the soil will slab up and remain together after being cut by the blades. In lighter soils, like sand or dry/loose top soil, the material will pile up or push after being cut by the blade. Use the suggestions listed below:

### **Topsoil with heavy vegetation (12" to 24" opening):**

- When cutting undisturbed soils, you will need to open the apron high enough to allow debris to easily enter the scraper bowl. If the apron is opened too high, the rolling up sod will fall out past the apron and hinder the incoming material. If the apron is not adjusted quick enough, the material will bunch or push ahead of the machine. If this happens, you should close the apron and pull out the cut quickly. If you wait too long, you may develop too large a pile to clear the scraper while rising out of the cut. This can cause the power unit to lose traction and possibly cause you to get stuck.

### **Clay or loamy material: (6" to 12" opening):**

- To cut clay or loam soils, lower the apron to approximately 6" to 12" between the blades and the bottom of the apron. When you first lower the bowl, you'll see the material being cut by the blades and entering the bowl. As you continue to move forward, small clumps will fall past the apron and develop a small pile ahead of the apron. By limiting this apron opening, the small pile will "blade off" any loose material ahead of the machine. Adjustments should be made if large objects such as rocks or deep gouges are within the cut.

### **Sand or loose topsoil (15" to 30" topsoil):**

- Loading sand or loose top soil is the most difficult type of soil to load. In combination with the larger apron opening, you'll want to operate at a faster ground speed. By traveling faster and lowering the blade deeper than normal, it forces the material into the scraper bowl.

We encourage you to experiment with different apron openings to determine the best condition for your jobsite. The Apron is designed to capture material inside of the scraper bowl and should not be used as a leveling blade. Obstructions like large rocks or dense piles may cause the apron to bend inward after prolonged exposure to these conditions.



## Safety Signal Words:

Please note the use of signal words such as DANGER, WARNING, and CAUTION paired with the safety messages on your scraper. The appropriate signal word for each safety message has been selected using the following guidelines:

- **DANGER:** Indicates an imminently hazardous situation that, if not avoided, will result in death or significant injury. This signal word is limited to the most extreme situations – typically for machine components which, for functional purposes, cannot be guarded.
- **WARNING:** Indicates a potentially hazardous situation that, if not avoided, could result in death or significant injury. For example, hazards that are exposed when guards are removed. This signal word may also be used to alert against unsafe practices.
- **CAUTION:** Indicates a potentially hazardous situation that, if not avoided, may result in minor or moderate injury. This signal word may also be used to alert against unsafe practices.

Operator safety is a main concern in designing and developing equipment. Designers and manufacturers include as many safety features as possible. However, every year many accidents occur on job sites which could have been avoided by extra thought and a more careful approach to handling equipment. The operator can avoid many accidents by observing the precautions in this section. To avoid personal injury, study the following precautions and insist those working with, or for you, follow them.

Replace any CAUTION, WARNING, DANGER, or instruction safety decal that is not readable or missing.

Do not attempt to operate this equipment under the influence of drugs or alcohol.

Review the safety instructions in the operator's manual with all users annually.

**Operators should be responsible adults who are familiar with machinery and trained in the equipment's operations. Do not allow persons to operate or assemble this unit until they have read this manual and the owner's manual and have developed a thorough understanding of the safety precautions and scraper operation.**

# Tire Inflation & Torque Chart



Tire Inflation: PSI @ 6mph				
Model			Tire Size	Max PSI @ 6mph
3250SS			11L-15 12Ply	50

**NOTE: ALWAYS CONSULT THE TIRE MANUFACTURER FOR RECOMMENDED OPERATING TIRE PRESSURE (PSI).** TRAVEL SPEED, GROUND MATERIAL, LOADED WEIGHT, CLIMATE CONDITIONS, ETC. SIGNIFICANTLY EFFECT THE RECOMMENDED TIRE PRESSURE. UNDERFILLING OR OVERFILLING BASED ON YOUR UNIQUE OPERATING CONDITIONS MAY LEAD TO PREMATURE WEAR OR CATASTROPHIC FAILURE OF THE TIRES.

**On new machines, wheel hardware must be retorqued after the first 2 hours of operation.** Check tires daily to ensure correct inflation levels with an accurate gauge having 6.9 kPa [(0.07 bar) 1 PSI] gradations.

Also check for:

- Tire Damage
- Loose or missing wheel studs, nuts, or caps
- Uneven wear
- Damaged Rims

Torque Foot/Pounds	Wheel Bolt/Stud Size
80 – 90	1/2"-20
85 – 100	5/8"-18
450 – 500	3/4"-16
450 – 500	M22 x 1.5
750 – 800	1-1/8"-16



**The task of servicing tires and wheels can be extremely dangerous and should be performed by trained personnel only, using the correct tools and following best-practice. Do not attempt to mount, demount, or inflate a tire if you do not have the proper equipment and experience to perform the job. Call a qualified repair service to inspect the assembly and make necessary repairs. Failure to heed warnings could lead to serious injury or death.**

Visually inspect tires and wheels daily. Carefully inspect any rim and tire assembly that has been run underinflated or flat before reinflating the tire to make sure there is no damage to either the rim or tire.

- ALWAYS wear personal protection equipment such as gloves, footwear, eye protection, hearing protection, and head gear when servicing tire and wheel components.
- DO NOT operate with damaged rims, tire cuts or bubbles, missing lug bolts, or nuts or damaged rims.
- ALWAYS maintain the correct tire pressure. NEVER exceed recommended tire inflation pressure.
- INSPECT any rim and tire assembly that has been run flat or severely underinflated before reinflating the tire. Damage to the rim and tire may have developed.
- NEVER reinflate a tire that has lost air pressure or has been run flat without determining and correcting the problem.
- NEVER try to repair wheel, rim, or tire components parts. Parts that are cracked, worn, pitted with corrosion, or damaged must be discarded and replaced with good parts.
- ALWAYS use approved tire and rim combinations for the model scraper that you have and verify that part numbers of components are correctly matched for the assembly.
- ALWAYS exhaust all air from the tire prior to demounting.
- ALWAYS place wheel and tire assemblies in restraining devices (safety cage) when inflating tires. Use a clip-on chuck and long extension hose to allow you to stand to the side of the tire and not in front of it.
- NEVER weld or cut on an inflated tire assembly. Welding heat can cause increased pressure which could result in tire explosion.
- ALWAYS use proper lifting techniques and mechanized lifting aids to move heavy components and assemblies.
- NEVER leave a tire, wheel, or assembly unsecured in a vertical position.
- ALWAYS take care when moving tires and wheels, making sure that other people in the area are not endangered.



## Maintenance Schedule

- Daily visual inspection
- Thorough inspection for leaks or damage every 300 hours of operation
- 5 pumps of grease every 300 hours of operation
- Thorough cleaning, inspection, and repacking every 1,500 hours of operation

The bearings within the hubs of the scraper are fully greased with an **EP Rated ISO 220 NLGI #2 Lithium Complex** blue grease at the factory. Ashland uses a special bearing grease packer to ensure the bearing is effectively and evenly lubricated. Generous amounts of additional grease are added on both sides of the bearing prior to install within the hub.

## Lithium Complex Grease

Only high-performance, Lithium Complex grease is used to protect equipment in severe applications. The NLGI #2 ISO 220 EP Rated grease has excellent adhesion, structural stability, and is resistance to wet environments, making it suitable for use in a wide variety of machinery and components. This grease exhibits excellent wear, rust, and corrosion protection to help with mechanical efficiency, enhancing both bearing and equipment life. Overall, reducing maintenance costs, energy consumption, and providing protection at high and low temperatures.

## Recommended Products (compatible to mix):

Mobilgrease XHP 222

Chevron Delo EP NLGI 2

Shell Gadus S3 V220C 2

## Reinstalling Hubs

Before installing or re-installing the hub, follow this procedure to ensure spindle machined surfaces are clean and undamaged.

- Remove old lubricant and thoroughly clean spindle.
- Inspect machined spindle seal surface for nicks, scratches, burrs or marks. If needed, use crocus cloth or emery cloth to repair damaged areas.
- Clean spindle threads thoroughly with a wire brush to avoid false bearing adjustments and to avoid introduction of contaminants into the hub.
- Thoroughly clean spindle machined surfaces of rust, dirt, grease, or other contaminants that could damage the hub seal and cause it to leak.

## Caution

Too much grease volume (over-greasing) in a bearing cavity will cause the rotating bearing elements to begin churning the grease, pushing it out of the way, resulting an increase of bearing component temperatures. This leads to rapid oxidation (chemical degradation) of the grease as well as an accelerated rate of oil bleed, which is a separation of the oil from the thickener. The heat that has been generated over time along with the oil bleed eventually will cook the grease thickener into a hard, crusty build-up that can impair proper lubrication and even block new grease from reaching the core of the bearing. This can result in accelerated wear of the rolling elements and then component failure.



With proper care and maintenance, your Ashland Scraper will give many years of reliable service. When a situation arises where the earthmover performance is not satisfactory, this section will give some pointers on finding and correcting the problem.

## **Grease zerk will not take grease:**

1. Grease zerk plugged.
  - Remove and replace grease zerk.
2. Pin is frozen.
  - Remove, clean, and inspect pin.
  - Replace pin if necessary.
3. Bushing grease passage is not aligned with grease zerk.
  - Remove, clean, inspect, and realign bushing.
  - Replace bushing if necessary and realign.

## **Rollers do not roll:**

1. The rollers need lubrication.
  - Check zerk hole and grease, if applicable.
  - Remove pin, clean, inspect, and replace if necessary.
2. The roller bushing is worn out.
  - Remove roller assembly and replace bushings.

## **Cylinder will not hold in present position, i.e. the cylinder creeps:**

1. Seals leaking internally.
  - Remove and replace seal kit.

## **Machine cuts unevenly:**

1. Cutting edges worn unevenly.
  - Replace cutting edges.
2. Improperly inflated tires.
  - Check air pressure in tires.



# Warranty Statement



## The Purpose of Warranty

Ashland Industries, Inc. warrants each new product to be free from defects in material and workmanship. This warranty is applicable only for the normal service life expectancy of the product or components, not to exceed one year from the date of delivery of the new Ashland Industries product to the original purchaser, or the date the product is first put into service via a rental agreement or other means, whichever occurs first.

## Dealers Responsibilities

The following responsibilities are to be performed when the dealer delivers a product to the purchaser or otherwise places it into warranty service:

- Complete the Warranty Registration Form and forward it to Ashland Industries within 30 days of the sale, rental or other use of the product. Warranty reimbursement is contingent upon product registration.
- Review the warranty statement and operator's manual with purchaser to assure understanding of purchaser's responsibilities as related to warranty, service, and the proper and safe operation of the product. Purchasers/Renters should be advised to have failed parts repaired or replaced immediately upon failure, as continued use will result in additional damage, excessive wear, and may result in personal injury.
- Contact Ashland Industries prior to beginning repair or replacement of failed parts to make certain that the cost of repairs are consistent with the value of the product being sold.
- Warranty requests for units in dealer's inventory may be submitted to Ashland Industries when defects are noted in products prior to the retail sale or rental of that unit.
- Provide warranty and service repairs as directed by Ashland Industries' "Service Repairs Bulletins" or other instructions.
- All warranty work must be completed within 30 days of failure. Notify Ashland Industries' warranty department if repairs will require more than 30 days after failure for an extension. No claim will be accepted for warranties that exceed this 30 day period.
- No warranty will be allowed on units delivered to the retail customer prior to the full payment of that unit to the manufacturer by the dealer.
- If diagnostic time is required, contact Ashland Industries prior to beginning the warranty repair for approval. Ashland Industries must approve travel time reimbursement prior to beginning the warranty repair.

## Ashland Industries Responsibilities

- Reimbursement for parts used in warranty repair will be credited only when the parts are purchased from Ashland Industries Inc. Parts will be credited at dealer's net cost. No warranty will be allowed on parts that are past due.
- Dealer should use parts from their parts inventory first. In the event that parts must be shipped from Ashland Industries Inc., freight will be paid by Ashland Industries and will be shipped by the most economical means to arrive in the shortest possible time. Air, Next Day Air, Priority and other special shipment methods requested by the dealer will be at the customer's expense.

# Warranty Statement



## Ashland Industries Responsibilities (Cont'd)

- Warranty Labor Reimbursement for labor expense to the dealer is made by payment of the established hourly shop rate.
- Repair times will be reviewed by Ashland Industries and may be adjusted to average repair time required by other dealers to make similar repairs. Labor is not paid on the warranty associated with repair parts purchased by the retail customer that are used on a product that is not currently in warranty time frame.
- Reimbursements for repairs made by an outside source (not dealer personnel) will be made for those services deemed necessary for the resolution of the warranty by Ashland Industries' warranty department. Outside repair invoices must have prior approval from Ashland Industries' service department and must be attached to the warranty claim after approval.

## Other Warranty Provisions

The following guidelines are to be followed when performing warranty repairs:

- In all cases, the most economical repair should be performed unless otherwise directed. Credit will not be allowed for assemblies or groups if it is practical to make the repair with individual parts. In some cases, the assembly or group price may be less than the total of the parts and labor required to complete the repair. In those cases, an assembly or group may be used.
- Only those parts provided by Ashland Industries are covered under Warranty. The use of parts from other sources will not be eligible for warranty consideration.
- All parts removed during warranty repair should be held for a period of 90 days after the warranty claim has been submitted to Ashland Industries. These parts can be discarded if disposition or return request has not been made during this period. Parts that are requested must be returned within 30 days of claim disposition. These parts will be discarded after the 30 day period.
- Ashland Industries reserves the right to deny or reverse any and all warranty claims for parts, labor, or miscellaneous charges when errors are found, warranty provisions are abused, or fraudulent claims are submitted.

## Warranty Reimbursement is Not Possible

- When failure falls under the "limitations" as identified in Ashland's Limited Warranty Statement.
- When Ashland Industries has requested the return of certain parts, assemblies, or information and has not received the material within 30 days of date posted on return request.
- On claims due to damage or shortage that are obviously the responsibility of dealer or the delivering carrier.
- On the entire claim when warranty policy and provisions are not followed.

**All dealers will warranty their technician's work to the purchaser and will indemnify Ashland Industries, Inc. from such claims.**

# Warranty Statement



## Service Bulletins

Service Bulletins will be issued when necessary to alert dealers of special repairs. Each bulletin will give detailed directions and procedures to complete the service.

## Procedures For Completion Of Warranty Form

Complete the warranty form available at [www.ashlandind.com](http://www.ashlandind.com) or in your dealer's yellow Ashland Sales Book. Return this form to Ashland Industries within 30 days of failure.

## Use of Photographs

Pictures of the failure are recommended but not required. Photos should be attached to dealer's claim when their inclusion will help identify the condition of the part being repaired or replaced, and thus assisting in approval of the claim. In many cases, the use of photos may eliminate the need to return parts for evaluation. Photos will not be returned unless specifically requested. Digital photos are preferred and can be email to [warranty@ashlandind.com](mailto:warranty@ashlandind.com).

## Delayed Warranty Repairs

Warranty repairs should be scheduled and performed as soon as possible after notifying your dealer and Ashland Industries. There may be circumstances that require the use of the product for a short period of time by the retail customer, or the availability of repair parts may require the work to extend past a 30 day period. In these cases, the dealer must notify Ashland Industries in writing of the extenuating circumstance and advise that the continued use of the product will not enlarge the warranty claim. These claims will then be processed as if the product is still within the warranty period.

## Denied Claim

Dealers will be notified of a denied claim and notification will state the reason for denial. A dealer has the right to appeal this claim and must do so within 30 days of notification of denial. If there has been no appeal within the 30 day period, the claim will be considered closed.

## Limited Warranty Statement

Ashland Industries, Inc. warrants each new product to be free from defects in material and workmanship. This warranty is applicable only for the normal service life expectancy of the product or components, not to exceed one year from the date of delivery of the new Ashland Industries, Inc. product to the original purchaser, or the date the product is first put into service via a rental agreement or other means, whichever occurs first.

The major components of swivel hitches used on scrapers are warranted for three consecutive months from the date of delivery of the new Ashland Industries, Inc. product to the purchaser, or the date the product is first put into service via a rental agreement or other means, whichever occurs first, except those components described below.

Genuine Ashland Industries, Inc. replacement parts and components will be warranted for 30 days from date of purchase, or the remainder of the original equipment warranty period, whichever is longer.

Under no circumstances will it cover any merchandise or components thereof, which in the opinion of the company, has been subjected to misuse, unauthorized modification, alterations, an accident, or if repairs have been made with parts other than those obtained through Ashland Industries, Inc.

# Warranty Statement



## Limited Warranty Statement (Cont'd)

Ashland Industries, Inc. in no way warrants tires since their respective manufacturer warrants these items separately. Please call Ashland Industries, Inc. to receive phone numbers of tire suppliers. Ashland Industries, Inc. in no way warrants wearable items such as cutting edges, front dolly wheel balls, sockets, rollers, bushings, yoke hitch pins, hitch bushings, etc.

Our obligation under this warranty shall be limited to repairing or replacing, free of charge to the original purchaser, any part that, in our judgement, shall show evidence of such defect, provided further that such part shall be returned within 30 days from the date of failure to Ashland Industries, Inc. routed through the dealer and distributor from whom the purchase was made, transportation charges prepaid. Upon warranty approval, proper credits will be reimbursed for transportation.

This warranty shall not be interpreted to render Ashland Industries, Inc. liable for injury or damages of any kind or nature to person or property. This warranty does not extend to the loss revenue, extra labor cost associated with downtime, substitute machinery, rental, or for any other reason.

Except as set forth above, Ashland Industries, Inc. shall have no obligation or liability of any kind on account of any of its equipment and shall not be liable for special or consequential damages. Ashland Industries, Inc. makes no other warranty, expressed or implied, and, specifically, Ashland Industries, Inc. disclaims any implied warrant or merchantability or fitness for a particular purpose. Some states or provinces do not permit limitations or exclusions of implied warranties or incidental or consequential damages, so the limitations or exclusion in this warranty may not apply.

This warranty is subject to any existing conditions of supply which may directly affect our ability to obtain materials or manufacture replacement parts.

Ashland Industries, Inc. reserves the right to make improvements in design or changes in specifications at any time, without incurring any obligation to owners of units previously sold. No one is authorized to alter, modify, or enlarge this warranty nor the exclusion, limitations, and reservations.

## Owner Registration

Be sure to complete the Owner Registration form that you received with your machine and return it to Ashland Industries within 30 days of the sale, rental, or other use of your product. Warranty reimbursement is contingent upon product registration. If your product is not registered, it is NOT covered under warranty.