

# Ashland

## EARTHMOVERS

*Quality  
Equipment  
since 1953*

---

# Models 45 & 50

# PARTS MANUAL

---

**Version 3-2007**

Ashland Industries Inc.  
1115 Rail Drive  
P.O. Box 717  
Ashland, WI. 54806  
Ph: 877-634-4622 Toll Free  
Ph: 715-682-4622  
Fx: 715-682-9717  
[www.ashlandind.com](http://www.ashlandind.com)

MEMBER



CONSTRUCTION INDUSTRY  
MANUFACTURERS ASSOCIATION





**Models 45S, 45D & 50S, 50D**

## **HOW TO ORDER PARTS:**

### **IMPORTANT**

Parts must be ordered through your local authorized ASHLAND dealer. Be sure to state MODEL and SERIAL NUMBER of your machine, PART NUMBER, DESCRIPTION and QUANTITY needed.

Unless this is done, we cannot provide prompt service or assure shipment of the correct parts.



Ashland Industries weldable replacement parts are available to rebuild, modify or update your scraper to current factory specifications.

## **INDEX**

Page 3.	Operator and Maintenance Instructions
Page 4.	Safety Guidelines
Page 5-6.	Assembly Instructions
Page 7.	Frame Assembly
Page 8.	Pole, Axle & Wheel Assembly
Page 9.	Actuating Assembly
Page 10.	Bucket Assembly
Page 11.	Wheel, Hub & Spindle Assembly
Page 12.	Hydraulic Cylinder (4" x 16")
Page 13.	PMC-5600D Series
Page 14.	How to Operate the W7B-20DC Rim
Page 15.	Warranty Statement

# **OPERATORS AND MAINTENANCE INSTRUCTIONS**

This scraper is a durable piece of equipment and with proper care will yield many years of trouble free operation. The scraper requires a power source with TWO 4 way (double acting) hydraulic control valves.

The scraper should be greased at all points where grease fittings are provided. Connect hydraulic hoses to the tractor and retract lift cylinders to **REMOVE TRANSPORT LOCK PINS** (point A), then extend and retract all cylinders several times to force out any air from the hydraulic cylinders and lines. Check the oil levels in the tractor hydraulic system and add to maintain the proper level. Care should be used when adding oil or when disconnecting any oil line to keep all dirt out of the oil as dirt is a major factor in the failure of hydraulic components.

When the scraper is placed into operation, the operator will have to "feel out" the amount of depth of cut to obtain maximum loading efficiency. This is usually accomplished by taking a lesser and more uniform cut; however, some soil conditions such as loose sand may require a "pumping action" obtained by taking successive deep cuts and lifting out of cut as the tractor begins to lose power or traction.

1. After 10 hours work, all bolts should be checked and tightened if necessary.
2. Every 10 hours all grease fittings should be lubricated.
3. After 50 hours work, all bolts should be rechecked and tightened if necessary. Check wheel bearings and adjust if necessary.
4. After 300 hours work, clean and repack wheel bearings and replace, if necessary, cutting edges, worn pins, etc.



## SAFETY SIGNAL WORDS

Note the use of the signal words DANGER, WARNING and CAUTION with the safety messages. The appropriate signal word for each has been selected using the following guidelines:



**DANGER:** Indicates an imminently hazardous situation that, if not avoided, will result in death or serious injury. This signal word is to be limited to the most extreme situations typically for machine components which, for functional purposes, cannot be guarded.



**WARNING:** Indicates a potentially hazardous situation that, if not avoided, could result in death or serious injury, and includes hazards that are exposed when guards are removed. It may also be used to alert against unsafe practices.



**CAUTION:** Indicates a potentially hazardous situation that, if not avoided, may result in minor or moderate injury. It may also be used to alert against unsafe practices.



## GENERAL SAFETY GUIDELINES

Safety of the operator is one of the main concerns in designing and developing a new piece of equipment. Designers and manufacturers build in as many safety features as possible. However, every year many accidents occur which could have been avoided by a few seconds of thought and a more careful approach to handling equipment. You, the operator, can avoid many accidents by observing the following precautions in this section. To avoid personal injury, study the following precautions and insist those working with you, or for you, follow them.

Replace any CAUTION, WARNING, DANGER or instruction safety decal that is not readable or is missing. Location of such decals is indicated in this booklet.

Do not attempt to operate this equipment under the influence of drugs or alcohol.

Review the safety instructions with all users annually.

This equipment is dangerous to children and persons unfamiliar with its operation. The operator should be a responsible adult familiar with farm machinery and trained in this equipment's operations. **Do not allow persons to operate or assemble this unit until they have read this manual and have developed a thorough understanding of the safety precautions and of how it works.**

To prevent injury or death, use a tractor equipped with a Roll Over Protective System (ROPS). Do not paint over, remove or deface any safety signs or warning decals on your equipment. Observe all safety signs and practice the instructions on them.

Never exceed the limits of a piece of machinery. If its ability to do a job, or to do so safely, is in question - **DON'T TRY IT.**

## MODELS 45 & 50 SCRAPER ASSEMBLY INSTRUCTIONS

1. A suitable hoist or lift should be available for assembly.
2. Pack wheel bearing with grease and install hubs to rear spindles and front axle assembly. Be sure to follow the bearing numbers as shown in the parts listing as the front hubs require different bearings than the rear.
3. Raise actuating frame over bucket and lower into place so that the holes in the arms of the actuating frame align with the rear hole on each side of the bucket. Insert 1 ¼ " x 2-9/16" pin (with tab type head) from the inside of the bucket. Secure with 5/8" x 1 ¼ " NF bolt through bucket side with locking nut to the outside.
4. Connect actuating arm bars to the front holes in the bucket. In doing so, be sure that the cast roller on the opposite end of the actuating arm is in the up position and facing inward. Insert 1 ¼ x 2-9/16 " pin (with tab type head) from the inside of the bucket. Secure with 5/8" x 1 ¼ " NF bolt through the bucket side with locking nut to the outside.
5. Connect a short chain from the cutting edge to the cross pipe of the actuating frame, then raise this bucket and actuating assembly over the main frame and lower into place so that the front of the actuating frame can be connected to the 1 ½ " ID bearing on each side of the main frame. Secure with 1 ½ " x 5-5/8" pins on each side. Lock these pins in place by turning the pin until the hole in the head aligns with threaded hole in the actuating frame, then secure with ½" x 1" NC capscrew and lockwasher.
6. Lift front end of actuating arms and connect to the brackets on the front frame cross member using the 1 ¼ " x 4-1/8" pins. Secure with ¼" x 2" cotter pin.
7. Raise the apron assembly over the scraper and lower into position so that the holes in the arms of the apron align with the holes in the bucket sides. Insert the 1 ¼ " to 1" shoulder pin through the apron arms and into the bucket. Install lock nut inside the bucket and tighten securely.
8. Install hydraulic cylinders to main frame and actuating frame with rod end to actuating frame. Be sure the grease hole in the rod end is facing up. Use 1-1/8 x 3 ¼" pin at the base of the cylinder. Secure with 3/16" x 1 ½ " cotter pins. Use 1-1/8 " x 6" pin at the rod end of the cylinder. Secure with 1" x ½" NC capscrew and lockwasher.
9. Install 3/8" 90° swivel adapters into front and rear port on each cylinder. Tighten so that the hose connection faces the rear.
10. Connect a 3/8" x 18" hose from the rear port of each cylinder to one of the pipe lines on the rear cross frame. Be sure both hoses from the rear ports are connected to the same pipe line.
11. Connect a 3/8" x 38" hose from the front port of each cylinder to the remaining pipe line on the rear cross frame.

12. Raise the rear of the frame and install wheels to hubs. Also install wheels to front axle assembly.
13. Raise front of frame and remove the two 5/8" x 4" bolts which hold the cast socket halves inside the gooseneck. Remove the cast socket halves.
14. Roll the pole and axle assembly directly under the gooseneck, place the cast socket halves around the ball socket on the axle. Lower the frame into place so that the socket halves seat into the gooseneck. (If necessary, clamp halves together with C-clamp while inserting into gooseneck.) Replace 5/8" x 4" bolts and tighten securely. Install long shank grease fitting into the hole in the back side of gooseneck.
15. Install all the grease fittings and grease liberally.
16. If available, place assembled scraper on level floor or pavement and measure the distance from the cutting edge to floor, on both left and right sides, and then adjust axle spindle to obtain equal distance on both sides.

ASHLAND INDUSTRIES, INC.

Addendum:

There are mating surfaces between the offset bar of the actuating frame and the side wall of the bucket where a rubbing action occurs. Likewise, there is a spot between the offset bar of the actuating frame and the inside of the main frame on left and right sides. Apply a film of grease at these locations.

The rubbing action at these locations is intentional to support the bucket while in operation.

## FRAME ASSEMBLY

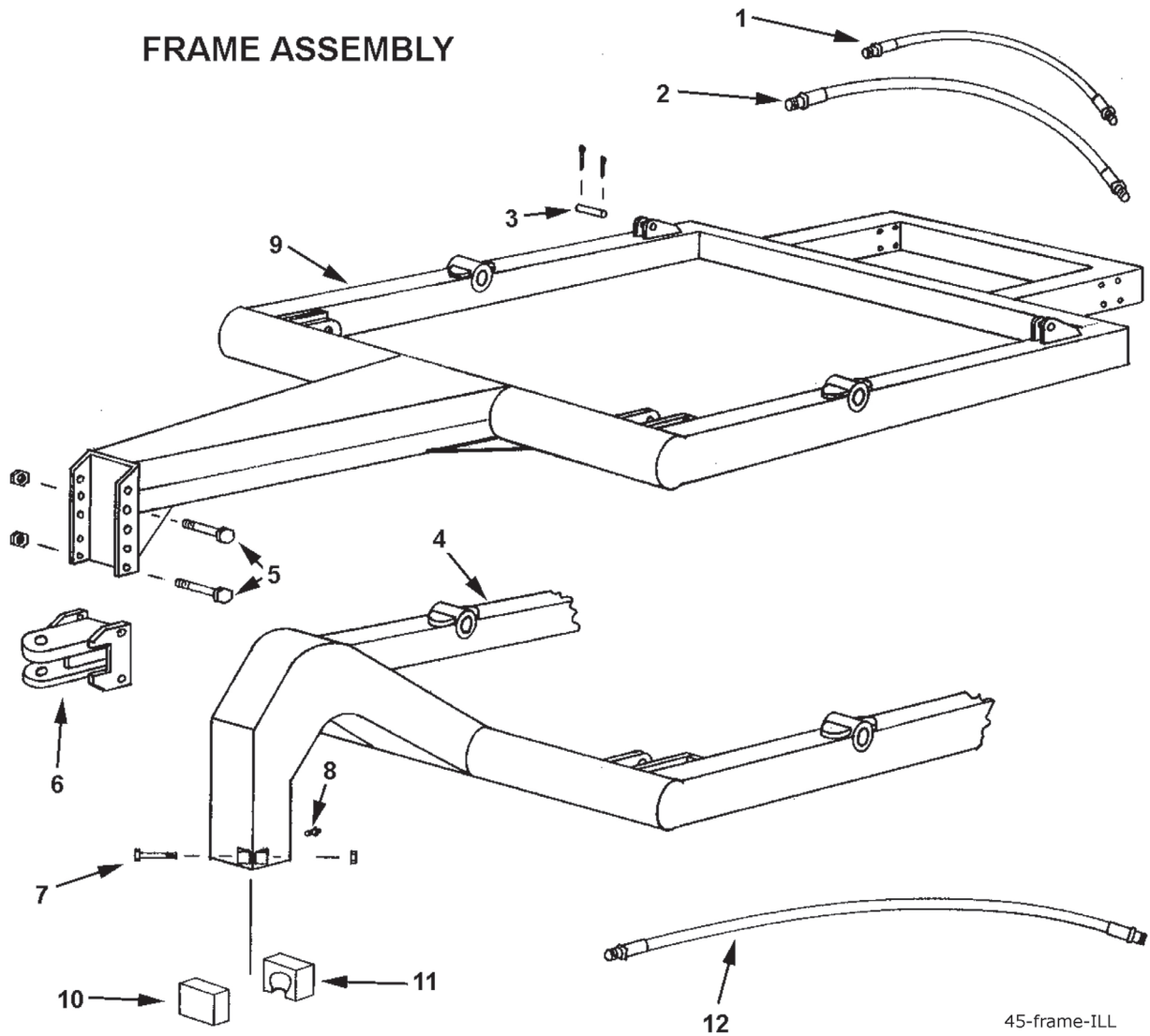

KEY NO.	PART NO.	DESCRIPTION
1	A450H01	Hydraulic hose, 3/8" x 18" single braid
2	A450H02	Hydraulic hose, 3/8" x 38" single braid
3	A22H03	Swivel adapter, 90°
4	A45003	Pin, 1-1/8" x 3-1/4", cotter both ends Cotter pin, 3/16" x 1-1/2"
5	A4551	Frame, four wheel, Model D Bolt, 3/4 x 6" NC w/ nut & LW
6	A4523	Hitch
7		Bolt, 5/8" x 4" NC w/ nut & LW
8	A2206	Grease fitting, 1-1/8" NPT strt. long
9	A4552	Frame, two wheel, Model S
10	A40004	Cast socket half
11	A40005	Cast socket half, rear w/ grease hole
12		Connecting hydraulic hose, 1/2" x 84" or 1/2" x 60"
13	A5004	Model 50 only - Swivel hitch
14		Model 50 only - Bolt, 1" x 6-1/2" NC w/ nut & LW
***	A022977-2	Hitch, Tractor 3 point, Category 2
***	A022977-3	Hitch, Tractor 3 point, Category 3

## POLE, AXLE & WHEEL ASSEMBLY

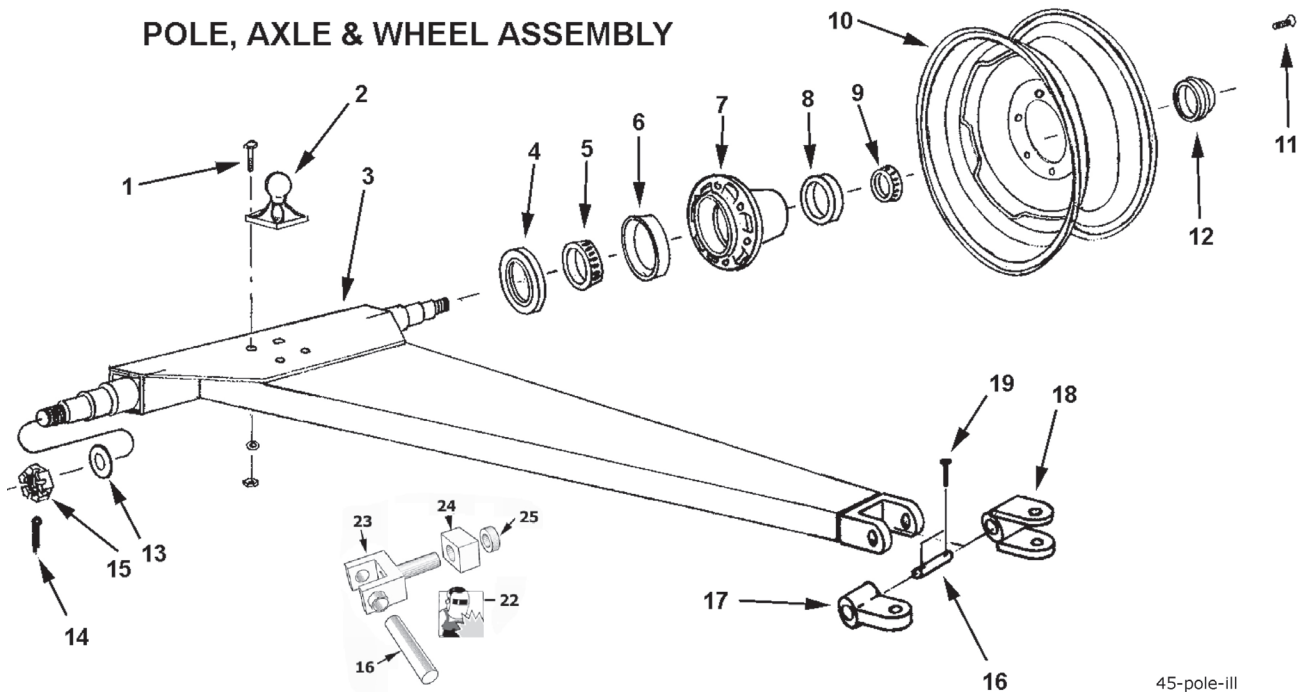

45-pole-iii

KEY NO.	PART NO.	DESCRIPTION
1		Bolt, 3/4" x 2-1/2" NC w/ nut & LW
2	A40006	Ball swivel
3	A5002	Pole & axle assembly Model 50, thru s/n 15279
	A4502	Pole & axle assembly Model 45
3A	A5005	Pole assembly Model 50 s/n 15280 & up
	A4505	Pole assembly Model 45
4	A2229A	Grease seal ( CR 20079 )
5	A2230A	Bearing cone, inner ( Timken 342S )
6	A2231	Bearing cup, inner ( Timken 332 )
7	A2232	Hub, less bearing cups
8	A2233	Bearing cup, outer ( Timken 14276 )
9	A2234	Bearing cone, outer ( Timken 14137A )
10	A3319A	Wheel, 15" x 8"
11	A2236	Wheel bolt
12	A2235	Hub cap
13	A2239	Washer, special 7/8" flat
14		Cotter pin, 5/32 x 1-1/4"
15	AFN-00005	Nut, 7/8" NF castellated
16	A6014	Pin, 1-1/4" x 5-3/4" w/ cotter pin holes
17	A4553A	Single lip hitch
18	A4553	Clevis hitch
19		Cotter pin, 1/4" x 2"
20	A5006	Model 50 only, Spindle bolt on, s/n 15280 & up
21		Model 50 only, Bolt, 1/2" NC x 5" lg., gr. 5 w/ nut & LW
22	A4553W	Swivel Hitch Rebuild Kit, includes items 16, 23, 24, 25.
23	A051068-2	Hitch: Swivel Yoke
24	A051368	Hitch: Swivel Block
25	A051368-2	Hitch: Retaining Collar



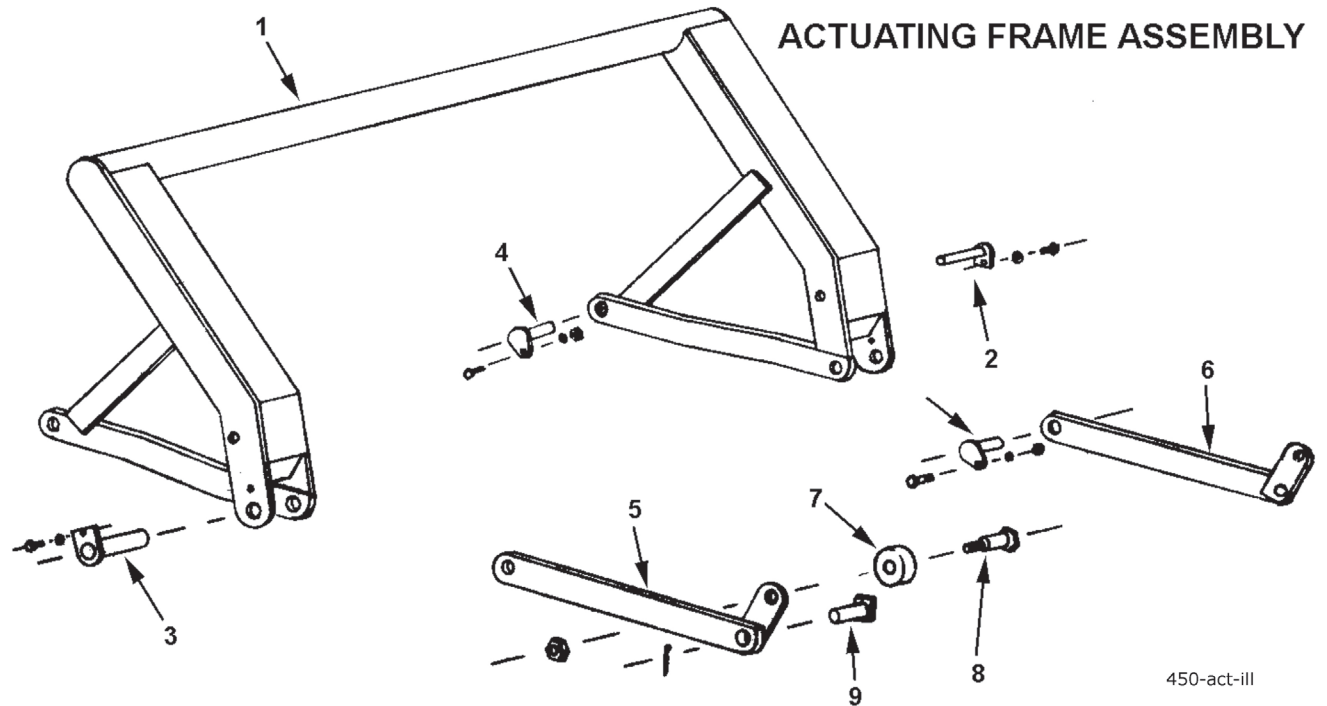

<b>KEY NO.</b>	<b>PART NO.</b>	<b>DESCRIPTION</b>
1	A45005	Actuating frame
2	A45006	Pin, 1-1/4" x 2-9/16" w/ locking head
3		Bolt, 5/8" x 1-1/4" NC w/ lock nut
4	A2502	Pin, 1-1/2" x 5-3/4"
5		Capscrew, 1/2" x 1" NC w/ LW
6	A4524	Pin, 1-1/8" x 6"
7	A30003	Shoulder pin, 2-1/2" shoulder, 1-1/4" to 1"
8	A30002	Nut, 1" NF lock nut
9		Roller
10	A6007A	Cotter pin, 1/4" x 2"
11	A45007	Pin, 1-1/4" x 4-1/8" w/ sq. head & hole for gr. zerk
	A45008	Actuating arm, left
		Actuating arm, right

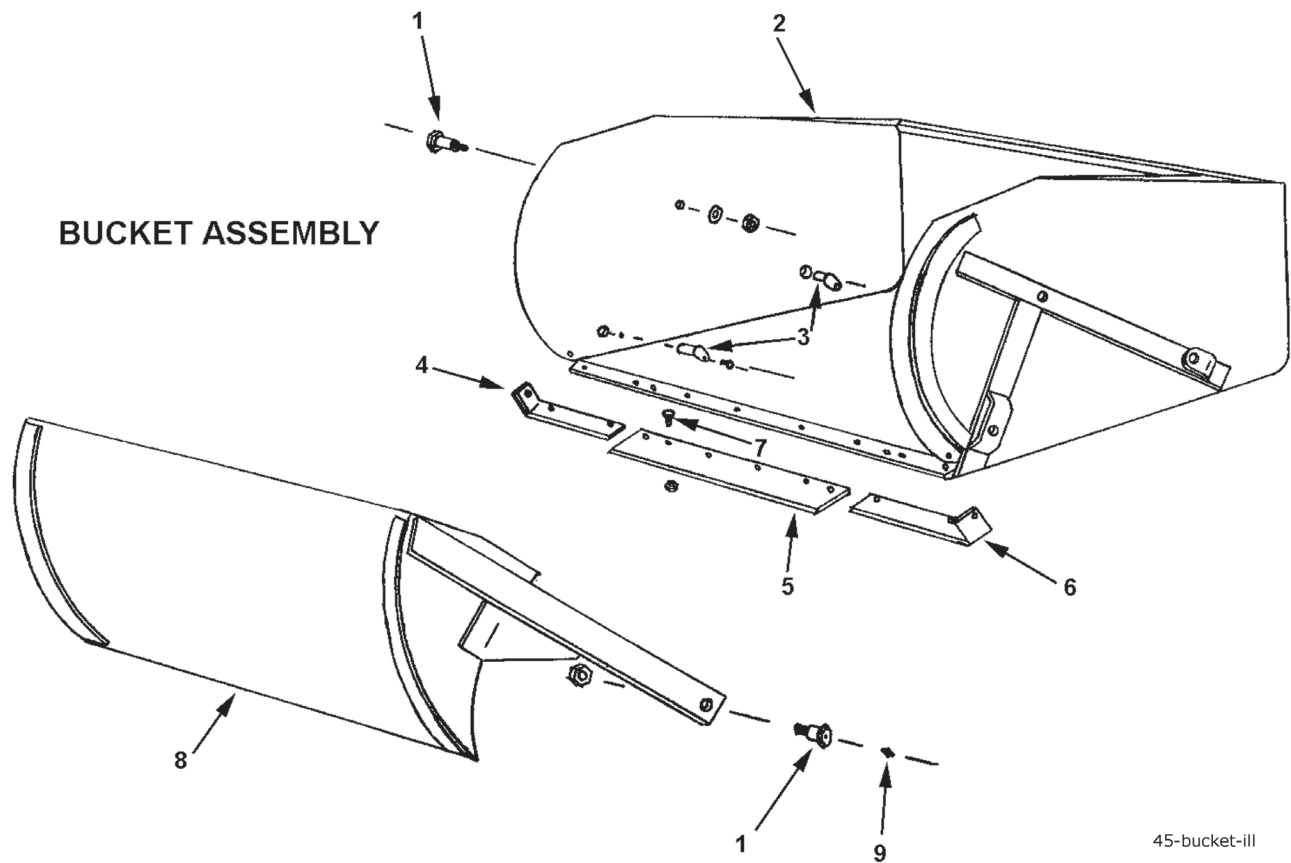

45-bucket-ill

KEY NO.	PART NO.	DESCRIPTION
1	A30020	Shoulder pin, 1-1/4" to 1" NF w/ ctsk hole Nut, 1" lock type
2	A5003	Model 50 Bucket
	A45009	Model 45 Bucket
3	A45006	Pin, 1-1/4" x 2-9/16" w/ locking head
4	A2225	Right cutting edge, 6"
5	A45010	Center, cutting edge, 8" x 50"
*	A45010-6	Optional straight blade to match corner blades
6	A2222	Left cutting edge, 6"
7		Plow bolt, 1/2" x 1-3/4" w/ nut Plow bolt, 5/8" x 2" w/ nut
8	A45011	Apron
9		Grease fitting, 1/8" NPT regular

\* (Serial number break)

## WHEEL, HUB & SPINDLE

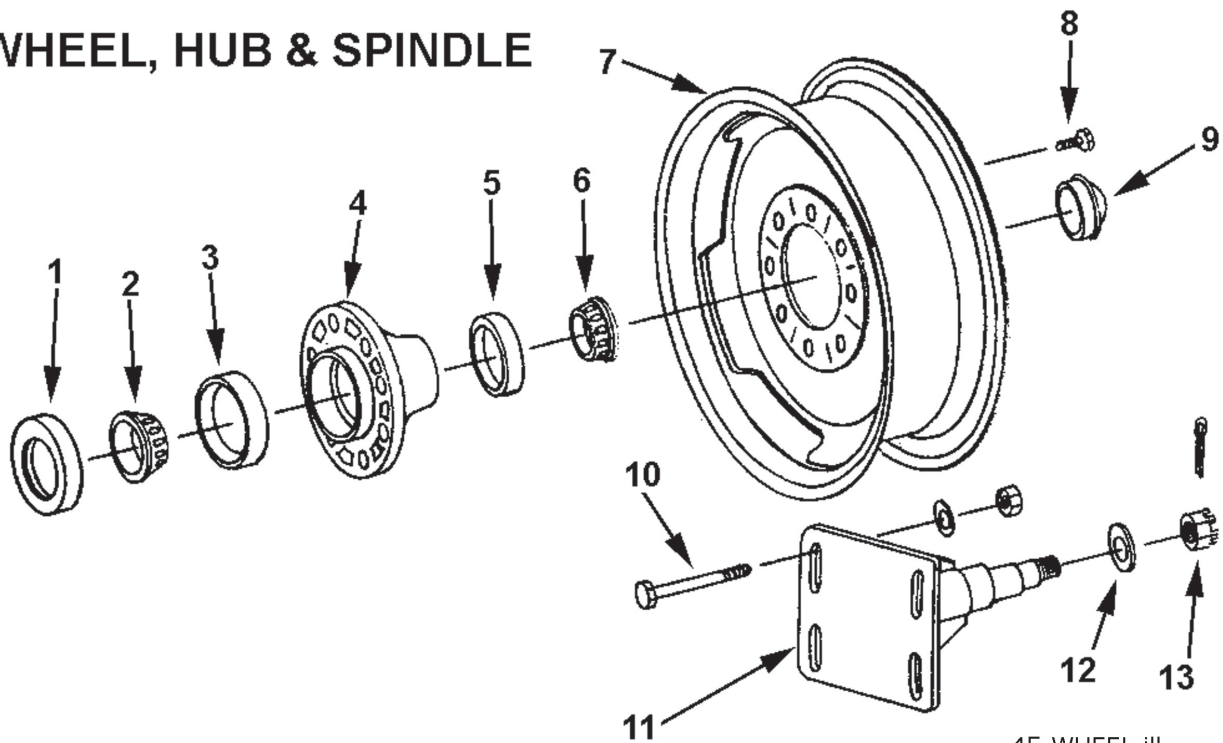

45-WHEEL-III

KEY NO.	PART NO.	DESCRIPTION
1	A4512	Grease seal ( National 415082 )
2	A4513	Bearing cone, inner ( Timken 3784 )
3	A4514	Bearing cup, inner ( Timken 3720 )
4	A4515	Hub, less bearing cups
5	A2233	Bearing cup, outer ( Timken 14276 )
6	A4516	Bearing cone, outer ( Timken 14137A )
7	*A4521A	Wheel, 20" D.C. (Model 50 only: up to sn 20667, 12/02)
	*A125047	Wheel, 22.5" x 8.25" (Model 50 only: sn 20668 & up, 01/03)
8	A4519	Wheel bolt
9	A2235	Hub cap
10		Bolt, 3/4" x 6" NC w/ nut & FW
11	A4520	Spindle
12	A2239	Washer, special 7/8" flat
13		Nut, 7/8" NF castellated Cotter pin

## HYDRAULIC CYLINDER 4" BORE X 16" STROKE

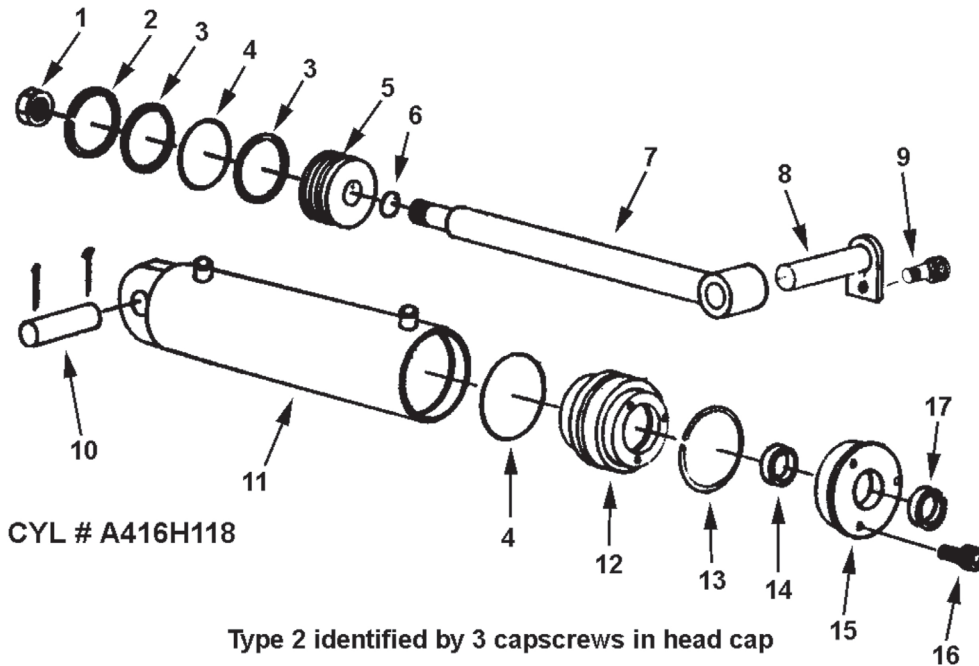

45-hyd cyl-ill

KEY NO.	PART NO.	DESCRIPTION
1	A300H03	Piston nut, 1" NF
2	A300H04	Cast iron ring, 4" OD
3	A300H05	Backup washer, 4" OD
4	A300H06	O-ring seal, 4" OD x 3/16"
5	A300H07	Piston, 4"
6	A45H05	Piston gasket, 1"
7	A45H03-118	Shaft, 1-1/2" dia.
8	A4524	Pin, 1-1/8" x 6"
9		Capscrew, 1/2" x 1" NC w/ LW
10	A45003	Pin, 1-1/8" x 3-1/4" Cotter pin, 3/16" x 1-1/2"
11	A45H04	Barrel assembly
12	A300H11	Head gland
13	A300H12	Retainer ring
14	A22H15	O-ring, 1-1/2" x 1/8"
	A22H15A	Backup washer
15	A300H13	Head cap
16	A22H18	Capscrew, 1/4" x 1" NC
17	A22H17	Wiper seal, 1-1/2" ID
	A300H14B	Packing kit, containing:
		1 - A300H04    2 - A22H15    2 - A300H05
		1 - A22H15A    2 - A300H06    1 - A22H17
		1 - A45H05

4" Bore  
16" Stroke  
2 Port

## PMC-5600D Series

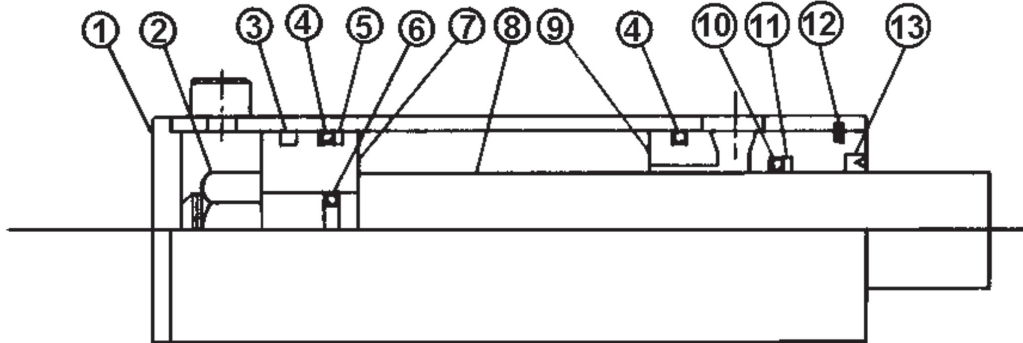

Type 4 identified by Snap ring securing gland

450-pmc-cyl-iii

KEY NO.	QTY.	PART NO.	DESCRIPTION
1	1	A45H04-P	Butt and tube assembly
2	1	A-2043-8	Lock nut
3	1	PMAP-R-45	Piston ring
4	2	PMAP-O-45	O-ring
5	1	PMAP-W-45	Bu-washer
6	1	PMAP-O-19	O-ring
7	1	P4-1130	Piston
8	1	A45H03-P	Piston rod
9	1	GIC-3940	Gland
10	1	PMAP-O-32	O-ring
11	1	PMAP-W-32	Bu-washer
12	1	PMAP-VB-32	Wiper
13	1	TSR-400	Snap ring
	1	PMCK-5600D	Packing kit



# HOW TO OPERATE THE W7B-20DC RIM

**Note:** This rim has been developed for 20" used truck tires up to and including 9.00-20 ten ply. However, many users have found it possible to mount 10.00-20 twelve ply tires. The following procedures should be followed:

**Tools and Materials Required:** One Set Firestone Truck Tire Tools (48-A-200)  
One Pair Vise-Grip Pliers  
Lubricant (Avoid use of compound that contains water . . . or a solvent injurious to rubber — see your rim distributor)

## MOUNTING:



1. Remove flap inasmuch as it is not required on the drop center rim mounting and it prevents mounting the tire. Check to see tube is in casing and inflated sufficiently to prevent sag below tire beads.



2. Place rim on floor with valve hole side up. Place tire over rim with valve stem pointing upwards. Force lower bead into well of rim as far as possible.



3. Lubricate last section of lower bead to facilitate mounting.



4. Using straight end of tool (with stop resting on rim flange) take small bites to work remaining section of lower bead onto rim.

5. Stand tire up with valve and valve hole at top of rim. Insert valve into valve hole.

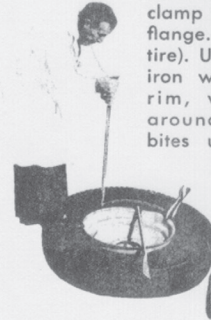

6. To get top bead in place stand on tire and force bead down as far as possible and clamp vice grip pliers on the flange. (snub side toward tire). Using spoon end of tire iron with lug side towards rim, work progressively around bead using small bites until bead slips over flange onto rim base. In order to mount last 6" of bead it usually is necessary to insert second tire iron and lubricate the last bead portion.

## DEMOUNTING:



1. Remove valve core to deflate and loosen tire from bead seat of rim on both sides. Lubricate upper bead of tire thoroughly. With stops toward rim, insert spoon ends of both tools about 10 inches apart. While standing on tire to hold bead in well, pull one tool back toward center of rim.

2. Hold first tool in position with one foot and pull second tool toward center of rim. Progressively work top bead off rim, taking additional bites if necessary.



3. Stand tire and tube in vertical position with valve at top of assembly and remove valve from valve hole. Then place valve at bottom of assembly and pull out upper portion of tube so it will not interfere with demounting the second bead. Lubricate second bead. At top of assembly insert straight end of tool between bead and back flange of rim at about a 45° angle. Turn tool so it is perpendicular to rim. Pry second bead off.



**ELECTRIC WHEEL COMPANY-QUINCY, ILL.**

Division of the Firestone Tire & Rubber Company

# Limited Warranty Statement

Ashland Industries Inc. warrants each new product to be free from defects in material and workmanship. This warranty is applicable only for the normal service life expectancy of the product or components, not to exceed **six consecutive months** from the date of delivery of the new Ashland Industries product to the purchaser, or the date the product is first put into service via a rental agreement or other means, whichever occurs first.

The major components of swivel hitches used on Industrial series scrapers are warranted for three consecutive months from the date of delivery of the new Ashland Industries product to the purchaser, or the date the product is first put into service via a rental agreement or other means, whichever occurs first, except those components described below.

Genuine Ashland Industries Inc. replacement parts and components will be warranted for 30 days from date of purchase, or the remainder of the original equipment warranty period, whichever is longer.

Under no circumstances will it cover any merchandise or components thereof, which in the opinion of the company, has been subjected to misuse, unauthorized modification, alterations, an accident or if repairs have been made with parts other than those obtained through Ashland Industries Inc.

Ashland Industries Inc. in no way warrants Tires since their respective manufacturer warrants these items separately. Please call Ashland Industries Inc. to receive phone numbers of tire suppliers.

Ashland Industries Inc. in no way warrants wearable items such as cutting edges, front dolly wheel balls, socket halves, rollers, bushings, yoke hitch pins, hitch bushings, etc..

Our obligation under this warranty shall be limited to repairing or replacing, free of charge to the original purchaser, any part that, in our judgement, shall show evidence of such defect, provided further that such part shall be returned within 30 days from the date of failure to Ashland Industries Inc. routed through the dealer and distributor from whom the purchase was made, transportation charges prepaid. Upon warranty approval proper credits will be reimbursed for transportation.

This warranty shall not be interpreted to render Ashland Industries Inc. liable for injury or damages of any kind or nature to person or property. This warranty does not extend to the loss revenue, extra labor cost associated with downtime, substitute machinery, rental or for any other reason.

Except as set forth above, Ashland Industries Inc. shall have no obligation or liability of any kind on account of any of its equipment and shall not be liable for special or consequential damages. Ashland Industries Inc. make no other warranty, expressed or implied, and, specifically, Ashland Industries Inc. disclaims any implied warrant or merchantability or fitness for a particular purpose. Some states or provinces do not permit limitations or exclusions of implied warranties or incidental or consequential damages, so the limitations or exclusion in this warranty may not apply.

This warranty is subject to any existing conditions of supply which may direct affect our ability to obtain materials or manufacture replacement parts.

Ashland Industries Inc. reserves the right to make improvements in design or changes in specifications at any time, without incurring any obligation to owners of units previously sold

No one is authorized to alter, Modify or enlarge this warranty nor the exclusion, limitations and reservations.

Ashland Industries Inc.  
Warranty Department