

Ashland

EARTHMOVERS

Parts Manual

ver. 1211

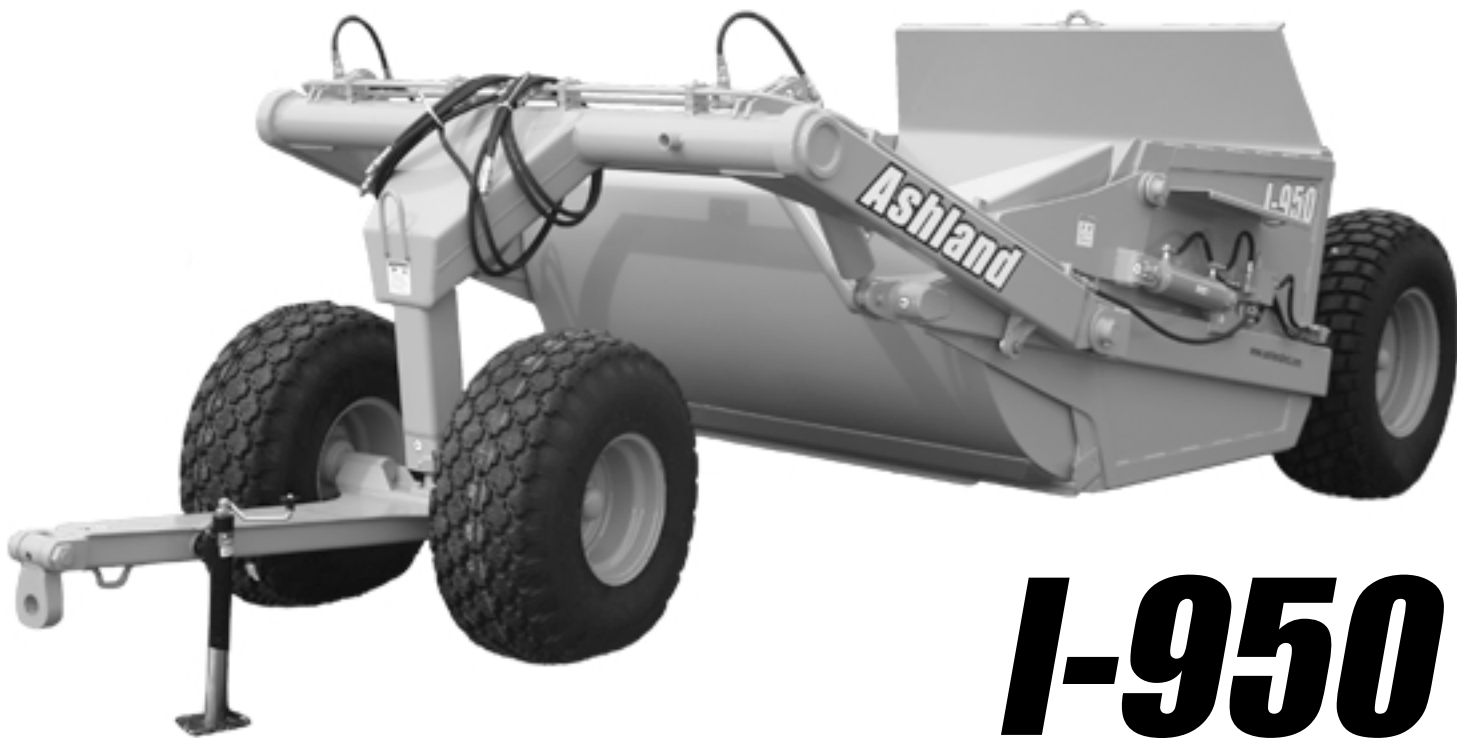

I-950

Ashland Industries

Crafting Quality since 1953!



1115 Rail Drive

P.O. Box 717

Ashland, WI U.S.A.

Toll Free: (877) 634-4622

Business: (715) 682-4622

Fax: (715) 682-9717

www.ashlandind.com

www.scraperdrawbar.com

Table of Contents

Categorized Listing

ASHLAND SCRAPERS	1
Serial Number	1
How to Order Parts	2
Operators and Maintenance	3
Safety Guidelines	4
XL Assembly	5
Gooseneck Frame Assembly (900-950)	6
Apron Assembly (950)	7
Bowl & Frame Assembly (900-950)	8
Push Off Assembly (900-950)	10
Pole & Axle Assembly (900-950)	12
Wheel Assembly (900-950)	14
Lift Cylinder (#A416H118) 4" X 16"	15
Apron Cylinder (#A125050) 4" X 13"	17
Push Off Cylinder (#A125111) 4" x 50"	18
Hydraulic Manifold (#A125174)	19
Hydraulic Valve Ports Assembly	20
Hydraulic Valve Seals	21
Hydraulic Plumbing Front (I-950)	22
Hydraulic Plumbing Rear (I-950)	23
Parts - Hydraulic Clamps	24
Hydraulic Hoses (I-950))	25
Decals Illustration (I-950)	27
Decals	28
Maintenance Check list	29
Torque Specifications	30
Tire Service	31
Pushing the Earthmover	32
Troubleshooting	33
Warranty Statement	34

ASHLAND SCRAPERS

Serial Number

WELCOME TO OUR NEW CUSTOMERS!

Thank you for your purchase of an Ashland scraper and the confidence you have placed in us to handle your earthmoving projects. Years of research, testing and successful application have been spent to ensure quality and maximum performance for our customers. Please read and understand this manual before attempting to attach or operate this scraper. This manual should always remain with the machine. Be sure and fill out and send in the owners registration form at the beginning of this manual, or you may fill out the form on-line by going to ashlandind.com and click on "Register your Machine" at the bottom of the page.

SCRAPER ID NUMBER

The serial number plate for the scraper is located on the right rear area of the scraper. The letter and numbers stamped identify the serial number, model number and capacity of the scraper. Please record this serial number for use in ordering parts, warranty issues and to trace your equipment if it is ever stolen.

References to serial number breaks on parts are located in the manual with a reference sequence of XXXXX-XXXXX. The beginning number records the serial number start of the use of that part. The ending number is the final serial number use of the part within this machine.



ASHLAND SCRAPERS

How to Order Parts

HOW TO ORDER PARTS:

IMPORTANT

Parts must be ordered through your local authorized ASHLAND dealer.

Be sure to state MODEL and SERIAL NUMBER of your machine, PART NUMBER, DESCRIPTION and QUANTITY needed.

Unless this is done, we cannot provide prompt service or assure shipment of the correct parts.



Ashland Industries weldable replacement parts are available to rebuild, modify or update your scraper to current factory specifications.

ASHLAND SCRAPERS

Operators and Maintenance

This scraper is a durable piece of equipment and with proper care will yield many years of trouble free operation. The scraper requires a power source with TWO 4 way (double acting) hydraulic control valves.

The scraper should be greased at all points where grease fittings are provided. Check the oil levels in the tractor hydraulic system and add to maintain the proper level. Care should be used when adding oil or when disconnecting any oil line to keep all dirt out of the oil as dirt is a major factor in the failure of hydraulic components.

When the scraper is placed into operation, the operator will have to “feel out” the amount of depth of cut to obtain maximum loading efficiency. This is usually accomplished by taking a lesser and more uniform cut; however, some soil conditions such as loose sand may require a “pumping action” obtained by taking successive deep cuts and lifting out of cut as the tractor begins to lose power or traction.

1. After 10 hours work, all bolts should be checked and tightened if necessary.
2. Every 10 hours all grease fittings should be lubricated.
3. After 50 hours work, all bolts should be rechecked and tightened if necessary. Check wheel bearings and adjust if necessary.
4. After 300 hours work, clean and repack wheel bearings and replace, if necessary, cutting edges, worn pins, etc.

ASHLAND SCRAPERS

Safety Guidelines



GENERAL SAFETY GUIDELINES

Safety of the operator is one of the main concerns in designing and developing a new piece of equipment. Designers and manufacturers build in as many safety features as possible. However, every year many accidents occur which could have been avoided by a few seconds of thought and a more careful approach to handling equipment. You, the operator, can avoid many accidents by observing the following precautions in this section. To avoid personal injury, study the following precautions and insist those working with you, or for you, follow them.

Replace any CAUTION, WARNING, DANGER or instruction safety decal that is not readable or is missing. Location of such decals is indicated in this booklet.

Do not attempt to operate this equipment under the influence of drugs or alcohol.

Review the safety instructions in the operator's manual with all users annually.

This equipment is dangerous to children and persons unfamiliar with its operation. The operator should be a responsible adult familiar with farm or construction machinery and trained in this equipment's operations. **Do not allow persons to operate or assemble this unit until they have read this manual and the owner's manual and have developed a thorough understanding of the safety precautions and how the machine works.**

To prevent injury or death, use a tractor equipped with a Roll Over Protective System (ROPS). Do not paint over, remove or deface any safety signs or warning decals on your equipment. Observe all safety signs and practice the instructions on them.

Never exceed the limits of a piece of machinery. If its ability to do a job, or to do so safely, is in question - **DON'T TRY IT.**

ASHLAND SCRAPERS

XL Assembly

SXL300A001

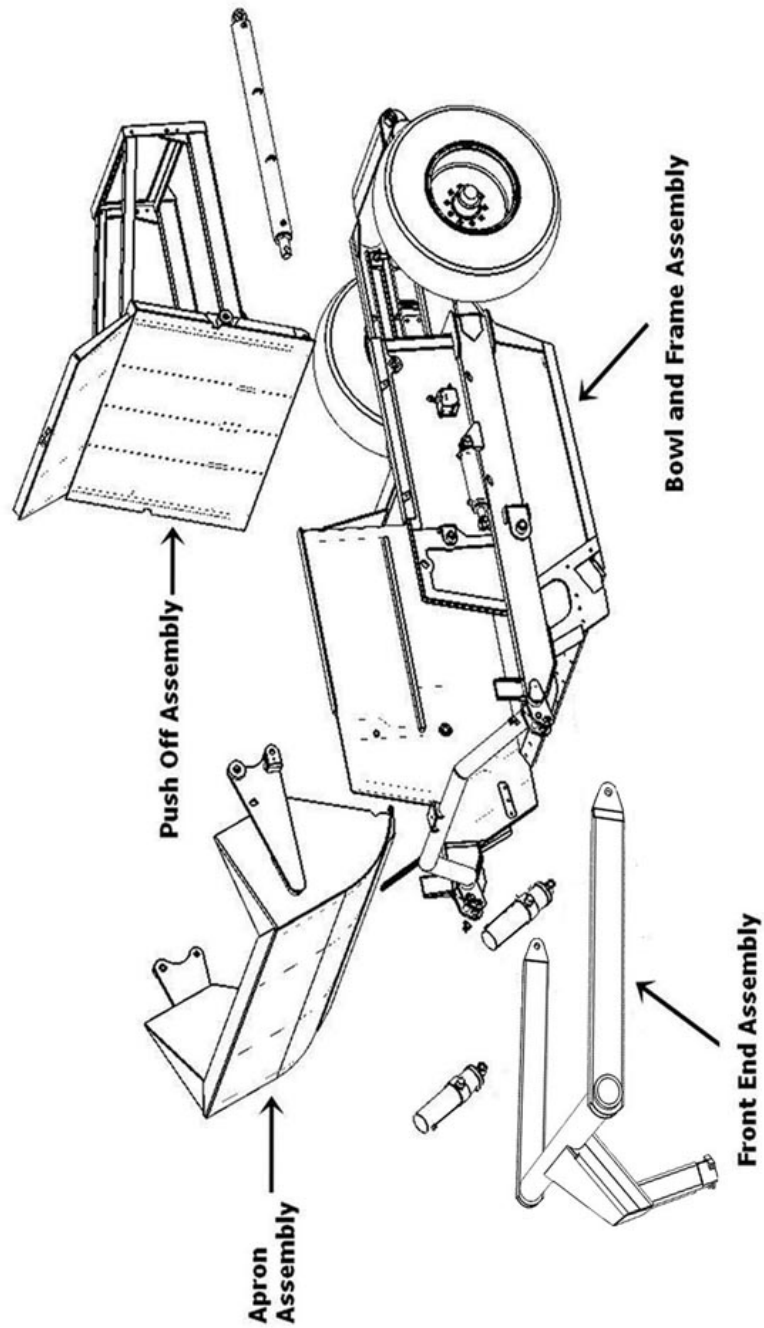

ASHLAND SCRAPERS

Gooseneck Frame Assembly (900-950)

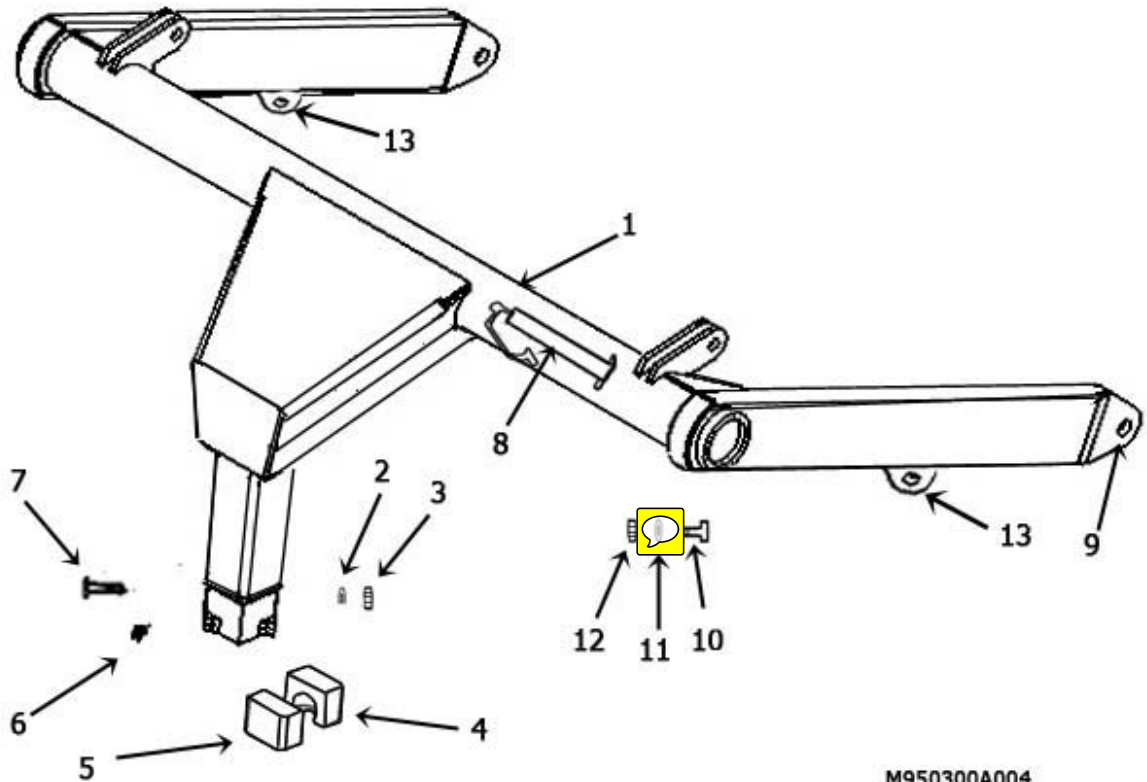

M950300A004

KEY	PART	DESCRIPTION	SN 950	REMARKS
1	600104	Gooseneck Frame (950)	22262-XXXXX	
2	8110	Lock washer 5/8"		
3	7536	Nut, 5/8" NF		
4	A90004	Cast Socket half, rear		
5	A90005	Cast Socket half, front with zerk hole		
6	A2206	Grease Zerk, Long Shank		
7	AFB-00043	Bolt, 5/8" x 4 1/2" NF		
8	OPT-00001	Hitch Jack		
9	AHF-00028	Grease Fitting 90° 1/8 NPT		
10	A030672-33	Travel Lock	22782-XXXXX	
	AFB-00018	Bolt: 1"NC X 3" Gr 8	XXXXX-22781	
11	A125006	Snap Ring	22782-XXXXX	
	AFW-00001	Washer 1" Flat	XXXXX-22781	
	AFN-00012	Nut: 1" NC Gr 8	XXXXX-22781	

ASHLAND SCRAPERS

Apron Assembly (950)

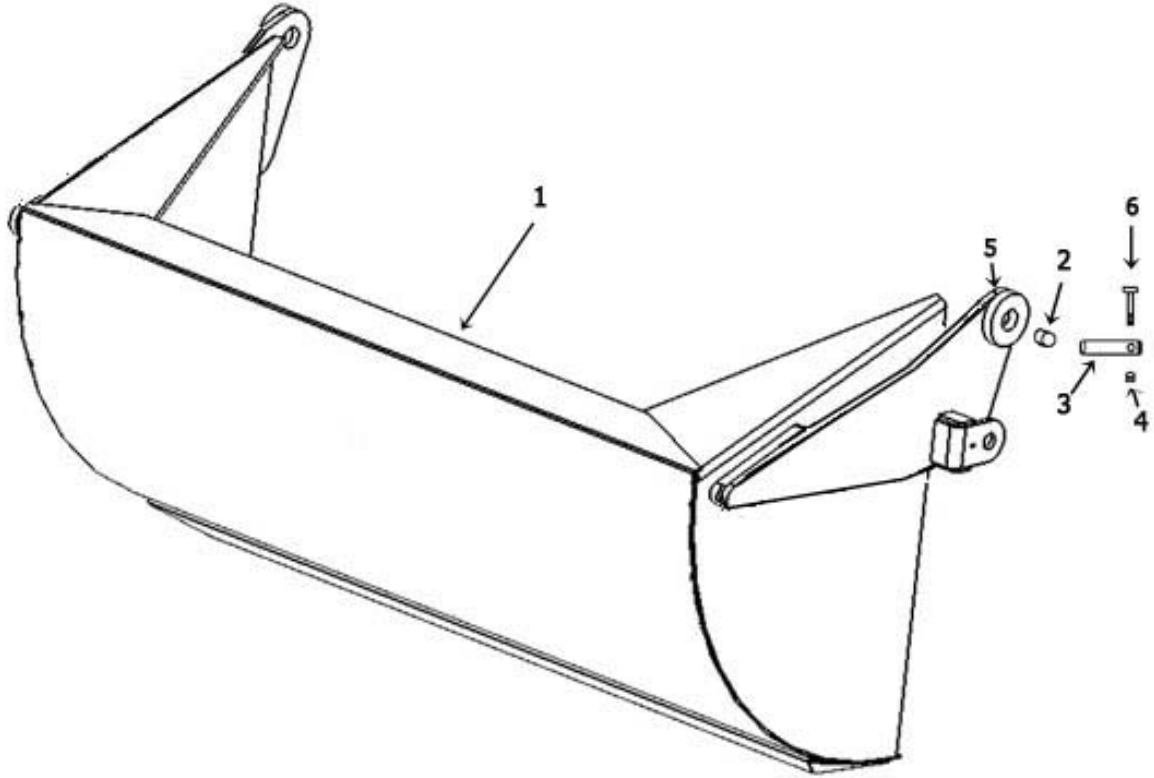

M950300A001

KEY	PART	DESCRIPTION	SN 950
1	600125	Apron	22395-XXXXX
2	A123343	Bushing: 2" OD X 1 1/2 ID X 1 3/4 L	
3	A123337	Pin: 1 1/2" X 5 3/8" L	
4	7450	Nut: 3/8 NC	
5	14505	Grease Fitting	
6	AFB-00049	Bolt: 3/8 NC X 3"	

Bowl & Frame Assembly (900-950)

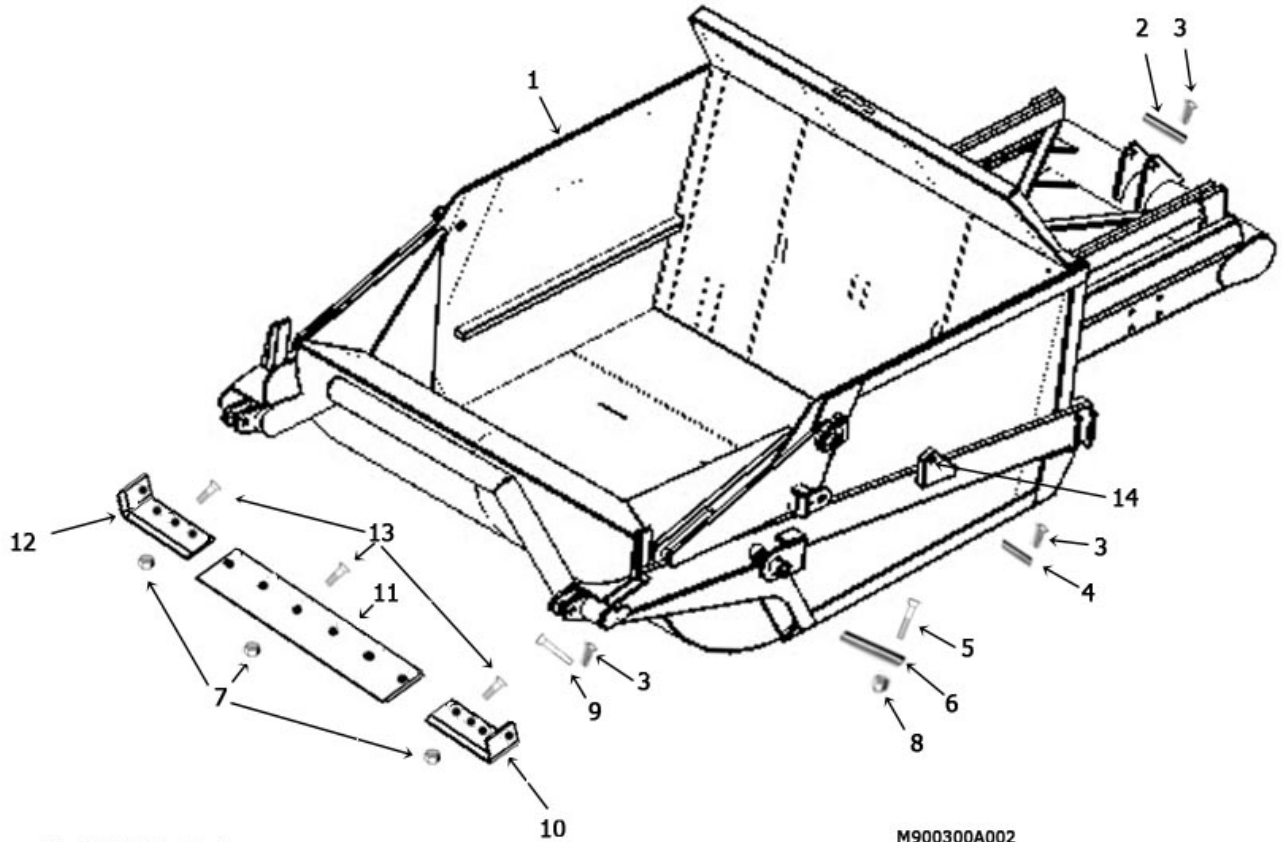

M900300A002

Blade Bolts Required:		
		Qty
A8030	PB8P-NC-063-0200	(6)
A8029A	PB8P-NC-063-0200	(4)
A8031A	PB8P-NC-063-0200	(4)

KEY	PART	DESCRIPTION	REMARKS
1	A9055	Bowl and Frame 900-950	
2	A8062	Pin, 1-1/4" x 7"	
3	AFP-00002	Cotter Pin, 3/16" X 1 3/4"	
4	A1217	Pin, 1" x 3-1/2"	
5	AFB-00054	Bolt: 1/2" NC X 3 1/2"	
6	A8056	Pin, 1-3/4" x 7-3/4"	
7	7530	Nut: 5/8" NC	
8	AFN-00011	Nut: 1/2" NC	
9	A10168	Pin: 1/1/8" X 4 1/4"	
10	A8031A	Left Cutting Edge	



PHONE : 715-682-4622 Fax: 715-682-9717

ASHLAND SCRAPERS

Bowl & Frame Assembly (900-950)

KEY	PART	DESCRIPTION	REMARKS
11	A8030	Center Cutting Edge	
12	A8029A	Right Cutting Edge	
13	PB8P-NC-063-0200	Plow Bolt, 5/8" x 2"	
14	14505	Grease Fitting, 1/8 UPT	

Push Off Assembly (900-950)

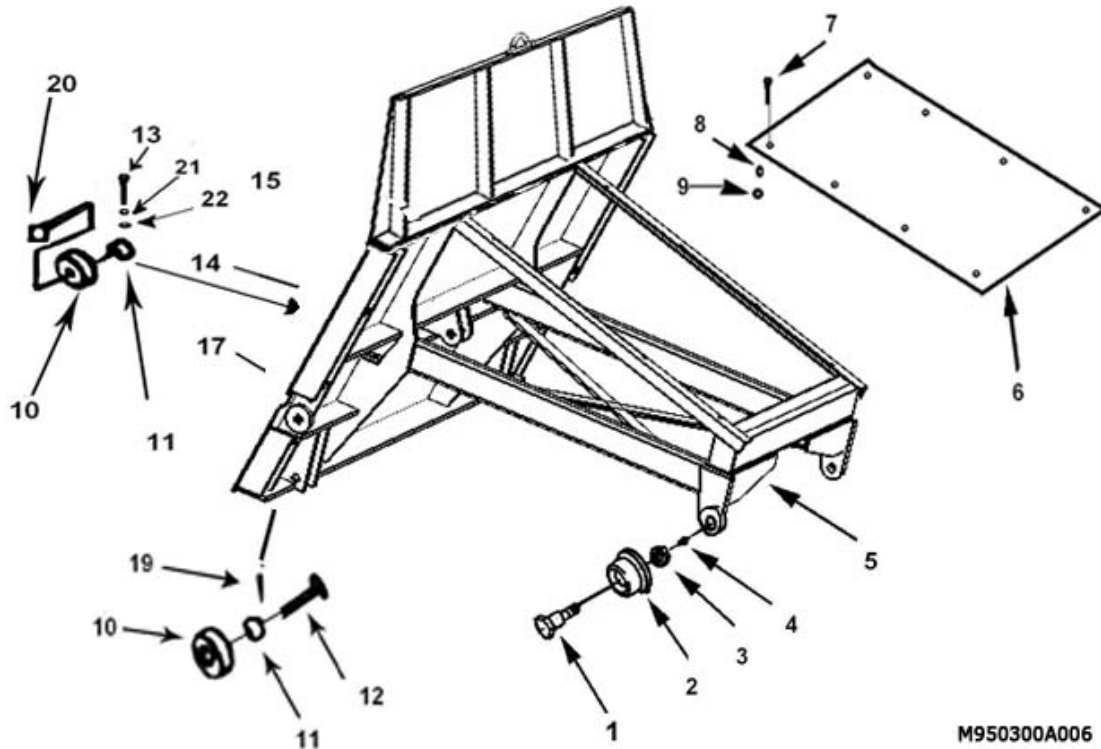

M950300A006

KEY	PART	DESCRIPTION	REMARKS
1	A10008	Shoulder Pin, 1 5/8" to 1 1/4" with zerk in threaded end	
2	A123306	Roller, gate rear with flange type	
3	AFN-00024	Jam Nut, 1 1/4" NF	
4	14505	Grease Fitting, 1/8" NPT straight	
5	A9056	Push Off Gate	
6	A9058	Dirt Shield	
7	AFB-00015	Bolt: 1/2" NC X 1 1/2"	
8	8100	Lockwasher, 1/2"	
9	AFN-00011	Nut, 1/2" NC	
10	A10164	Roller: 4 1/4 OD x 1 3/4 ID	
11	A10163	Bushing: 1 3/4" OD X 1 1/4" ID	
12	A6007A	Pin: 1 1/4" X 4 1/8" Lg.	
13	7036	Bolt: 1/2 NC X 2 Gr 8	
14	A125020	32" Greaseline	
15	A123323-40	Double Hole Tab	
16	A125026	Bulkhead Nut	



PHONE : 715-682-4622 Fax: 715-682-9717

ASHLAND SCRAPERS

Push Off Assembly (900-950)

KEY	PART	DESCRIPTION	REMARKS
17	A125021	54" Greaseline	
18	A125019	Grease Fitting 1/4 - 28: 54 L	
19	AFP-00001	Cotter Pin: 1/4 X 3 Lg.	
20	A123288	Pin: 1 1/4 X 3 1/4 Tab Head	
21	8100	1/2" Lockwasher	
22	7500	Nut: 1/2 NC	

Pole & Axle Assembly (900-950)

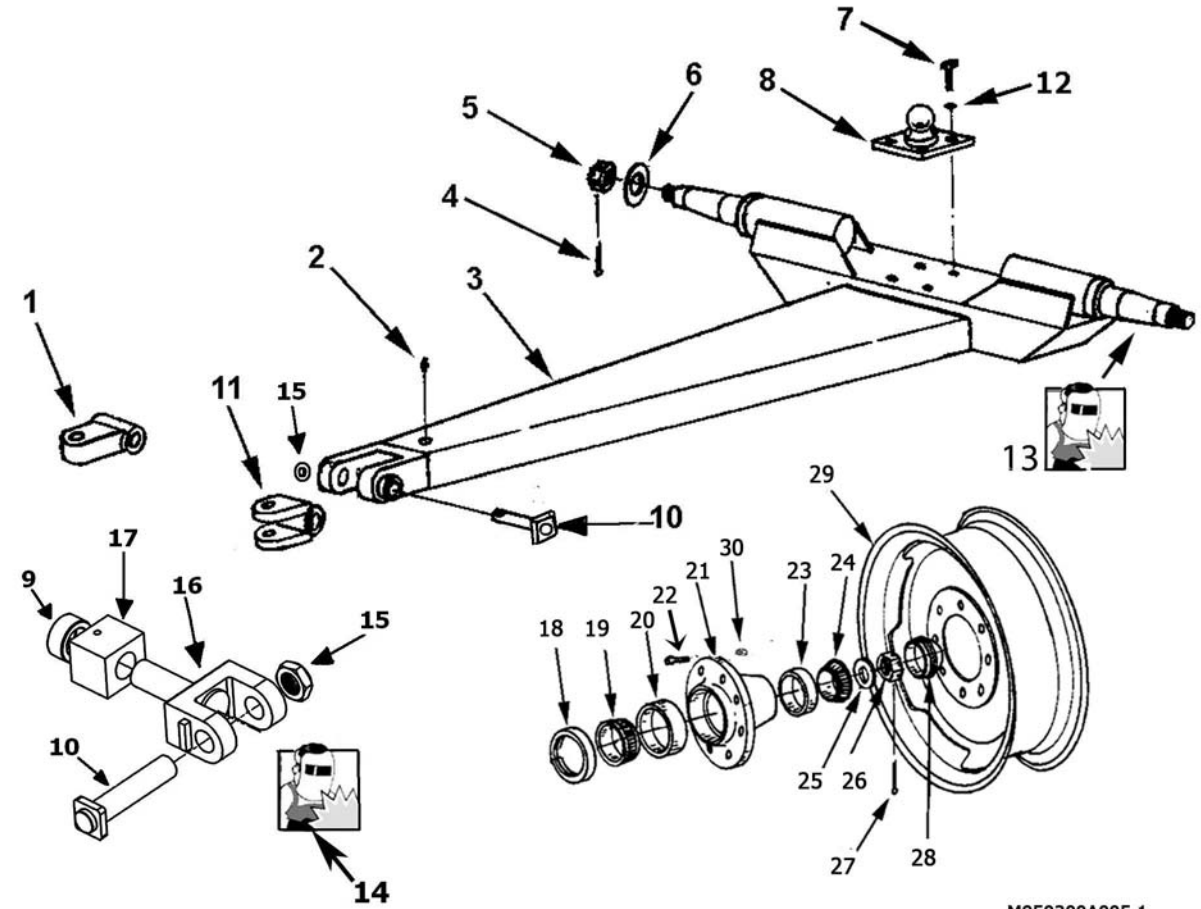

M950300A005.1

KEY	PART	DESCRIPTION	SN 950	REMARKS
1	A10033A	Single Lip Hitch		
2	14505	Grease Fitting, 1/8 NPT		
3	A9059	Pole		
4	AFP-00002	Cotter Pin, 3/16" X 1 3/4"		
5	AFN-00010	Nut, castellated, 1 1/4" NF		
6	A8027	Washer, special, 1 1/4" flat		
7	AFB-00005	Bolt, 3/4" NC X 2 1/2" L		
8	A40006	Ball Swivel		
9	A030568-01	Hitch Collar		
10	600053	Pin, Swivel Hitch		
11	A10033	Double Lip Clevis Hitch		
12	AFW-00002	Lockwasher, 3/4"		
13	A9062	Weld, Spindle Blank		
14	A031076W	Yoke Hitch Rebuild Kit (Containing items: 9,10,15,16,17)		
15	500433	Nut: Jam		
16	A030168-3A	Swivel Yoke Assembly		
17	A030568-1	Swivel Block		
18	A8020	Grease Seal (CR 35062)		
19	A9061	Bearing Cone, inner		
20	A8022	Bearing Cup, inner		
21	A125319	Hub	22410-XXXXX	

ASHLAND SCRAPERS

Pole & Axle Assembly (900-950)

KEY	PART	DESCRIPTION	SN 950	REMARKS
	A8023	Hub	XXXXX-22409	
22	A125320	Wheel Stud	22410-XXXXX	
	A4519	Wheel Bolt, 9/16" NF	XXXXX-22409	
23	A8024	Bearing Cup, outer		
24	A8025	Bearing Cone, outer		
25	A8027	Spindle washer, special		
26	AFN-00005	Spindle Nut		
27	AFP-00002	Cotter Pin, 3/16" X 1 3/4"		
28	A8026	Hub Cap		
29	A6022A	Wheel, 16.1 X 11" DC		
30	A125321	Nut: Wheel 5/8"	22410-XXXXX	

ASHLAND SCRAPERS

Wheel Assembly (900-950)

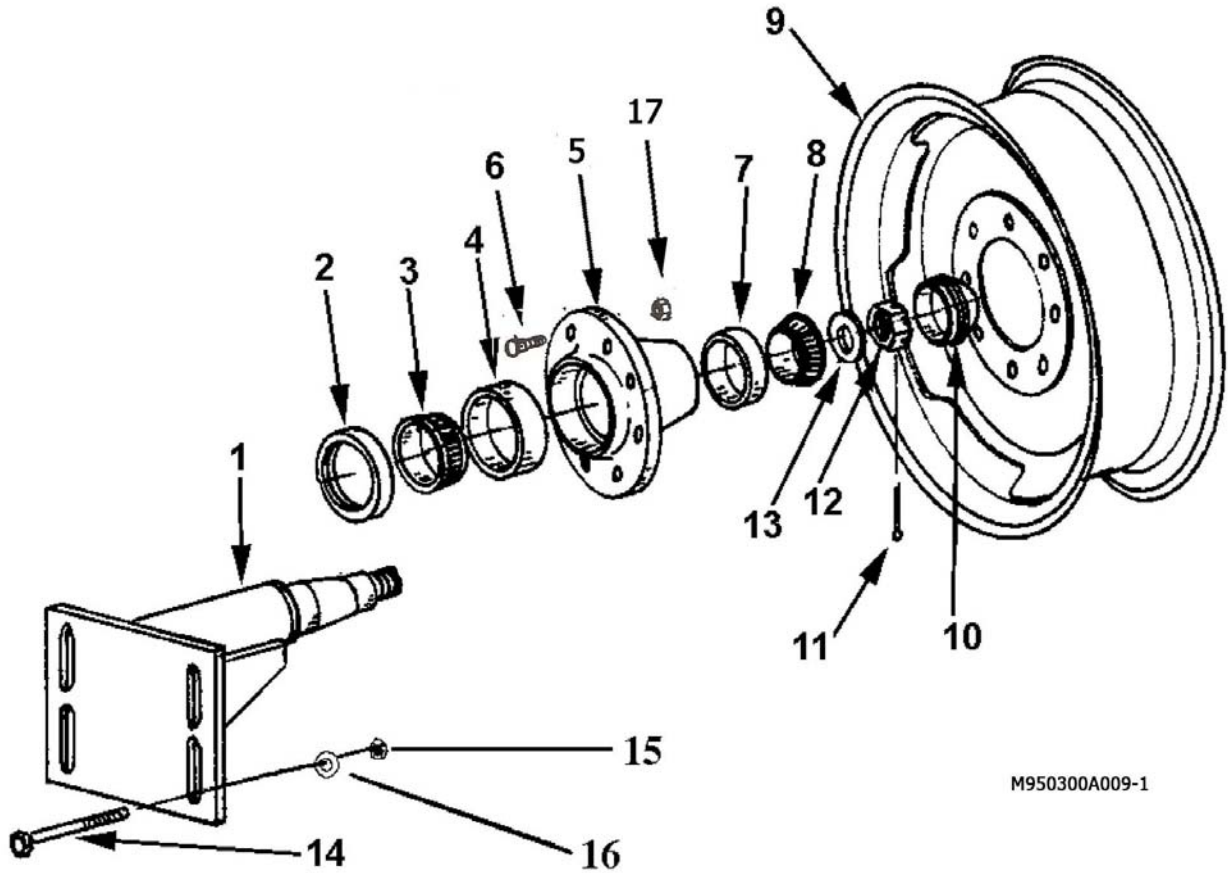

M950300A009-1

KEY	PART	DESCRIPTION	SN 950	REMARKS
1	A9060	Spindle, Rear with flange base plate		
2	A8020	Grease Seal (CR 35062)		
3	A9061	Bearing Cone, inner		
4	A8022	Bearing Cup, inner		
5	A125319	Hub	22410-XXXXX	
	A8023	Hub	XXXXX-22409	Obsolete
6	A125320	Stud: Wheel 5/8"	22410-XXXXX	Pressed-in
6	A4519	Wheel Bolt, 9/16" NF	XXXXX-22409	
7	A8024	Bearing Cup, outer		
8	A8025	Bearing Cone, outer		
9	A6022A	Front Wheel 16.1 X 11" DC		
9	A6023	Rear Wheel 24" x 15"		
10	A8026	Hub Cap		
11	AFP-00002	Cotter Pin, 3/16" x 1-3/4"		
12	AFN-00005	Spindle Nut		
13	A8027	Spindle washer, special		
14	AFP-00001	Bolt, 1" NC x 6-1/2" long		
15	AFN-00012	Nut, 1" NC		
16	AFW-00001	Flat Washer, 1"		
17	A125321	Nut: Wheel 5/8"	22410-XXXXX	

Lift Cylinder (#A416H118) 4" X 16"

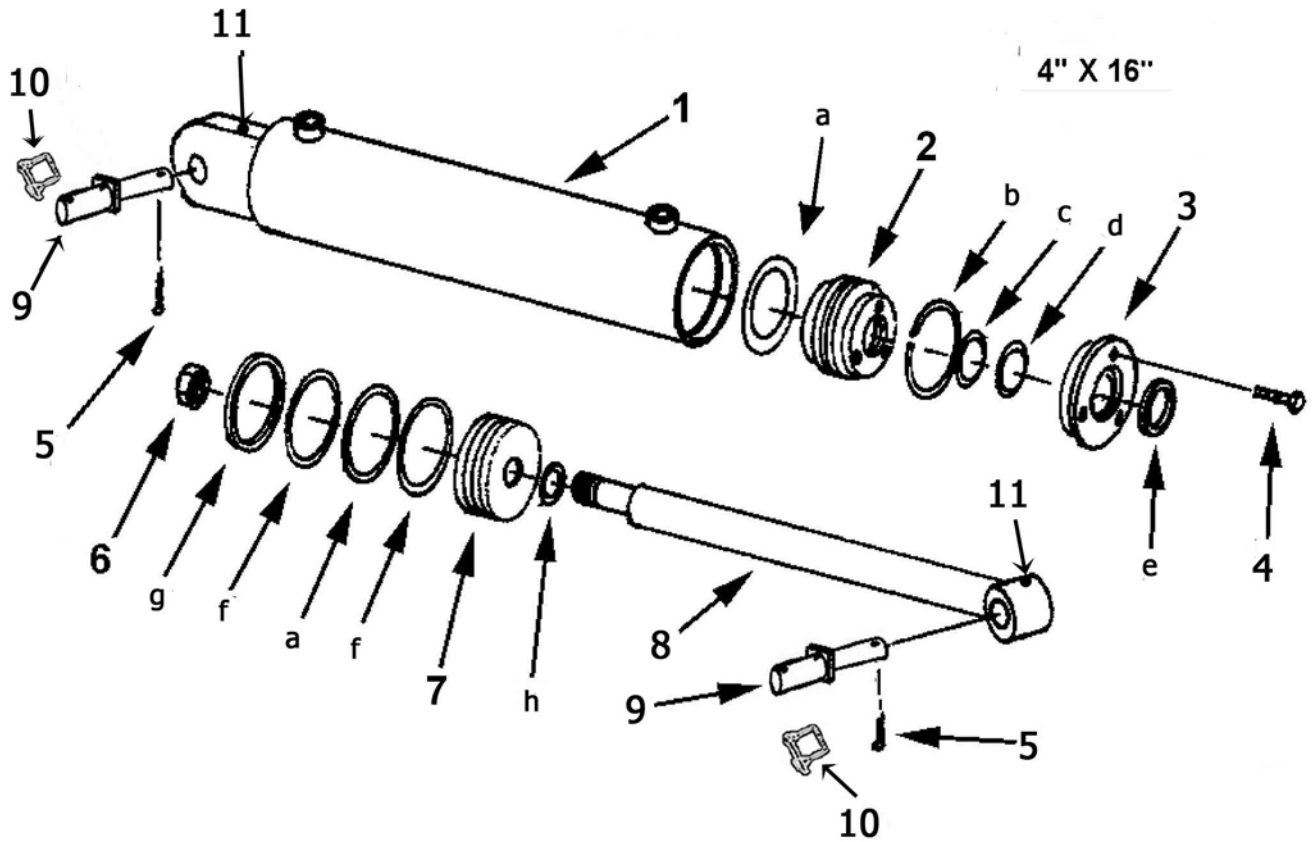

M950350P001-2

KEY	PART	DESCRIPTION	SN 950	REMARKS
	A416H118	LIFT CYLINDER 4" X 16"		
1	A45H04	Barrel Assembly		
2	A300H11	Head Gland		
3	A300H13	Head Cap		
4	A22H18	Capscrew, 1/4" x 1"		
5	AFP-00002	Cotter Pin, 3/16" X 1 3/4"	22782-XXXXX	
	AFP-00003	Cotter Pin, 3/16" X 1 1/2"	XXXXX-22781	
6	A300H03	Piston Nut		
7	A300H07	Piston, 4"		
8	A45H03-118	Shaft, 1-1/2" diameter		
9	A123215-43	Pin: 1 1/8 X 6 3/8" w/Sq. Head	22782-XXXXX	
	A10168	Pin, 1 1/8" X 4 1/4" Rod End	XXXXX-22781	
	A45003	Pin, 1-1/8" x 3-1/4" Barrel End	XXXXX-22781	
10	A125006	Snap Ring	22782-XXXXX	
11	14505	Grease Fitting		
	A300H14B	Cylinder Seal Kit ,containing: (a-h)		
a		O-ring, 4" OD x 3/16"		
b		Retainer Ring		
c		O-Ring 1 1/2" ID X 1/8"		
d		Backup Washer		
e		Wiper Seal		
f		Backup Washer, 4" OD		



PHONE : 715-682-4622 Fax: 715-682-9717

ASHLAND SCRAPERS

Lift Cylinder (#A416H118) 4" X 16"

KEY	PART	DESCRIPTION	SN 950	REMARKS
g		Cast Iron Ring		
h		Backup Ring 1" OD		

ASHLAND SCRAPERS

Apron Cylinder (#A125050) 4" X 13"

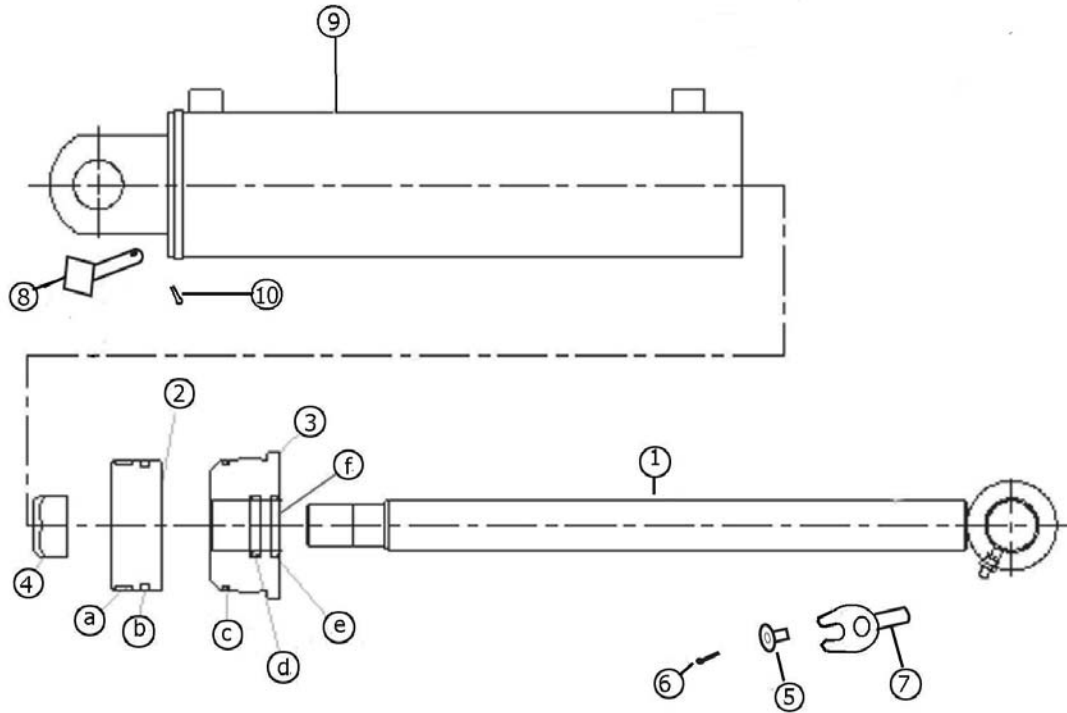

A350P004

KEY	PART	DESCRIPTION	SN 950	REMARKS
	A125050	APRON CYLINDER 4" X 13"	22395-XXXXX	
1	A125050-01	Rod 1-3/4" with welded eye		
2	A125050-02	Piston		
3	A125050-03	Gland, Threaded		
4	A125050-04	Lock Nut, 1-1/8" NF		
5	A123351	Pin Keeper Bushing		
6	AFB-00019	1/2" x 1 1/2" Gr 8 Bolt		
7	A123362	Pin: Cyl. Rod End 1 1/2 X 4 1/2 w/ Tab		
8	A123363	Pin: Cyl. Base End 1 1/2 X 4 1/8"		
9	A125050-06	Cylinder Barrel		
10	8602	Cotter Pin: 1/4 X 2		
	A125050-05	Seal Kit Containing (a-f)		
a		Nylon Wear Ring		
b		FSP Seal		
c		O-Ring		
d		Backup Washer		
e		Hallite Rod Seal		
f		Snap in Rod Wiper		

ASHLAND SCRAPERS

Push Off Cylinder (#A125111) 4" x 50"

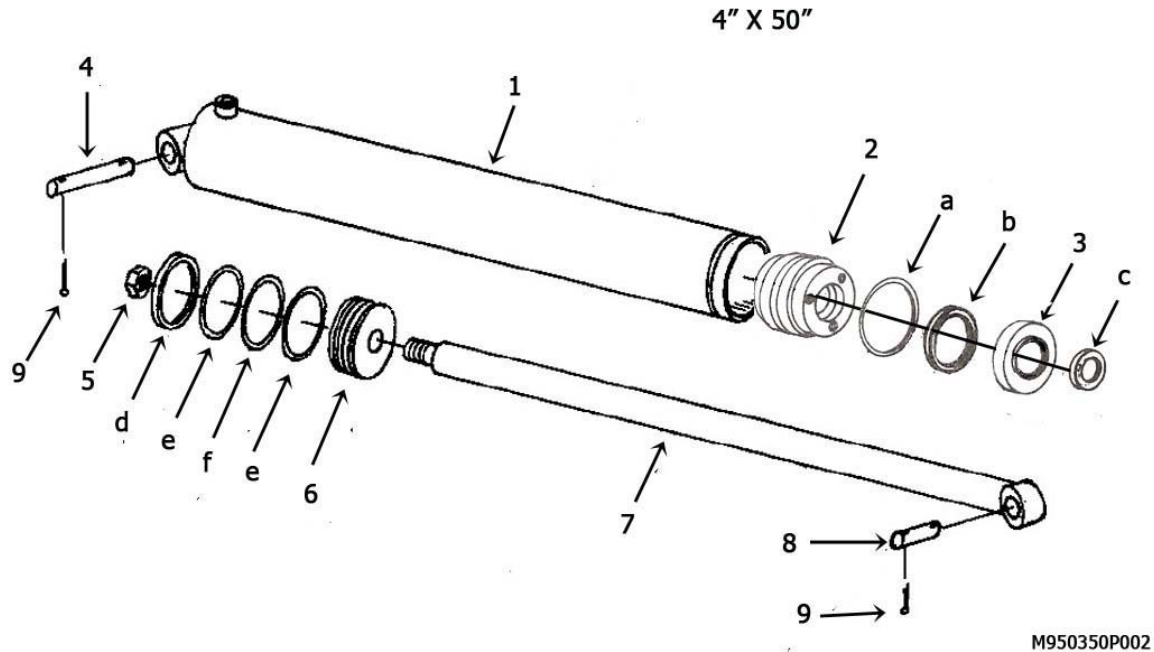

M950350P002

KEY	PART	DESCRIPTION	SN 950	REMARKS
	A125111	PUSH OFF CYLINDER 4" X 50"	21226-XXXXX	
1	A123424	Barrel Assembly		
2	A123425	Head Gland		
3	A123426	Collar		
4	A8062	Pin, 1-1/4" x 7"		
5	A400H17	Piston Nut, 1-1/4" NF		
6	A80H27	Piston		
7	A90H26	Rod Assembly		
8	A8061	Pin, 1-1/4" x 4-3/4"		
9	8602	Cotter Pin, 1/4" x 2"		
	A80H30	Seal Kit Containing (a-f)		
a		O-ring, 4" OD x 1/8"		
b		Seal: U-Cup		
c		Wiper Seal, 2" ID		
d		Cast Iron Ring, 4" OD		
e		Backup Washer, 4" OD		
f		O-ring, 4" OD x 3/16"		

ASHLAND SCRAPERS

Hydraulic Manifold (#A125174)

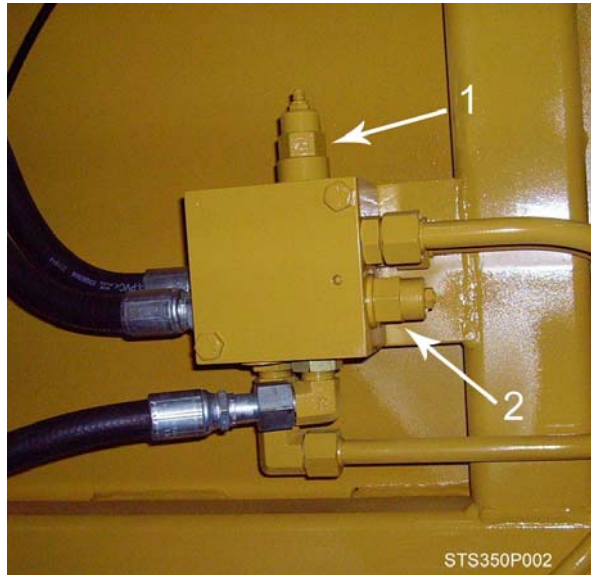

KEY	PART	DESCRIPTION	REMARKS
1	A125162-02	PUSHOFF SEQUENCE CARTRIDGE	
2	A125162-01	COUNTER BALANCE CARTRIDGE	

SETTING THE APRON AND PUSHOFF VALVE

The manifold block containing the pushoff sequence valve cartridge and apron sequence valve cartridge is used to control two hydraulic circuits with one hydraulic remote. When the tractor hydraulic remote is activated, oil flows first to the apron cylinders until they are fully extended. Once the cylinders are fully extended, the apron circuits' hydraulic pressure begins to increase. Once the pressure threshold is surpassed (which is adjustable. See adjustment section), the sequence valve diverts the oil flow to the pushoff's hydraulic circuit. Once the push off is completely extended the operator then reverses the tractors hydraulic remote. The counterbalance valve will hold the apron open until the push off is fully retracted. The Apron sequence valve then opens and allows the apron to close.

Setting the valves:

STEP 1 PUSHOFF SEQUENCE VALVE

Loosen the lock nut (9/16") on the sequence valve cartridge. Turn the setscrew (4mm) clockwise until the front apron rises before the push-off begins to advance. (Earthmover should be empty) Turn the adjustment screw an additional 1/4 turn clockwise and tighten jam nut.

STEP 2 COUNTER BALANCE VALVE

Loosen the lock nut (9/16") on the counterbalance valve cartridge. Turn the setscrew (4mm) counter-clockwise until the apron holds in a raised position while rear gate is being retracted. Turn adjustment screw an additional 1/4 turn, tighten jam nut. DO NOT tighten adjusting screw more than necessary.

ASHLAND SCRAPERS

Hydraulic Valve Ports Assembly

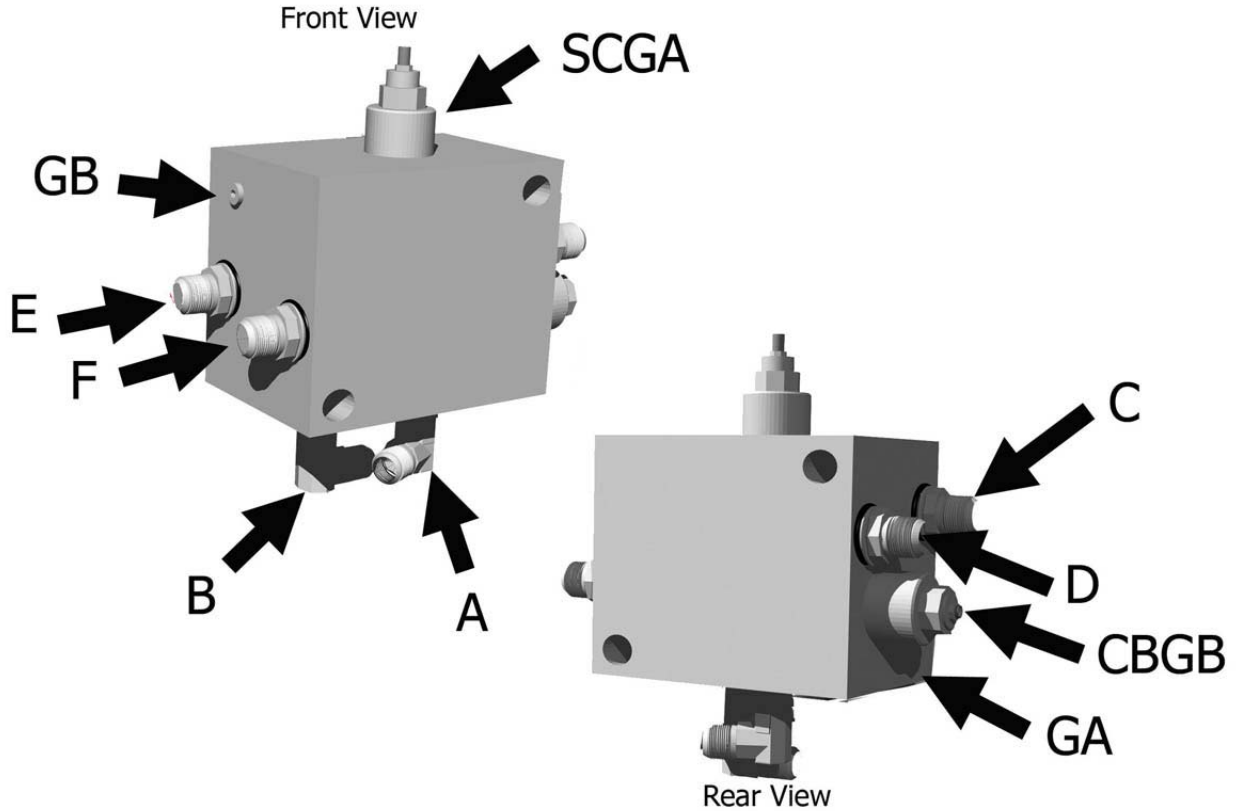

The lettering for the port locations are stamped on the block

A350P010

KEY	PART	DESCRIPTION	REMARKS
A		Supply Line	
B		Pushoff Cyl. (Rod End)-Apron Cyl., Right side (Rod end)-Supply Line	
C		Pushoff Cylinder, (Base End)	
D		Apron Cylinder, Right side, (Base End)	
E		Apron Cylinder, Left side, (Rod End)	
F		Apron Cylinder, Left side, (Base End)	
CBGB		Counterbalance Valve, adjustable	
SCGA		Sequence Valve, adjustable	
GA		Pressure test port	
GB		Pressure test port	

ASHLAND SCRAPERS

Hydraulic Valve Seals

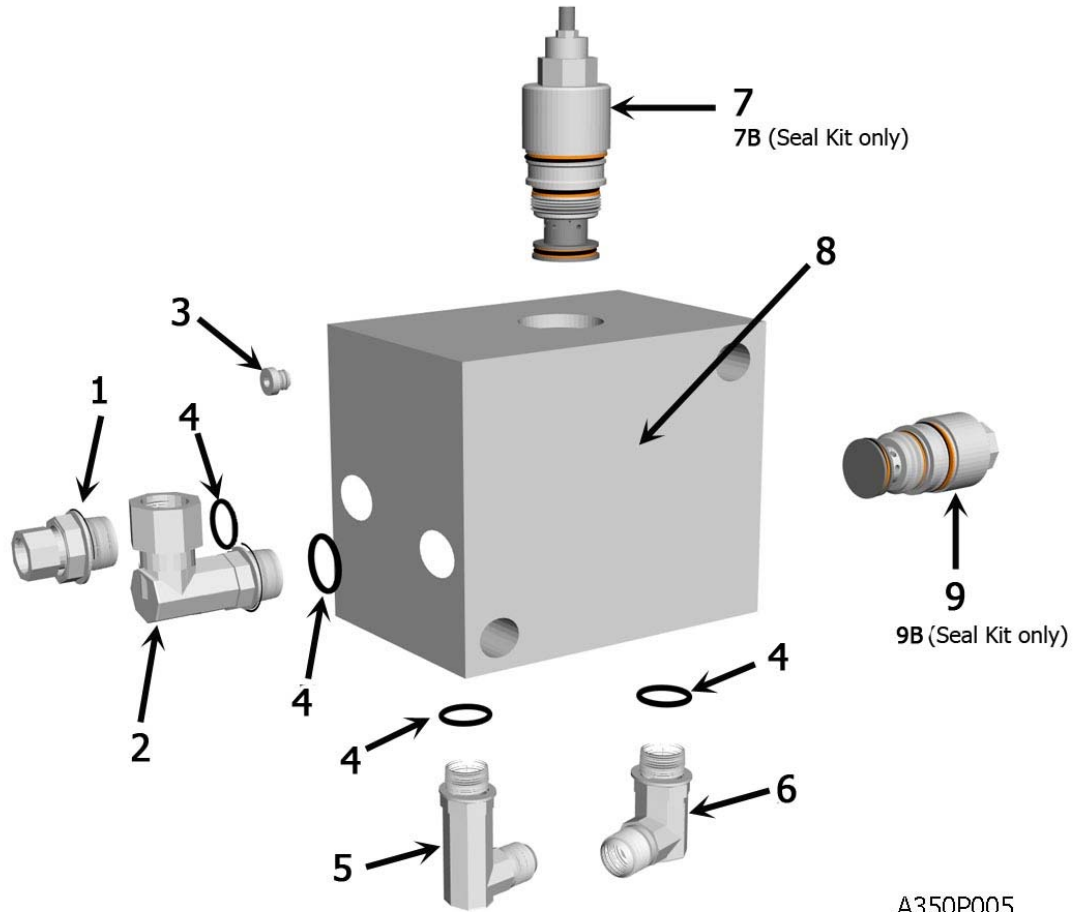

A350P005

KEY	PART	DESCRIPTION	REMARKS
1	AHA-00043	Adapter: Str. Sw. 1 1/16 M ORB X 1/2 FP	
2	AHA-00048	Adapter: 90 Deg. Swiv. 1 1/6 M ORB X 1/2 FP	
3	AHA-00046	6 ORB Plug	
4	AHS-00153	O-Ring for 12 M ORB Fitting	
5	AHA-00047	Adapter: 90 Deg. XL 3/4 MJX 1 1/6 M ORB	
6	AHA-00044	Adapter: 90 Deg. 3/4 MJ X 1 1/6 M ORB	
7	A125162-02	Valve: Sequence Cartridge for Ver. III & IV	
8	A125174	Valve: Manifold Block IV Body	
9	A125162-01	Valve: Counterbalance Cartridge for Ver. III & IV	
9B	A125162-01 KIT	Seal Kit for A125162-01 Valve Cartridge	
7B	A125162-02 KIT	Seal Kit for A125162-02 Valve Cartridge	

ASHLAND SCRAPERS

Hydraulic Plumbing Front (I-950)

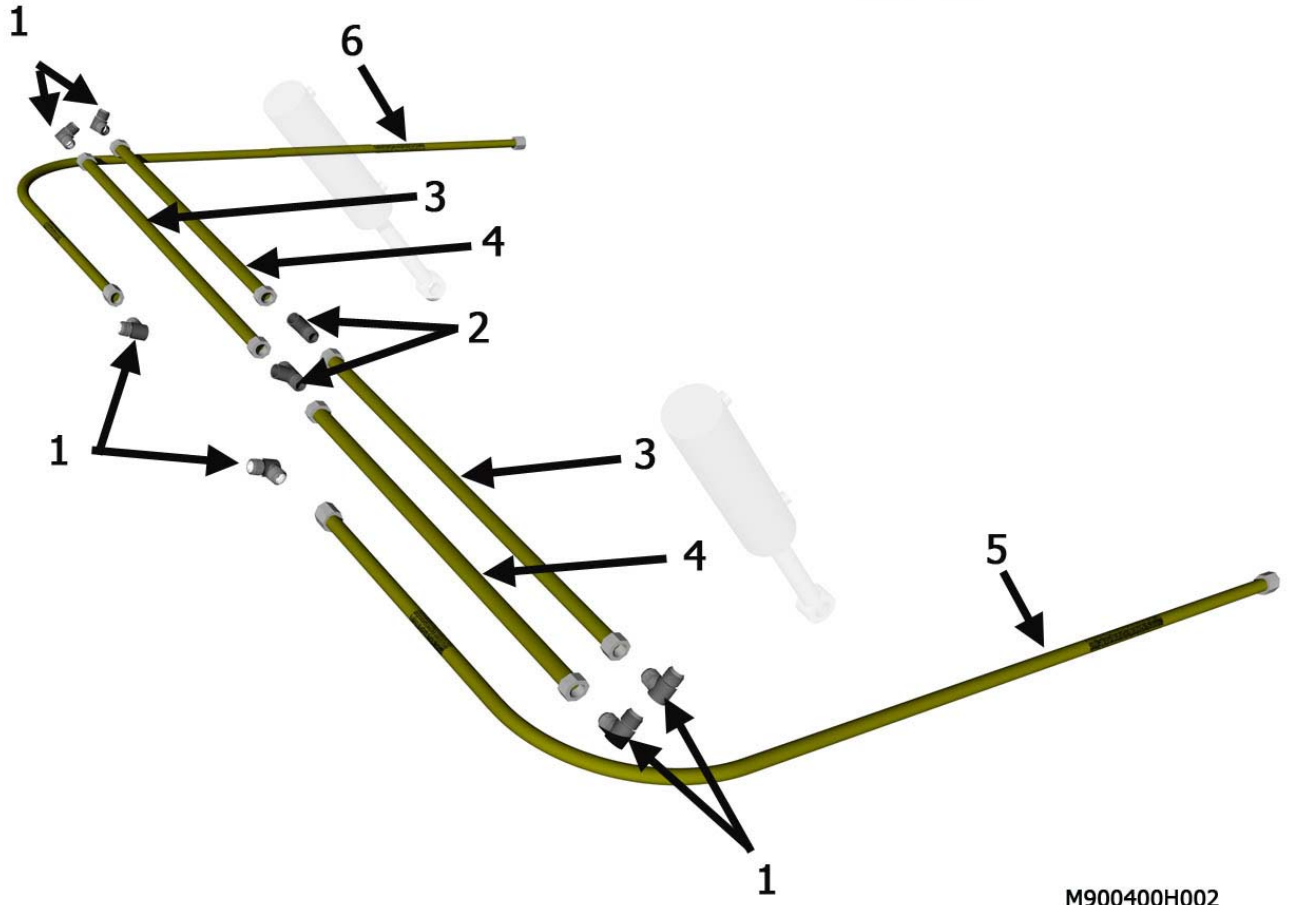

M900400H002

KEY	PART	DESCRIPTION	REMARKS
1	AHA-00019	Adapter: 90 Deg. 3/4 MJ X 3/4 MJ	
2	AHA-00022	Adapter: T 3/4 MJ X 3/4 MJ X 3/4 MJ	
3	A125063	Tube Assembly: 3/4" X 32 3/4"	
4	A125064	Tube Assembly: 3/4" X 30 1/2"	
5	A125272	Tube Assembly: I-900 Left Front Arm	
6	A125273	Tube Assembly: I-900 Right Front Arm	

ASHLAND SCRAPERS

Hydraulic Plumbing Rear (I-950)

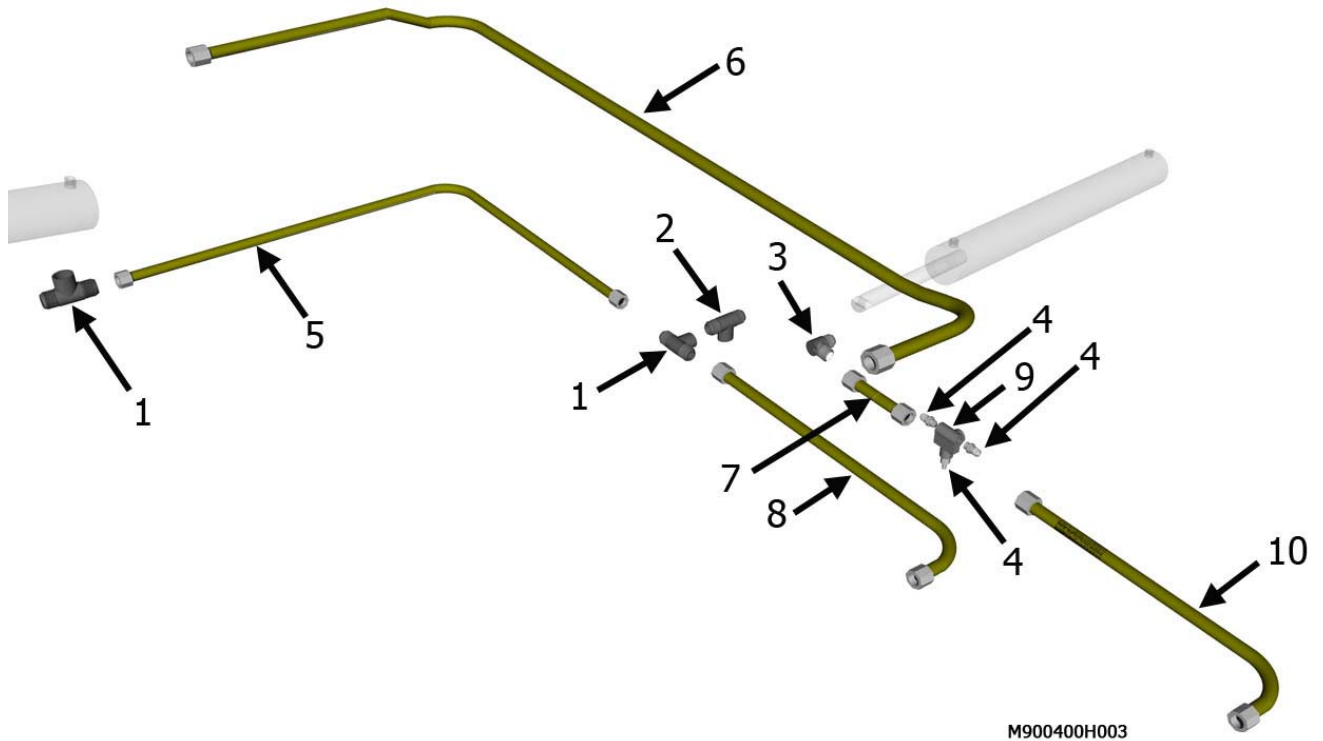

KEY	PART	DESCRIPTION	REMARKS
1	AHA-00022	Adapter: T 3/4 MJ X 3/4 MJ X 3/4 MJ	
2	AHA-00049	Adapter: T 3/4 MJ X 3/4 MJ X 3/4 FJ Swiv.	
3	AHA-00019	Adapter: 90 Deg. 3/4 MJ X 3/4 MJ	
4	AHA-00006	Adapter: Str. 3/4 MJ X 3/4 MP	
5	A125060	Tube Assy: 3/4" X 77 3/4" W/ 12 JIC Nuts and Sleeve	
6	A125182	Tube Assy:	
7	A155-H21	Tube Assy:	
8	A125183	Tube Assy:	
9	AHV-00001	Valve: Pressure Relief (in-line)	
10	A125184	Tube Assy:	

ASHLAND SCRAPERS

Parts - Hydraulic Clamps

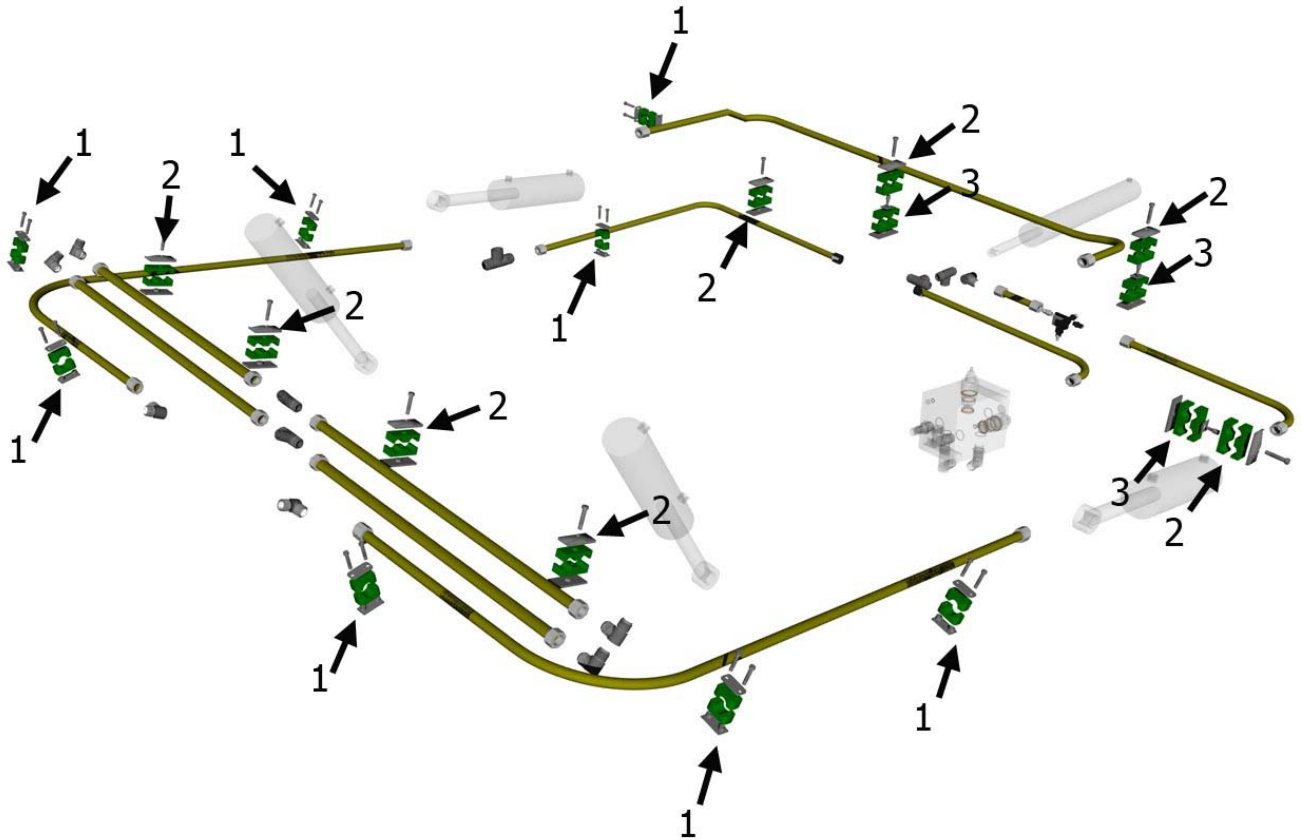

M900400H005

KEY	PART	DESCRIPTION	REMARKS
1	AHL-00001	Clamp: Hydraulic Line - 1 Tube	
2	AHL-00002	Clamp: Hydraulic Line - 2 Tube Ass'y	
3	AHL-00022	Clamp: Ass'y Hyd. Line - 1 Tube	

Hydraulic Hoses (I-950))

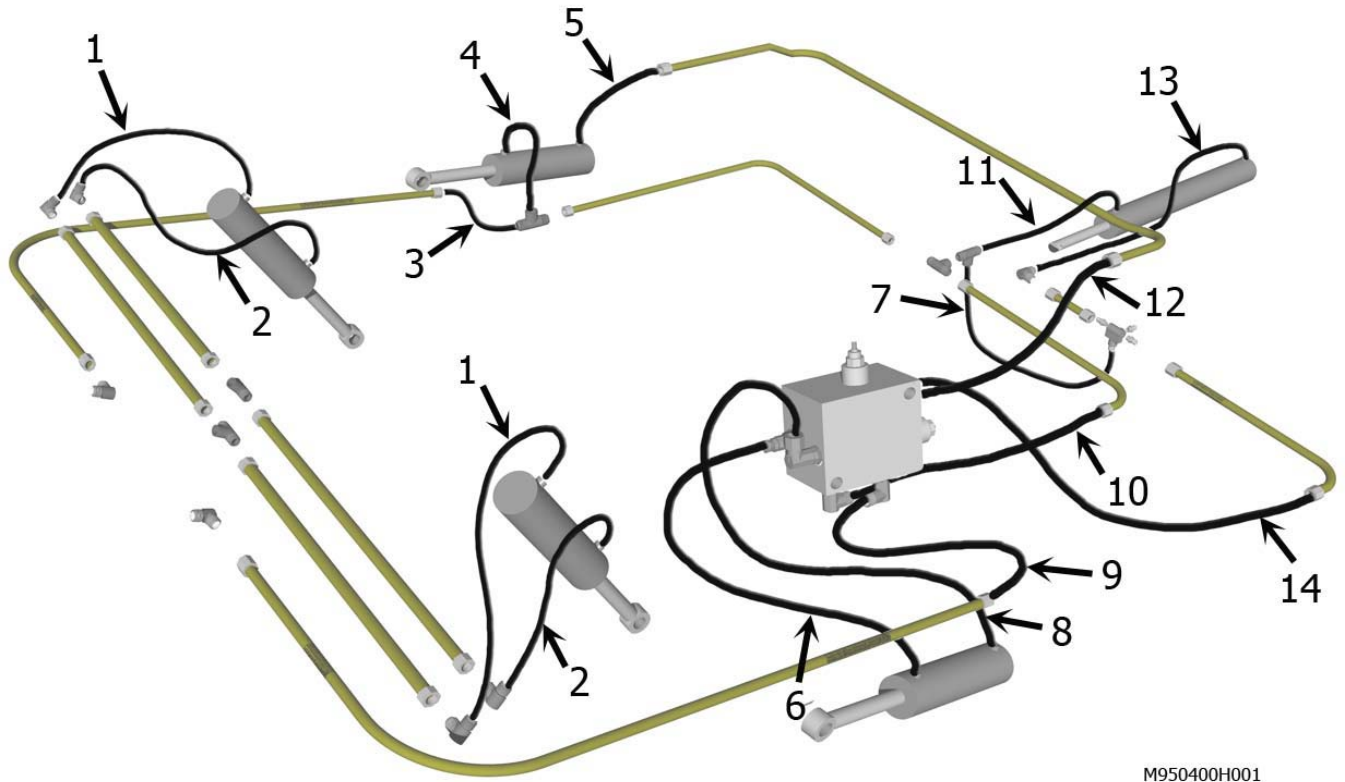

M950400H001

KEY	PART	DESCRIPTION	REMARKS
1	A900-H12	Hose Assembly: 1/2" x 19-1/2" Lift Cyl. Base End Port	
2	A900-H11	Hose Assembly: 1/2" x 25" Lift Cyl. Rod End Port	
3	A900-H10	Hose Assembly: 1/2" X 42" R. Tube - Front Arm	
4	A900-H09	Hose Assembly: 1/2" x 25-1/2" R. Apr. Cyl. Rod End Port	
5	A900-H08	Hose Assembly: 1/2" x 18" R.Apr.Cyl. Base End Port	
6	A900-H21	Hose Assembly: 1/2" X 23" L. Apr. Cyl. Rear Tube	
7	A900-H05	Hose Assembly: 1/2" X 17" PRV-Tube @ Bowl Rear	
8	A900-H20	Hose Assembly: 1/2" X 16" L. Apron Cyl. Top Tube	
9	A900-H26	Hose Assembly: 1/2" X 48" to Valve Block	
10	A900-H25	Hose Assembly: 1/2" X 20" Valve Port to Tube @ Bowl L. Rear	
11	A900-H06	Hose Assembly: 1/2" x 16" Tube - Push Off Cyl. Rod End	
12	A900-H22	Hose Assembly: 1/2" X 20" Valve Port to D to Tube @ Bowl Rear	
13	A900-H24	Hose Assembly: 1/2" X 50" P.O. Cyl. Base End Port	



PHONE : 715-682-4622 Fax: 715-682-9717

ASHLAND SCRAPERS

Hydraulic Hoses (I-950))

14 A900-H23

Hose Assembly: 1/2" X 21" Valve Port to C to Tube @ Bowl
L.Rear

ASHLAND SCRAPERS
Decals Illustration (I-950)

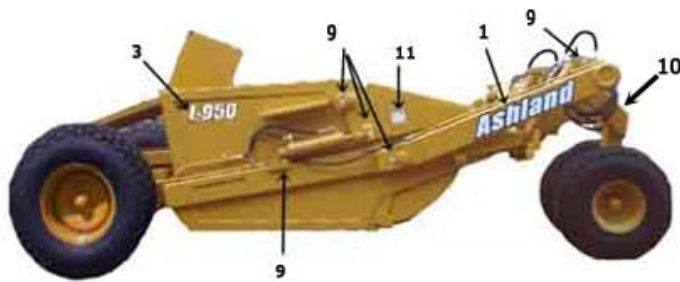
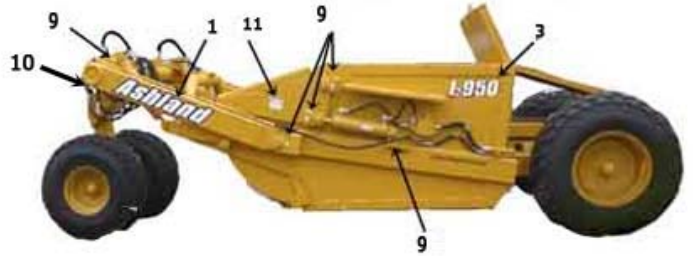

↑
1



↑
2



↑
3



↑
9



↑
11 11



↑
10

M950100SD002



PHONE : 715-682-4622 Fax: 715-682-9717

ASHLAND SCRAPERS

Decals

KEY	PART	DESCRIPTION	REMARKS
1	ADS-00001	Large Ashland	
2	ADS-00002	Small Ashland	
3	ADS-00037	I-950	
9	ADS-00019	Grease	
10	750464	High Pressure Fluid Hazard	
11	ADS-00011	Pinch Point	

ASHLAND SCRAPERS

Maintenance Check list

1. Grease all zerks.
 - a) Every 8 hours of operation.
 - b) See Lubrication Points section on next page.

2. Greasing the hubs.
 - a) Re-pack wheel bearings after 300 hrs of operation.
 - b) Completely clean grease out of hub and bearings every 1200 hours of operation.

3. Check tire pressure.
 - a) 20.5 - 25, 12-ply tire requires a tire pressure of 35-40 psi on a rear tire, 40-50 on a front tire.

4. Check all pins for signs of wear.
 - a) Daily

5. Check wheel lug nut torque.
 - a) After first 2 hours of operation.
 - b) Recheck daily for next 2 weeks.
 - c) Tighten wheel lug nuts in a star pattern.
 - d) Torque wheel lug nuts to 120 to 130 ft-lbs.

6. Check and retighten all bolts.
 - a) After initial 10 hours of use.
 - b) Again after 50 hours of use.
 - c) See Torque Specifications on next page.

7. Inspect cutting edges.
 - a) Daily
 - b) Replace cutting edges when center blade has been worn to approximately 6" and side edges worn to approximately 4".



CAUTION! Failure to replace worn cutting edges may result in unnecessary wear to the earthmover sides and floor.

Note: Please specify left or right "L" shaped cutting edges when ordering replacements. Left or right side parts are determined by viewing from rear of the scraper.

ASHLAND SCRAPERS

Torque Specifications

TORQUE SPECIFICATIONS

<i>Bolt</i>	<i>Torque</i>		
<i>Diameter</i>	<i>Ft-lbs</i>		
<i>1/4</i>	<i>12</i>		
<i>5/16"</i>	<i>25</i>		
<i>3/8"</i>	<i>45</i>		
<i>7/16"</i>	<i>70</i>		
<i>1/2"</i>	<i>110</i>		
<i>9/16"</i>	<i>150</i>		
<i>5/8"</i>	<i>220</i>		
<i>3/4"</i>	<i>380</i>		
<i>7/8"</i>	<i>600</i>		
<i>1"</i>	<i>900</i>		
<i>1-1/8"</i>	<i>1280</i>		
<i>Lug Nuts</i>	<i>85-100 /9 yd</i>	<i>450- 11/13 yd</i>	<i>750-15 yd & up</i>

LUBRICATION

1. Grease all zerks every 8 hrs of operation with high quality, general-purpose grease.
 - a) Grease until grease flows from around pin.

Lubrication Points (see III.)

1. Hitch – Horizontal and vertical pins.
2. Lift Cylinders – Rod end & Trunion; Both left & right sides.
3. Front Arm Pivot Joint – Both left & right sides.
4. Apron Cylinders – Rod clevis pin; Both left & right sides.
5. Apron Pivot Pin – Both left & right sides.
6. Hold-down Rollers – Both left & right sides.
7. Floor Rollers – Both left & right sides.
8. Tapered Rollers – Both left & right sides.

ASHLAND SCRAPERS

Tire Service



The task of servicing tires and wheels can be extremely dangerous and should be performed by trained personnel only, using the correct tools and following specific procedures. Do not attempt to mount, demount or inflate a tire if you do not have the proper equipment and experience to perform the job. Call a qualified repair service to inspect the assembly and make necessary repairs. Failure to heed warnings could lead to serious injury or death.

Visually inspect tires and wheels daily. Carefully inspect any rim and tire assembly that has been run underinflated or flat before reinflating the tire to make sure there is no damage to either the rim or tire.

- ALWAYS wear personal protection equipment such as gloves, footwear, eye protection, hearing protection and head gear when servicing tire and wheel components.
- DO NOT operate with damaged rims, tire cuts or bubbles, missing lug bolts or nuts or damaged rims.
- ALWAYS maintain the correct tire pressure. NEVER exceed recommended tire inflation pressure.
- INSPECT any rim and tire assembly that has been run flat or severely underinflated before reinflating the tire. Damage to the rim and tire may have developed.
- NEVER inflate a tire that has lost air pressure or has been run flat without determining and correcting the problem.
- NEVER try to repair wheel, rim, or tire components parts. Parts that are cracked, worn, pitted with corrosion, or damaged must be discarded, and replaced with good parts.
- ALWAYS use approved tire and rim combinations for the model scraper that you have and verify that part numbers of components are correctly matched for the assembly.
- ALWAYS exhaust all air from the tire prior to demounting.
- ALWAYS place wheel and tire assemblies in restraining devices (safety cage) when inflating tires. Use a clip-on chuck and long extension hose to allow you to stand to the side of the tire and not in front of it.
- NEVER weld or cut on an inflated tire assembly. Welding heat can cause increased pressure which could result in tire explosion.
- ALWAYS use proper lifting techniques, and mechanized lifting aids to move heavy components and assemblies.
- NEVER leave a tire, wheel, or assembly unsecured in a vertical position.
- ALWAYS take care when moving tires and wheels that other people in the area are not endangered.

ASHLAND SCRAPERS

Pushing the Earthmover



PUSHING THE EARTHMOVER

This scraper was designed to be pushed when equipped with the optional push-bar. However, Ashland Industries, Inc. **STRONGLY** recommends using extreme caution when pushing the earthmover to prevent any unnecessary damage.

CAUTION! The earthmover must be pushed in a straight line with a maximum of a 100 hp dozer. Do not ram or jar the earthmover while pushing and push at a constant speed.

ASHLAND SCRAPERS

Troubleshooting

Introduction

With proper care and maintenance, your Ashland Scraper will give many years of reliable service. When a situation arises where the earthmover performance is not satisfactory, this section will give some pointers on finding and correcting the problem.

Grease zerk will not take grease.

1. Grease zerk plugged.
 - a) Remove and replace grease zerk.
 2. Pin is frozen.
 - a) Remove, clean, and inspect pin.
 - b) Replace pin if necessary.
 3. Bushing grease passage is not aligned with grease zerk.
 - a) Remove, clean, inspect, and realign bushing.
 - b) Replace bushing if necessary and realign.
-

Push-off rollers do not roll.

1. The rollers need lubrication.
 - a) Check zerk hole and grease.
 - b) Remove pin, clean, inspect, and replace if necessary.
 2. The roller bushing is worn out.
 - a) Remove roller assembly and replace bushing.
 - b) See parts manual.
-

Cylinders will not hold in preset position, i.e. the cylinder creeps.

1. Seals leaking internally.
 - a) Remove and replace seal kit.
-

Machine cuts unevenly.

1. Cutting edges worn unevenly.
 - a) Replace cutting edges.
 2. Improperly inflated tires.
 - a) Check air pressure in tires.
-



ASHLAND SCRAPERS

Warranty Statement

Limited Warranty Statement

Ashland Industries Inc. warrants each new product to be free from defects in material and workmanship. This warranty is applicable only for the normal service life expectancy of the product or components, not to exceed **six consecutive months** from the date of delivery of the new Ashland Industries product to the purchaser, or the date the product is first put into service via a rental agreement or other means, whichever occurs first.

The major components of swivel hitches used on Industrial series scrapers are warranted for three consecutive months from the date of delivery of the new Ashland Industries product to the purchaser, or the date the product is first put into service via a rental agreement or other means, whichever occurs first, except those components described below.

Genuine Ashland Industries Inc. replacement parts and components will be warranted for 30 days from date of purchase, or the remainder of the original equipment warranty period, whichever is longer.

Under no circumstances will it cover any merchandise or components thereof, which in the opinion of the company, has been subjected to misuse, unauthorized modification, alterations, an accident or if repairs have been made with parts other than those obtained through Ashland Industries Inc.

Ashland Industries Inc. in no way warrants Tires since their respective manufacturer warrants these items separately. Please call Ashland Industries Inc. to receive phone numbers of tire suppliers.

Ashland Industries Inc. in no way warrants wearable items such as cutting edges, front dolly wheel balls, socket halves, rollers, bushings, yoke hitch pins, hitch bushings, etc..

Our obligation under this warranty shall be limited to repairing or replacing, free of charge to the original purchaser, any part that, in our judgment, shall show evidence of such defect, provided further that such part shall be returned within 30 days from the date of failure to Ashland Industries Inc. routed through the dealer and distributor from whom the purchase was made, transportation charges prepaid. Upon warranty approval proper credits will be reimbursed for transportation.

This warranty shall not be interpreted to render Ashland Industries Inc. liable for injury or damages of any kind or nature to person or property. This warranty does not extend to the loss revenue, extra labor cost associated with downtime, substitute machinery, rental or for any other reason.

Except as set forth above, Ashland Industries Inc. shall have no obligation or liability of any kind on account of any of its equipment and shall not be liable for special or consequential damages. Ashland Industries Inc. make no other warranty, expressed or implied, and, specifically, Ashland Industries Inc. disclaims any implied warrant or merchantability or fitness for a particular purpose. Some states or provinces do not permit limitations or exclusions of implied warranties or incidental or consequential damages, so the limitations or exclusion in this warranty may not apply.

This warranty is subject to any existing conditions of supply which may direct affect our ability to obtain materials or manufacture replacement parts.

Ashland Industries Inc. reserves the right to make improvements in design or changes in specifications at any time, without incurring any obligation to owners of units previously sold.

No one is authorized to alter, Modify or enlarge this warranty nor the exclusion, limitations and reservations.

Ashland Industries Inc.
Warranty Department

Table of Contents

Alphabetized Listing

A	
Apron Assembly (950)	7
Apron Cylinder (#A125050) 4" X 13"	17
ASHLAND SCRAPERS	1-34
B	
Bowl & Frame Assembly (900-950)	8
D	
Decals	28
Decals Illustration (I-950)	27
G	
Gooseneck Frame Assembly	6
H	
How to Order Parts	2
Hydraulic Hoses (I-950))	25
Hydraulic Manifold (#A125174)	19
Hydraulic Plumbing Front (I-950)	22
Hydraulic Plumbing Rear (I-950)	23
Hydraulic Valve Ports Assembly	20
Hydraulic Valve Seals	21
L	
Lift Cylinder (#A416H118) 4" X 16"	15
M	
Maintenance Check list	29
O	
Operators and Maintenance	3
P	
Parts - Hydraulic Clamps	24
Pole & Axle Assembly (900-950)	12
Push Off Assembly (900-950)	10
Push Off Cylinder (#A125111) 4" x	18
Pushing the Earthmover	32
S	
Safety Guidelines	4
Serial Number	1
T	
Tire Service	31
Torque Specifications	30
Troubleshooting	33
W	
Warranty Statement	34
Wheel Assembly (900-950)	14
X	
XL Assembly	5