

# Ashland

## EARTHMOVERS



# I-900

# PARTS MANUAL

Ver. 0109- 22079



Ashland Industries Inc.  
1115 Rail Drive  
P.O. Box 717  
Ashland, WI. 54806  
Ph: 877-634-4622 Toll Free  
Ph: 715-682-4622  
Fx: 715-682-9717  
[www.ashlandind.com](http://www.ashlandind.com)

MEMBER



CONSTRUCTION INDUSTRY  
MANUFACTURERS ASSOCIATION



# I-900

## WELCOME TO OUR NEW CUSTOMERS!

Thank you for your purchase of an Ashland scraper and the confidence you have placed in us to handle your earthmoving projects. Years of research, testing and successful application have been spent to ensure quality and maximum performance for our customers. Please read and understand this manual before attempting to attach or operate this scraper. This manual should always remain with the machine. Be sure and fill out and send in the owners registration form at the beginning of this manual, or you may fill out the form on-line by going to [ashlandind.com](http://ashlandind.com) and click on "Register your Machine" at the bottom of the page.



## SCRAPER ID NUMBER

The serial number plate for the scraper is located on the right rear area of the scraper underneath the dirt shield. The letter and numbers stamped identify the serial number, model number and capacity of the scraper. Please record this serial number for use in ordering parts, warranty issues and to trace your equipment if it is ever stolen.

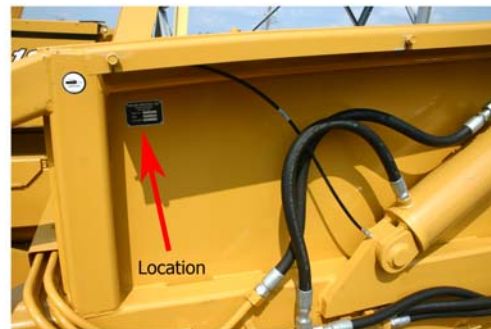

Located on the top left side under dirt shield





## **HOW TO ORDER PARTS:**

### **IMPORTANT**

Parts must be ordered through your local authorized ASHLAND dealer.

Be sure to state MODEL and SERIAL NUMBER of your machine, PART NUMBER, DESCRIPTION and QUANTITY needed.



Unless this is done, we cannot provide prompt service or assure shipment of the correct parts.

Ashland Industries weldable replacement parts are available to rebuild, modify or update your scraper to current factory specifications.

## **INDEX**

Page 3.	Safety Guidelines
Page 4-5.	Operators and Maintenance Instructions
Page 6.	Illustration Assembly
Page 7.	Gooseneck Frame Assembly – Illustration and Parts
Page 8.	Apron Assembly – Illustration and Parts
Page 9.	Bowl & Frame Assembly – Illustration and Parts
Page 10.	Push Off Gate Assembly – Illustration and Parts
Page 11.	Pole and Axle Assembly – Illustration and Parts
Page 12.	Wheel, Hub and Spindle – Illustration and Parts
Page 13.	Hydraulic Cylinder (Dig & Lift) 4" X 16"
Page 14.	Hydraulic Cylinder (Apron –right & left) 3 ½" X 10"
Page 15.	Hydraulic Cylinder – (Pushgate) 4" X 50"
Page 16-19.	Hydraulic Plumbing
Page 20-22.	Hydraulic Manifold
Page 23.	Warranty Statement



## SAFETY SIGNAL WORDS

Note the use of the signal words DANGER, WARNING and CAUTION with the safety messages. The appropriate signal word for each has been selected using the following guidelines:



**DANGER:** Indicates an imminently hazardous situation that, if not avoided, will result in death or serious injury. This signal word is to be limited to the most extreme situations typically for machine components which, for functional purposes, cannot be guarded.



**WARNING:** Indicates a potentially hazardous situation that, if not avoided, could result in death or serious injury, and includes hazards that are exposed when guards are removed. It may also be used to alert against unsafe practices.



**CAUTION:** Indicates a potentially hazardous situation that, if not avoided, may result in minor or moderate injury. It may also be used to alert against unsafe practices.



## GENERAL SAFETY GUIDELINES

Safety of the operator is one of the main concerns in designing and developing a new piece of equipment. Designers and manufacturers build in as many safety features as possible. However, every year many accidents occur which could have been avoided by a few seconds of thought and a more careful approach to handling equipment. You, the operator, can avoid many accidents by observing the following precautions in this section. To avoid personal injury, study the following precautions and insist those working with you, or for you, follow them.

Replace any CAUTION, WARNING, DANGER or instruction safety decal that is not readable or is missing. Location of such decals is indicated in this booklet.

Do not attempt to operate this equipment under the influence of drugs or alcohol.

Review the safety instructions with all users annually.

This equipment is dangerous to children and persons unfamiliar with its operation. The operator should be a responsible adult familiar with farm machinery and trained in this equipment's operations. **Do not allow persons to operate or assemble this unit until they have read this manual and have developed a thorough understanding of the safety precautions and of how it works.**

To prevent injury or death, use a tractor equipped with a Roll Over Protective System (ROPS). Do not paint over, remove or deface any safety signs or warning decals on your equipment. Observe all safety signs and practice the instructions on them.

Never exceed the limits of a piece of machinery. If its ability to do a job, or to do so safely, is in question - **DON'T TRY IT.**

## OPERATORS AND MAINTENANCE INSTRUCTIONS

This scraper is a durable piece of equipment and with proper care will yield many years of trouble free operation. The scraper requires a power source with TWO 4 way (double acting) hydraulic control valves.

The scraper should be greased at all points where grease fittings are provided. Connect hydraulic hoses to the tractor and retract lift cylinders to **REMOVE TRANSPORT LOCK PINS**, then extend and retract all cylinders several times to force out any air from the hydraulic cylinders and lines. Check the oil levels in the tractor hydraulic system and add to maintain the proper level. Care should be used when adding oil or when disconnecting any oil line to keep all dirt out of the oil as dirt is a major factor in the failure of hydraulic components.

When the scraper is placed into operation, the operator will have to “feel out” the amount of depth of cut to obtain maximum loading efficiency. This is usually accomplished by taking a lesser and more uniform cut; however, some soil conditions such as loose sand may require a “pumping action” obtained by taking successive deep cuts and lifting out of cut as the tractor begins to lose power or traction.

1. After 10 hours work, all bolts should be checked and tightened if necessary.
2. Every 10 hours all grease fittings should be lubricated.
3. After 50 hours work, all bolts should be rechecked and tightened if necessary. Check wheel bearings and adjust if necessary.
4. After 300 hours work, clean and repack wheel bearings and replace, if necessary, cutting edges, worn pins, etc.

## WARNING



### **Check Tires and Wheels**

**The task of servicing tires and wheels can be extremely dangerous and should be performed by trained personnel only, using the correct tools and following specific procedures. Do not attempt to mount, demount or inflate a tire if you do not have the proper equipment and experience to perform the job. Call a qualified repair service to inspect the assembly and make necessary repairs. Failure to heed warnings could lead to serious injury or death.**

Visually inspect tires and wheels daily. Carefully inspect any rim and tire assembly that has been run underinflated or flat before reinflating the tire to make sure there is no damage to either the rim or tire.

- ALWAYS wear personal protection equipment such as gloves, footwear, eye protection, hearing protection and head gear when servicing tire and wheel components.
- DO NOT operate with damaged rims, tire cuts or bubbles, missing lug bolts or nuts or damaged rims.
- ALWAYS maintain the correct tire pressure. NEVER exceed recommended tire inflation pressure.
- INSPECT any rim and tire assembly that has been run flat or severely underinflated before reinflating the tire. Damage to the rim and tire may have developed.
- NEVER inflate a tire that has lost air pressure or has been run flat without determining and correcting the problem.
- NEVER try to repair wheel, rim, or tire components parts. Parts that are cracked, worn, pitted with corrosion, or damaged must be discarded, and replaced with good parts.
- ALWAYS use approved tire and rim combinations for the model scraper that you have and verify that part numbers of components are correctly matched for the assembly.
- ALWAYS exhaust all air from the tire prior to demounting.
- ALWAYS place wheel and tire assemblies in restraining devices (safety cage) when inflating tires. Use a clip-on chuck and long extension hose to allow you to stand to the side of the tire and not in front of it.
- NEVER weld or cut on an inflated tire assembly. Welding heat can cause increased pressure which could result in tire explosion.
- ALWAYS use proper lifting techniques, and mechanized lifting aids to move heavy components and assemblies.
- NEVER leave a tire, wheel, or assembly unsecured in a vertical position.
- ALWAYS take care when moving tires and wheels that other people in the area are not endangered.

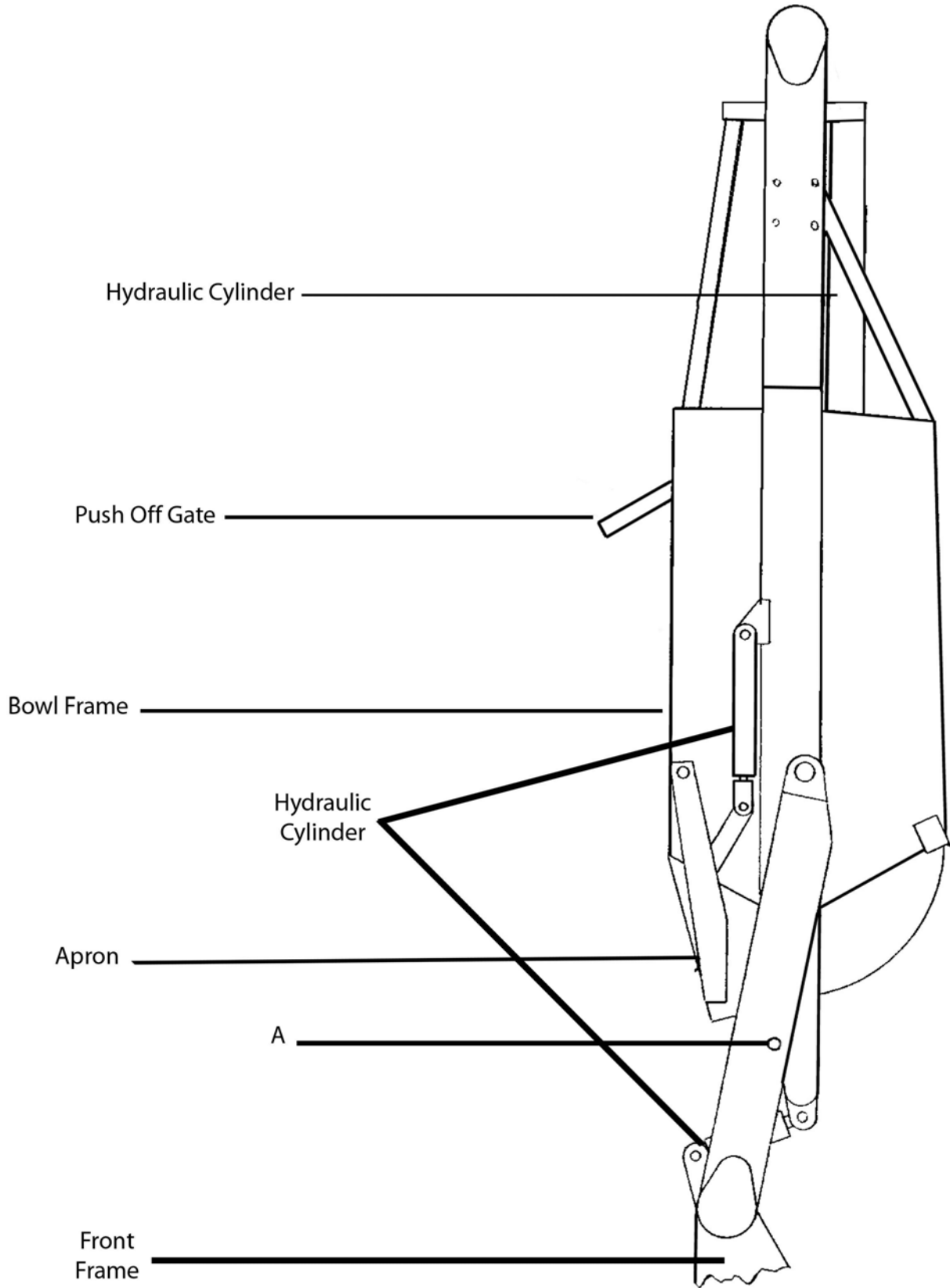

I-Series Assembly-ILL

GOOSENECK FRAME ASSEMBLY

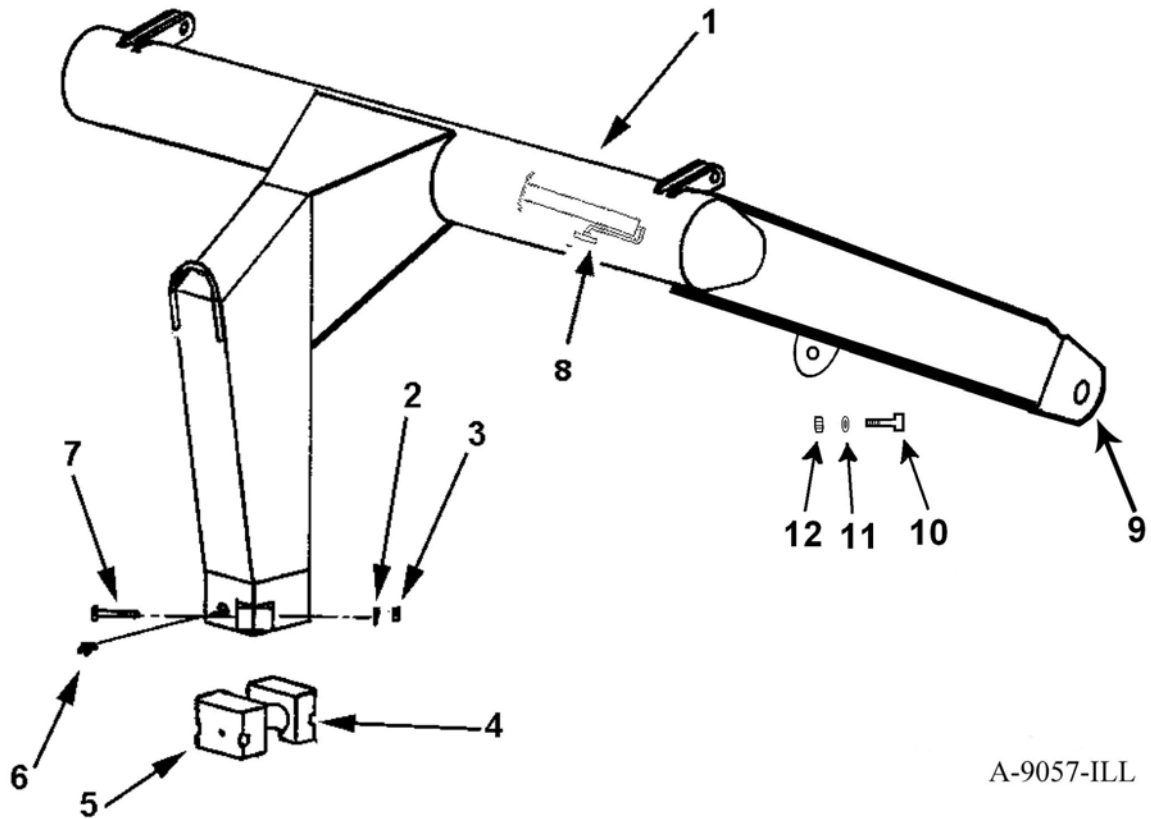

A-9057-ILL

Key Number	Part Number	Description
1	A9057	Gooseneck Frame
2	8110	Lock washer 5/8"
3	7536	Nut, 5/8" NF
4	A90004	Cast Socket half, rear
5	A90005	Cast Socket half, front with zerk hole
6	A2206	Grease Zerk, Long Shank
7	AFB-00043	Bolt, 5/8" x 4 1/2" NF
8	OPT-00001	Hitch Jack
9	AHF-00028	Grease Fitting 90° 1/8 NPT
10	AFB-00018	Bolt: 1"NC X 3" Gr 8
11	AFW-00001	Washer 1" Flat
12	AFN-00012	Nut: 1" NC Gr 8



## APRON ASSEMBLY

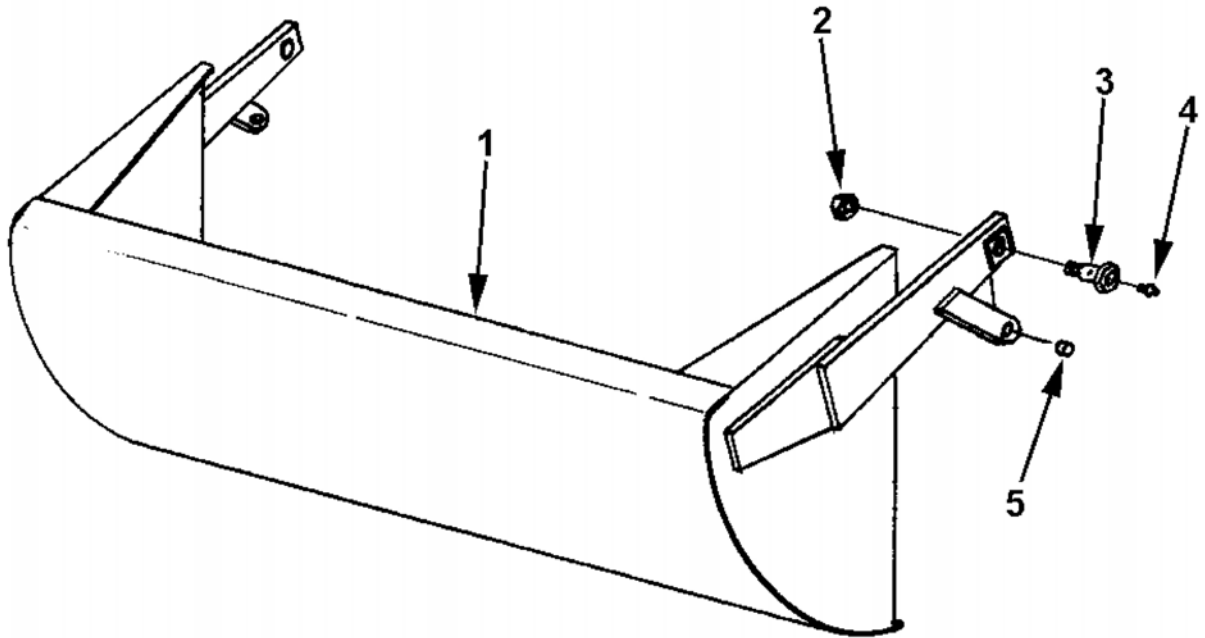

A-8060-III

Key Number	Part Number	Description
1	A8060	Apron
2	AFN-00009	Self Locking Nut, 1-1/4"
3	A6010	Shoulder pin, 1-5/8" - 1-1/4" with zerk in head
4	14505	Grease Fitting
5	A10155	Bushing, 1" ID x 1-1/2" OD x 1-1/8" Long Steel

**BOWL AND FRAME ASSEMBLY**

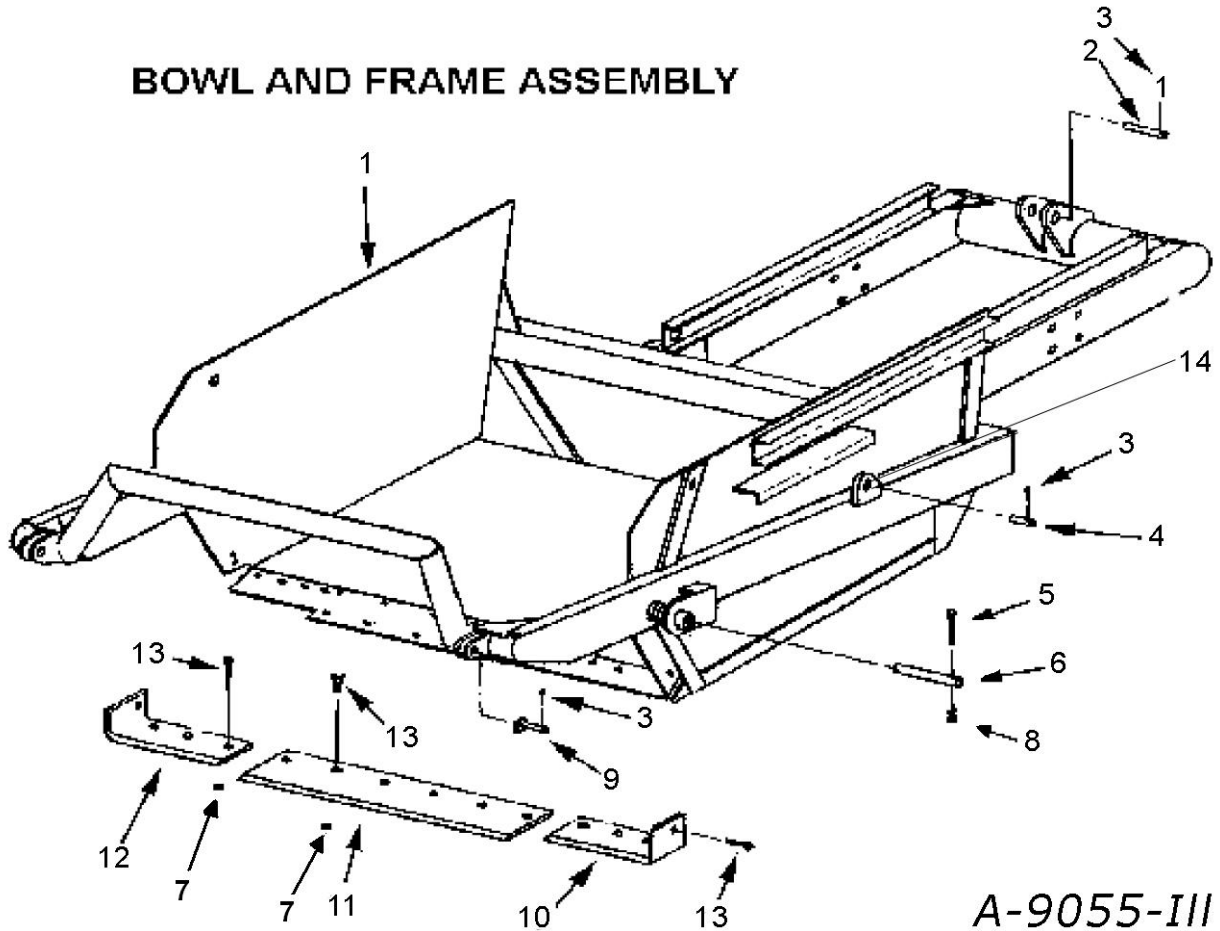

A-9055-III

**Blade Bolts Required:**

		<u>Qty</u>
A8030	PB8P-NC-063-0200	(6)
A8029A	PB8P-NC-063-0200	(4)
A8031A	PB8P-NC-063-0200	(4)

Key Number	Part Number	Description
1	A9055	Bowl and Frame
2	A8062	Pin, 1-1/4" x 7"
3	AFP-00002	Cotter Pin, 3/16" x 1-3/4"
4	A1217	Pin, 1" x 3-1/2"
5	AFB-00054	Bolt, 1/2" NC x 3-1/2"
6	A8056	Pin, 1-3/4" x 7-3/4"
7	7530	Nut: 5/8" NC
8	AFN-00011	Nut, 1/2" NC
9	A10168	Pin, 1-1/8" x 4-1/4"
10	A8031A	Left Cutting Edge
11	A8030	Center Cutting Edge
12	A8029A	Right Cutting Edge
13	PB8P-NC-063-0200	Plow Bolt, 5/8" x 2"
14	14505	Grease Fitting, 1/8 UPT

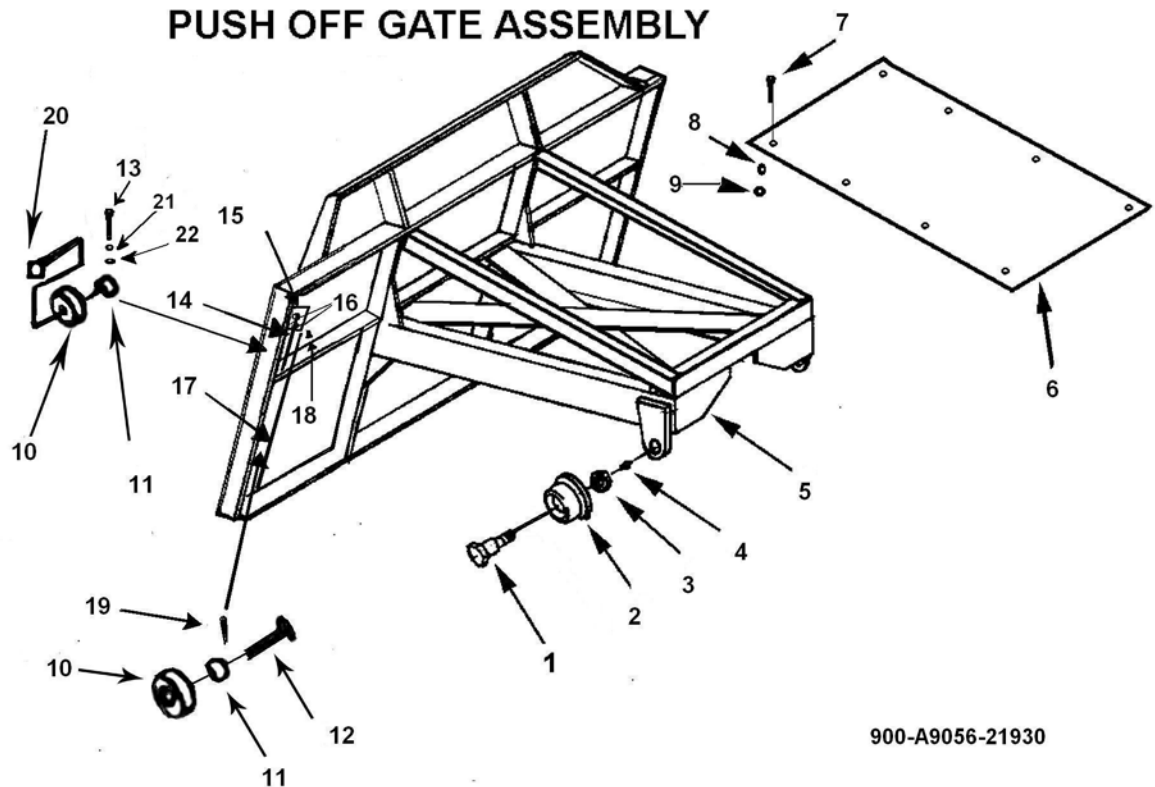

900-A9056-21930

Key Number	Part Number	Description
1	A10008	Shoulder Pin, 1 5/8" to 1 1/4" with zerker in threaded end
2	A123306	Roller, gate rear with flange type
3	AFN-00024	Jam Nut, 1 1/4" NF
4	14505	Grease Fitting, 1/8" NPT straight
5	A9056	Push Off Gate
6	A9058	Dirt Shield
7	AFB-00015	Bolt, 1/2" NC X 1 1/2"
8	8100	Lockwasher, 1/2"
9	AFN-00011	Nut, 1/2" NC
10	A10164	Roller: 41/4 OD x 1 3/4 ID
11	A10163	Bushing: 1 3/4" OD X 1 1/4" ID
12	A6007A	Pin: 1 1/4" X 4 1/8" Lg.
13	7036	Bolt: 1/2 NC X 2 Gr 8
14	A125020	32" Greaseline
15	A123323-40	Double Hole Tab
16	A125026	Bulkhead Nut
17	A125021	54" Greaseline
18	A125019	Grease Fitting 1/4 - 28: 54 L
19	AFP-00001	Cotter Pin: 1/4 X 3 Lg.
20	A123288	Pin: 1 1/4 X 3 1/4 Tab Head
21	8100	1/2" Lockwasher
22	7500	Nut: 1/2 NC

# I-900

## Pole & Axle Assembly

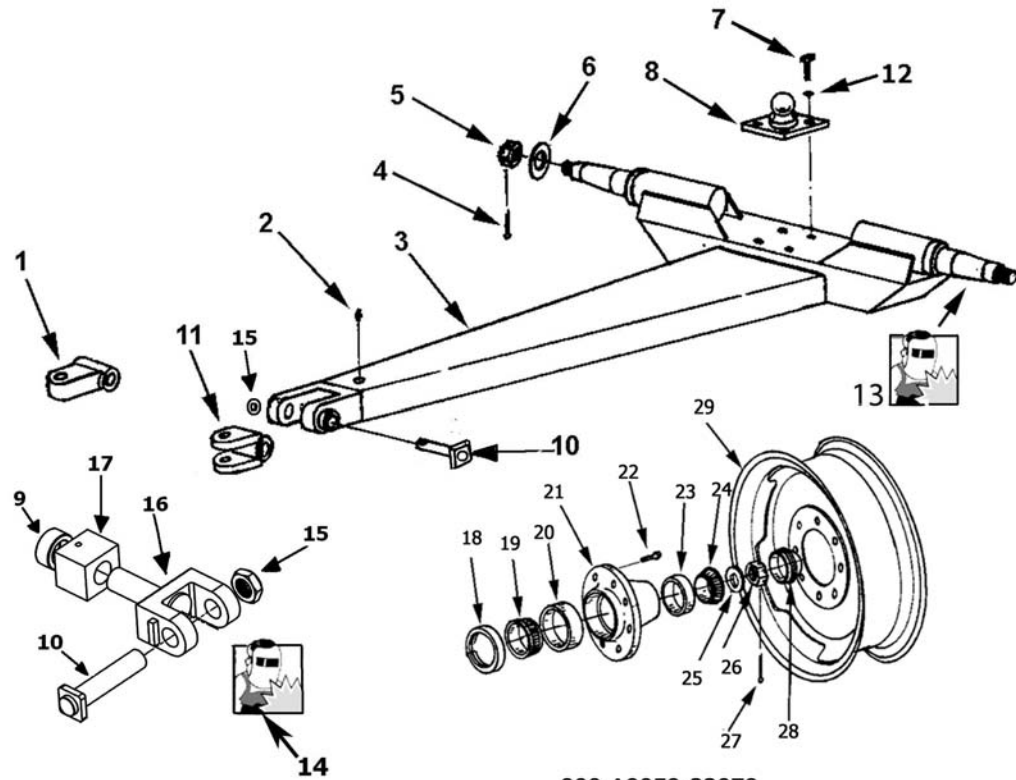

900-A9059-22079

Key Number	Part Number	Description
1	A10033A	Single Lip Hitch
2	14505	Grease Fitting, 1/8 NPT
3	A9059	Pole
4	AFP-00002	Cotter Pin, 3/16" X 1 3/4"
5	AFN-00010	Nut, castellated, 1 1/4" NF
6	A8027	Washer, special, 1 1/4" flat
7	AFB-00005	Bolt, 3/4" NC X 2 1/2" L
8	A40006	Ball Swivel
9	A030568-01	Hitch Collar
10	600053	Pin, Swivel Hitch
11	A10033	Double Lip Clevis Hitch
12	AFW-00002	Lockwasher, 3/4"
13	A9062	Weld, Spindle Blank
14	A031076W	Yoke Hitch Rebuild Kit (Containing items: 9,10,15,16,17)
15	500433	Nut: Jam
16	A030168-3A	Swivel Yoke Assembly
17	A030568-1	Swivel Block
18	A8020	Grease Seal (CR 35062)
19	A9061	Bearing Cone, inner
20	A8022	Bearing Cup, inner
21	A8023	Hub
22	A4519	Wheel Bolt, 9/16" NF
23	A8024	Bearing Cup, outer
24	A8025	Bearing Cone, outer
25	A8027	Spindle washer, special
26	AFN-00005	Spindle Nut
27	AFP-00002	Cotter Pin, 3/16" X 1 3/4"
28	A8026	Hub Cap
29	A6022A	Wheel, 16.1 X 11" DC

# I-900

## Rear Wheel & Hub Assembly

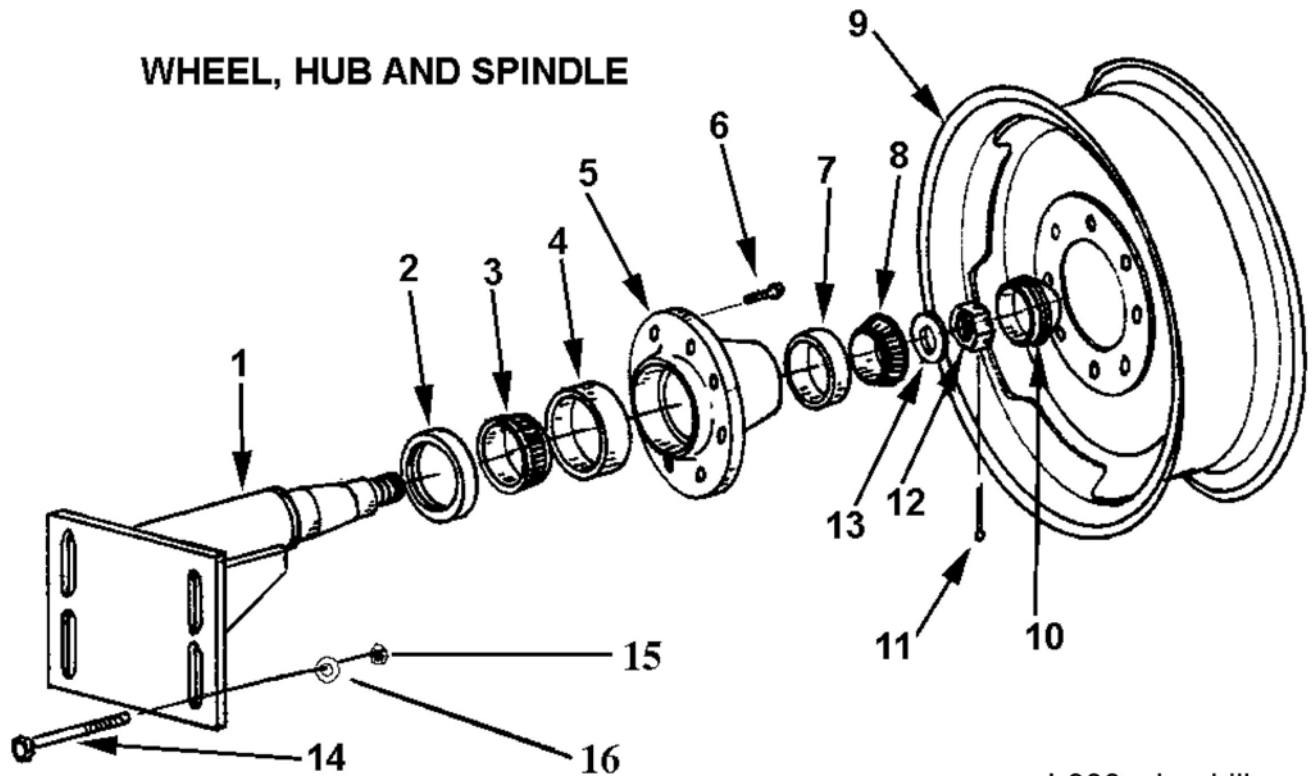

Key Number	Part Number	Description
1	A9060	Spindle, Rear with flange base plate
2	A8020	Grease Seal (CR 35062)
3	A9061	Bearing Cone, inner
4	A8022	Bearing Cup, inner
5	A8023	Hub
6	A4519	Wheel Bolt, 9/16" NF
7	A8024	Bearing Cup, outer
8	A8025	Bearing Cone, outer
9	A6023	Rear Wheel 24" x 15"
10	A8026	Hub Cap
11	AFP-00002	Cotter Pin, 3/16" x 1-3/4"
12	AFN-00005	Spindle Nut
13	A8027	Spindle washer, special
14	AFP-00001	Bolt, 1" NC x 6-1/2" long
15	AFN-00012	Nut, 1" NC
16	AFW-00001	Flat Washer, 1"

## HYDRAULIC CYLINDER DIG AND LIFT CIRCUIT

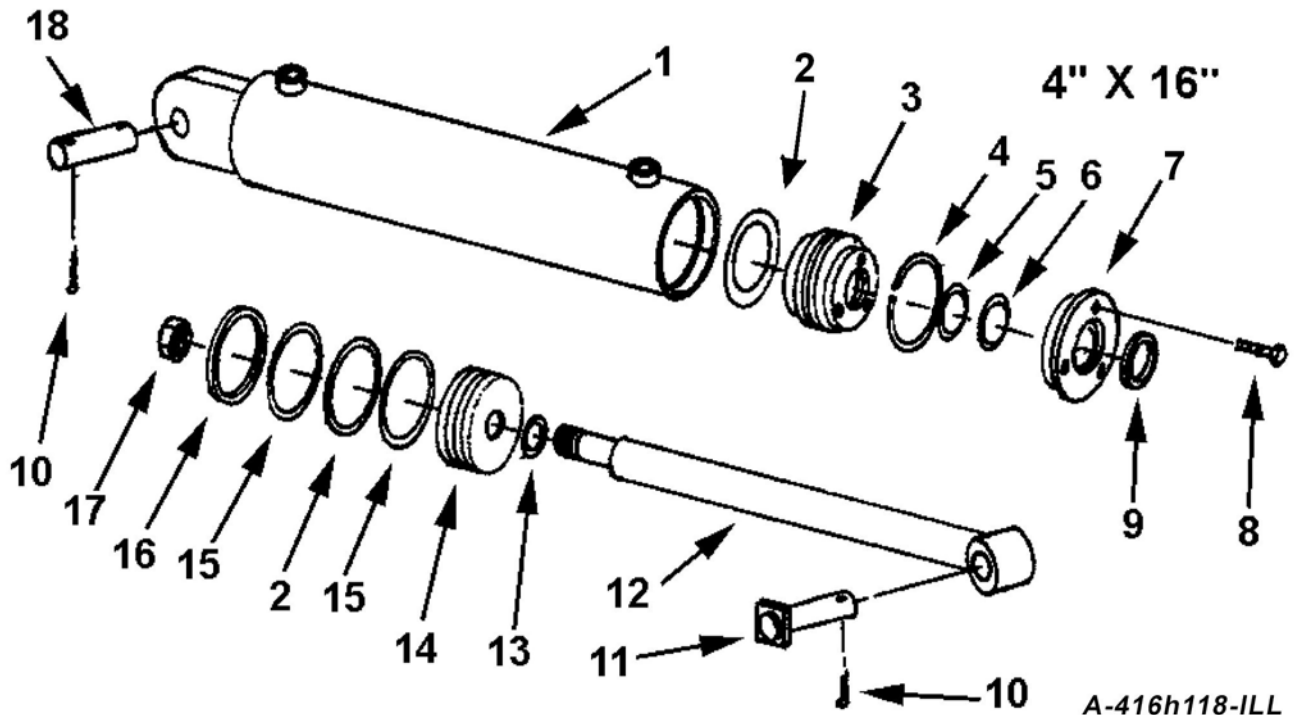

Key Number	Part Number	Description
1	A45H04	Barrel Assembly
2	A300H06	O-ring, 4" OD x 3/16"
3	A300H11	Head Gland
4	A300H12	Retainer Ring
5	A22H15	O-ringm 1-1/2" ID x 1/8"
6	A22H15A	Backup Washer
7	A300H13	Head Cap
8	A22H18	Capscrew, 1/4" x 1"
9	A22H17	Wiper Seal, 1-1/2" diameter
10	AFP-00003	Cotter Pin, 3/16" x 1-1/2"
11	A10168	Pin, 1-1/8" x 4-1/4"
12	A45H03-118	Shaft, 1-1/2" diameter
13	A45H05	Piston Gasket 1" ID
14	A300H07	Piston, 4"
15	A300H05	Cast Iron ring, 4" OD
16	A300H04	Backup Washer, 4" OD
17	A300H03	Piston Nut
18	A45003	Pin, 1-1/8" x 3-1/4"
	A300H14B	Packaging Kit ,containing: 1-A300H04 1-A22H15 2-A300H05 1-A22H15A 2-A300H06 1-A22H17 1-A45H05

**HYDRAULIC CYLINDER**      **A3510H1**      **APRON CIRCUIT,**  
**3-1/2" X 10"**      **Right & Left Side**

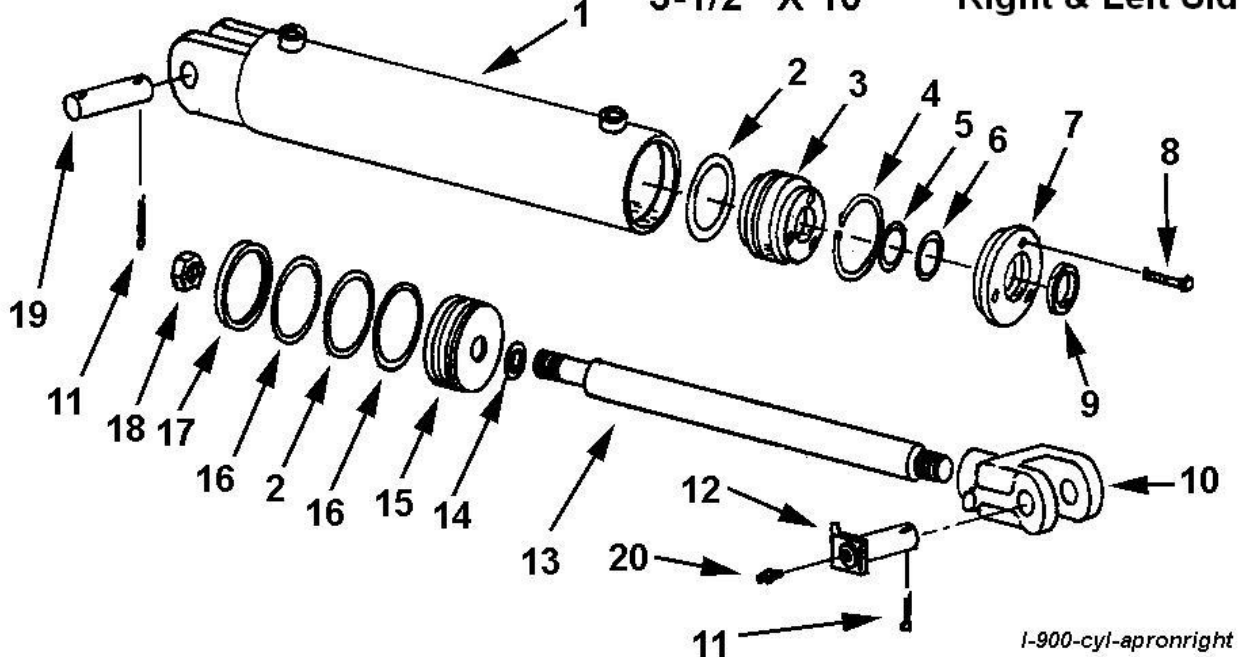

*I-900-cyl-apronright*

Key Number	Part Number	Description
1	A12H04	Barrel
2	A22H08	O-ring, 3-1/2" OD
3	A22H13	Head Gland
4	A22H14	Retainer Ring
5	A22H15	O-ring, 1-1/2" ID x 1/8" thickness
6	A22H15A	Backup Washer
7	A22H16	Head Cap
8	A22H18	Socket head capscrew, 1/4 x 1"
9	A22H17	Wiper Seal, 1-1/2" ID
10	A12H03	Clevis end
11	AFP-00003	Cotter Pin, 3/16" x 1-1/2"
12	A10167	Pin, 1" x 3-9/16"
13	A12H02	Shaft, 1-1/2" diameter
14	A22H10	Piston Gasket, 3/4" ID
15	A22H09	Piston
16	A22H07	Backup Washer, 3-1/2" x OD
17	A22H06	Piston Ring, 3-1/2" x 3/16"
18	A22H05	Piston Nut, 3/4" NF
19	A1217	Pin, 1" x 3-1/2"
20	14505	Grease Fitting
	A22H19B	Packaging Kit ,containing: 1-A22H06 2-A22H07 2-A22H08 1-A22H10 1-A22H14 1-A22H15 1-A22H15A 1-A22H17 1-14505 1-A22H19B

# I-900

## Hydraulic Cylinder, Push Gate Circuit 4" x 50"

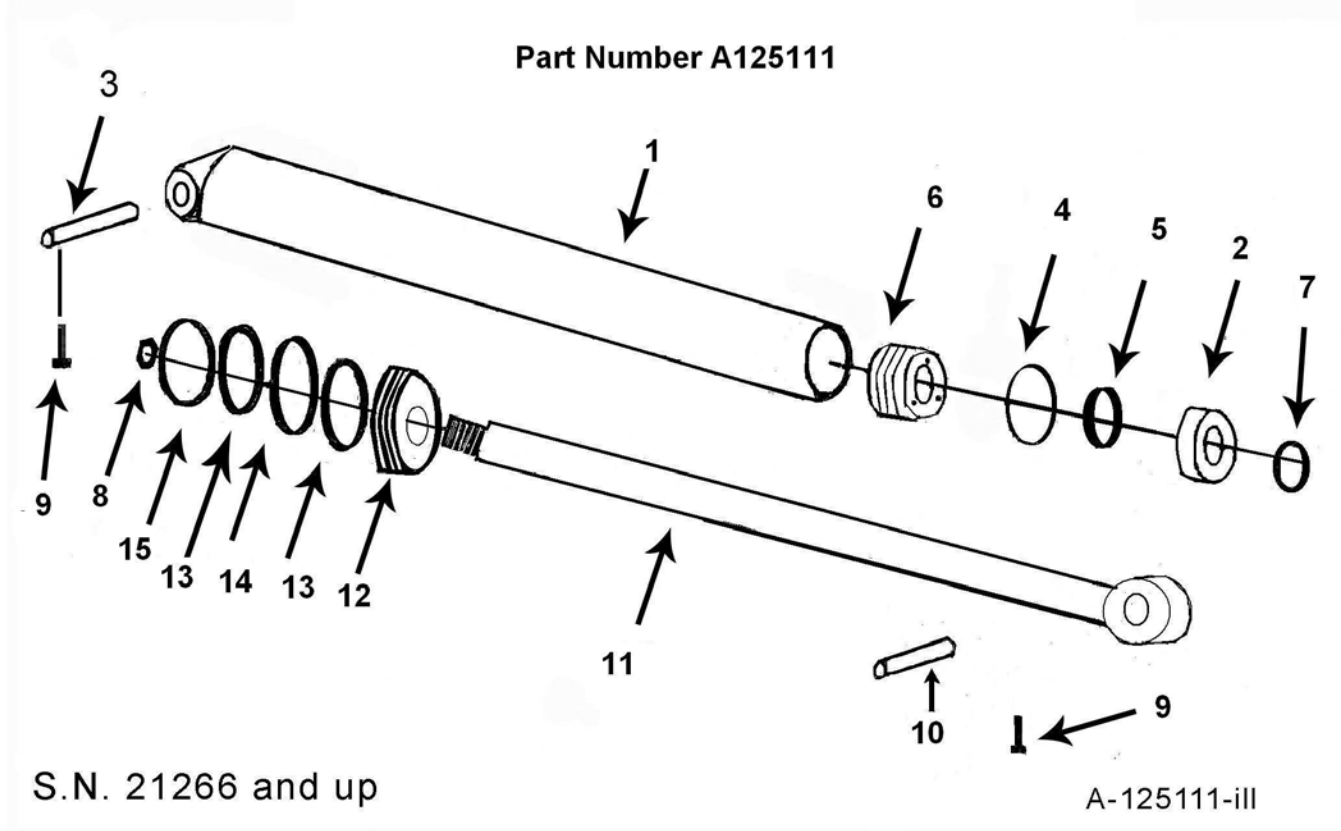

Key Number	Part Number	Description
1	A123424	Barrel Assembly
2	A123426	Collar
3	A8062	Pin, 1-1/4" x 7"
4	A80H24	O-ring, 4" OD x 1/8"
5	A400H12B	Seal: U-Cup
6	A123425	Head Gland
7	A80H06	Wiper Seal, 2" ID
8	A400H17	Piston Nut, 1-1/4" NF
9	8602	Cotter Pin, 1/4" x 2"
10	A8061	Pin, 1-1/4" x 4-3/4"
11	A90H26	Rod Assembly
12	A80H27	Piston
13	A300H05	Backup Washer, 4" OD
14	A300H06	O-ring, 4" OD x 3/16"
15	A300H04	Cast Iron Ring, 4" OD
	A80H30	Packaging Kit containing: 1- A80H24 2-A300H05 1-A400H12 1-A300H06 1-A400H12A 1-A300H04 1-A80H06



# I-900

## Hydraulic Plumbing-Front Section

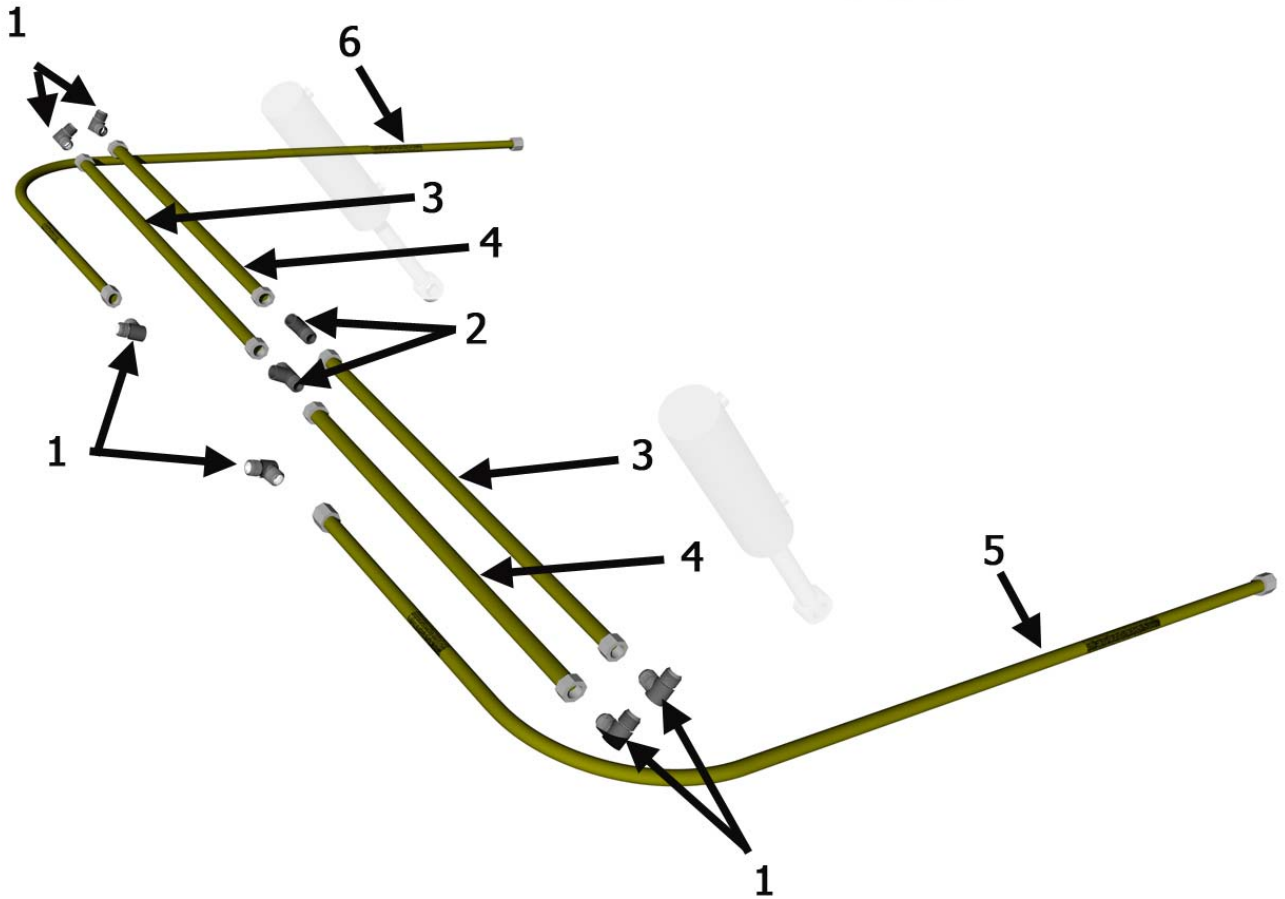

ILL-900-FS-PLMB-10-08

<u>ITEM</u>	<u>PART NO.</u>	<u>DESCRIPTION</u>
1	AHA-00019	Adapter: 90 Deg. $\frac{3}{4}$ MJ X $\frac{3}{4}$ MJ
2	AHA-00022	Adapter: T $\frac{3}{4}$ MJ X $\frac{3}{4}$ MJ X $\frac{3}{4}$ MJ
3	A125063	Tube Assembly: $\frac{3}{4}$ " X 32 $\frac{3}{4}$ "
4	A125064	Tube Assembly: $\frac{3}{4}$ " X 30 $\frac{1}{2}$ "
5	A125059-L	Tube Assembly: I-900 Left Front Arm
6	A125059-R	Tube Assembly: I-900 Right Front Arm

# I-900

## Hydraulic Plumbing-Rear Section

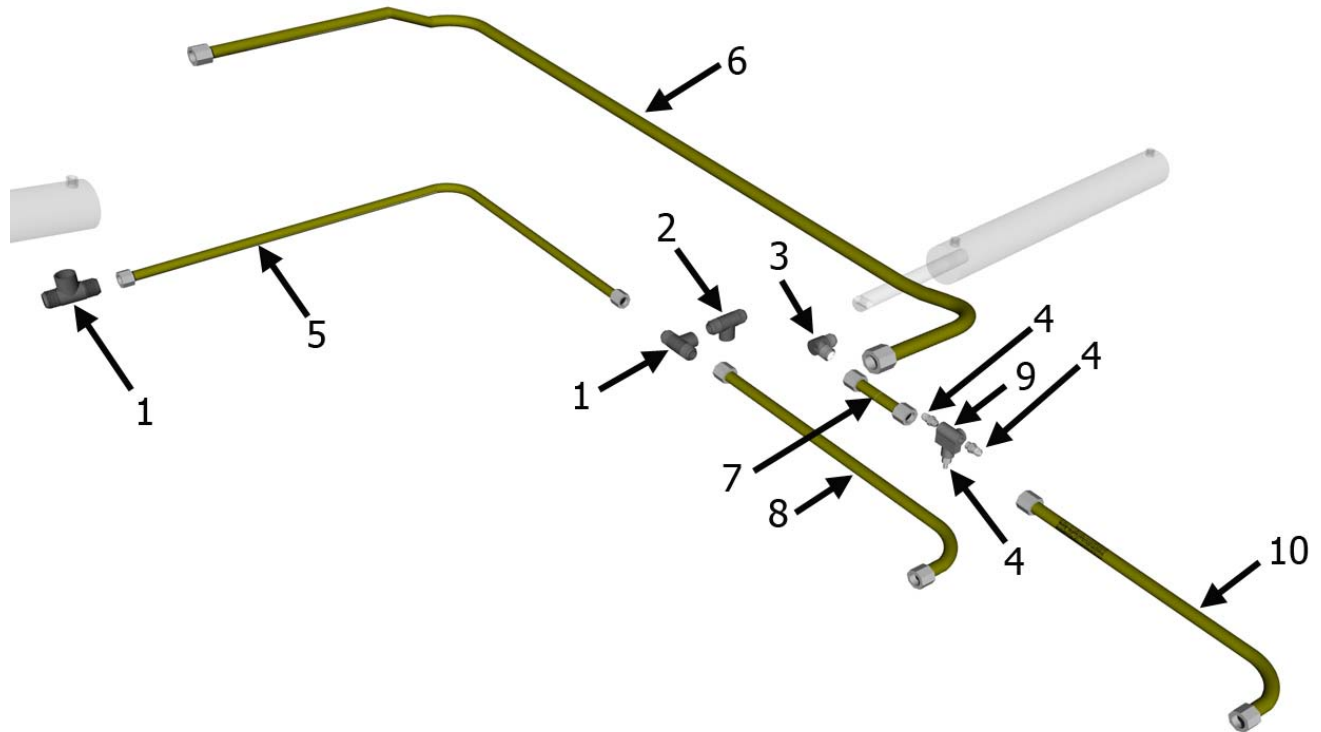

ILL-900-RS-PLMB-2-HL-1008

<u>ITEM</u>	<u>PART NO.</u>	<u>DESCRIPTION</u>
1	AHA-00022	Adapter: T $\frac{3}{4}$ MJ X $\frac{3}{4}$ MJ X $\frac{3}{4}$ MJ
2	AHA-00049	Adapter: T $\frac{3}{4}$ MJ X $\frac{3}{4}$ MJ X $\frac{3}{4}$ FJ Swiv.
3	AHA-00019	Adapter: 90 Deg. $\frac{3}{4}$ MJ X $\frac{3}{4}$ MJ
4	AHA-00006	Adapter: Str. $\frac{3}{4}$ MJ X $\frac{3}{4}$ MP
5	A125060	Tube Assy: $\frac{3}{4}$ " X 77 $\frac{3}{4}$ " w/-12 JIC Nuts & Sleeve
6	A125182	Tube Assy:
7	A155-H21	Tube Assy:
8	A125183	Tube Assy:
9	AHV-00001	Valve: Pressure Relief (in-line)
10	A125184	Tube Assy:

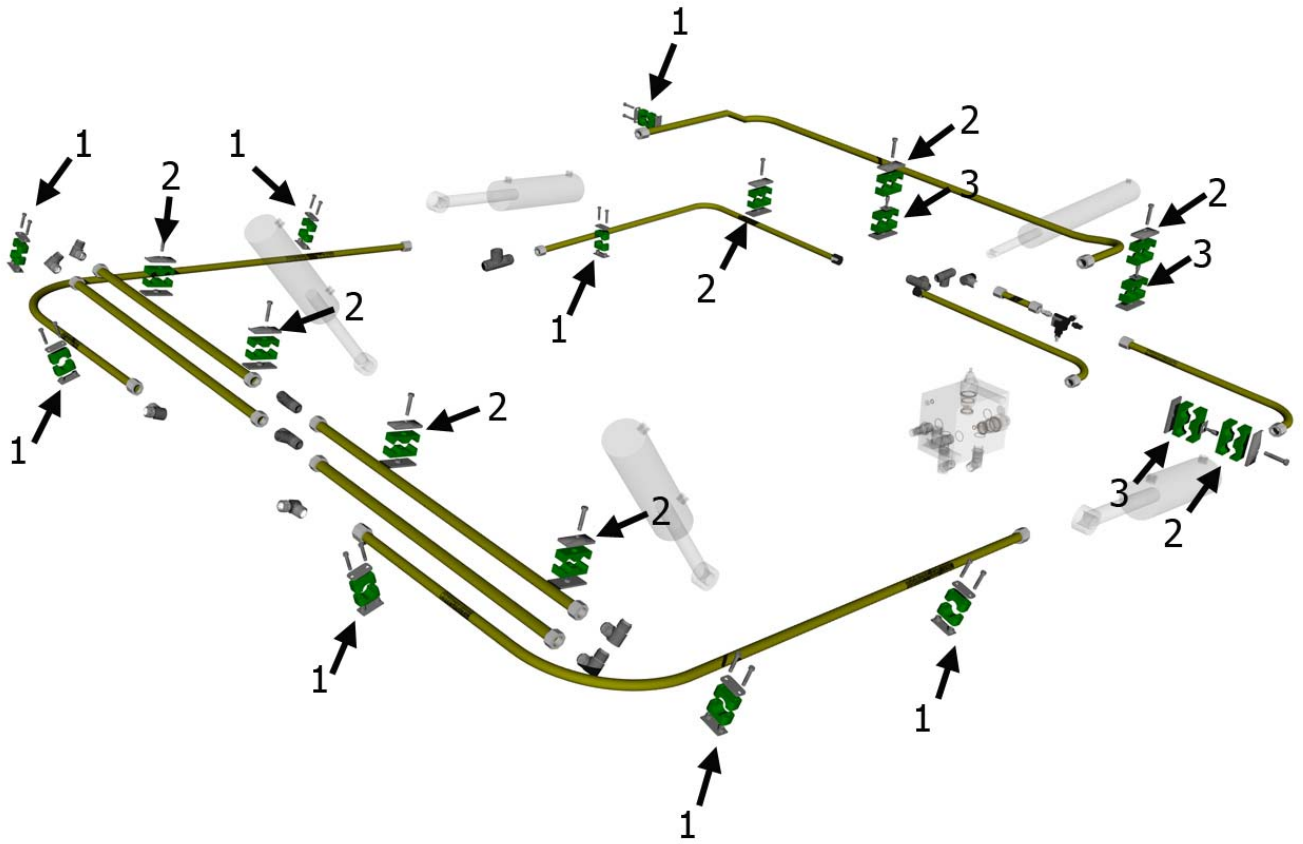

ILL-9-PMLB-2-CLMP-1008

<u>ITEM</u>	<u>PART NO.</u>	<u>DESCRIPTION</u>
1	AHL-00001	Clamp: Ass'y Hyd. Line – 1 Tube
2	AHL-00002	Clamp: Hyd. Line – 2 Tube Ass'y
3	AHL-00022	Clamp: Hyd. Line – 2 Tube Stack Ass'y

# I-900

## Hydraulic Hoses

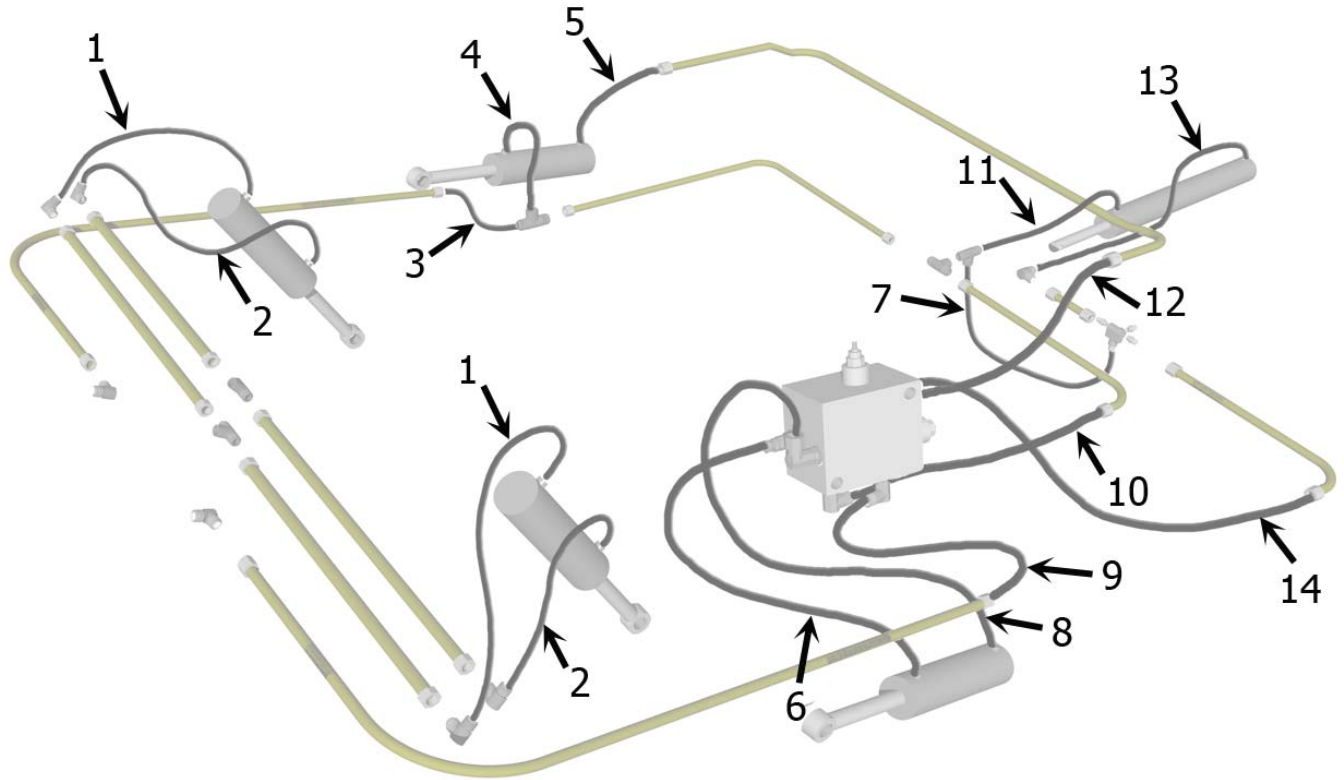

ILL-900-FSRS-2-SL-1008

<u>ITEM</u>	<u>ITEM NUMBER</u>	<u>DESCRIPTION</u>
1	A900-H12	Hose Assembly: ½ X 19 1/2" Lift Cyl. Top Tube
2	A900-H11	Hose Assembly: ½" X 25" Lift Cyl. Bottom Tube
3	A900-H10	Hose Assembly: ½" X 42" R. Tube – Front Arm
4	A900-H09	Hose Assembly: ½" X 25 ½" R. Apr. Cyl. Front Tube
5	A900-H08	Hose Assembly: ½" X 18" R. Apr. Cyl. Rear Tube
6	A900-H21	Hose Assembly: ½" X 23" L. Apr. Cyl. Rear Tube
7	A900-H05	Hose Assembly: ½" X 17" PRV-Tube @ Bowl Rear
8	A900-H20	Hose Assembly: ½" X 16" L. Apron Cyl. Top Tube
9	A900-H26	Hose Assembly: ½" X 48" To Valve Block
10	A900-H25	Hose Assembly: ½" X 20"
11	A900-H06	Hose Assembly: ½" X 25" Push-Off Cyl. Bottom Tube
12	A900-H22	Hose Assembly: ½" X 20"
13	A900-H24	Hose Assembly: ½" X 50" Push-Off Cyl.
14	A900-H23	Hose Assembly: ½" X 21"

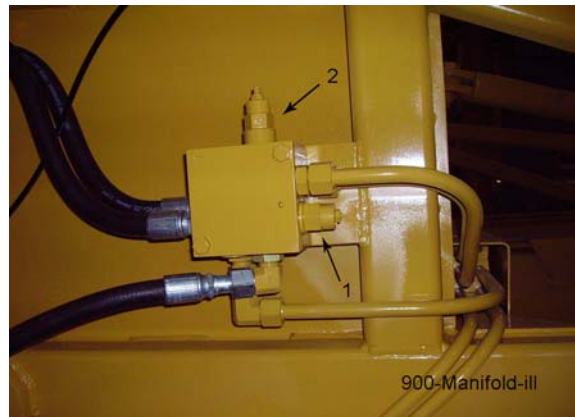

**IMPORTANT: This Hyd. Manifold was integrated into production April, 2006  
It replaces A125070 valve.**

**For older machines see master parts book on [Ashlandind.com](http://Ashlandind.com).**

**HYDRAULIC MANIFOLD ASSEMBLY  
A125174  
SETTING THE APRON AND PUSHOFF VALVE**

The manifold block containing the pushoff sequence valve cartridge and apron sequence valve cartridge is used to control two hydraulic circuits with one hydraulic remote. When the tractor hydraulic remote is activated, oil flows first to the apron cylinders until they are fully extended. Once the cylinders are fully extended, the apron circuit's hydraulic pressure begins to increase. Once the pressure threshold is surpassed (which is adjustable, see adjustment section), the sequence valve diverts the oil flow to the pushoff's hydraulic circuit. Once the push off is completely extended, the operator then reverses the tractor's hydraulic remote. The counterbalance valve will hold the apron open until the push off is fully retracted. The Apron sequence valve then opens and allows the apron to close.

**Setting the valves:**

**STEP 1 PUSHOFF SEQUENCE VALVE**

Loosen the lock nut (9/16") on the sequence valve cartridge. Turn the setscrew (4mm) clockwise until the front apron rises before the push-off begins to advance. (Earthmover should be empty) Turn the adjustment screw an additional 1/4 turn clockwise and tighten jam nut.

**STEP 2 COUNTER BALANCE VALVE**

Loosen the lock nut (9/16") on the counterbalance valve cartridge. Turn the setscrew (4mm) counter-clockwise until the apron holds in a raised position while rear gate is being retracted. Turn adjustment screw an additional 1/4 turn, tighten jam nut. **DO NOT** tighten adjusting screw more than necessary.

Key Number	Part Number	Description
1	A125162-01	Counterbalance Cartridge
2	A125162-02	Sequence Cartridge

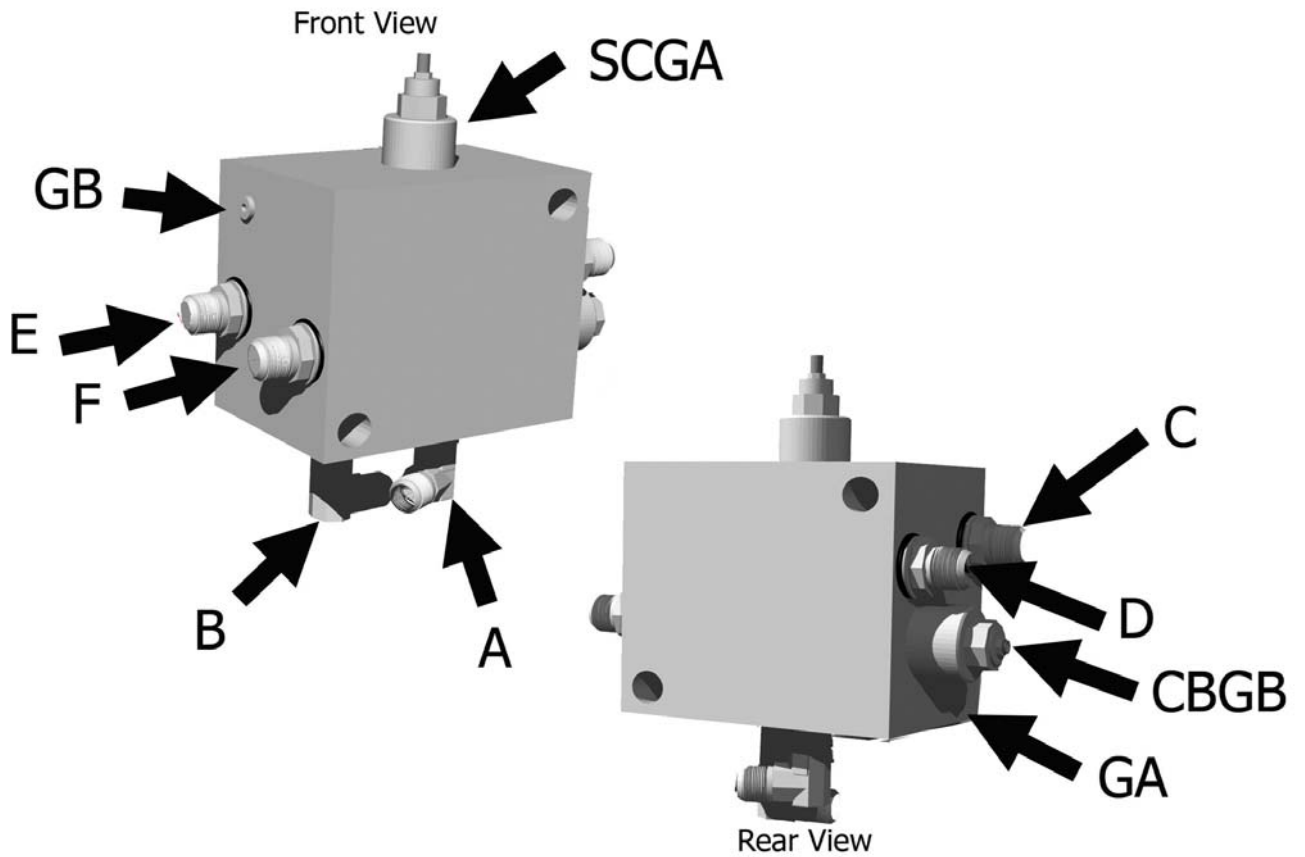

The lettering for the port locations are stamped on the block

A125174 Port Locations.ILL

Key Number	Description
A	Supply Line
B	Pushoff Cyl. (Rod End)-Apron Cyl, Right side (Rod End) -Supply Line
C	Pushoff Cylinder, (Base End)
D	Apron Cylinder, Right side (Base End)
E	Apron cylinder, Left side (Rod End)
F	Apron Cylinder, Left side, (Base End)
CBGB	Counterbalance Valve, adjustable
SCGA	Sequence Valve, adjustable
GA	Pressure test port
GB	Pressure test port

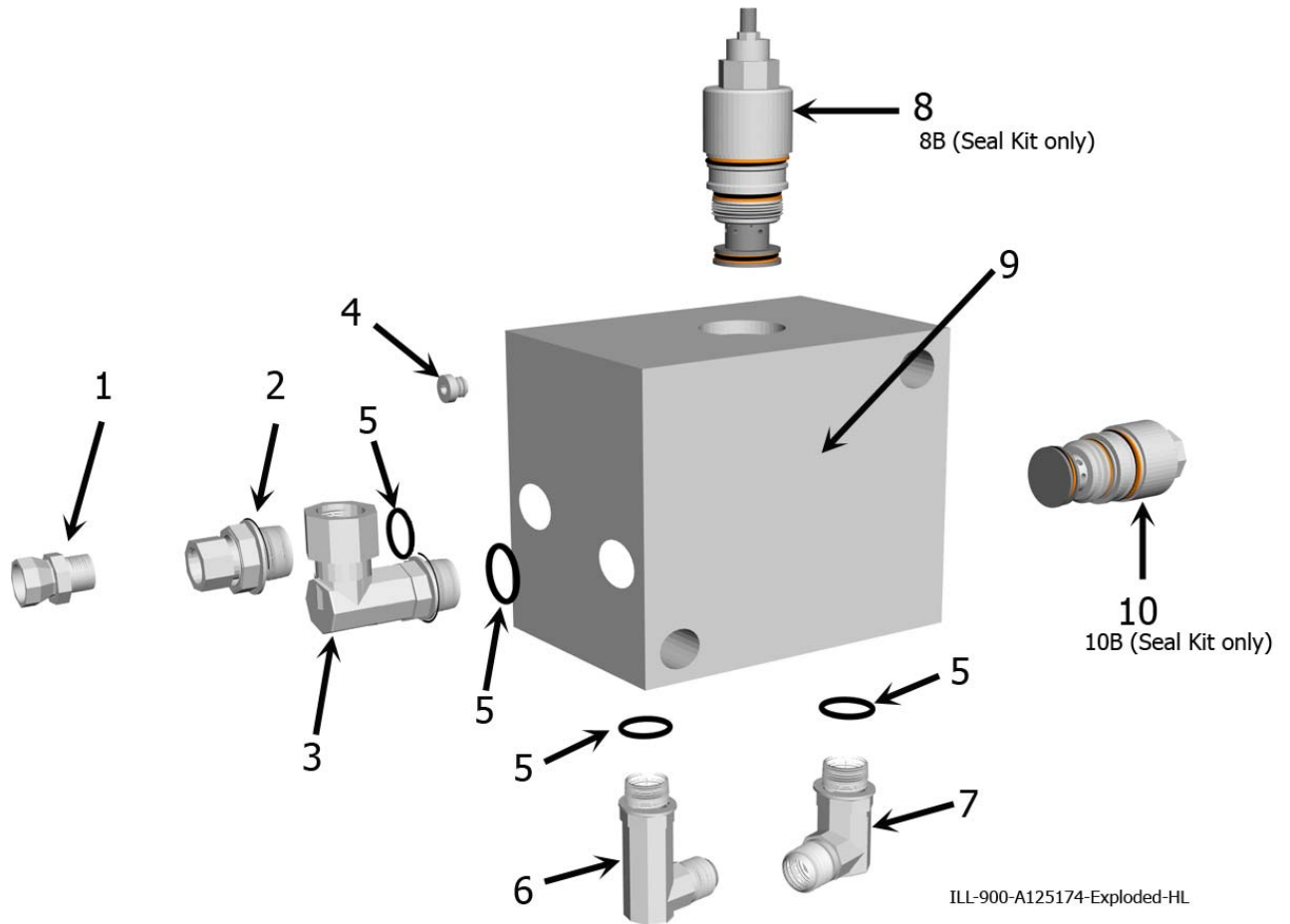

<b>ITEM</b>	<b>PART NO.</b>	<b>DESCRIPTION</b>
1	AHA-00076	Adapter: Str. Swiv 1/2 MP X 1/2 FP. 109 Rest
2	AHA-00043	Adapter: Str. Sw. 1 1/16 M ORB X 1/2 FP
3	AHA-00048	Adapter: 90 Deg. Swiv. 1 1/16 M ORB X 1/2 FP
4	AHA-00046	6 ORB Plug
5	AHS-00153	O-ring for 12 M ORB Fitting
6	AHA-00047	Adapter: 90 Deg. XL 3/4 MJ X 1 1/16 M ORB
7	AHA-00044	Adapter: 90 Deg. 3/4 MJ X 1 1/6 M ORB
8	A125162-02	Valve: Sequence Cartridge for Ver. III & IV
9	A125174	Valve: Manifold Block IV Body
10	A125162-01	Valve: Counterbalance Cartridge for Ver. III & IV

Seal Kits: A125162-01KIT Seal Kit for A125162-01 Valve Cartridge  
 A125162-02KIT Seal Kit for A125162-02 Valve Cartridge

## Limited Warranty Statement

Ashland Industries Inc. warrants each new product to be free from defects in material and workmanship. This warranty is applicable only for the normal service life expectancy of the product or components, not to exceed **six consecutive months** from the date of delivery of the new Ashland Industries product to the purchaser, or the date the product is first put into service via a rental agreement or other means, whichever occurs first.

The major components of swivel hitches used on Industrial series scrapers are warranted for three consecutive months from the date of delivery of the new Ashland Industries product to the purchaser, or the date the product is first put into service via a rental agreement or other means, whichever occurs first, except those components described below.

Genuine Ashland Industries Inc. replacement parts and components will be warranted for 30 days from date of purchase, or the remainder of the original equipment warranty period, whichever is longer.

Under no circumstances will it cover any merchandise or components thereof, which in the opinion of the company, has been subjected to misuse, unauthorized modification, alterations, an accident or if repairs have been made with parts other than those obtained through Ashland Industries Inc.

Ashland Industries Inc. in no way warrants tires since their respective manufacturer warrants these items separately. Please call Ashland Industries Inc. to receive phone numbers of tire suppliers.

Ashland Industries Inc. in no way warrants wearable items such as cutting edges, front dolly wheel balls, socket halves, rollers, bushings, yoke hitch pins, hitch bushings, etc.

Our obligation under this warranty shall be limited to repairing or replacing, free of charge to the original purchaser, any part that, in our judgment, shall show evidence of such defect, provided further that such part shall be returned within 30 days from the date of failure to Ashland Industries Inc. routed through the dealer and distributor from whom the purchase was made, transportation charges prepaid. Upon warranty approval proper credits will be reimbursed for transportation.

This warranty shall not be interpreted to render Ashland Industries Inc. liable for injury or damages of any kind or nature to person or property. This warranty does not extend to the loss revenue, extra labor cost associated with downtime, substitute machinery, rental or for any other reason.

Except as set forth above, Ashland Industries Inc. shall have no obligation or liability of any kind on account of any of its equipment and shall not be liable for special or consequential damages. Ashland Industries, Inc. makes no other warranty, expressed or implied, and, specifically, Ashland Industries Inc. disclaims any implied warrant or merchantability or fitness for a particular purpose. Some states or provinces do not permit limitations or exclusions of implied warranties or incidental or consequential damages, so the limitations or exclusion in this warranty may not apply.

This warranty is subject to any existing conditions of supply which may directly affect our ability to obtain materials or manufacture replacement parts.

Ashland Industries Inc. reserves the right to make improvements in design or changes in specifications at any time, without incurring any obligation to owners of units previously sold.

No one is authorized to alter, Modify or enlarge this warranty nor the exclusion, limitations and reservations.

Ashland Industries Inc.  
Warranty Department