

Ashland

EARTHMOVERS

I-180TS2

PARTS MANUAL

(BRAKE MODEL)

Ver 0809-22209



180-III

Ashland Industries Inc.
1115 Rail Drive
P.O. Box 717
Ashland, WI. 54806
877-634-4622 Toll Free - phone
715-682-4622 phone
715-682-9717 fax
www.ashlandind.com

MEMBER



CONSTRUCTION INDUSTRY
MANUFACTURERS ASSOCIATION



I-180TS2 BRAKE

WELCOME TO OUR NEW CUSTOMERS!

Thank you for your purchase of an Ashland scraper and the confidence you have placed in us to handle your earthmoving projects. Years of research, testing and successful application have been spent to ensure quality and maximum performance for our customers. Please read and understand this manual before attempting to attach or operate this scraper. This manual should always remain with the machine. Be sure and fill out and send in the owners registration form at the beginning of this manual, or you may fill out the form on-line by going to ashlandind.com and click on “Register your Machine” at the bottom of the page.

SCRAPER ID NUMBER

The serial number plate for the scraper is located on the right rear area of the scraper underneath the dirt shield. The letter and numbers stamped identify the serial number, model number and capacity of the scraper. Please record this serial number for use in ordering parts, warranty issues and to trace your equipment if it is ever stolen.

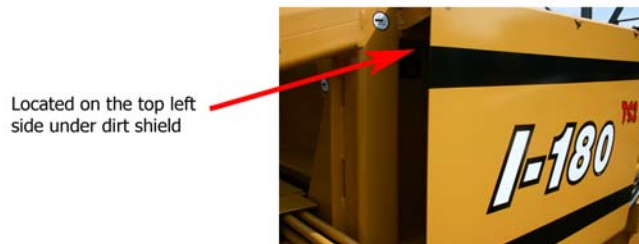
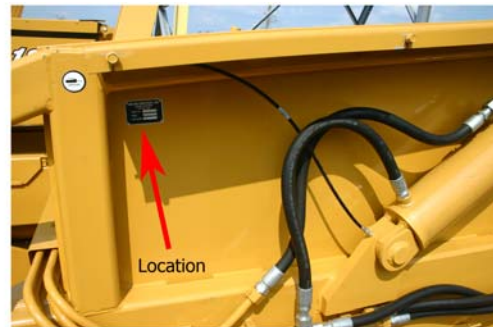

IMPORTANT

Please locate red Transport Links and remove prior to operation. Retract Lift Cylinder Circuit, Remove Safety Snap Pin, Remove link and replace into storage position as shown in figure 2. Do not use Transport Locks until scraper is completely empty of soil.

Reinstall Safety Snap Pins.

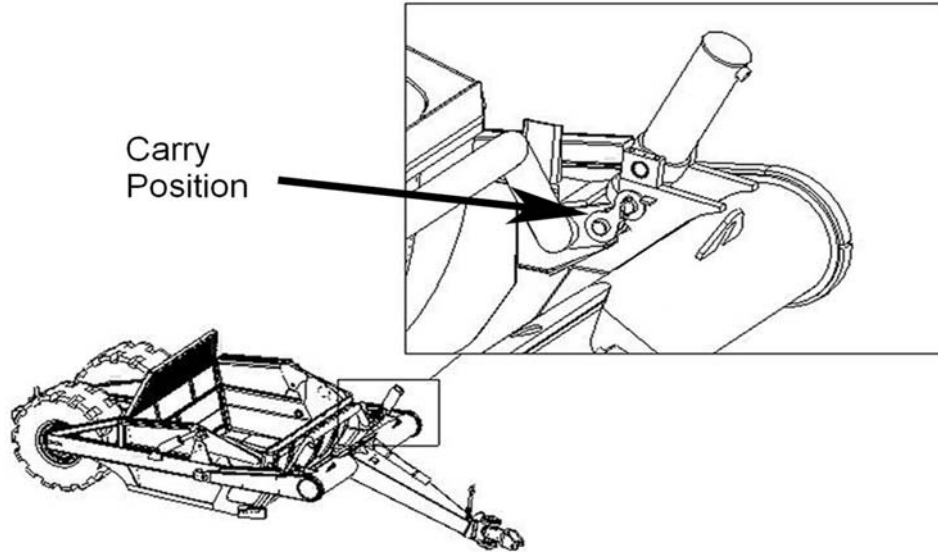

Storage Position

Figure 2

I-180TS2 BRAKE



HOW TO ORDER PARTS:

IMPORTANT

Parts must be ordered through your local authorized ASHLAND dealer.

Be sure to state MODEL and SERIAL NUMBER of your machine, PART NUMBER, DESCRIPTION and QUANTITY needed.



Unless this is done, we cannot provide prompt service or assure shipment of the correct parts.

Ashland Industries weldable replacement parts are available to rebuild, modify or update your scraper to current factory specifications.

Index

Page 4.	Operators and Maintenance Instructions
Page 5.	Safety Guidelines
Page 6.	Illustration – Assembly
Page 7.	Complete Yoke Type Hitch
Page 8.	Front Section Frame
Page 9.	Lift Cylinder 5 ½ X 20
Page 10.	Apron Assembly
Page 11.	Apron Cylinder
Page 12.-13.	Bowl and Frame Assembly
Page 14.-15.	Pushoff Gate Assembly
Page 16.	Push Off Cylinder
Page 17.	Wheel and Brake Assembly
Page 18.	Brake Replacement Directions
Page 19.-20	Hydraulic Valve-Identification, Illustration, Parts List and Adjustment
Page 21.	Hydraulic Schematic
Page 22.	Grease Locations
Page 23.-26.	Service Manual Appendiix
Page 27.	Warranty Statement

I-180TS2 BRAKE



HOW TO ORDER PARTS:

IMPORTANT

Parts must be ordered through your local authorized ASHLAND dealer.

Be sure to state MODEL and SERIAL NUMBER of your machine, PART NUMBER, DESCRIPTION and QUANTITY needed.



Unless this is done, we cannot provide prompt service or assure shipment of the correct parts.

Ashland Industries weldable replacement parts are available to rebuild, modify or update your scraper to current factory specifications.

Index

Page 4.	Operators and Maintenance Instructions
Page 5.	Safety Guidelines
Page 6.	Illustration – Assembly
Page 7.	Complete Yoke Type Hitch
Page 8.	Front Section Frame
Page 9.	Lift Cylinder 5 ½ X 20
Page 10.	Apron Assembly
Page 11.	Apron Cylinder
Page 12.-13.	Bowl and Frame Assembly
Page 14.-15.	Pushoff Gate Assembly
Page 16.	Push Off Cylinder
Page 17.	Wheel and Brake Assembly
Page 18.	Brake Replacement Directions
Page 19.-20	Hydraulic Valve-Identification, Illustration, Parts List and Adjustment
Page 21.	Hydraulic Schematic
Page 22.	Grease Locations
Page 23.-26.	Service Manual Appendiix
Page 27.	Warranty Statement

I-180TS2 BRAKE



SAFETY SIGNAL WORDS

Note the use of the signal words DANGER, WARNING and CAUTION with the safety messages. The appropriate signal word for each has been selected using the following guidelines:



DANGER: Indicates an imminently hazardous situation that, if not avoided, will result in death or serious injury. This signal word is to be limited to the most extreme situations typically for machine components which, for functional purposes, cannot be guarded.



WARNING: Indicates a potentially hazardous situation that, if not avoided, could result in death or serious injury, and includes hazards that are exposed when guards are removed. It may also be used to alert against unsafe practices.



CAUTION: Indicates a potentially hazardous situation that, if not avoided, may result in minor or moderate injury. It may also be used to alert against unsafe practices.



GENERAL SAFETY GUIDELINES

Safety of the operator is one of the main concerns in designing and developing a new piece of equipment. Designers and manufacturers build in as many safety features as possible. However, every year many accidents occur which could have been avoided by a few seconds of thought and a more careful approach to handling equipment. You, the operator, can avoid many accidents by observing the following precautions in this section. To avoid personal injury, study the following precautions and insist those working with you, or for you, follow them.

Replace any CAUTION, WARNING, DANGER or instruction safety decal that is not readable or is missing. Location of such decals is indicated in this booklet.

Do not attempt to operate this equipment under the influence of drugs or alcohol.

Review the safety instructions with all users annually.

This equipment is dangerous to children and persons unfamiliar with its operation. The operator should be a responsible adult familiar with farm machinery and trained in this equipment's operations. **Do not allow persons to operate or assemble this unit until they have read this manual and have developed a thorough understanding of the safety precautions and of how it works.**

To prevent injury or death, use a tractor equipped with a Roll Over Protective System (ROPS). Do not paint over, remove or deface any safety signs or warning decals on your equipment. Observe all safety signs and practice the instructions on them.

Never exceed the limits of a piece of machinery. If its ability to do a job, or to do so safely, is in question - **DON'T TRY IT.**

I-180TS2 BRAKE

Illustration Assembly

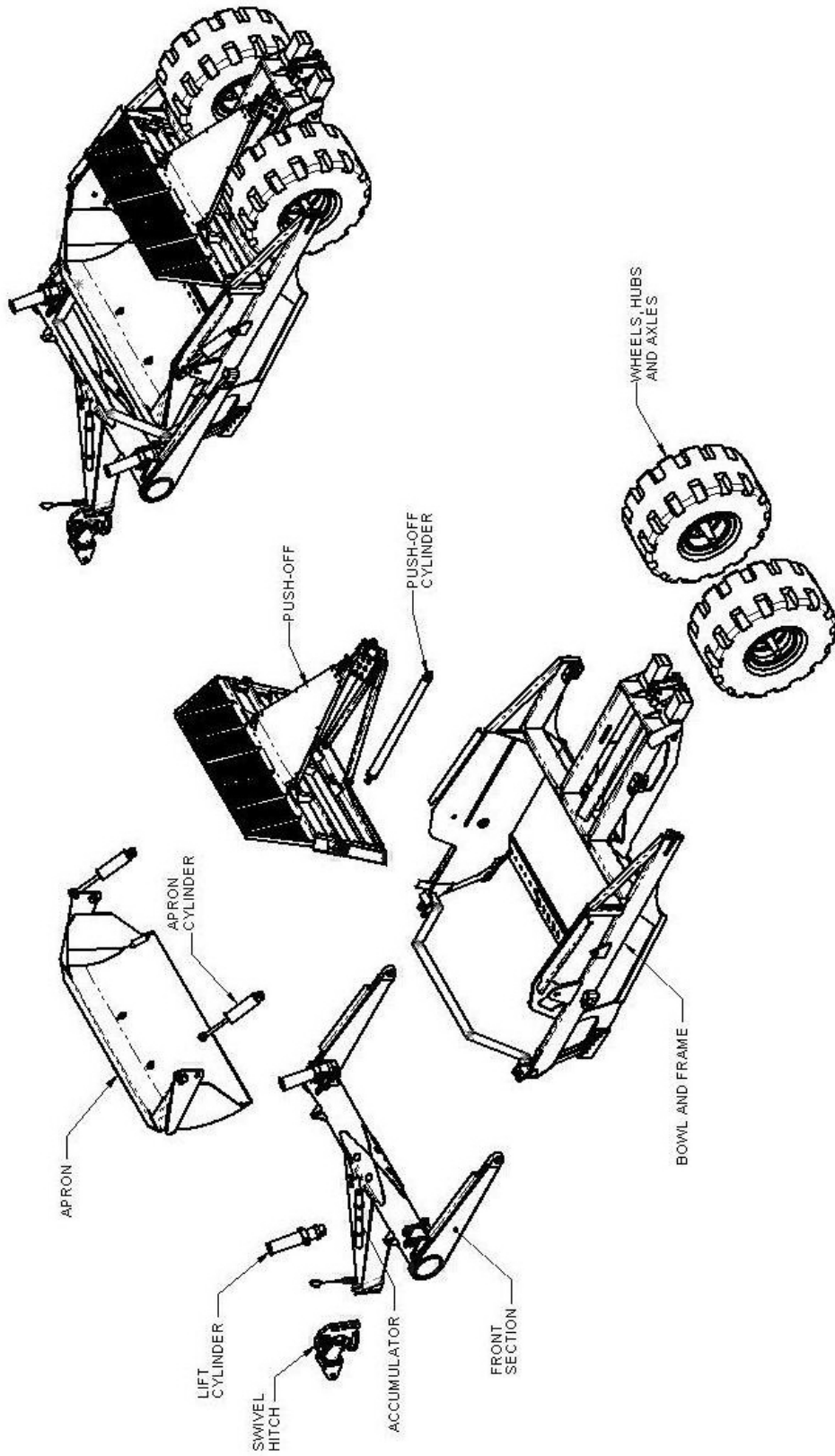

I-180TS2 BRAKE

Icon Swivel Hitch Part # A125224

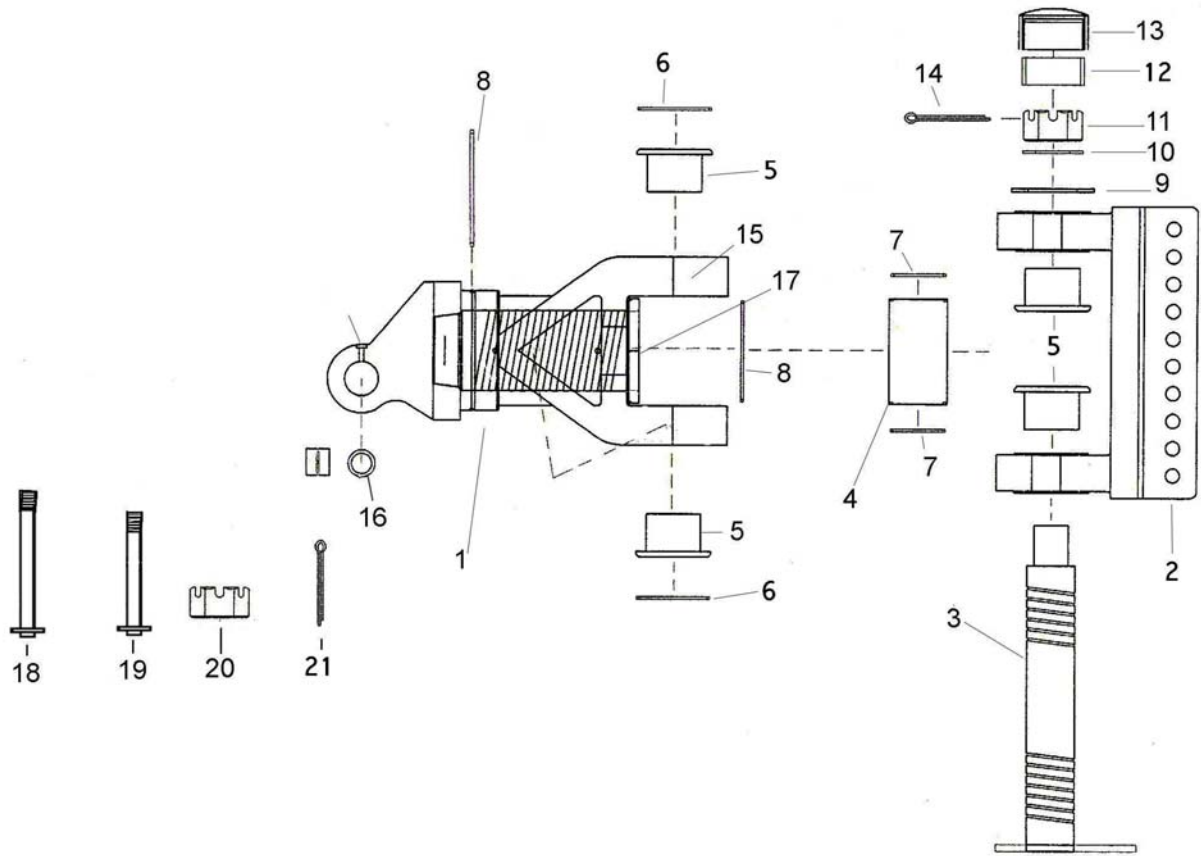

A-125224-ILL

Key Number	Part Number	Description
1	A125224-01	Yoke: A-Frame swivel
2	A125224-03	Bracket: 10 Hole
3	A125224-04	Pin: Main Vertical
4	A125224-05	Spacer: 6"
5	A125224-07	Bushing
6	A125224-08	Seal: O-ring
7	A125224-09	Seal: O-ring
8	A125224-10	O-ring
9	A125224-13	Spacer: 6"
10	A125224-14	Washer: 2 1/2"
11	A125224-15	Nut: Slotted 2-1/2" NC
12	A125224-16	Sleeve: 2" Rubber
13	A125224-17	Cap: For Vertical Pin
14	A125224-18	Pin: Cotter 3/8 x 5"
15	14505	Grease Fitting Straight
16	A125057-02A	Bushing
17	AHF-00027	Zerk 45°
18	A123299-08	Pin: Four Ear Drawbar to Hitch 1 1/2" X 15 5/8" L
19	A123299-07	Pin: Two Ear Drawbar to Hitch 1 1/2" X 12 5/8" L
20	AFN-00014	Nut: 1 1/2" Slotted
21	AFP-00001	Pin: Cotter 1/4 X 3

I-180TS2 BRAKE

Front Section Frame

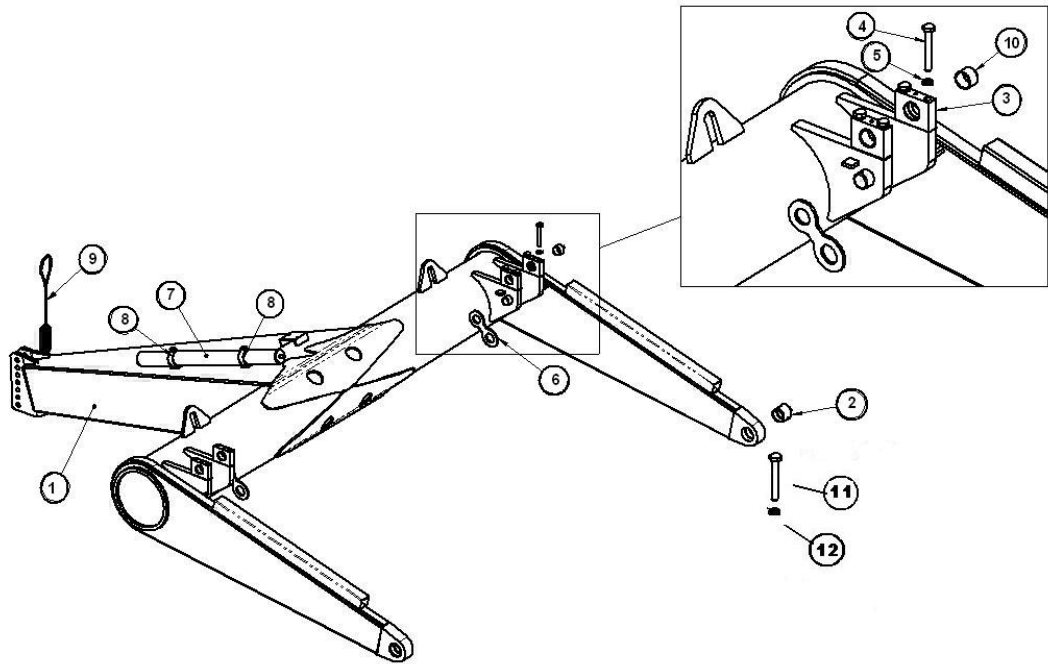

Key Number	Part Number	Description
1	A123320	Front Section
2	A123320-08	3" ID x 3-1/2" OD x 3" long bronze bushing
3	A123456	Trunion mount block
4	AFB-00039	"Bolt, 3/4" NC x 5-1/2" long, gr. 8"
5	AFW-00002	3/4" lock washer
6	A123320-20	Travel Lock
7	A125005	Accumulator
8	A125009	Mounting brackets
9	A125109A	Hose Support
10	A125179	Trunion Bushing
11	AFB-00021	1x5-1/2 NC Gr 8 Bolt
12	AFN-00037	1" NC Locknut

I-180TS2 BRAKE

Lift Cylinder 5 1/2" X 20" Part No. A125044

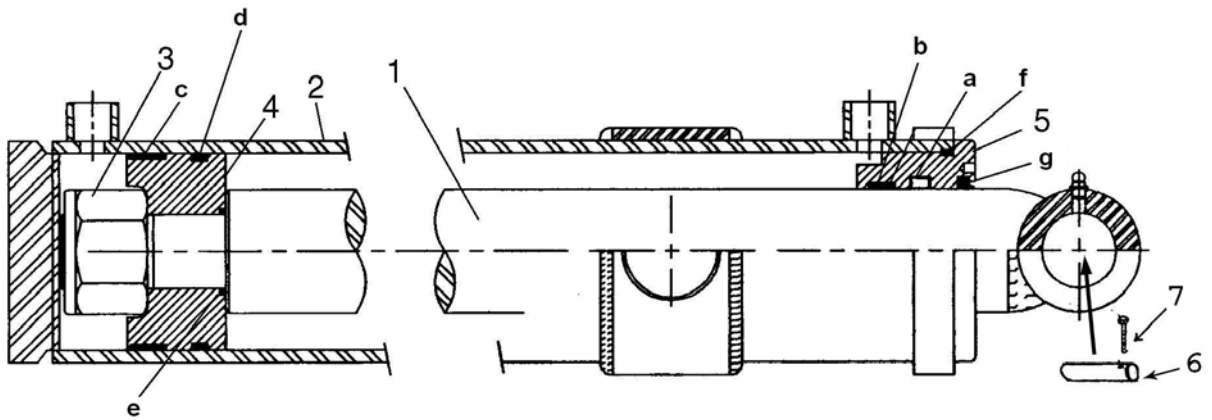

Lift Cylinder

A-123326-III

Key Number	Part Number	Description
1	A123326-1	Piston Rod: 2-1/2"
2	A125044-02	"Barrel Weldment, 5-1/2"
3	A125159-34	1-3/4 NF Locknut
4	A125044-04	"Piston, 5-1/2"
5	A125044-05	"Gland, 5-1/2"
6	A123335	Pin, 2" X 10 1/2" Lg.
7	AFP-00001	Cotter Pin, 1/4" X 3"
	A125044-40	Seal Kit (Items a-g)
a	A123324-6	Rod Seal
b	A123324-3	Wear Band ID for Gland
c	A125044-10	"Wear Ring, 5-1/2"
d	A125044-15	"Piston Seal, 5-1/2"
e	A123324-10	"O-Ring, ID of Piston"
f	A125044-20	"O-Ring, OD of Gland"
g	A123324-7	Rod Wiper

I-180TS2 BRAKE

Apron Assembly Part # A123322

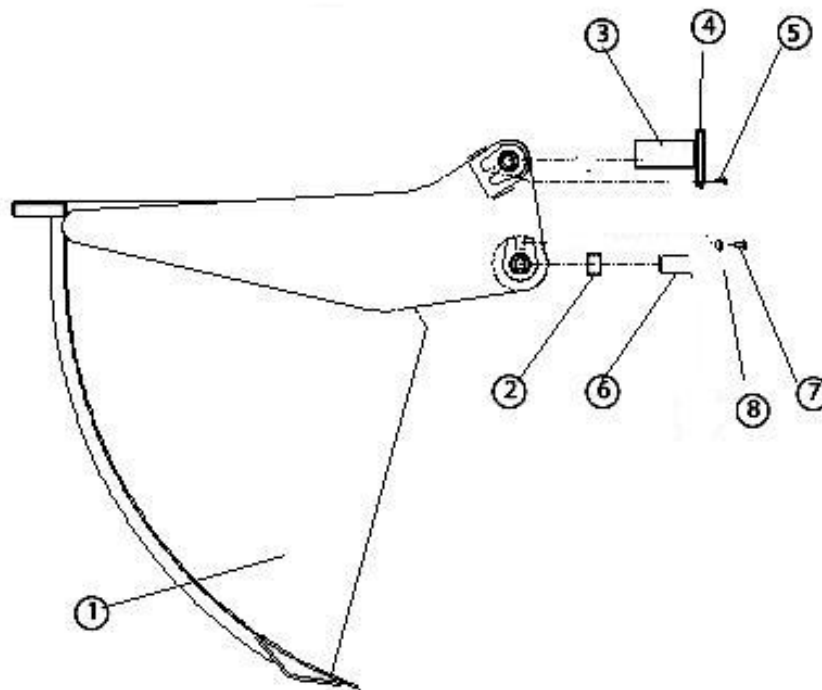

A-123322-III

Key Number	Part Number	Description
1	A123322	Apron Model I-180-TS
2	A125249	Bushing 2" ID Ball Swiv. w. Graph. Plugs
3	A123322-14	"Pin: 2" x 3-3/4" long, For Apron cyl rod end"
4	A123358	Flanged Bolt Bushing
5	AFB-00079	Bolt: 5/8" X 1 1/2"
6	A123321-113	Apron Pivot Pin w/grease zerk
7	AFB-00012	1/2" Bolt 1/2 X 4 1/2"
8	750500	1/2" lock nut

I-180TS2 BRAKE

Apron Cylinder A125257

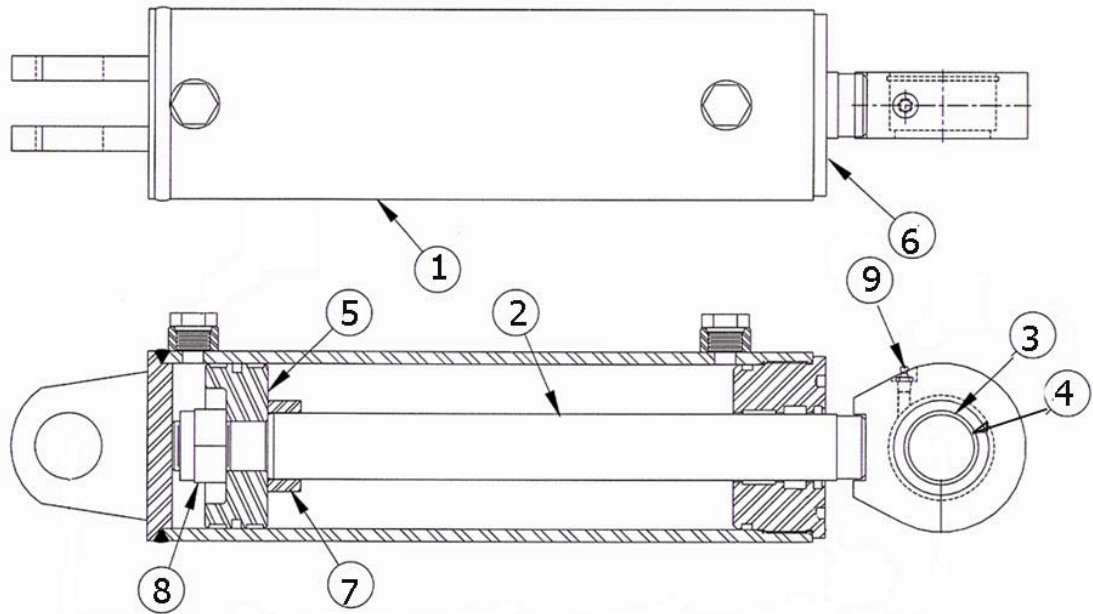

M180TV350P001

Key Number	Part Number	Description
1	A125257-10	Barrel Weldment
2	A125257-20	Rod
3	A125257-35	Bushing
4	A125057-36	Snap Ring
5	A125257-30	Piston
6	A125257-31	Head
7	A125257-32	Spacer
8	A125257-33	1 1/2" Toplock Nut
9	14505	Grease Zerk
	A125257-40	Seal Kit

I-180TS2 BRAKE

Bowl & Frame Assembly Illustration

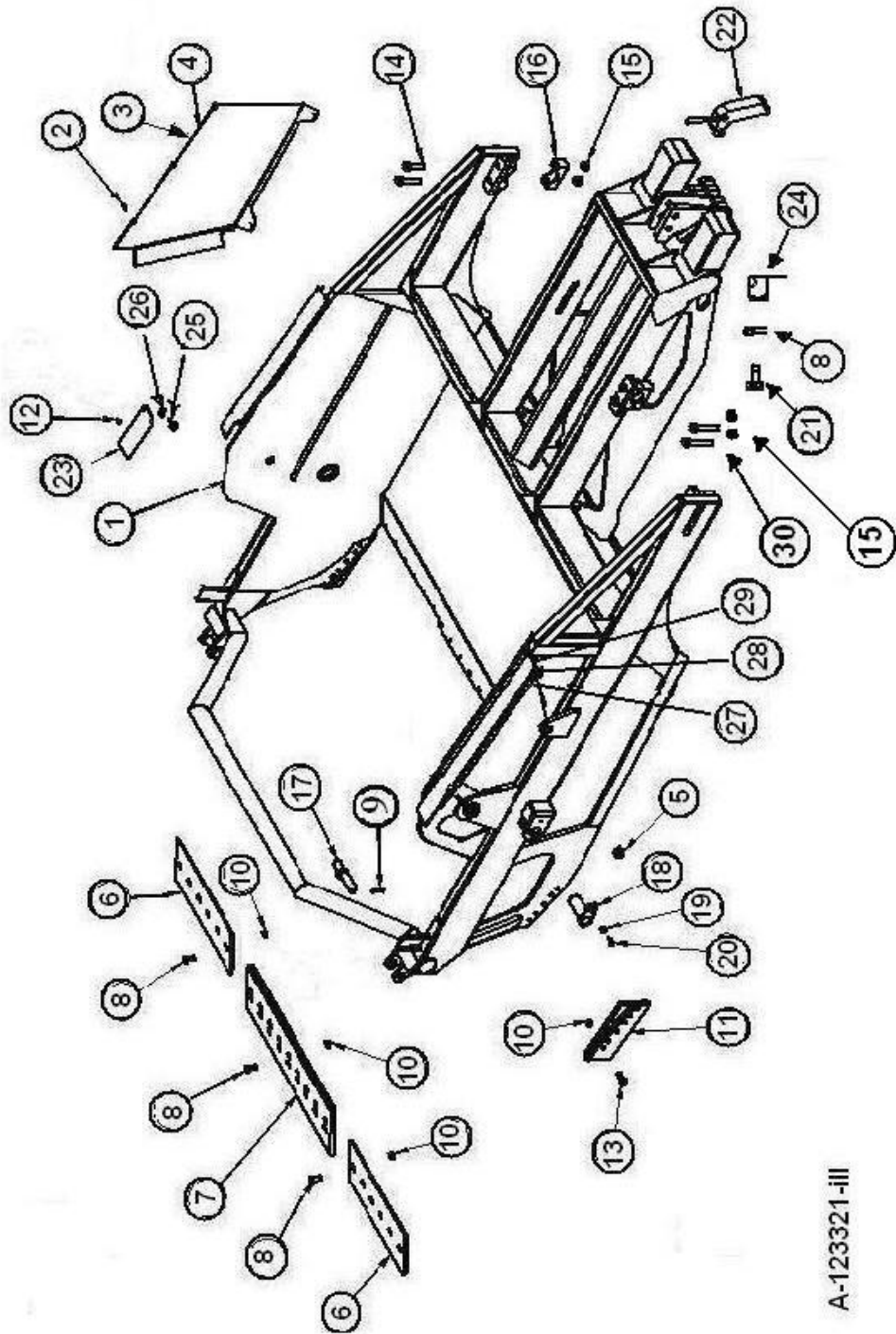

A-123321-III

I-180TS2 BRAKE

Bowl & Frame Assembly Parts I-180TS2

Key Number	Part Number	Description
1	A123321	Bowl and frame assembly
2	AFB-00094	Flanged Bolt: 3/8" NC x 1" long
3	A123369-1L	Left side dirt shield
4	A123369-1R	Right side dirt shield
5	A125018	Bushing: 2-3/8" OD x 2" ID x 1-1/4 Lg
6	A125103	"Left & Right Straight Corner Blade
7	A125072*	"Center blade, 18" Straight, reversible"
	A125072-SER*	"Center blade, 18" dbl serrated, reversible"
8	PB1P-NC-100-0275	Plow bolt: 1" NC x 2-3/4" long
9	AFP-00001	Cotter Pin
10	AFN-00012	Nut: 1" NC
11	A123357	"Bank shaver/router bit, reversible, L & R"
12	AFB-00027	Bolt: 3/8 X 1 1/2
13	AFB-00018	Bolt: 1" NC x 3" long (5 per router blade)
14	AFB-00109	Bolt: 1-1/4" NF x 9" long (9)
15	AFN-00032	Nut: 1-1/4" NF
16	A123321-65	Axle mount
17	A123335	Lift cylinder pin
18	A123321-09	Main frame pin
19	A123358	Flanged bolt bushing
20	AFB-00079	Bolt: 5/8" x 1 1/2" long
21	A123321-98	Pins
22	A123321-89	Pin Keeper
23	A123369-13	Dirt Shield Flap
24	A125006	Safety Snap Pin 1/4 x 2-1/4 with sq retainer
25	7450	3/8 NC Nut
26	AFW-00010	3/8 Flat Washer
27	A125020	3/2" Grease Line
28	A125026	3/8 NF Bulkhead Nut
29	A125019	Grease Fitting 1/4 - 28 X 54" L
30	AFB-00122	Bolt: 1 1/4 NF X 10" Gr. 8

I-180TS2 BRAKE Pushoff Assembly Illustration

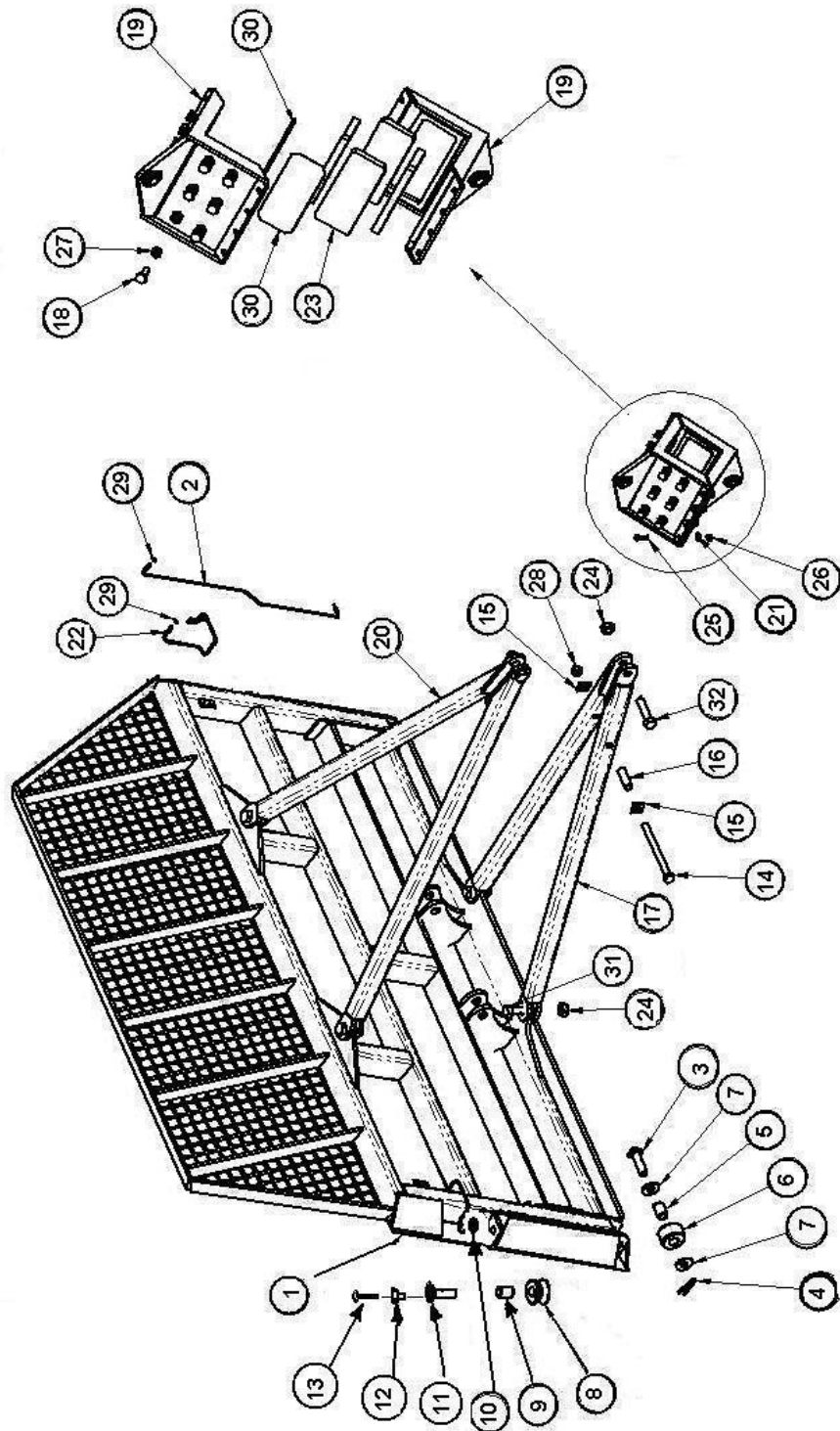

I-180TS2 BRAKE

Pushoff Assembly Parts

Key Number	Part Number	Description
1	A123323	Pushoff Assembly
2	A125023	Grease line, Outside floor roller 48"
3	A123323-21	Pin: 1-1/4" x 4-1/8" long
4	AFP-00001	Cotter Pin: 1/4" x 3"
5	A10163	Bushing: 1-3/4" O.D. x 1-1/4" I.D.
6	A10164	Roller
7	AFW-00015	Washer
8	A123323-24	Roller
9	A123323-24B	Bushing: 2 ID X 2.5 OD
10	A123323-09	Spacer
11	A123323-23	Pin: Upper Roller 2 x 7 7/8
12	A123358	Pin Keeper
13	AFB-00079	Bolt: 5/8" x 1 1/2"
14	AFB-00103	1 x 12 Bolt
15	AFW-00019	Wedge Washer
16	A123323-48	Wedge Spacer
17	A123323-35	Bottom Support
18	AFB-00060	Bolt: 3/4" NF x 2" long
19	A123364	Slide Guide Box
20	A123323-36	Top Support
21	8110	5/8 Lock Washer
22	A125022	"Grease line, hold down roller 18"
23	A123364-08	Plastic slide
24	AFN-00009	1 1/4 NF Locknut
25	6684	5/8 x 2 NC gr. 8 Bolts
26	7530	5/8 NC gr. 8 Nuts
27	AFN-00023	JamNut: 3/4" NF
28	AFN-00001	NF Nut Lock 1" NF
29	A125026	Bulk Head Nut
30	A123364-3	Shim Plate
31	AFB-00076	Bolt: 1 1/4 NF X 4
32	AFB-00075	Bolt: 1 1/4 NF X 5

I-180TS2 BRAKE

Pushoff Cylinder 4" Bore x 60" Stroke Part No. A125178

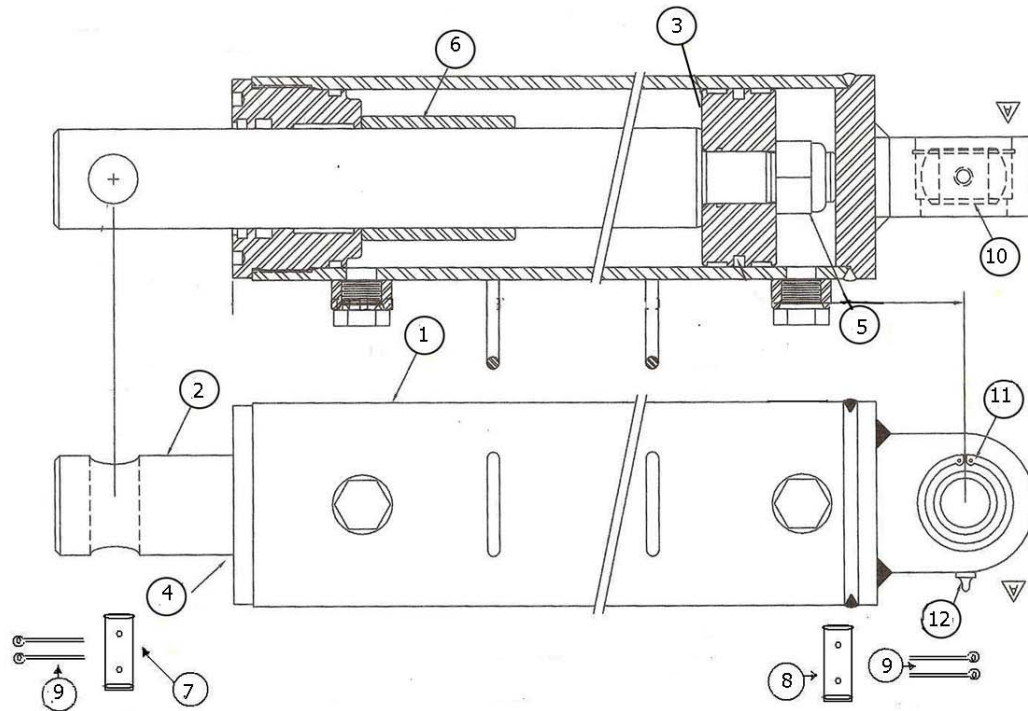

A125178

M180TV350P002

Key Number	Part Number	Description
1	A123360-01	Barrel
2	A123360-02	Rod
3	A123360-03	Piston
4	A123360-04	Head Gland
5	A123360-05	Lock Nut
6	A123360-07	Spacer Sleeve
7	A123323-38	Rod End Pin 5-1/16 x 1-1/2
8	A123323-41	Barrel End Pin 4-9/16 x 1-1/2
9	AFP-00001	1/4 x 3 Cotter Pin
10	A125178-35	Bushing
11	A125178-36	Snap ring
12	14505	Grease Fitting 1/8 NPT st
	A123360-16	Seal Kit

I-180TS2 BRAKE

Wheel Assembly With Brake

Updated Wheel Assembly with Split Brake Mount/clamp and caliper and pads.

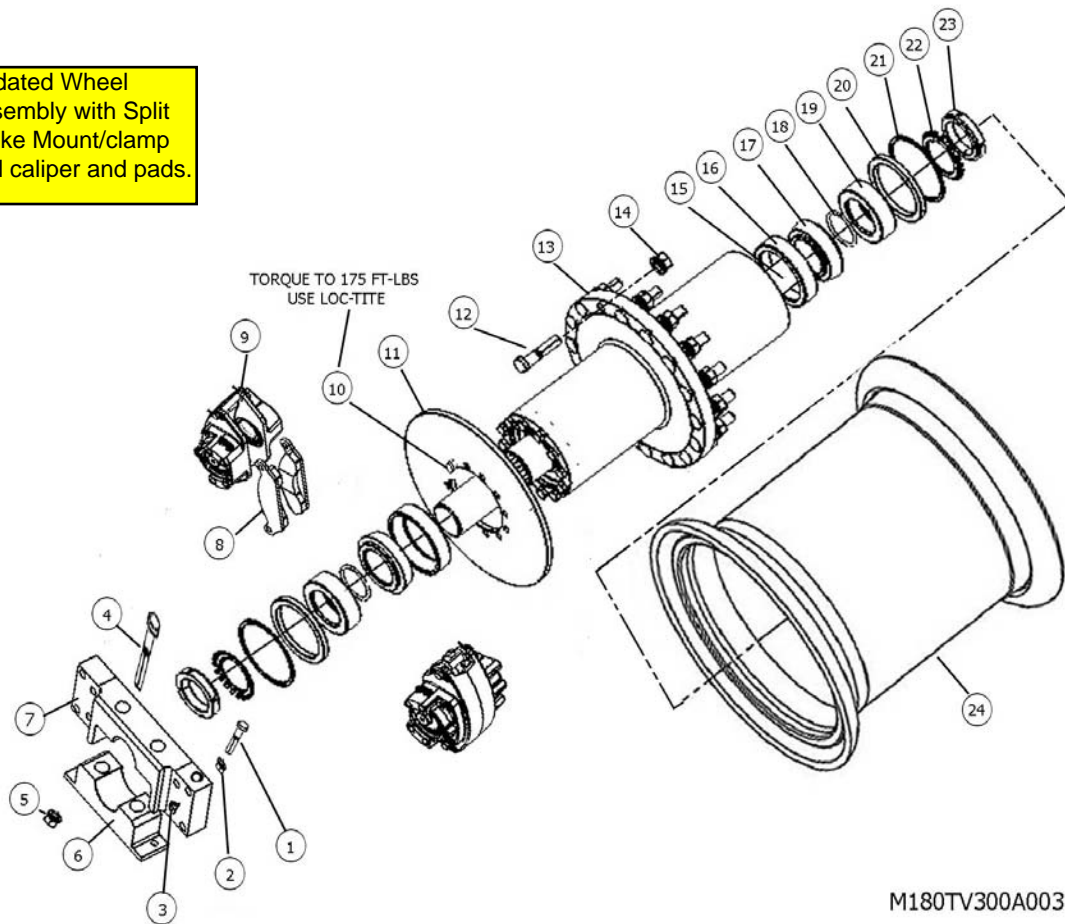

M180TV300A003

Key Number	Part Number	Description
1	AFB-00018	1 X 3 lg. bolt
2	AFN-00012	Nut: 1" NC Gr 8
3	AFB-00117	Bolt: M20 X 2.5
4	AFB-00122	Bolt: 1 1/4 nf X 10"
5	AFN-00032	Nut: Jam 1 1/4" NF
6	500448	Mount Clamp: Lower Half
7	500447	Mount: Brake Top Half
8	A125225-01	Brake Pad
9	A125225	Brake Caliper
10	6684	Bolt: Hex head
11	A125228	Brake Rotor 19" OD
12	A125237	Stud: M22 X 1.5
13	500320	Hub: I180TS
14	A125229	Wheel Nut: 22mm
15	500319	Axle: 180TS
16	A125017	Bearing: Outer Cup I-180TS
17	A125016	Bearing: Outer Cone I-180TS
18	AHS-00148	Seal: O-ring
19	500327	Spacer: Bearing I180TS
20	A125232	Seal: Grease
21	A125235	Ring: Retaining
22	A125234	Washer: Tab Lock 180
23	A125233	Locknut: Spindle 180
24	500318	Wheel: 25" X 25"

I-180TS2 BRAKE

Brake Replacement Directions

- 1.) Secure Scraper on stands with wheels 1-2" off of ground & chock wheels.
- 2.) Remove Axle Retaining Bolts from Axle Mounting Pads. Retain Outside Lower Axle Clamp Block. Inside Upper and Lower Axle Clamp Blocks will be replaced.
- 3.) Carefully remove Wheel Assembly from Scraper Rear Frame and secure.
- 4.) Clean Exposed Wheel, Hub and Axle surfaces on the Brake Side (side closest to center of scraper, where Hub end face has (12) 5/8" Hex Head Cap Screws installed).
- 5.) Remove (12) 5/8" Hex Head Cap Screws from face of Hub. Clean Anti-Seize from tapped holes in Hub Face.
- 6.) Slide Entire Brake Kit onto Axle Shaft until Rotor contacts Hub face.
- 7.) Align Rotor mounting holes with Hub face tapped holes. Apply Supplied Loc-Tite 262 to Supplied 5/8" Cap Screws and fasten Rotor to Hub. Sequentially torque (12) 5/8" cap screws to 175 ft-lb. (Item 22, page 18)
- 8.) Adjust Caliper Mounting Block to center Calipers on Rotor (Item 7 & 7a, page 18)
- 9.) Rotate Axle, Caliper Mount and Calipers to ensure smooth operation.
- 10.) Install Wheel Assembly into Scraper Rear Frame. Replace Axle Retaining Bolts and torque to 400 ft-lb.
- 11.) Loosen Caliper Stop Bolt Jam Nut (Item 1, page 18), Tighten Caliper Stop Bolt until it contacts Caliper Mount Block and Lock Jam Nut.
- 12.) Remove Brake Line Cap Plug and connect Caliper Brake Lines.
- 13.) Repeat Procedure for opposite Wheel Assembly.
- 14.) Bleed Brake Calipers, One Piston at a time per Caliper.
- 15.) Test Brake Operation, Bleed if Required.

I-180TS2 BRAKE

IMPORTANT: This Hyd. Manifold was integrated into production April, 2006 It replaces A125070 valve.

For older machines see master parts book on Ashlandind.com.

HYDRAULIC MANIFOLD ASSEMBLY

A125174

SETTING THE APRON AND PUSHOFF VALVE

The manifold block containing the pushoff sequence valve cartridge and apron sequence valve cartridge is used to control two hydraulic circuits with one hydraulic remote. When the tractor hydraulic remote is activated, oil flows first to the apron cylinders until they are fully extended. Once the cylinders are fully extended, the apron circuit's hydraulic pressure begins to increase. Once the pressure threshold is surpassed (which is adjustable, see adjustment section), the sequence valve diverts the oil flow to the pushoff's hydraulic circuit. Once the push off is completely extended, the operator then reverses the tractor's hydraulic remote. The counterbalance valve will hold the apron open until the push off is fully retracted. The Apron sequence valve then opens and allows the apron to close.

Setting the valves:

STEP 1 PUSHOFF SEQUENCE VALVE

Loosen the lock nut (9/16") on the sequence valve cartridge. Turn the setscrew (4mm) clockwise until the front apron rises before the push-off begins to advance. (Earthmover should be empty) Turn the adjustment screw an additional 1/4 turn clockwise and tighten jam nut.

STEP 2 Counter Balance VALVE

Loosen the lock nut (9/16") on the counterbalance valve cartridge. Turn the setscrew (4mm) counter-clockwise until the apron holds in a raised position while rear gate is being retracted. Turn adjustment screw an additional 1/4 turn, tighten jam nut. DO NOT tighten adjusting screw more than necessary.

Hydraulic Manifold Assembly



Key Number	Part Number	Description
1	A125162-01	COUNTER BALANCE CARTRIDGE
2	A125162-02	SEQUENCE CARTRIDGE

I-180TS2 BRAKE

Hydraulic Valve Assembly Ports

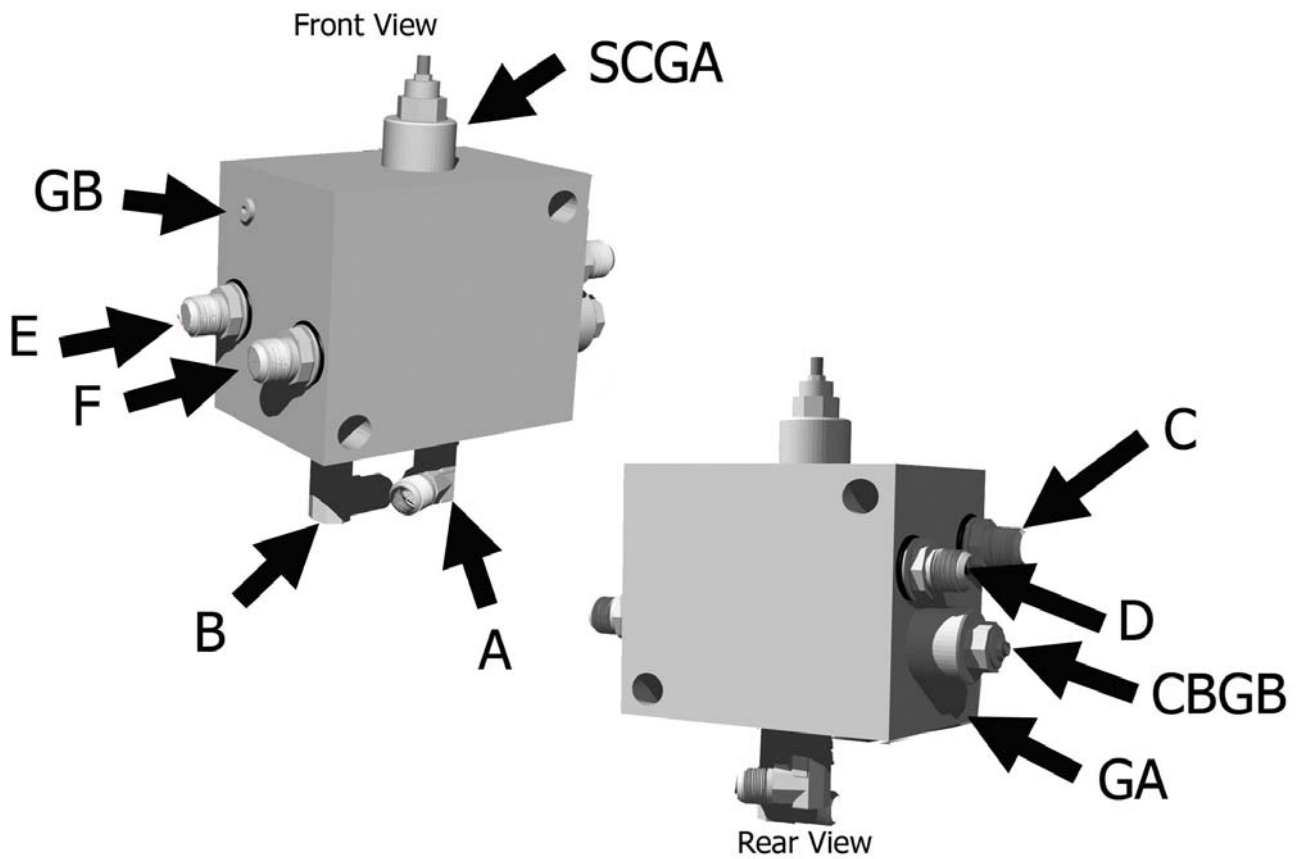

The lettering for the port locations are stamped on the block

A125174 Port Locations.ILL

Key Number	Description
A	Supply Line
B	Pushoff Cyl., (Rod End)-Apron Cyl., Right side (Base End)-Supply Line
C	Pushoff Cylinder, (Base End)
D	Apron Cylinder, Right side, (Rod End)
E	Apron Cylinder, Left side (Base End)
F	Apron Cylinder, Left side, (Rod End)
CBGB	Counterbalance Valve, adjustable
SCGA	Sequence Valve, adjustable
GA	Pressure test port
GB	Pressure test port

I-180TS2 BRAKE

Hydraulic Schematic

I-180TS2 HYDRAULIC SCHEMATIC

TRACTOR

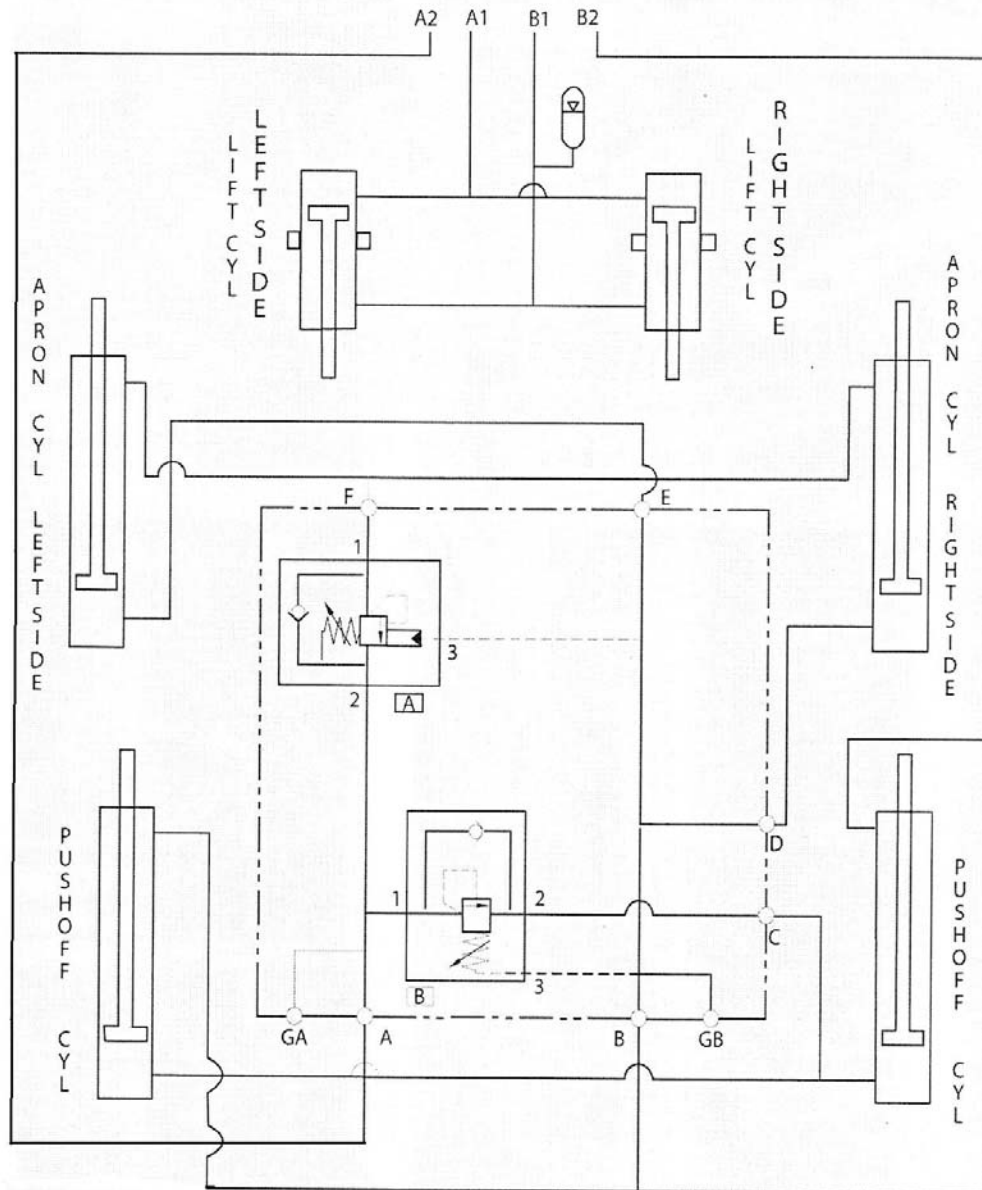

PORT GA AND GB are pressure test ports

ⓐ - Counter balance cartridge

ⓑ - Sequence cartridge

I-180TS2 BRAKE

Hydraulic Schematic Brake

Added Hydraulic Schematic for Brake

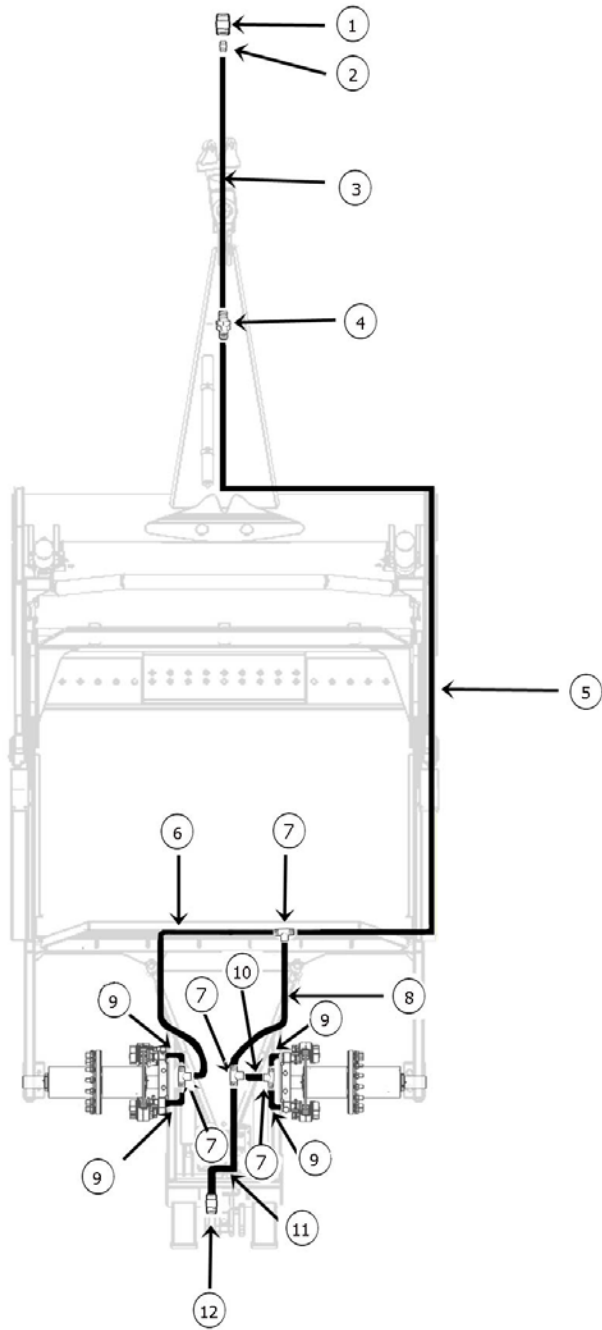

M180TV400H017

Key Number	Part Number	Description
1	A125231	Coupler, Female Half
2	AHA-00088	Adapter
3	A125262	Hose: Front Bulk Head
4	AHA-00095	Adapter
5	A125263	Hose Assembly-Bowl
6	A125266	Hose: Brake Line to Caliper (L)
7	AHA-00089	Adapter
8	A125264	Hose: Brake Line (R)
9	A125267	Hose: Caliper (R & L)
10	A125265	Hose: Brake Caliper (R)
11	A125268	Hose: Rear Bulkhead Coupler
12	A125230	Coupler: Male Half

I-180TS2 BRAKE

Grease Locations

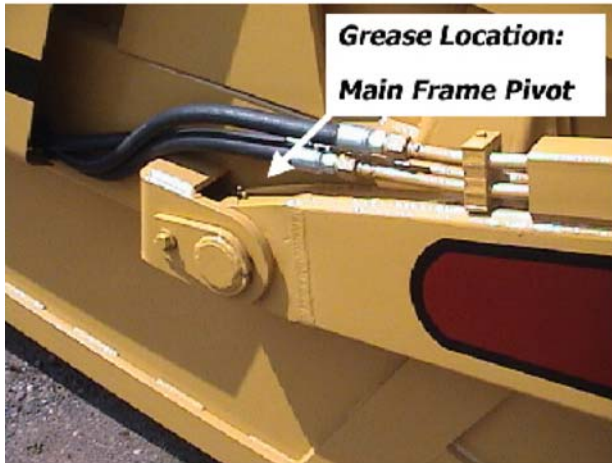
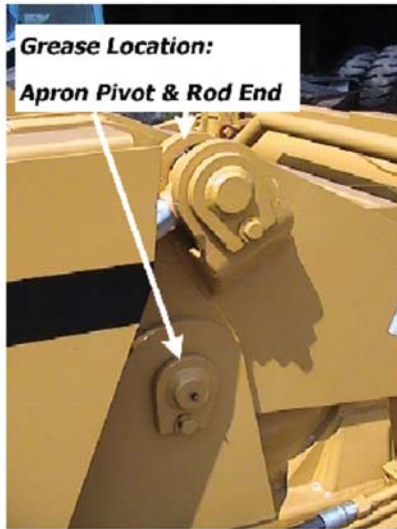

180-Grease-2-ILL

I-180TS2 BRAKE

MAINTENANCE CHECKLIST

1. Grease all zerks.
 - a) Every 8 hours of operation.
 - b) See Lubrication Points section on next page.

2. Greasing the hubs.
 - a) Re-pack wheel bearings after 600 hrs of operation.
 - b) Completely clean grease out of hub and bearings every 1200 hours of operation.

3. Check tire pressure.
 - a) 29.5 x 25 28 ply tire requires a tire pressure of 45-50 psi.

4. Check all pins for signs of wear.
 - a) Daily

5. Check wheel lug nut torque.
 - a) After first 2 hours of operation.
 - b) Recheck daily for next 2 weeks.
 - c) Tighten wheel lug nuts in a star pattern.
 - d) Torque wheel lug nuts to 450 ft-lbs.

6. Check and retighten all bolts.
 - a) After initial 10 hours of use.
 - b) Again after 50 hours of use.
 - c) See Torque Specifications on next page.

7. Inspect cutting edges.
 - a) Daily
 - b) Replace cutting edges when center blade has been worn to approximately 6" and side edges worn to approximately 4".



CAUTION! Failure to replace worn cutting edges may result in unnecessary wear to the earthmover sides and floor.

Note: Left or right side parts are determined by viewing from rear of the scraper.

I-180TS2 BRAKE

TORQUE SPECIFICATIONS

<i>Bolt Diameter</i>	<i>Torque Ft-lbs</i>
<i>1/4</i>	<i>12</i>
<i>5/16"</i>	<i>25</i>
<i>3/8"</i>	<i>45</i>
<i>7/16"</i>	<i>70</i>
<i>1/2"</i>	<i>110</i>
<i>9/16"</i>	<i>150</i>
<i>5/8"</i>	<i>220</i>
<i>3/4"</i>	<i>380</i>
<i>7/8"</i>	<i>600</i>
<i>1"</i>	<i>900</i>
<i>1-1/8"</i>	<i>1280</i>
<i>Lug Nuts</i>	<i>750</i>

LUBRICATION

1. Grease all zerks every 8 hrs of operation with high quality, general-purpose grease.
 - a) Grease until grease flows from around pin.

Lubrication Points (see III.)

1. Hitch – Horizontal and vertical pins.
2. Lift Cylinders – Rod end & Trunion; Both left & right sides.
3. Front Arm Pivot Joint – Both left & right sides.
4. Apron Cylinders – Rod clevis pin; Both left & right sides.
5. Apron Pivot Pin – Both left & right sides.
6. Hold-down Rollers – Both left & right sides.
7. Floor Rollers – Both left & right sides.

I-180TS2 BRAKE

Warning: Tire

WARNING



Check Tires and Wheels

The task of servicing tires and wheels can be extremely dangerous and should be performed by trained personnel only, using the correct tools and following specific procedures. Do not attempt to mount, demount or inflate a tire if you do not have the proper equipment and experience to perform the job. Call a qualified repair service to inspect the assembly and make necessary repairs. Failure to heed warnings could lead to serious injury or death.

Visually inspect tires and wheels daily. Carefully inspect any rim and tire assembly that has been run underinflated or flat before reinflating the tire to make sure there is no damage to either the rim or tire.

- ALWAYS wear personal protection equipment such as gloves, footwear, eye protection, hearing protection and head gear when servicing tire and wheel components.
- DO NOT operate with damaged rims, tire cuts or bubbles, missing lug bolts or nuts or damaged rims.
- ALWAYS maintain the correct tire pressure. NEVER exceed recommended tire inflation pressure.
- INSPECT any rim and tire assembly that has been run flat or severely underinflated before reinflating the tire. Damage to the rim and tire may have developed.
- NEVER inflate a tire that has lost air pressure or has been run flat without determining and correcting the problem.
- NEVER try to repair wheel, rim, or tire components parts. Parts that are cracked, worn, pitted with corrosion, or damaged must be discarded, and replaced with good parts.
- ALWAYS use approved tire and rim combinations for the model scraper that you have and verify that part numbers of components are correctly matched for the assembly.
- ALWAYS exhaust all air from the tire prior to demounting.
- ALWAYS place wheel and tire assemblies in restraining devices (safety cage) when inflating tires. Use a clip-on chuck and long extension hose to allow you to stand to the side of the tire and not in front of it.
- NEVER weld or cut on an inflated tire assembly. Welding heat can cause increased pressure which could result in tire explosion.
- ALWAYS use proper lifting techniques, and mechanized lifting aids to move heavy components and assemblies.
- NEVER leave a tire, wheel, or assembly unsecured in a vertical position.
- ALWAYS take care when moving tires and wheels that other people in the area are not endangered.

I-180TS2 BRAKE

TROUBLESHOOTING

Introduction

With proper care and maintenance, the I-180TS will give many years of reliable service. When a situation arises where the earthmover performance is not satisfactory, this section will give some pointers on finding and correcting the problem.

Grease zerk will not take grease.

1. Grease zerk plugged.
 - a) Remove and replace grease zerk.
 2. Pin is frozen.
 - a) Remove, clean, and inspect pin.
 - b) Replace pin if necessary.
 3. Bushing grease passage is not aligned with grease zerk.
 - a) Remove, clean, inspect, and realign bushing.
 - b) Replace bushing if necessary and realign.
-

Push-off rollers do not roll.

1. The rollers need lubrication.
 - a) Check zerk hole and grease.
 - b) Remove pin, clean, inspect, and replace if necessary.
 2. The roller bushing is worn out.
 - a) Remove roller assembly and replace bushing.
 - b) See parts manual.
-

Cylinders will not hold in preset position, i.e. the cylinder creeps.

1. Seals leaking internally.
 - a) Remove and replace seal kit.
-

Machine cuts unevenly.

1. Cutting edges worn unevenly.
 - a) Replace cutting edges.
2. Improperly inflated tires.
 - a) Check air pressure in tires.

Limited Warranty Statement

Ashland Industries Inc. warrants each new product to be free from defects in material and workmanship. This warranty is applicable only for the normal service life expectancy of the product or components, not to exceed **six consecutive months** from the date of delivery of the new Ashland Industries product to the purchaser, or the date the product is first put into service via a rental agreement or other means, whichever occurs first.

The major components of swivel hitches used on Industrial series scrapers are warranted for three consecutive months from the date of delivery of the new Ashland Industries product to the purchaser, or the date the product is first put into service via a rental agreement or other means, whichever occurs first, except those components described below.

Genuine Ashland Industries Inc. replacement parts and components will be warranted for 30 days from date of purchase, or the remainder of the original equipment warranty period, whichever is longer.

Under no circumstances will it cover any merchandise or components thereof, which in the opinion of the company, has been subjected to misuse, unauthorized modification, alterations, an accident or if repairs have been made with parts other than those obtained through Ashland Industries Inc.

Ashland Industries Inc. in no way warrants Tires since their respective manufacturer warrants these items separately. Please call Ashland Industries Inc. to receive phone numbers of tire suppliers.

Ashland Industries Inc. in no way warrants wearable items such as cutting edges, front dolly wheel balls, socket halves, rollers, bushings, yoke hitch pins, hitch bushings, etc..

Our obligation under this warranty shall be limited to repairing or replacing, free of charge to the original purchaser, any part that, in our judgement, shall show evidence of such defect, provided further that such part shall be returned within 30 days from the date of failure to Ashland Industries Inc. routed through the dealer and distributor from whom the purchase was made, transportation charges prepaid. Upon warranty approval proper credits will be reimbursed for transportation.

This warranty shall not be interpreted to render Ashland Industries Inc. liable for injury or damages of any kind or nature to person or property. This warranty does not extend to the loss revenue, extra labor cost associated with downtime, substitute machinery, rental or for any other reason.

Except as set forth above, Ashland Industries Inc. shall have no obligation or liability of any kind on account of any of its equipment and shall not be liable for special or consequential damages. Ashland Industries Inc. make no other warranty, expressed or implied, and, specifically, Ashland Industries Inc. disclaims any implied warrant or merchantability or fitness for a particular purpose. Some states or provinces do not permit limitations or exclusions of implied warranties or incidental or consequential damages, so the limitations or exclusion in this warranty may not apply.

This warranty is subject to any existing conditions of supply which may direct affect our ability to obtain materials or manufacture replacement parts.

Ashland Industries Inc. reserves the right to make improvements in design or changes in specifications at any time, without incurring any obligation to owners of units previously sold

No one is authorized to alter, Modify or enlarge this warranty nor the exclusion, limitations and reservations.

Ashland Industries Inc.
Warranty Department