

Ashland

EARTHMOVERS

I-180TS2

PARTS MANUAL

Ver. 0909-22209



180-III

Ashland Industries Inc.
1115 Rail Drive
P.O. Box 717
Ashland, WI. 54806
877-634-4622 Toll Free - phone
715-682-4622 phone
715-682-9717 fax
www.ashlandind.com

MEMBER



CONSTRUCTION INDUSTRY
MANUFACTURERS ASSOCIATION



IMPORTANT

Please locate red Transport Links and remove prior to operation. Retract Lift Cylinder Circuit, Remove Safety Snap Pin, Remove link and replace into storage position as shown in figure 2. Do not use Transport Locks until scraper is completely empty of soil.

Reinstall Safety Snap Pins.

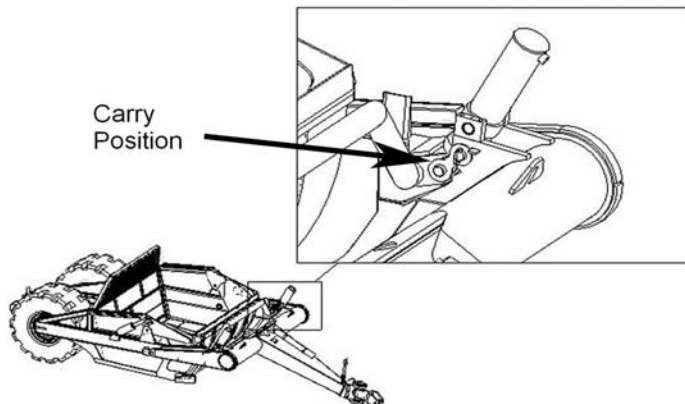

Storage
Position

Figure
2

I-180TS2

How to Order Parts



HOW TO ORDER PARTS:

IMPORTANT

Parts must be ordered through your local authorized ASHLAND dealer.

Be sure to state MODEL and SERIAL NUMBER of your machine, PART NUMBER, DESCRIPTION and QUANTITY needed.



Unless this is done, we cannot provide prompt service or assure shipment of the correct parts.

Ashland Industries weldable replacement parts are available to rebuild, modify or update your scraper to current factory specifications.

Index

Page 4.	Operators and Maintenance Instructions
Page 5.	Safety Guidelines
Page 6.	Illustration – Assembly
Page 7.	Complete Yoke Type Hitch
Page 8.	Front Section Frame
Page 9.	Lift Cylinder 5 ½ X 20
Page 10.	Apron Assembly
Page 11.	Apron Cylinder
Page 12.-13.	Bowl and Frame Assembly
Page 14.-15.	Pushoff Gate Assembly
Page 16.	Push Off Cylinder
Page 17.	Wheel and Brake Assembly
Page 18.	Hydraulic Valve-Identification, Illustration, Parts List and Adjustment
Page 19.	Hydraulic Schematic
Page 20.	Grease Locations
Page 21.-25.	Service Manual Appendix
Page 26.	Warranty Statement

I-180TS2

Operators and Maintenance Instructions

OPERATORS AND MAINTENANCE INSTRUCTIONS

This scraper is a durable piece of equipment and with proper care will yield many years of trouble free operation. The scraper requires a power source with TWO 4 way (double acting) hydraulic control valves.

The scraper should be greased at all points where grease fittings are provided.



Connect hydraulic hoses to the tractor and retract lift cylinders to **REMOVE TRANSPORT LOCK PINS**, then extend and retract all cylinders several times to force out any air from the hydraulic cylinders and lines. Check the oil levels in the tractor hydraulic system and add to maintain the proper level. Care should be used when adding oil or when disconnecting any oil line to keep all dirt out of the oil as dirt is a major factor in the failure of hydraulic components.

When the scraper is placed into operation, the operator will have to “feel out” the amount of depth of cut to obtain maximum loading efficiency. This is usually accomplished by taking a lesser and more uniform cut; however, some soil conditions such as loose sand may require a “pumping action” obtained by taking successive deep cuts and lifting out of cut as the tractor begins to lose power or traction.

1. After 10 hours work, all bolts should be checked and tightened if necessary.
2. Every 10 hours all grease fittings should be lubricated.
3. After 50 hours work, all bolts should be rechecked and tightened if necessary. Check wheel bearings and adjust if necessary.
4. After 300 hours work, clean and repack wheel bearings and replace, if necessary, cutting edges, worn pins, etc.

I-180TS2

Safety Guidelines



SAFETY SIGNAL WORDS

Note the use of the signal words DANGER, WARNING and CAUTION with the safety messages. The appropriate signal word for each has been selected using the following guidelines:



DANGER: Indicates an imminently hazardous situation that, if not avoided, will result in death or serious injury.

This signal word is to be limited to the most extreme situations typically for machine components which, for functional purposes, cannot be guarded.



WARNING: Indicates a potentially hazardous situation that, if not avoided, could result in death or serious injury, and includes hazards that are exposed when guards are removed. It may also be used to alert against unsafe practices.



CAUTION: Indicates a potentially hazardous situation that, if not avoided, may result in minor or moderate injury. It may also be used to alert against unsafe practices.



GENERAL SAFETY GUIDELINES

Safety of the operator is one of the main concerns in designing and developing a new piece of equipment. Designers and manufacturers build in as many safety features as possible. However, every year many accidents occur which could have been avoided by a few seconds of thought and a more careful approach to handling equipment. You, the operator, can avoid many accidents by observing the following precautions in this section. To avoid personal injury, study the following precautions and insist those working with you, or for you, follow them.

Replace any CAUTION, WARNING, DANGER or instruction safety decal that is not readable or is missing. Location of such decals is indicated in this booklet.

Do not attempt to operate this equipment under the influence of drugs or alcohol.

Review the safety instructions with all users annually.

This equipment is dangerous to children and persons unfamiliar with its operation. The operator should be a responsible adult familiar with farm machinery and trained in this equipment's operations. **Do not allow persons to operate or assemble this unit until they have read this manual and have developed a thorough understanding of the safety precautions and of how it works.**

To prevent injury or death, use a tractor equipped with a Roll Over Protective System (ROPS). Do not paint over, remove or deface any safety signs or warning decals on your equipment. Observe all safety signs and practice the instructions on them.

Never exceed the limits of a piece of machinery. If its ability to do a job, or to do so safely, is in question - **DON'T TRY IT.**

I-180TS2

Illustration Assembly

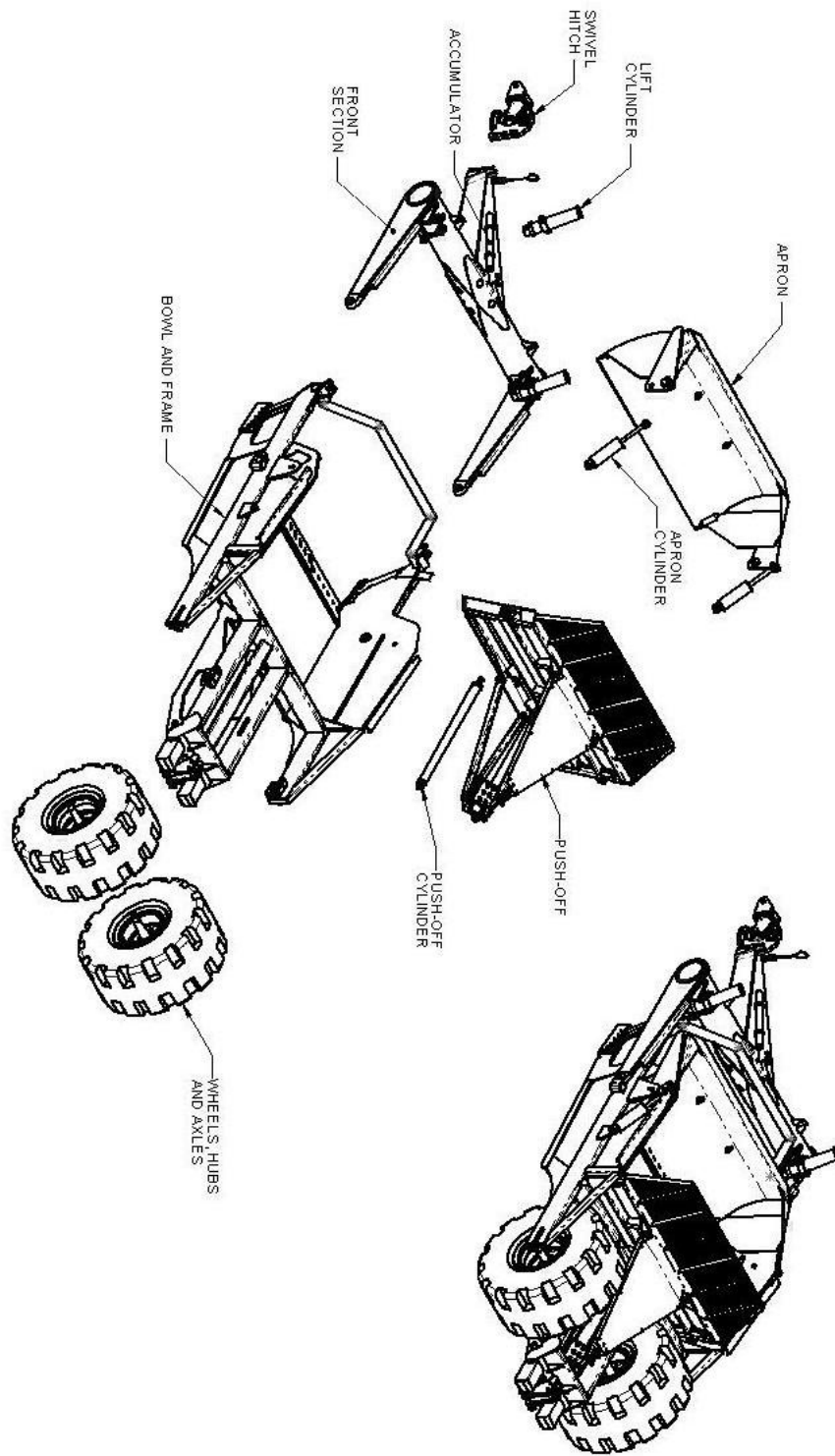

I-180TS2

Swivel Hitch Part No. A125224

Changed hitch to one unit

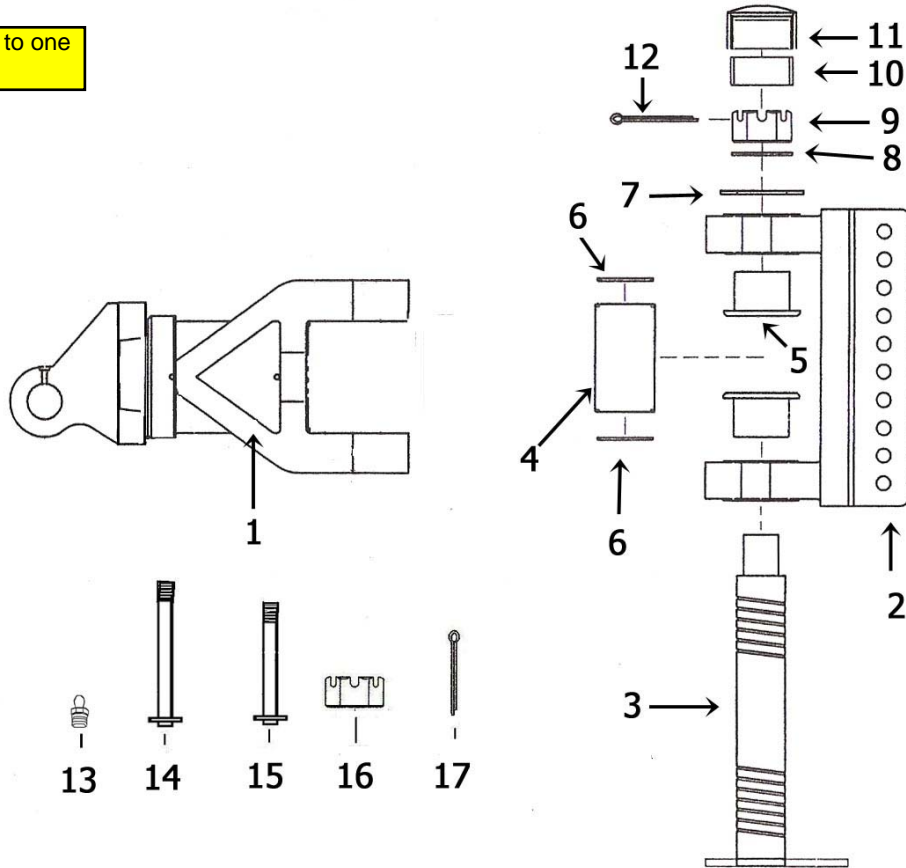

STS350P001

Key Number	Part Number	Description
1	A125224	Hitch: 360 Deg. Cast
2	A125224-03	Bracket: 10 Hole
3	A125224-04	Pin: Main Vertical
4	A125224-05	Spacer: Tube
5	A125224-07	Bushing
6	A125224-09	Seal: O-ring
7	A125224-13	Spacer: 6"
8	A125224-14	Washer: 2 1/2"
9	A125224-15	Nut: Slotted 2-1/2" NC
10	A125224-16	Sleeve: 2" Rubber
11	A125224-17	Cap: For Vertical Pin
12	A125224-18	Pin: Cotter 3/8 x 5"
13	14505	Grease Fitting Straight
14	A123299-08	Pin: Four Ear Drawbar to Hitch 1 1/2" X 12 5/8" L
15	A123299-07	Pin: Two Ear Drawbar to Hitch 1 1/2" X 12 5/8" L
16	AFN-00014	Nut: 1 1/2" Slotted
17	AFP-00001	Pin: Cotter 1/4 X 3

I-180TS2

Front Section Frame

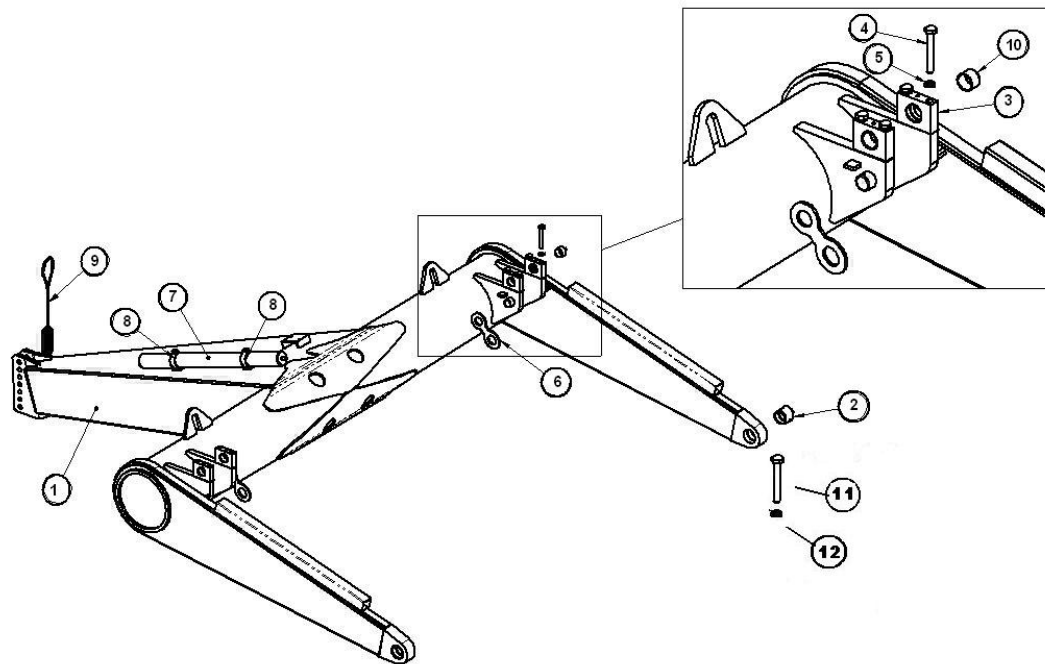

Key Number	Part Number	Description
1	A123320	Front Section
2	A123320-08	2" ID x 3-1/2" OD x 3" long bronze bushing
3	A123456	Trunion mount block
4	AFB-00039	"Bolt, 3/4" NC x 5-1/2" long, gr. 8"
5	AFW-00002	3/4" lock washer
6	A123320-20	Travel Lock
7	A125005	Accumulator
8	A125009	Mounting brackets
9	A125109A	Hose Support
10	A125179	Trunion Bushing
11	AFB-00021	1x5-1/2 NC Gr 8 Bolt
12	AFN-00037	1" NC Locknut

I-180TS2

Lift Cylinder 5-1/2 x 20 Part No. 125044

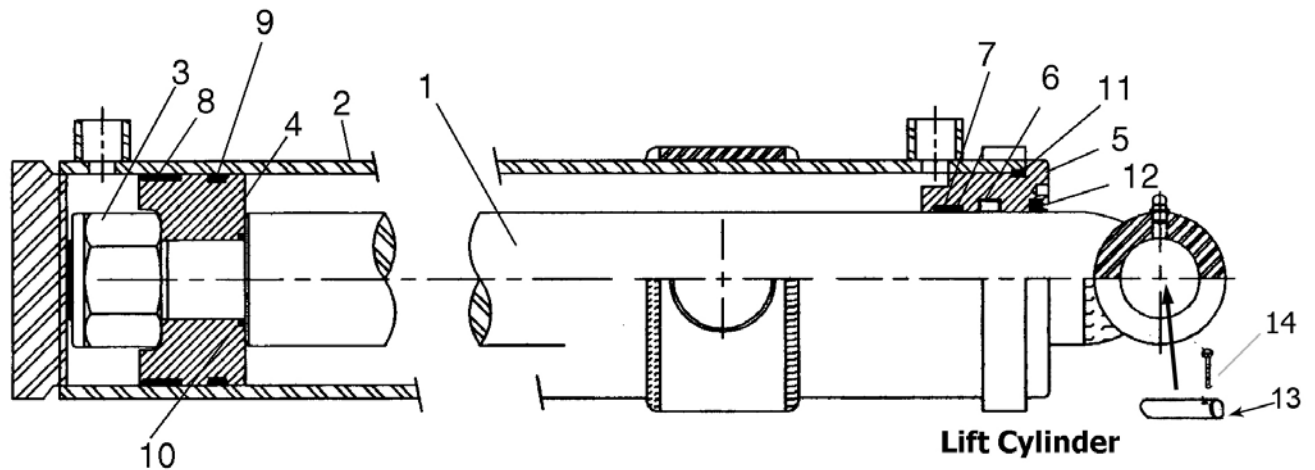

A-123326-III

Key Number	Part Number	Description
1	A123326-1	Piston Rod: 2-1/2"
2	A125044-02	"Barrel Weldment, 5-1/2"
3	A125159-34	1-3/4 NF Locknut
4	A125044-04	"Piston, 5-1/2"
5	A125044-05	"Gland, 5-1/2"
6	A123324-6	Rod Seal
7	A123324-3	Wear Band ID for Gland
8	A125044-10	"Wear Ring, 5-1/2"
9	A125044-15	"Piston Seal, 5-1/2"
10	A123324-10	"O-Ring, ID of Piston"
11	A125044-20	"O-Ring, OD of Gland"
12	A123324-7	Rod Wiper
	A125044-40	Seal Kit (Items 6-12)
13	A123335	Pin, 2" X 10 1/2" Lg.
14	AFP-00001	Cotter Pin, 1/4" X 3"

I-180TS2

Apron Assembly

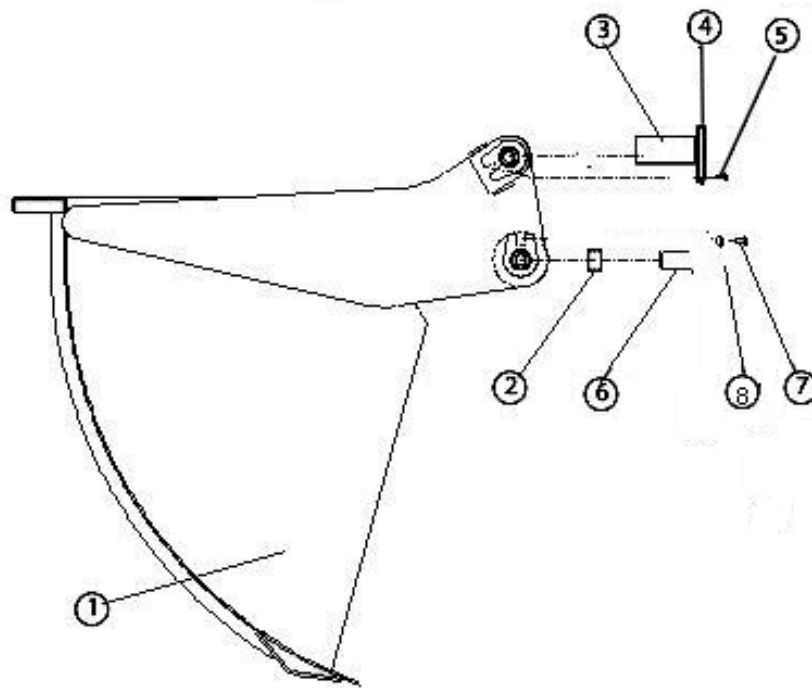

A-123322-iii

Key Number	Part Number	Description
1	A123322	Apron Model I-180-TS
2	A125249	Bushing: 2" ID Ball Swiv. w/ Graph Plugs
3	A123322-14	"Pin: 2" x 3-3/4" long, For Apron cyl rod end"
4	A123358	Flanged Bolt Bushing
5	AFB-00079	Bolt: 5/8 X 1 1/2"
6	A123321-109	Apron Pivot Pin w/grease zerk
7	AFB-00012	1/2" Bolt 1/2 X 4 1/2"
8	750500	1/2" lock nut

I-180TS2

Apron Cylinder A125257

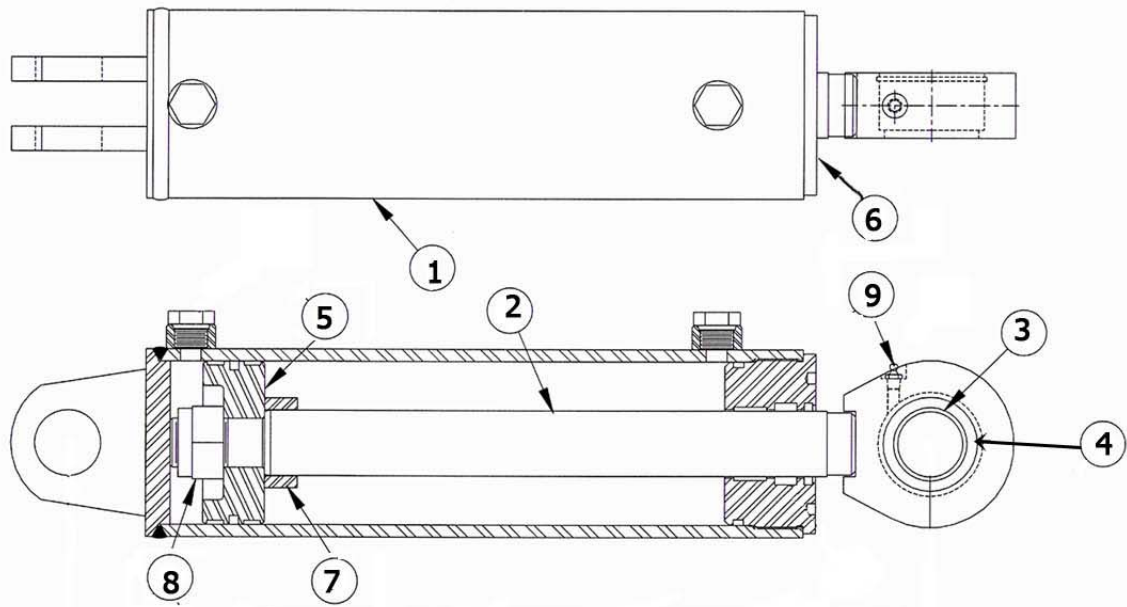

A125257

M180T350P002

Key Number	Part Number	Description
1	A125257-10	Barrel Weldment
2	A125257-20	Rod
3	A125257-35	Uniball Bushing
4	A125057-36	Snap Ring
5	A125257-30	Piston
6	A125257-31	Head
7	A125257-32	Spacer
8	A125257-33	1 1/2" Toplock Nut
9	14505	Grease Zerk
	A125257-40	Seal Kit

I-180TS2

Bowl & Frame Assembly Illustration

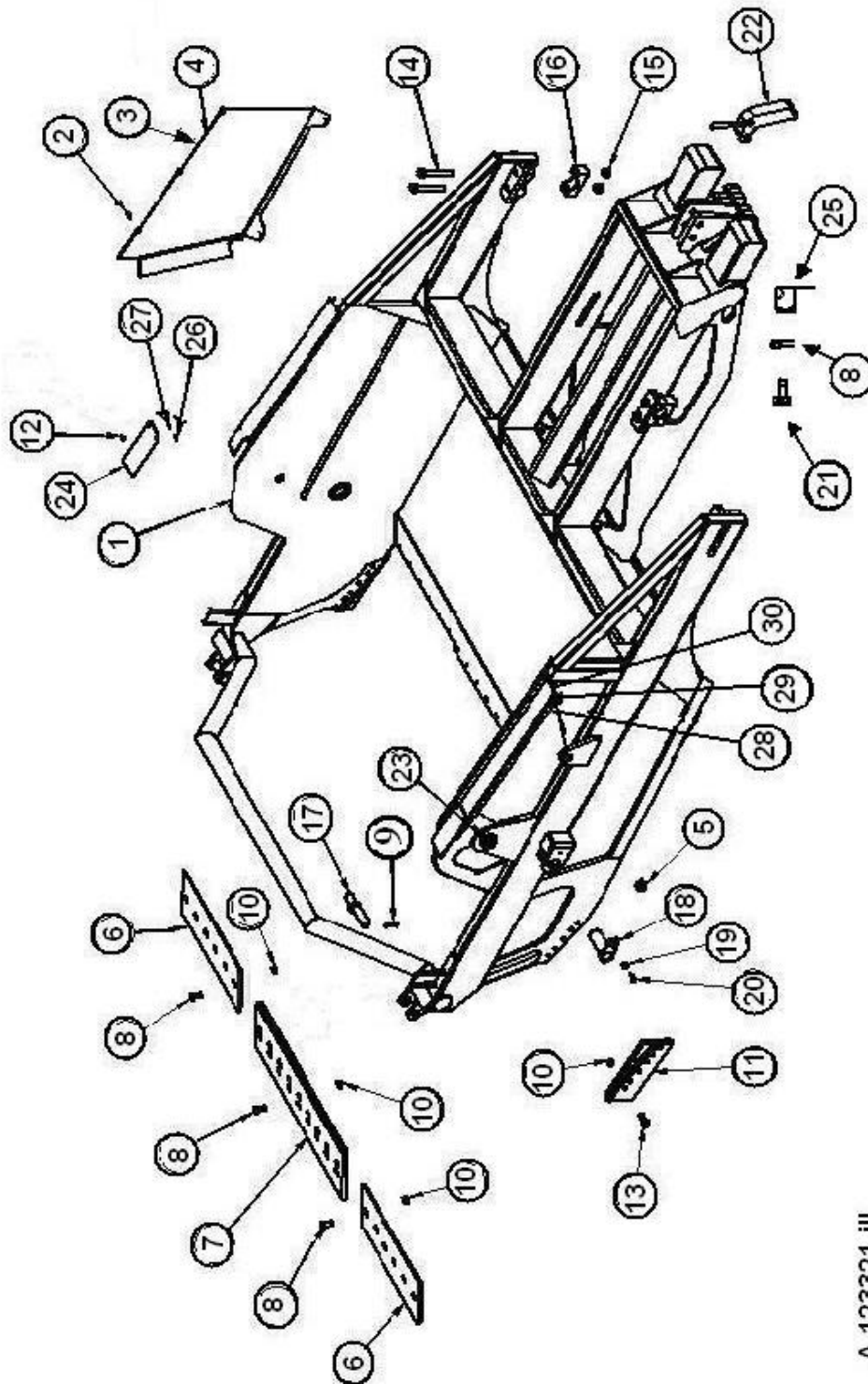

A-123321-III

I-180TS2

Bowl & Frame Assembly Parts I-180TS2

Key Number	Part Number	Description
1	A123321	Bowl and frame assembly
2	AFB-00094	Flanged Bolt: 3/8" NC x 1" long
3	A123369-1L	Left side dirt shield
4	A123369-1R	Right side dirt shield
5	A125018	Bushing: 2-3/8" OD x 2" ID x 1-1/4 Lg
6	A125103	"Left & Right Straight Corner Blade
7	A125072*	"Center blade, 18" Straight, reversible"
	A125072-SER*	"Center blade, 18" dbl serrated, reversible"
8	PB1P-NC-100-0275	Plow bolt: 1" NC x 2-3/4" long
9	AFP-00001	Cotter Pin
10	AFN-00012	Nut: 1" NC
11	A123357	"Bank shaver/router bit, reversible, L & R"
12	AFB-00027	Bolt: 3/8 X 1 1/2
13	AFB-00018	Bolt: 1" NC x 3" long (5 per router blade)
14	AFB-00109	Bolt: 1-1/4" NF x 9" long (9)
15	AFN-00032	Nut: 1-1/4" ??NF
16	A123321-65	Axle mount
17	A123335	Lift cylinder pin
18	A123321-09	Main frame pin
19	A123358	Flanged bolt bushing
20	AFB-00079	Bolt: 5/8" x 1 1/2" long
21	A123321-98	Pins
22	A123321-89	Pin Keeper
23	A123321-107	Weld in Apron Boss
24	A123369-13	Dirt Shield Flap
25	A125006	Safety Snap Pin 1/4 x 2-1/4 with sq retainer
26	7450	3/8 NC Nut
27	AFW-00010	3/8 Flat Washer
28	A125020	32" Grease Line
29	A125026	3/8 NF Bulkhead Nut
30	A125019	Grease Fitting 1/4 - 28 X 54" L

I-180TS2

Pushoff Assembly

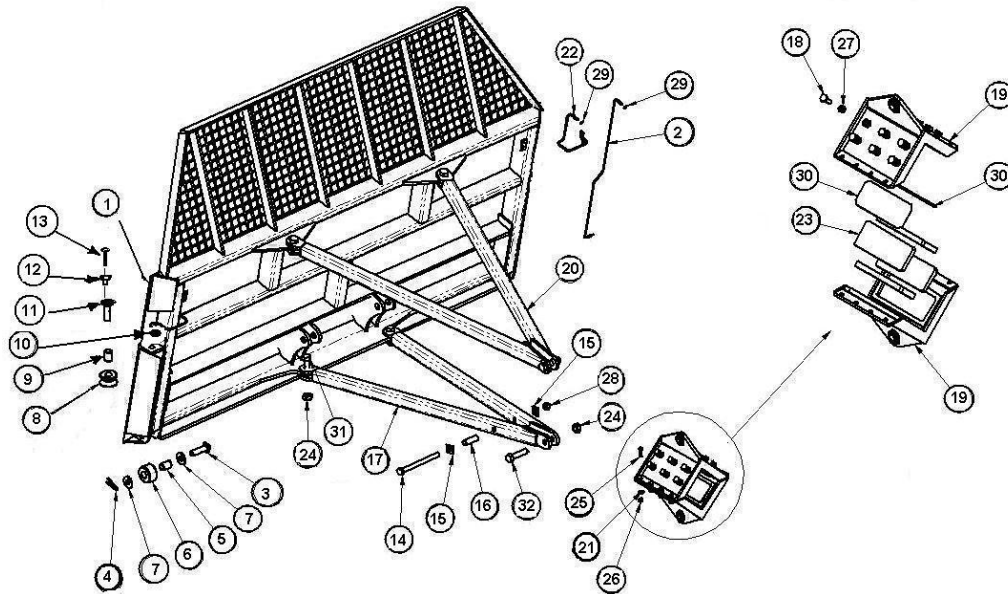

Key Number	Part Number	Description
1	A123323	Pushoff Assembly
2	A125023	Grease line, Outside floor roller 48"
3	A123323-21	Pin: 1-1/4" x 4-1/8" long
4	AFP-00001	Cotter Pin: 1/4" x 3"
5	A10163	Bushing: 1-3/4" O.D. x 1-1/4" I.D.
6	A10164	Roller
7	AFW-00015	Washer
8	A123323-24	Roller
9	A123323-24B	Bushing: 2 ID X 2.5 OD
10	A123323-09	Spacer
11	A123323-23	Pin: Upper Roller 2 x 7 7/8
12	A123358	Pin Keeper
13	AFB-00079	Bolt: 5/8" x 1 1/2"
14	AFB-00103	1 x 12 Bolt
15	AFW-00019	Wedge Washer
16	A123323-48	Wedge Spacer
17	A123323-35	Bottom Support
18	AFB-00060	Bolt: 3/4" NF x 2" long
19	A123364	Slide Guide Box
20	A123323-36	Top Support
21	8110	5/8 Lock Washer
22	A125022	"Grease line, v-roller 18"
23	A123364-08	Plastic slide
24	AFN-00009	1 1/4 NF Locknut
25	6684	5/8 x 2 NC gr. 8 Bolts
26	7530	5/8 NC gr. 8 Nuts
27	AFN-00023	JamNut: 3/4" NF
28	AFN-00001	NF Nut Lock 1" NF
29	A125026	Bulk Head Nut
30	A123364-3	Shim Plate
31	AFB-00076	Bolt: 1 1/4 NF X 4
32	AFB-00075	Bolt: 1 1/4 NF X 5

I-180TS2

Pushoff Cylinder 4" Bore x 60" Stroke Part No. A125178

Changed from
A123360 7/09 sn
22209

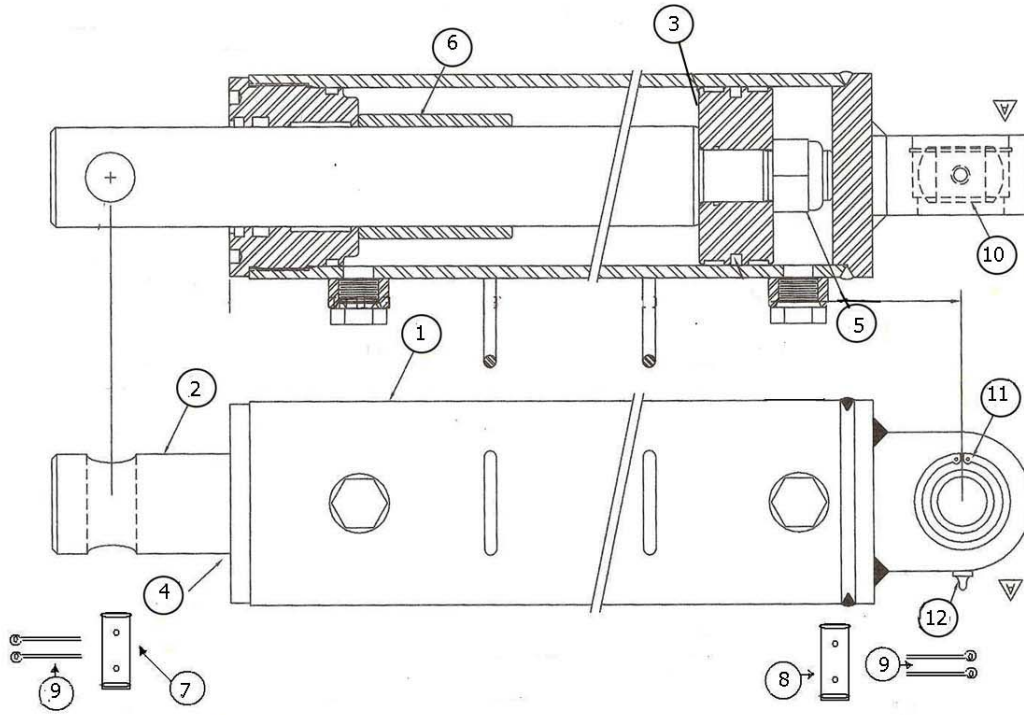

A125178

M180T350P001

Key Number	Part Number	Description
1	A123360-01	Barrel
2	A123360-02	Rod
3	A123360-03	Piston
4	A123360-04	Head Gland
5	A123360-05	Lock Nut
6	A123360-07	Spacer Sleeve
7	A123323-38	Rod End Pin 5-1/16 x 1-1/2
8	A123323-41	Barrel End Pin 4-9/16 x 1-1/2
9	AFP-00001	1/4 x 3 Cotter Pin
10	A125178-35	Bushing
11	A125178-36	Snap ring
12	14505	Grease Fitting 1/8 NPT st
	A123360-16	Seal Kit

I-180TS2

Wheel Assembly

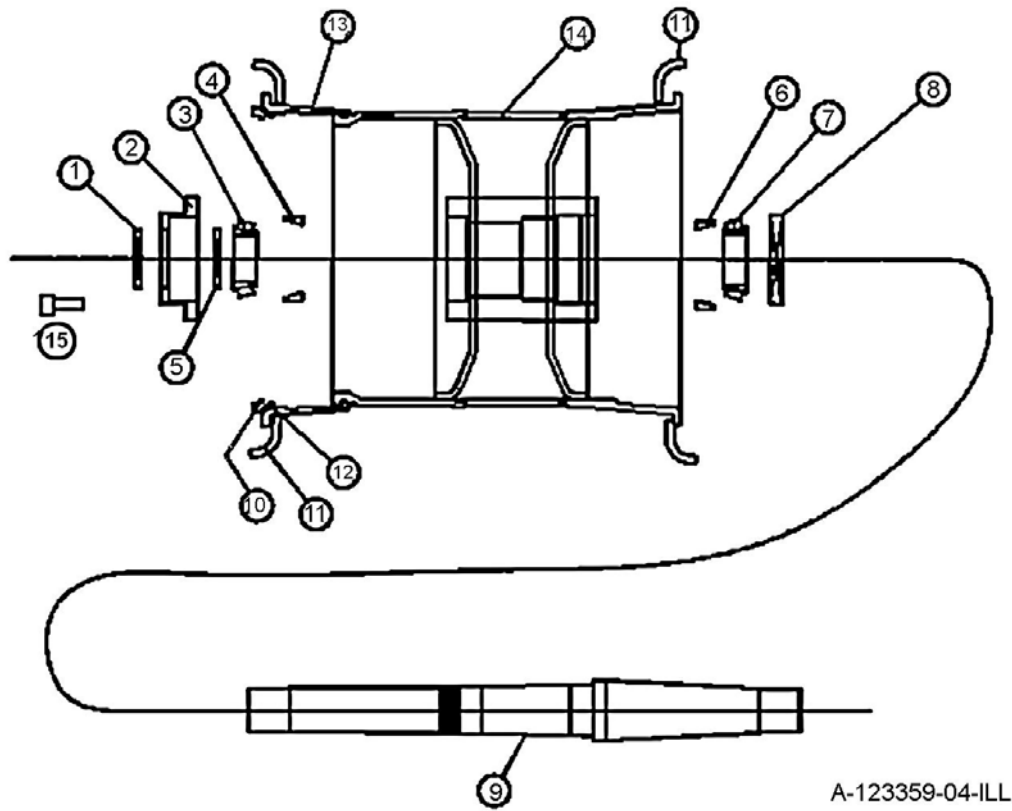

A-123359-04-ILL

Key Number	Part Number	Description
1	A125008	Outer Seal CRWH!
2	A123359-03	Cap-Seal Mount
3	A125016	Outer Bearing Cone 77375
4	A125017	Outer Bearing Cup 77675
5	A125013	Spindle Nut
6	A125015	Inner Bearing Cup
7	A125014	Inner Bearing Cone
8	A125007	Inner Seal CRSHA1
9	A123368	Axle
10	A12042	Lock Ring
11	A12041	Side Ring
12	A12047	O-Ring
13	A12043	Collar
14	A123359-04	25 X 25 Wheel/Hub
15	AFB-00082	5/16 X 1 1/2 Bolt for Hubcap

I-180TS2

Hydraulic Manifold Assembly

IMPORTANT: This Hyd. Manifold was integrated into production April, 2006 It replaces A125070 valve.

For older machines see master parts book on Ashlandind.com.

HYDRAULIC MANIFOLD ASSEMBLY A125174

SETTING THE APRON AND PUSHOFF VALVE

The manifold block containing the pushoff sequence valve cartridge and apron sequence valve cartridge is used to control two hydraulic circuits with one hydraulic remote. When the tractor hydraulic remote is activated, oil flows first to the apron cylinders until they are fully extended. Once the cylinders are fully extended, the apron circuit's hydraulic pressure begins to increase. Once the pressure threshold is surpassed (which is adjustable, see adjustment section), the sequence valve diverts the oil flow to the pushoff's hydraulic circuit. Once the push off is completely extended, the operator then reverses the tractor's hydraulic remote. The counterbalance valve will hold the apron open until the push off is fully retracted. The Apron sequence valve then opens and allows the apron to close.

Setting the valves:

STEP 1 PUSHOFF SEQUENCE VALVE

Loosen the lock nut (9/16") on the sequence valve cartridge. Turn the setscrew (4mm) clockwise until the front apron rises before the push-off begins to advance. (Earthmover should be empty) Turn the adjustment screw an additional 1/4 turn clockwise and tighten jam nut.

STEP 2 Counter Balance VALVE

Loosen the lock nut (9/16") on the counterbalance valve cartridge. Turn the setscrew (4mm) counter-clockwise until the apron holds in a raised position while rear gate is being retracted. Turn adjustment screw an additional 1/4 turn, tighten jam nut. DO NOT tighten adjusting screw more than necessary.

Changed numbers
around to avoid
confusion

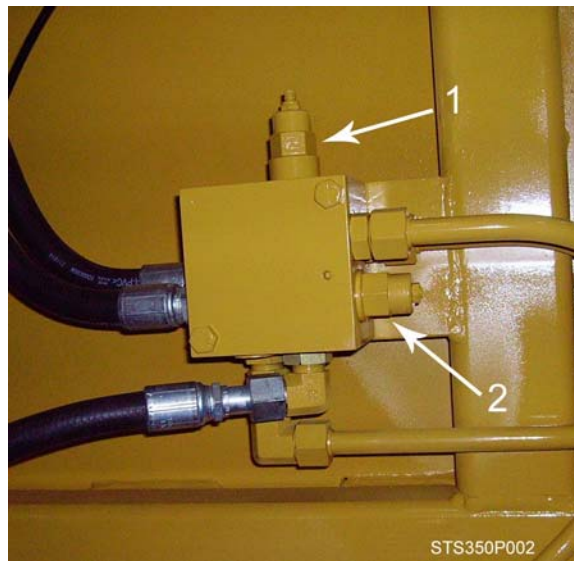

Key Number	Part Number	Description
1	A125162-02	PUSHOFF SEQUENCE CARTRIDGE
2	A125162-01	COUNTER BALANCE CARTRIDGE

I-180TS2

Hydraulic Schematic Tractor

I-180 TS Hydraulic Schematic tractor

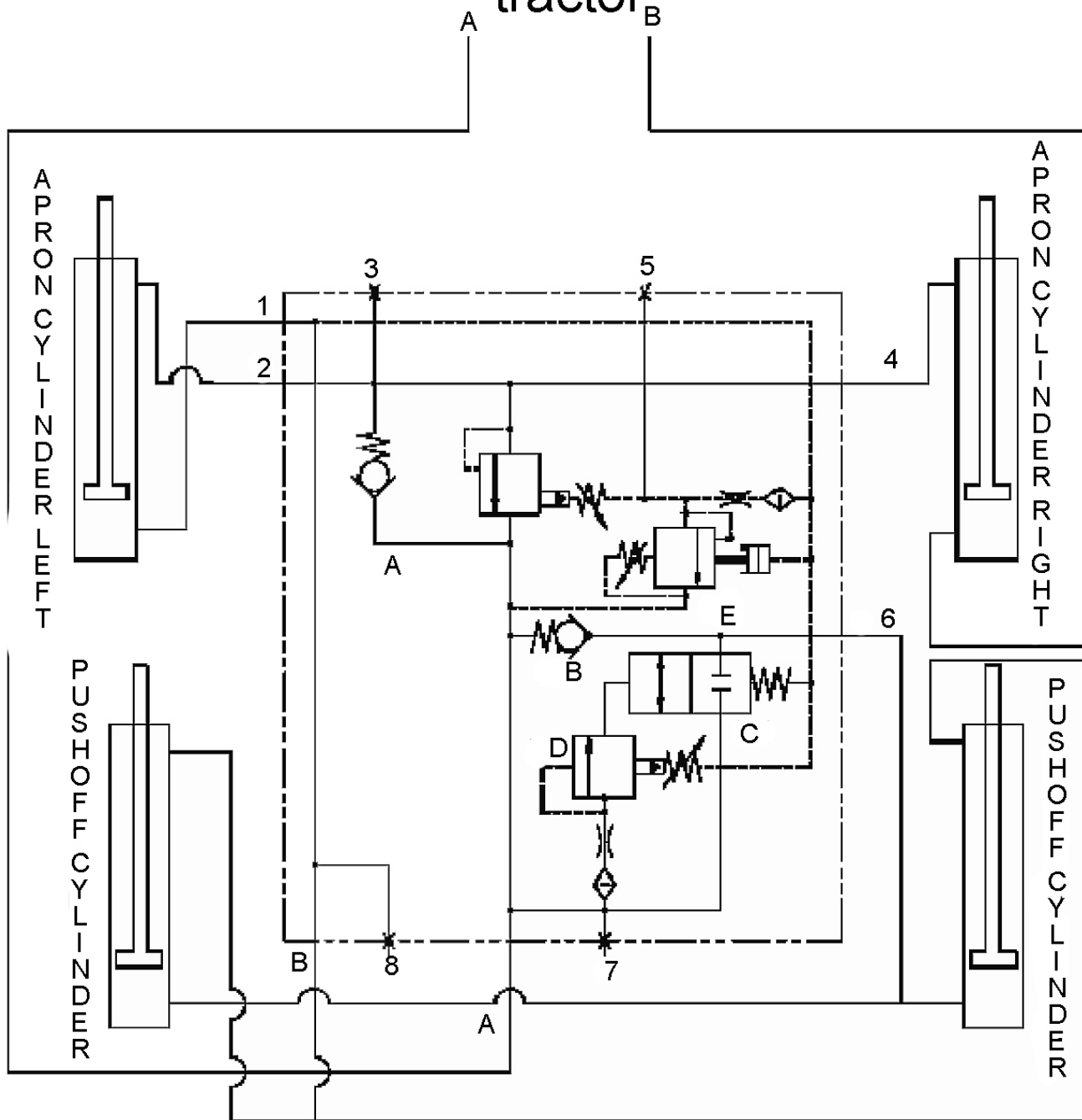

180 hyd schematic-ILL

Key Number	Description
A	Counter Balance Valve
B	Check Valve
C	Directional Control Valve
D	Sequence Valve

I-180TS2

Decals

Added

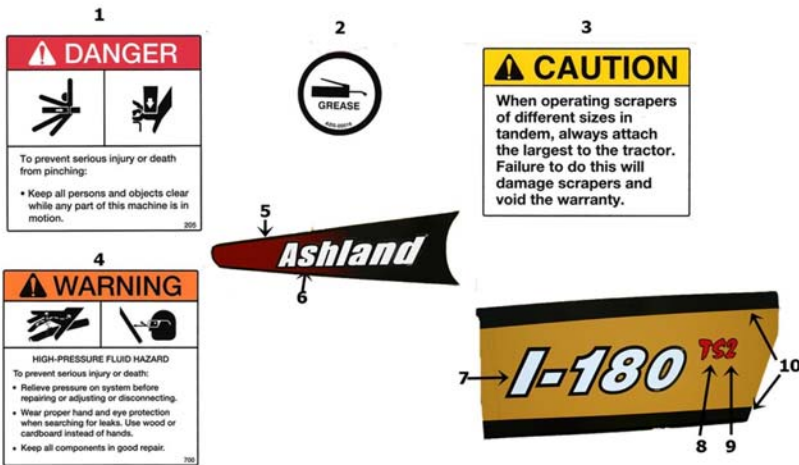
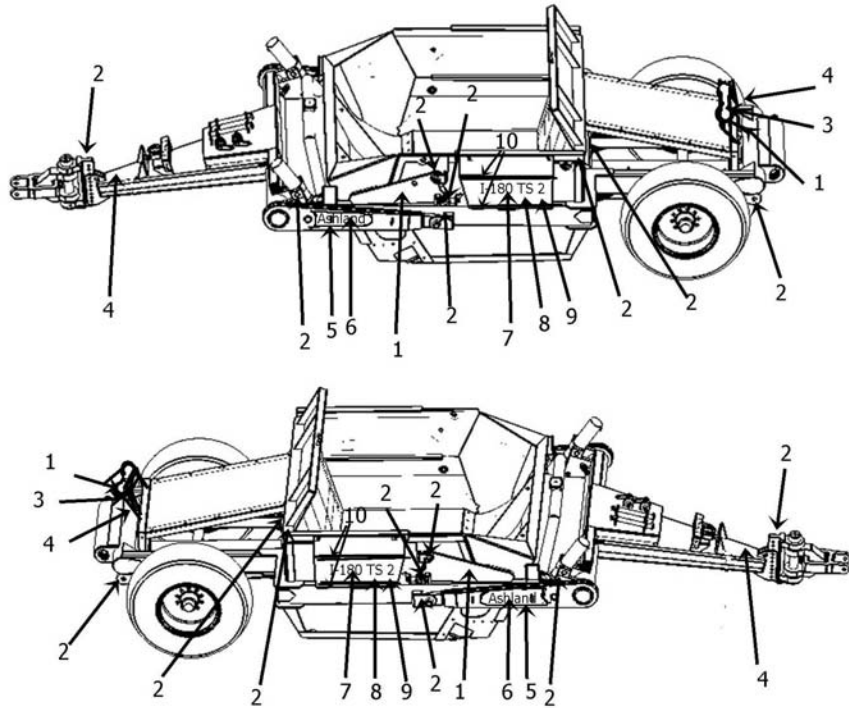

M180T100SD003

Key Number	Part Number	Description
1	ADS-00011	Decal: Pinch Point
2	ADS-00019	Decal: Grease
3	ADS-00015	Decal: 'Caution' Tandem Use
4	750464	Decal: "High Pressure Fluid Hazard"
5	ADS-00003	Decal: Black Wedge
6	ADS-00001	Decal: Large Ashland
7	ADS-00012	Decal: I-180
8	ADS-00005	Decal: TS
9	ADS-00022	Decal: S
10	ADS-BLCKSTRIPE	Decal: 3" Black Stripe Kit

I-180TS2

Grease Locations

Added



M180T100SD003

I-180TS2

Maintenance check list

MAINTENANCE CHECKLIST

1. Grease all zerks.
 - a) Every 8 hours of operation.
 - b) See Lubrication Points section on next page.

2. Greasing the hubs.
 - a) Re-pack wheel bearings after 600 hrs of operation.
 - b) Completely clean grease out of hub and bearings every 1200 hours of operation.

3. Check tire pressure.
 - a) 20.5 - 25, 12-ply tire requires a tire pressure of 35-40 psi on a rear machine, 40-50 on a front machine.

4. Check all pins for signs of wear.
 - a) Daily

5. Check wheel lug nut torque.
 - a) After first 2 hours of operation.
 - b) Recheck daily for next 2 weeks.
 - c) Tighten wheel lug nuts in a star pattern.
 - d) Torque wheel lug nuts to 450 ft-lbs.

6. Check and retighten all bolts.
 - a) After initial 10 hours of use.
 - b) Again after 50 hours of use.
 - c) See Torque Specifications on next page.

7. Inspect cutting edges.
 - a) Daily
 - b) Replace cutting edges when center blade has been worn to approximately 6" and side edges worn to approximately 4".



CAUTION! Failure to replace worn cutting edges may result in unnecessary wear to the earthmover sides and floor.

Note: Please specify left or right "L" shaped cutting edges when ordering replacements.

I-180TS2

Torque Specifications

TORQUE SPECIFICATIONS

<i>Bolt</i>	<i>Torque</i>
<i>Diameter</i>	<i>Ft-lbs</i>
<i>1/4</i>	<i>12</i>
<i>5/16"</i>	<i>25</i>
<i>3/8"</i>	<i>45</i>
<i>7/16"</i>	<i>70</i>
<i>1/2"</i>	<i>110</i>
<i>9/16"</i>	<i>150</i>
<i>5/8"</i>	<i>220</i>
<i>3/4"</i>	<i>380</i>
<i>7/8"</i>	<i>600</i>
<i>1"</i>	<i>900</i>
<i>1-1/8"</i>	<i>1280</i>
<i>Lug Nuts</i>	<i>750</i>

LUBRICATION

1. Grease all zerks every 8 hrs of operation with high quality, general-purpose grease.
 - a) Grease until grease flows from around pin.

Lubrication Points (see III.)

1. Hitch – Horizontal and vertical pins.
2. Lift Cylinders – Rod end & Trunion; Both left & right sides.
3. Front Arm Pivot Joint – Both left & right sides.
4. Apron Cylinders – Rod clevis pin; Both left & right sides.
5. Apron Pivot Pin – Both left & right sides.
6. Hold-down Rollers – Both left & right sides.
7. Floor Rollers – Both left & right sides.
8. Tapered Rollers – Both left & right sides.

I-180TS2

Troubleshooting

TROUBLESHOOTING

Introduction

With proper care and maintenance, the I-180TS will give many years of reliable service. When a situation arises where the earthmover performance is not satisfactory, this section will give some pointers on finding and correcting the problem.

Grease zerk will not take grease.

1. Grease zerk plugged.
 - a) Remove and replace grease zerk.
 2. Pin is frozen.
 - a) Remove, clean, and inspect pin.
 - b) Replace pin if necessary.
 3. Bushing grease passage is not aligned with grease zerk.
 - a) Remove, clean, inspect, and realign bushing.
 - b) Replace bushing if necessary and realign.
-

Push-off rollers do not roll.

1. The rollers need lubrication.
 - a) Check zerk hole and grease.
 - b) Remove pin, clean, inspect, and replace if necessary.
 2. The roller bushing is worn out.
 - a) Remove roller assembly and replace bushing.
 - b) See parts manual.
-

Cylinders will not hold in preset position, i.e. the cylinder creeps.

1. Seals leaking internally.
 - a) Remove and replace seal kit.
-

Machine cuts unevenly.

1. Cutting edges worn unevenly.
 - a) Replace cutting edges.
2. Improperly inflated tires.
 - a) Check air pressure in tires.

I-180TS2

Warranty Statement

Limited Warranty Statement

Ashland Industries Inc. warrants each new product to be free from defects in material and workmanship. This warranty is applicable only for the normal service life expectancy of the product or components, not to exceed **six consecutive months** from the date of delivery of the new Ashland Industries product to the purchaser, or the date the product is first put into service via a rental agreement or other means, whichever occurs first.

The major components of swivel hitches used on Industrial series scrapers are warranted for three consecutive months from the date of delivery of the new Ashland Industries product to the purchaser, or the date the product is first put into service via a rental agreement or other means, whichever occurs first, except those components described below.

Genuine Ashland Industries Inc. replacement parts and components will be warranted for 30 days from date of purchase, or the remainder of the original equipment warranty period, whichever is longer.

Under no circumstances will it cover any merchandise or components thereof, which in the opinion of the company, has been subjected to misuse, unauthorized modification, alterations, an accident or if repairs have been made with parts other than those obtained through Ashland Industries Inc.

Ashland Industries Inc. in no way warrants Tires since their respective manufacturer warrants these items separately. Please call Ashland Industries Inc. to receive phone numbers of tire suppliers.

Ashland Industries Inc. in no way warrants wearable items such as cutting edges, front dolly wheel balls, socket halves, rollers, bushings, yoke hitch pins, hitch bushings, etc.

Our obligation under this warranty shall be limited to repairing or replacing, free of charge to the original purchaser, any part that, in our judgement, shall show evidence of such defect, provided further that such part shall be returned within 30 days from the date of failure to Ashland Industries Inc. routed through the dealer and distributor from whom the purchase was made, transportation charges prepaid. Upon warranty approval proper credits will be reimbursed for transportation.

This warranty shall not be interpreted to render Ashland Industries Inc. liable for injury or damages of any kind or nature to person or property. This warranty does not extend to the loss revenue, extra labor cost associated with downtime, substitute machinery, rental or for any other reason.

Except as set forth above, Ashland Industries Inc. shall have no obligation or liability of any kind on account of any of its equipment and shall not be liable for special or consequential damages. Ashland Industries Inc. make no other warranty, expressed or implied, and, specifically, Ashland Industries Inc. disclaims any implied warrant or merchantability or fitness for a particular purpose. Some states or provinces do not permit limitations or exclusions of implied warranties or incidental or consequential damages, so the limitations or exclusion in this warranty may not apply.

This warranty is subject to any existing conditions of supply which may direct affect our ability to obtain materials or manufacture replacement parts.

Ashland Industries Inc. reserves the right to make improvements in design or changes in specifications at any time, without incurring any obligation to owners of units previously sold

No one is authorized to alter, Modify or enlarge this warranty nor the exclusion, limitations and reservations.

A

Ashland Industries Inc.
Warranty Department