

Ashland EARTHMOVERS



I-175XL2 PARTS MANUAL

0611



Ashland Industries Inc.
1115 Rail Drive
P.O. Box 717
Ashland, WI. 54806
Ph: 877-634-4622 Toll Free
Ph: 715-682-4622
Fx: 715-682-9717
www.ashlandind.com

MEMBER



CONSTRUCTION INDUSTRY
MANUFACTURERS ASSOCIATION



ASHLAND SCRAPERS

Serial Number

WELCOME TO OUR NEW CUSTOMERS!

Thank you for your purchase of an Ashland scraper and the confidence you have placed in us to handle your earthmoving projects. Years of research, testing and successful application have been spent to ensure quality and maximum performance for our customers. Please read and understand this manual before attempting to attach or operate this scraper. This manual should always remain with the machine. Be sure and fill out and send in the owners registration form at the beginning of this manual, or you may fill out the form on-line by going to ashlandind.com and click on "Register your Machine" at the bottom of the page.

SCRAPER ID NUMBER

The serial number plate for the scraper is located on the right rear area of the scraper. The letter and numbers stamped identify the serial number, model number and capacity of the scraper. Please record this serial number for use in ordering parts, warranty issues and to trace your equipment if it is ever stolen.

References to serial number breaks on parts are located in the manual with a reference sequence of XXXXX-XXXXX. The beginning number records the serial number start of the use of that part. The ending number is the final serial number use of the part within this machine.



ASHLAND SCRAPERS

How to Order Parts

HOW TO ORDER PARTS:

IMPORTANT

Parts must be ordered through your local authorized ASHLAND dealer.

Be sure to state MODEL and SERIAL NUMBER of your machine, PART NUMBER, DESCRIPTION and QUANTITY needed.

Unless this is done, we cannot provide prompt service or assure shipment of the correct parts.



Ashland Industries weldable replacement parts are available to rebuild, modify or update your scraper to current factory specifications.

ASHLAND SCRAPERS

Operators and Maintenance

This scraper is a durable piece of equipment and with proper care will yield many years of trouble free operation. The scraper requires a power source with TWO 4 way (double acting) hydraulic control valves.

The scraper should be greased at all points where grease fittings are provided. Check the oil levels in the tractor hydraulic system and add to maintain the proper level. Care should be used when adding oil or when disconnecting any oil line to keep all dirt out of the oil as dirt is a major factor in the failure of hydraulic components.

When the scraper is placed into operation, the operator will have to "feel out" the amount of depth of cut to obtain maximum loading efficiency. This is usually accomplished by taking a lesser and more uniform cut; however, some soil conditions such as loose sand may require a "pumping action" obtained by taking successive deep cuts and lifting out of cut as the tractor begins to lose power or traction.

1. After 10 hours work, all bolts should be checked and tightened if necessary.
2. Every 10 hours all grease fittings should be lubricated.
3. After 50 hours work, all bolts should be rechecked and tightened if necessary. Check wheel bearings and adjust if necessary.
4. After 300 hours work, clean and repack wheel bearings and replace, if necessary, cutting edges, worn pins, etc.

ASHLAND SCRAPERS

XL Assembly

SXL300A001

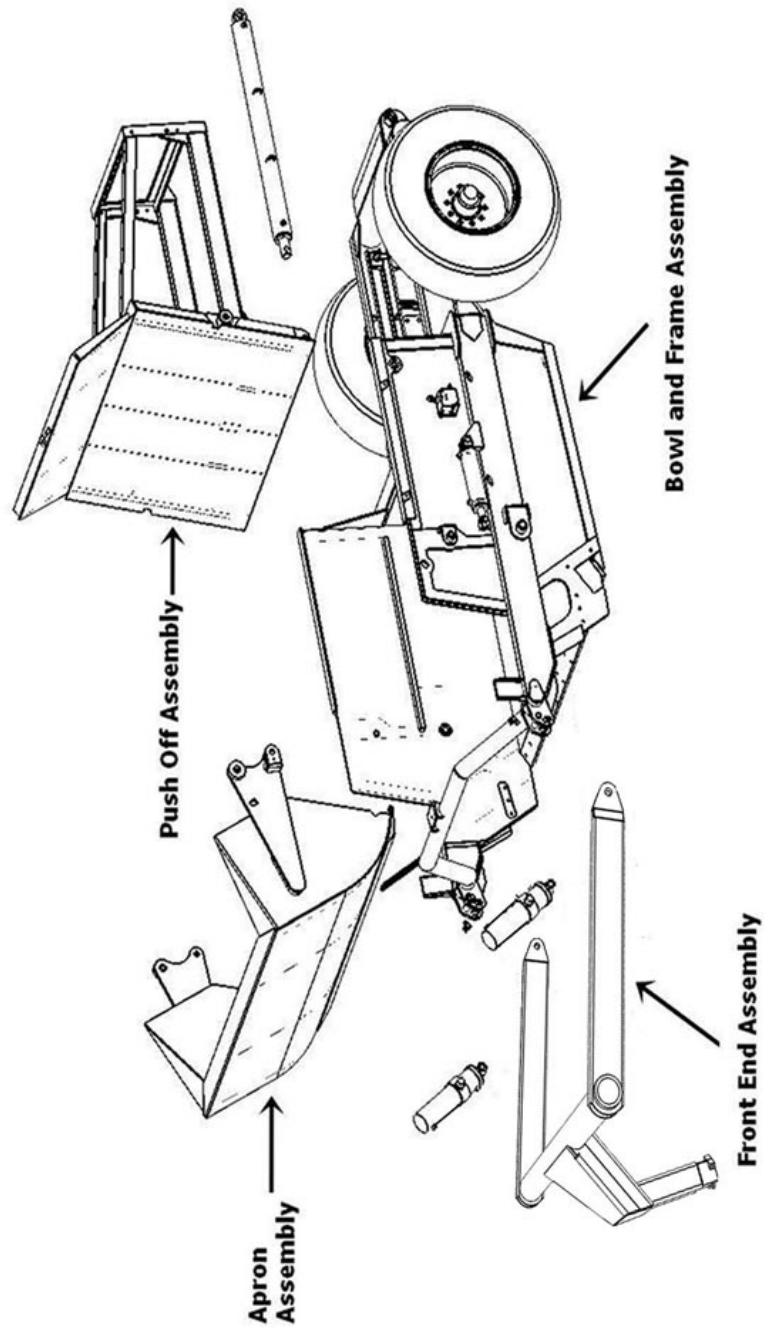

ASHLAND SCRAPERS

Safety Guidelines



GENERAL SAFETY GUIDELINES

Safety of the operator is one of the main concerns in designing and developing a new piece of equipment. Designers and manufacturers build in as many safety features as possible. However, every year many accidents occur which could have been avoided by a few seconds of thought and a more careful approach to handling equipment. You, the operator, can avoid many accidents by observing the following precautions in this section. To avoid personal injury, study the following precautions and insist those working with you, or for you, follow them.

Replace any CAUTION, WARNING, DANGER or instruction safety decal that is not readable or is missing. Location of such decals is indicated in this booklet.

Do not attempt to operate this equipment under the influence of drugs or alcohol.

Review the safety instructions in the operator's manual with all users annually.

This equipment is dangerous to children and persons unfamiliar with its operation. The operator should be a responsible adult familiar with farm or construction machinery and trained in this equipment's operations. **Do not allow persons to operate or assemble this unit until they have read this manual and the owner's manual and have developed a thorough understanding of the safety precautions and how the machine works.**

To prevent injury or death, use a tractor equipped with a Roll Over Protective System (ROPS). Do not paint over, remove or deface any safety signs or warning decals on your equipment. Observe all safety signs and practice the instructions on them.

Never exceed the limits of a piece of machinery. If its ability to do a job, or to do so safely, is in question - **DON'T TRY IT.**

ASHLAND SCRAPERS

Gooseneck Frame Assembly (175)

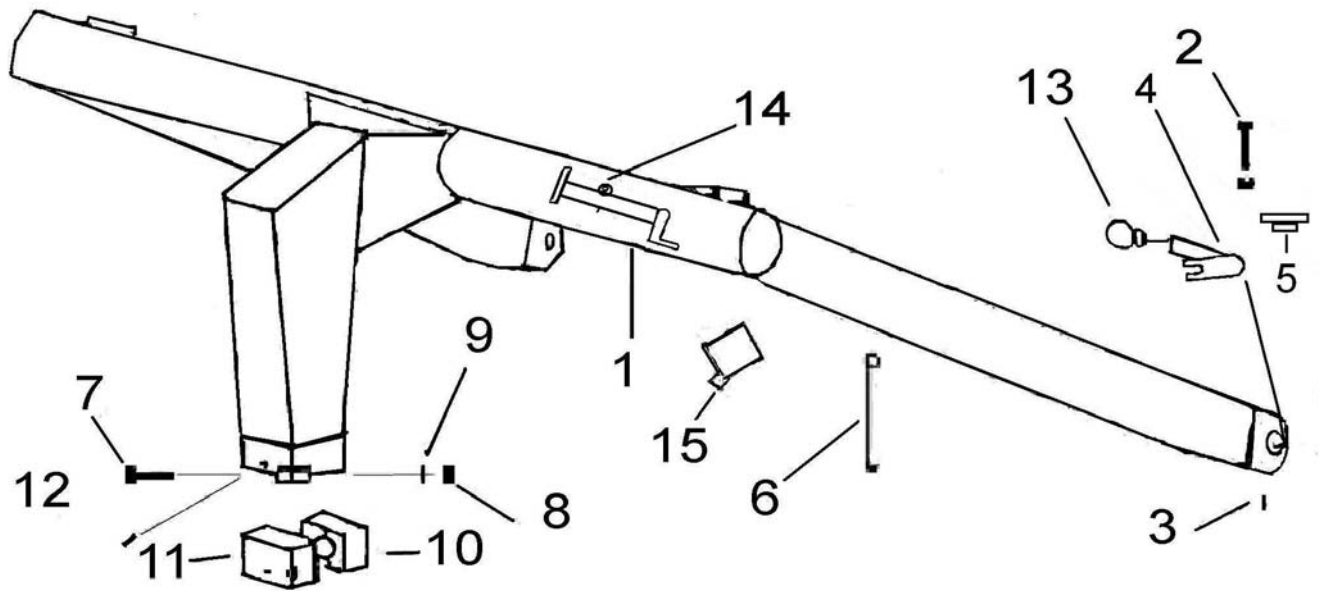

M175X300A002

KEY	PART	DESCRIPTION
1	A17507	Gooseneck Frame
1	AFB-00080	Bolt 5/16" NC x 1/2" Lg.
2	AFB-00079	Bolt, 5/8 NC X 1 1/2" Gr. 8
3	14505	Grease Zerk - Straight
4	A123321-09	Main Frame Pin
5	A123358	Bushing Pin Keeper
6	A123230-20	Travel Lock
7	AFB-00081	"Bolt, 7/8"NF x 5" Lg. Grade 5"
8	7597	"Nut, 7/8"NF"
9	8125	Lockwasher 7/8"
10	A14002	Cast Socket Half - Rear
11	A14003	Cast Socket Half - Front w/Zerk Hole
12	A2206	Grease Zerk - Long Shank
13	A123320-08	"Bushing, 3 ID X 3.5 OD X 3"
14	OPT-00001	Hitch Jack
14	OPT-00001	Hitch Jack
15	A123321-89	Bushing Pin Keeper
15	A125006	Safety Link Pin

ASHLAND SCRAPERS

Apron Assembly (175)

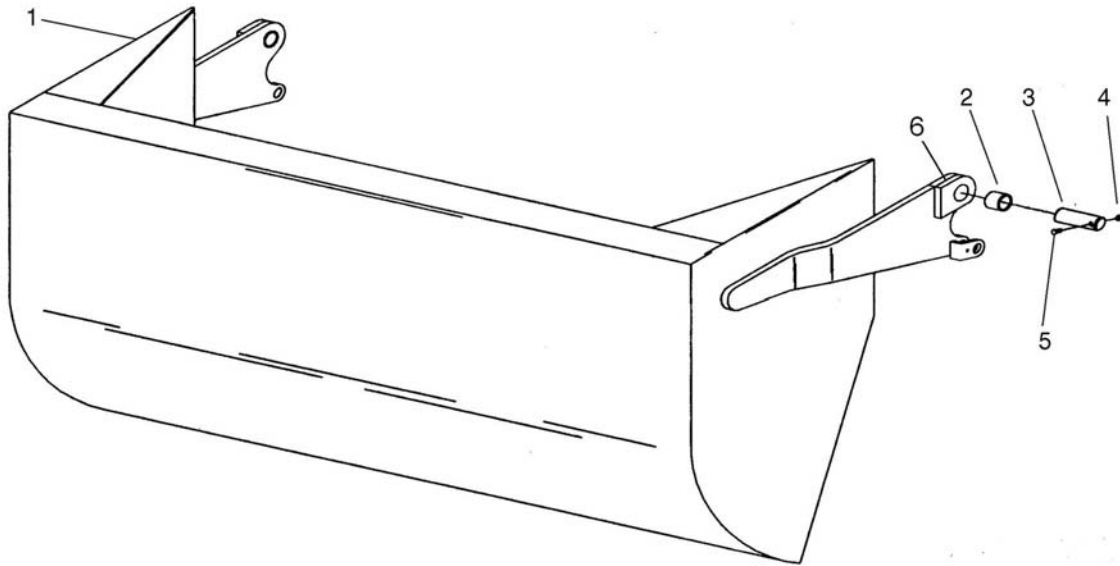

M175300A001

KEY	PART	DESCRIPTION
1	A17505	Apron Model 175
2	A16027	Bushing: 1 1/2 ID X 2 OD X 2" L
3	A123337	Pin: Apron Pivot 110TS-175XL2
4	7450	Nut: 3/8" NC
5	AFB-00049	Bolt: 3/8" NC X 3"
6	14505	Grease Zerk-straight

Bowl & Frame Assembly (155-175-1200)

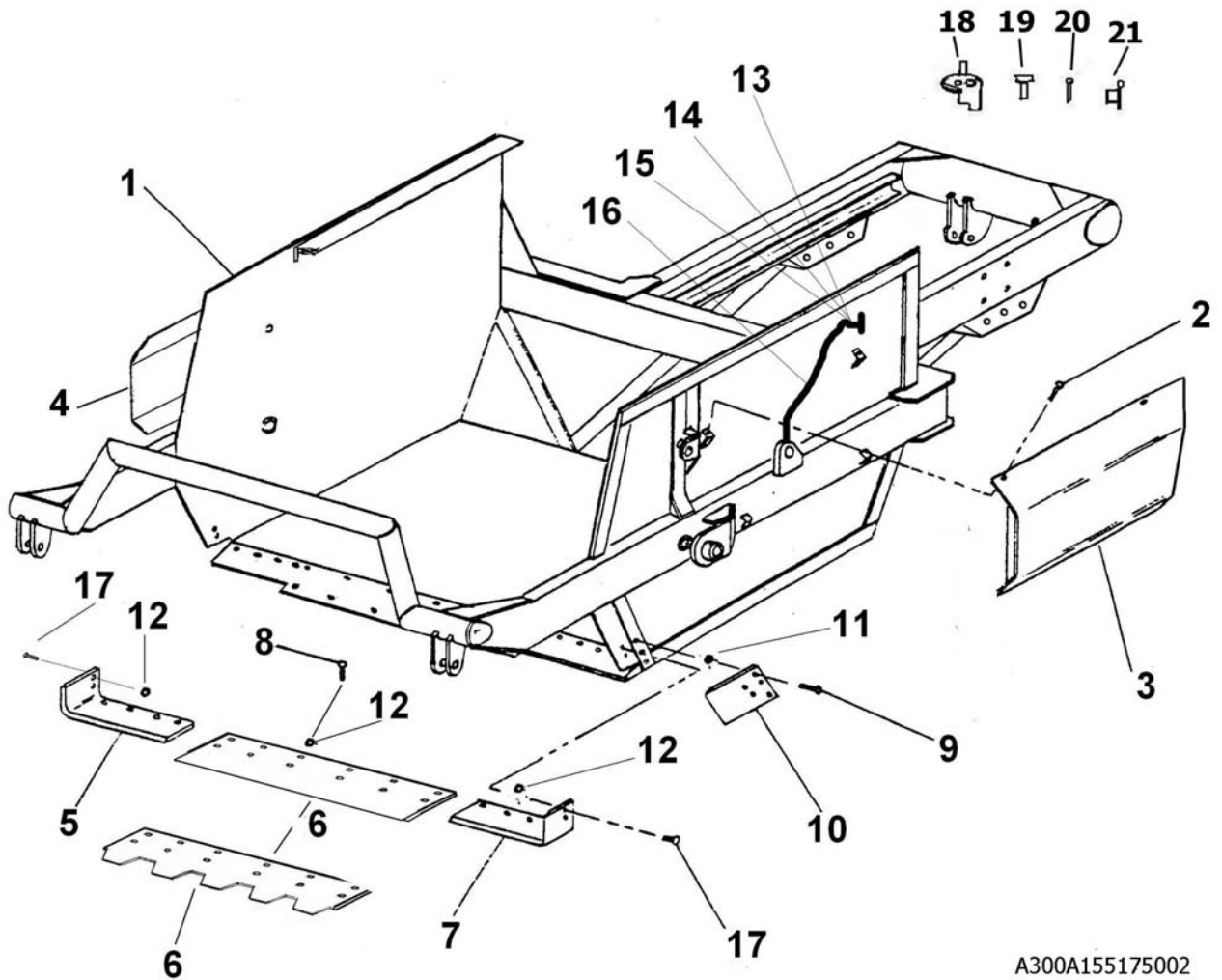

A300A155175002

Blade Bolts Required:	Bolts	Nuts	Qty
A123330 (& Ser)	PB9P-NC-088-0275	AFN-00019	12
A123332 L & R	PB9P-NC-088-0275	AFN-00019	4
	PB9P-NC-088-0275	AFN-00019	2
A123357	AFB-00018	AFN-00012	4

KEY	PART	DESCRIPTION
1	A17503	Bowl and Frame Model 175
2	AFB-00094	Flanged Bolt: 3/8 NC X 1"
3	A123309-62L	Apron Cylinder Guard - Left Side
4	A123309-62R	Apron Cylinder Guard - Right Side
5	A123332L	Left Cutting Edge-8" X22 1/2" X 7/8" Hardened
6	A123330	Center Cutting Edge, 1 1/8 X 12" X 63"
	A123330-SER	Center Currint Edge, (Optional) Serrated, 1 1/8 X 12" X 63"
7	A123332R	Right Cutting Edge-8" X 22 1/2" X 7/8" Hardened
8	PB9P-NC-088-0275	"Plow bolt, 7/8" NC x 2-3/4"
9	PB9P-NC-088-0225	"Plow bolt, 7/8" NC x 2-1/4"



PHONE : 715-682-4622 Fax: 715-682-9717

ASHLAND SCRAPERS

Bowl & Frame Assembly (155-175-1200)

KEY	PART	DESCRIPTION
10	AFB-00018	Bolt: 1" NC X 3" L
11	A123357	Bank Shaver/Router Bit, Reversible, L & R
12	AFN-00012	Nut: 1" NC
13	AFN-00019	Nut: 7/8" NC
18	A125019	Grease Fitting 1/4 x 28.54 Long
19	A125026	Bulkhead nut 1/8 n.p.s.m.
20	A123309-89	Single Hole Tab
21	A125022	18" Grease Line

Push Off Assembly(155-175-1200)

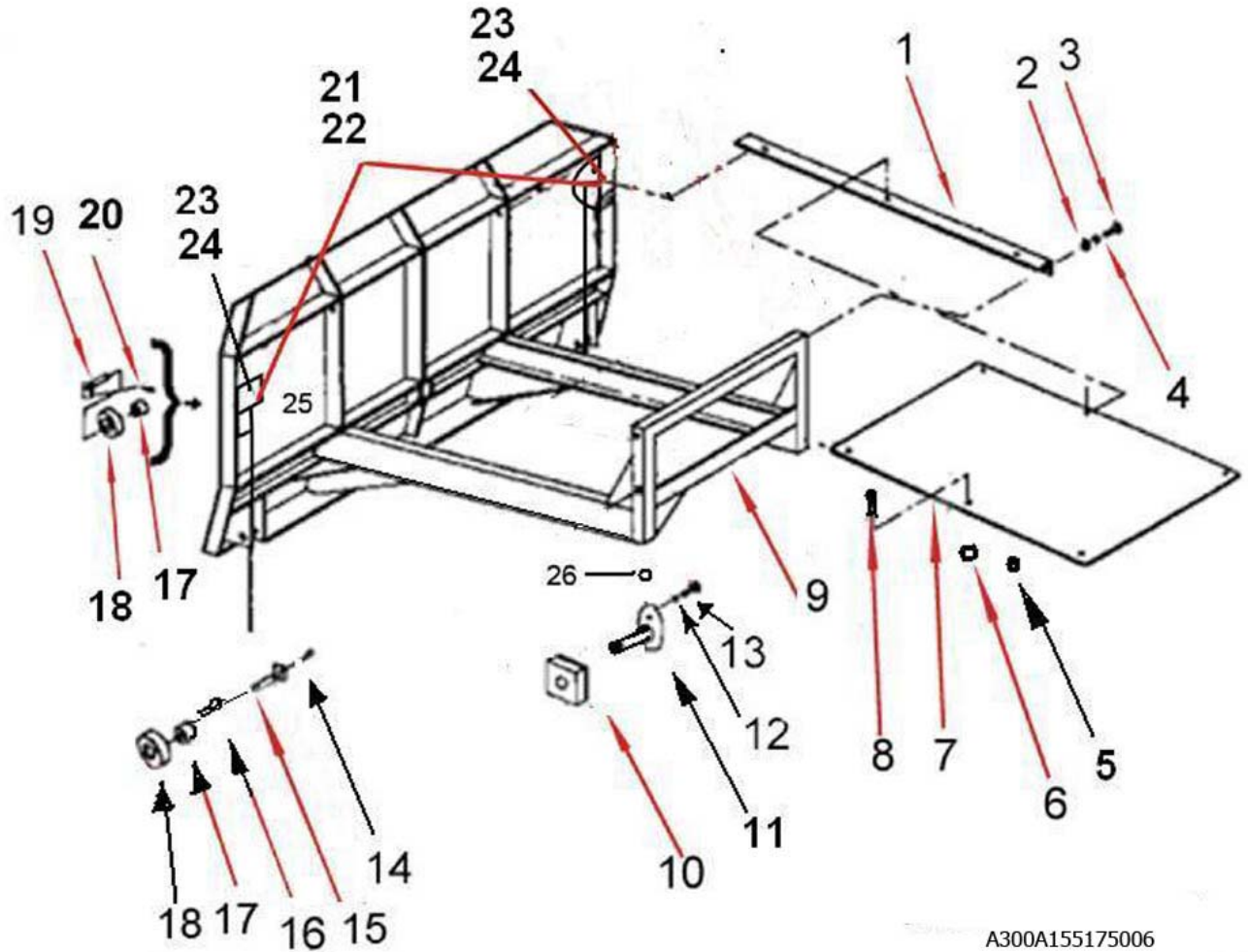

A300A155175006

KEY	PART	DESCRIPTION
1	A14022	Brace
2	AFN-00006	Nut: 3/4" NC
3	AFB-00037	Bolt: 3/4" NC x 2" Lg.
4	AFW-00002	Lockwasher: 3/4"
5	8100	Lockwasher: 1/2"
6	AFN-00015	Nut: 1/2" NC
7	A14023	Dirt Shield
8	AFB-00015	Bolt: 1/2" NC x 1-1/2"
9	A17502	Pushoff Gate: Model 175
10	A123353	Wear Pad
11	A123305A	Pin: 1 1/4 X 2 3/4" for Wear Pad
12	8100	Lockwasher: 1/2"
13	AFB-00033	Bolt: 1/2 NC X 2-1/2"
14	AHF-00028	Grease Fitting: 1/8" NPT -90 degree
15	A6007A	Pin: 1-1/4" x 4-1/8" Lg.
16	AFP-00001	Cotter Pin: 1/4 X 3-1/2"



PHONE : 715-682-4622 Fax: 715-682-9717

ASHLAND SCRAPERS

Push Off Assembly(155-175-1200)

KEY	PART	DESCRIPTION
17	A10163	Bushing: 1-3/4" OD x 1-1/4" ID
18	A10164	Roller: 4-1/4 OD X 1-3/4 ID.
19	A123323-21	Pin: 1-1/4 X 4 1/8" Tab Head
20	7036	Bolt: 1/2 NC X 2"
21	A125020	Remote Grease Lines, 32"
22	A125021	Remote Grease Lines, 54"
23	A125019	Grease Fitting 1/4 x 28.54 Long
24	A125026	BulkHead Nut
25	A123323-40	Double Hole Tab
26	7500	1/2" Nut

ASHLAND SCRAPERS

Pole & Axle Assembly (155-175)

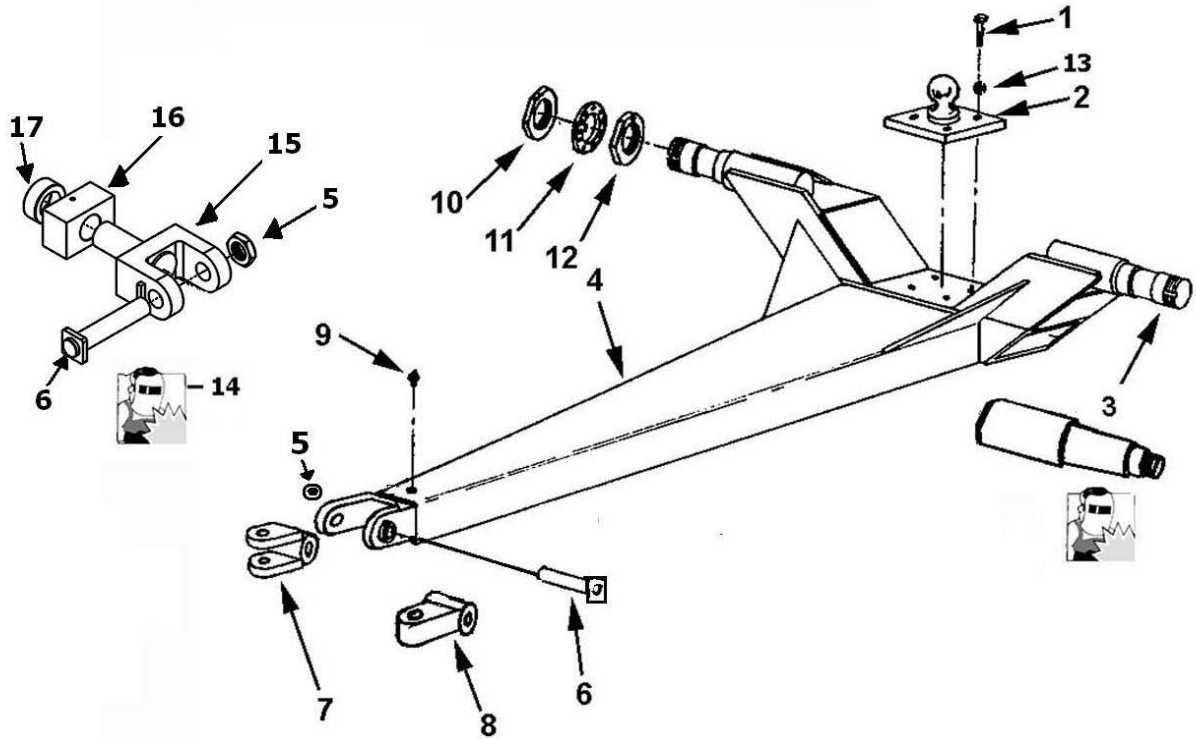

A300A1551753005

KEY	PART	DESCRIPTION
1	AFB-00018	Bolt, 1" NC X 3" Lg.
2	A14017	Ball Swivel
3	A14021	Spindle, weld on
4	A123375	Pole W/20.5 X 25 Tires
5	AFN-00040	Nut, Swivel Pin
6	600055	Pin, Swivel Hitch
7	A17511	Swivel Hitch, Double Lip
8	A17510	Swivel Hitch Single Lip
9	14505	Grease Fitting
10	A10048	Spindle Nut
11	A10049A	Lock Collar
12	A10172	Nut with Lock Pin
13	A123232A	Swivel Hitch Rebuild Kit, includes items 5,6,15,16,17
14	AFW-00006	Lockwasher 1"
15	A123232-3	Hitch: Yoke Assembly
16	A123232-2	Swivel Block 4x6x3
17	A123232-1	Hitch: Retaining Collar

ASHLAND SCRAPERS

Front Wheel Assembly (175)

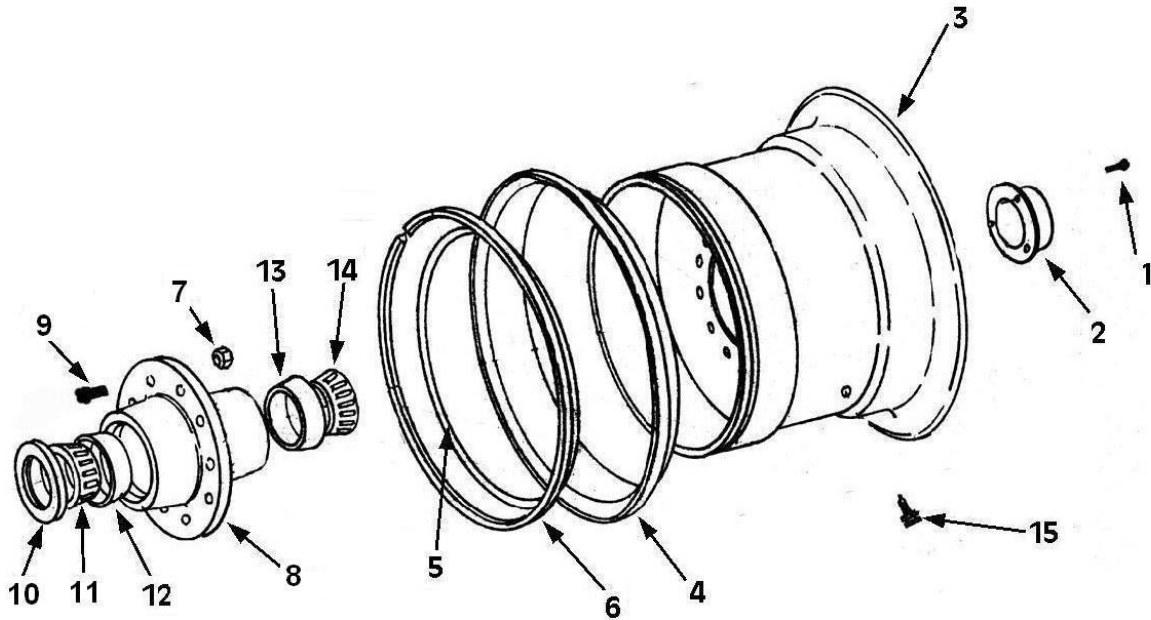

SXL300A155175009F

KEY	PART	DESCRIPTION
2	A14004	Hub Cap
3	A14035	Wheel 17" x 25" 10 Hold Split Rim
4	A14036	Side Ring for 17" x 25" Wheel
5	A14008	"O" Ring
6	A14038	Lock Ring
7	A10046	Lug Nut
8	A14010	Hub
9	A10176	Stud
10	A14011	Grease Seal
11	A14012	Bearing Cone
12	A14013	Bearing Cup
13	A14014	Bearing Cup
14	A14015	Bearing Cone
15	A14016	Valve Stem

ASHLAND SCRAPERS

Rear Wheel Assembly (155-175-1200)

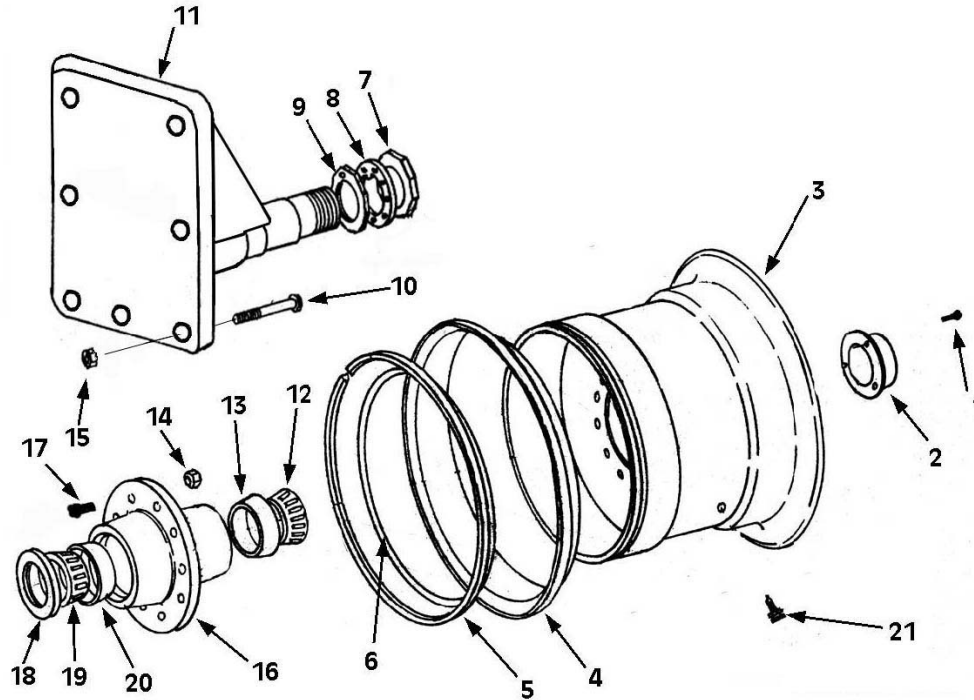

A300A155175009R

KEY	PART	DESCRIPTION
1	AFB-00080	Bolt 5/16" NC x 1/2" Lg.
2	A14004	Hub Cap
3	A12036	Wheel Ass'y. 25" x 25"
4	A12041	Side Ring
5	A12042	Lock Ring
6	A12047	O-Ring
7	A10048	Spindle Nut
8	A10049A	Lock Collar
9	A10172	Nut with Lock Pin
10	AFB-00067	Bolt 1-1/4" NF X 7-1/2" Lg.
11	A123350	Spindle
12	A125001	Bearing Cone
13	A125002	Bearing Cup
14	A12051	Lug Nut
15	AFN-00009	Lock Nut: 1-1/4" NF
16	A12035	Hub
17	A12050	Lug
18	A12037	Grease Seal
19	A125003	Bearing Cone
20	A125004	Bearing Cup
21	A14016	Valve Stem

ASHLAND SCRAPERS

Apron Cylinder (#A125050) 4" X 13"

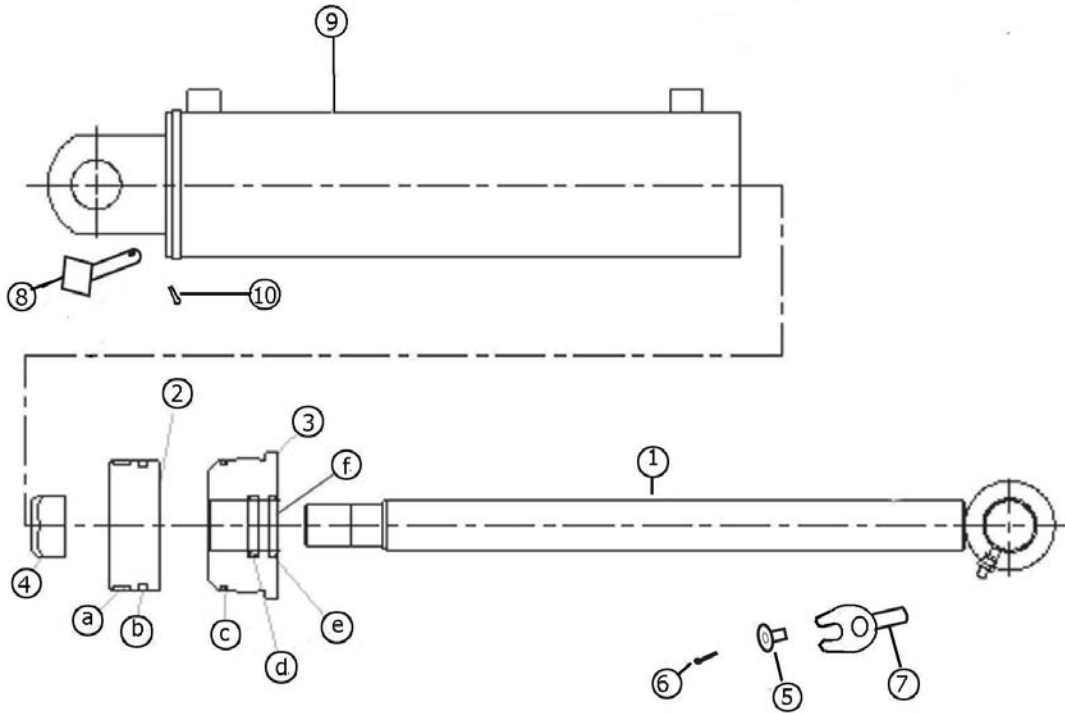

A350P004

KEY	PART	DESCRIPTION
1	A125050-01	Rod 1-3/4" with welded eye
2	A125050-02	Piston
3	A125050-03	Gland, Threaded
4	A125050-04	Lock Nut, 1-1/8" NF
5	A123351	Pin Keeper Bushing
6	AFB-00019	1/2" x 1 1/2" Gr 8 Bolt
7	A123362	Pin: Cyl. Rod End 1 1/2 X 4 1/2 w/ Tab
8	A123363	Pin: Cyl. Base End 1 1/2 X 4 1/8"
9	A125050-06	Cylinder Barrel
10	8602	Cotter Pin: 1/4 X 2
	A125050-05	Seal Kit Containing (a-f)
a		Nylon Wear Ring
b		FSP Seal
c		O-Ring
d		Backup Washer
e		Hallite Rod Seal
f		Snap in Rod Wiper

ASHLAND SCRAPERS

Lift Cylinder (#A520H275) 5" X 20"

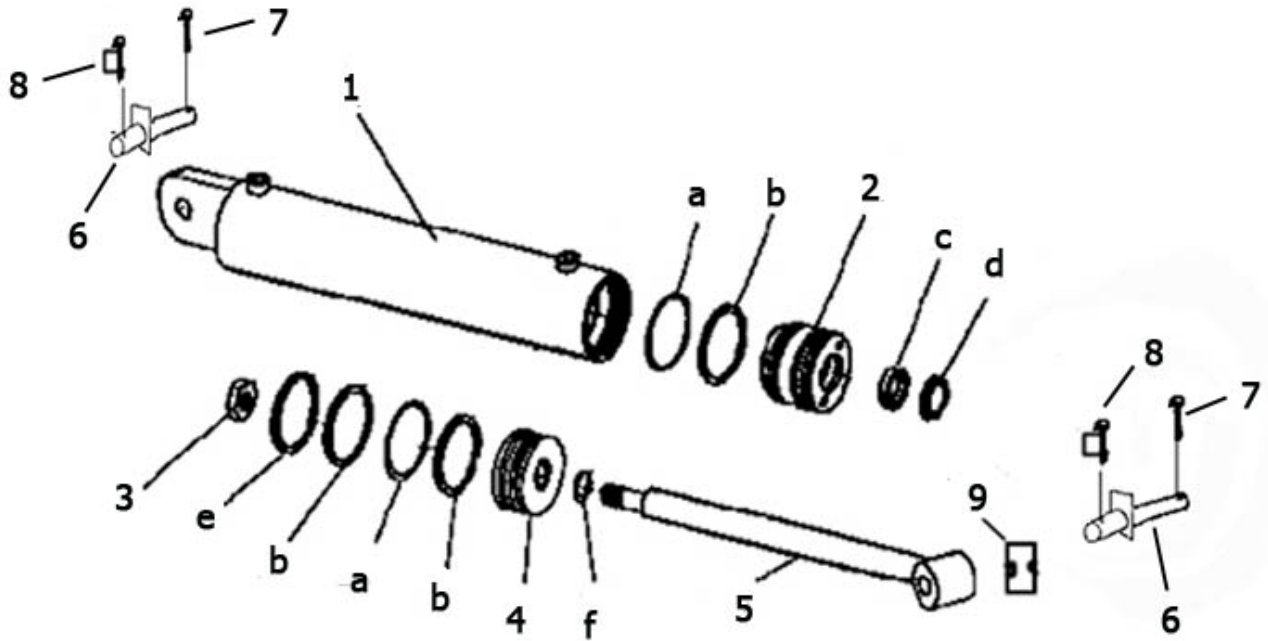

M155X350P001

KEY	PART	DESCRIPTION
2	A80H05A	Head Gland
3	A400H17	Nut 1-1/4" NF, Lock Type
4	A80H01	Piston, 5" OD
5	A80H32	Shaft 2" Dia.
6	A123335	Pin, lower
7	AFP-00001	Cotter Pin, 1/4" x 3"
8	A125006	SafetySnap Pin
9	A123231-88	Spacer for lower Pin
10	A123372	Pin, upper
	A80H07	Packing Kit, Containing: (1) A400H04 (1) A60H52 (3) A400H05 (1) A80H04, (2) A400H06 (1) A80H06
a	A400H06	"O" Ring, 5" OD x 1/4"
b	A400H05	"Back-up Washer, 5" OD x 1/4"
c	A80H04	Seal 2" ID
d	A80H06	Wiper Seal 2" ID
e	A400H04	Cast Ring, 5" OD
f	A60H52	"O" Ring, 1-1/4" OD x 1/16"
18	14505	Grease fitting

ASHLAND SCRAPERS

Push Off Cylinder (#A125178) 4" X 60"

4" X 60" Stroke

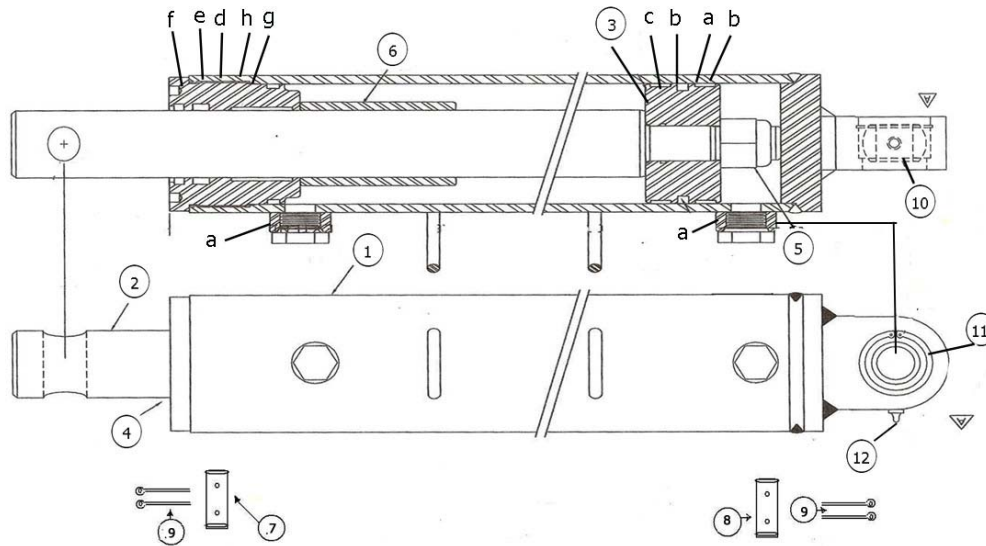

A350P003

KEY	PART	DESCRIPTION
1	A123360-01	Barrel
2	A123360-02	Rod
3	A123360-03	Piston
4	A123360-04	Head Gland
5	A123360-05	Lock Nut
6	A123360-07	Spacer Sleeve
7	A123323-38	Rod End Pin 5-1/16 x 1-1/2
8	A123323-41	Barrel End Pin 4 9/16 X 1 1/2
9	AFP-00001	1/4 x 3 Cotter Pin
10	A125178-35	Bushing
10	A125175-37	Grease Zerk
11	A125178-36	Snap ring
12	14505	Grease Fitting 1/8 NPT st
	A123360-16	Seal Kit (including a-h)
a		Piston Seal
b		Wear Ring
c		O-Ring
d		Wear Ring
e		Rod Seal
f		Wiper
g		O-Ring
h		Back-up Ring

ASHLAND SCRAPERS

Hydraulic Manifold (#A125174)

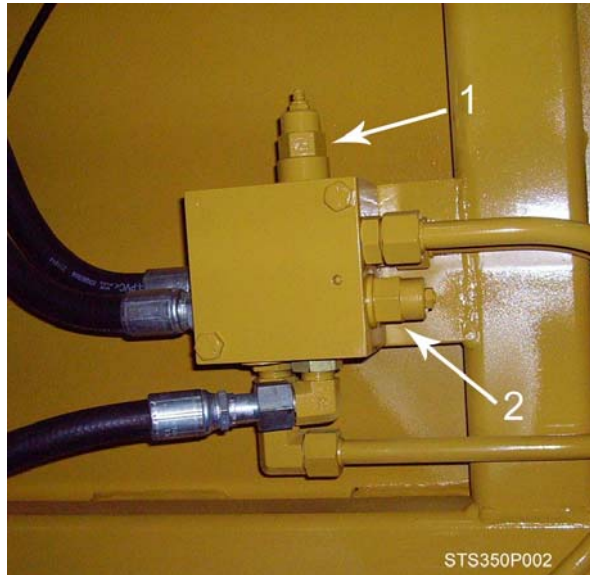

KEY	PART	DESCRIPTION
1	A125162-02	PUSHOFF SEQUENCE CARTRIDGE
2	A125162-01	COUNTER BALANCE CARTRIDGE

SETTING THE APRON AND PUSHOFF VALVE

The manifold block containing the pushoff sequence valve cartridge and apron sequence valve cartridge is used to control two hydraulic circuits with one hydraulic remote. When the tractor hydraulic remote is activated, oil flows first to the apron cylinders until they are fully extended. Once the cylinders are fully extended, the apron circuits' hydraulic pressure begins to increase. Once the pressure threshold is surpassed (which is adjustable. See adjustment section), the sequence valve diverts the oil flow to the pushoff's hydraulic circuit. Once the push off is completely extended the operator then reverses the tractors hydraulic remote. The counterbalance valve will hold the apron open until the push off is fully retracted. The Apron sequence valve then opens and allows the apron to close.

Setting the valves:

STEP 1 PUSHOFF SEQUENCE VALVE

Loosen the lock nut (9/16") on the sequence valve cartridge. Turn the setscrew (4mm) clockwise until the front apron rises before the push-off begins to advance. (Earthmover should be empty) Turn the adjustment screw an additional 1/4 turn clockwise and tighten jam nut.

STEP 2 COUNTER BALANCE VALVE

Loosen the lock nut (9/16") on the counterbalance valve cartridge. Turn the setscrew (4mm) counter-clockwise until the apron holds in a raised position while rear gate is being retracted. Turn adjustment screw an additional 1/4 turn, tighten jam nut. DO NOT tighten adjusting screw more than necessary.

ASHLAND SCRAPERS

Hydraulic Valve Ports Assembly

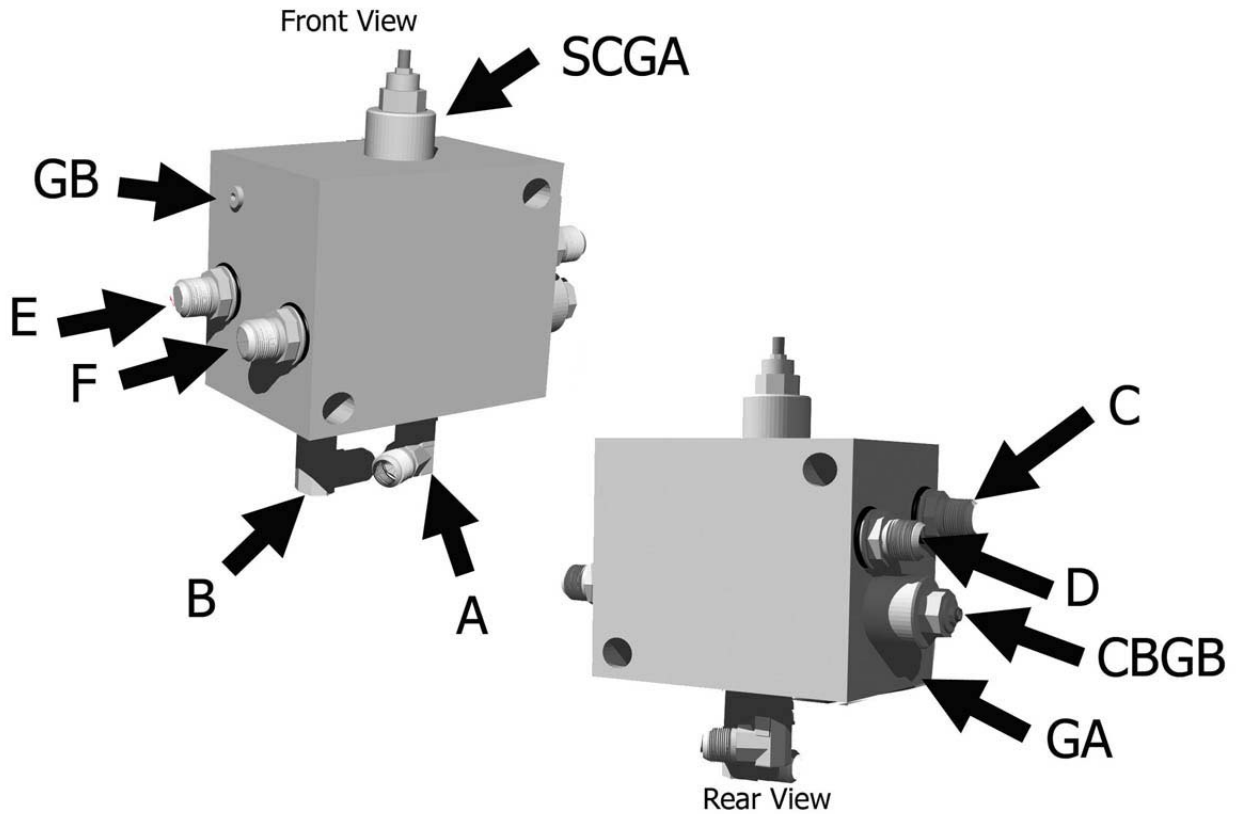

The lettering for the port locations are stamped on the block

A350P010

KEY	PART	DESCRIPTION
A		Supply Line
B		Pushoff Cyl. (Rod End)-Apron Cyl., Right side (Rod end)-Supply Line
C		Pushoff Cylinder, (Base End)
D		Apron Cylinder, Right side, (Base End)
E		Apron Cylinder, Left side, (Rod End)
F		Apron Cylinder, Left side, (Base End)
CBGB		Counterbalance Valve, adjustable
SCGA		Sequence Valve, adjustable
GA		Pressure test port
GB		Pressure test port

ASHLAND SCRAPERS

Hydraulic Valve Seals

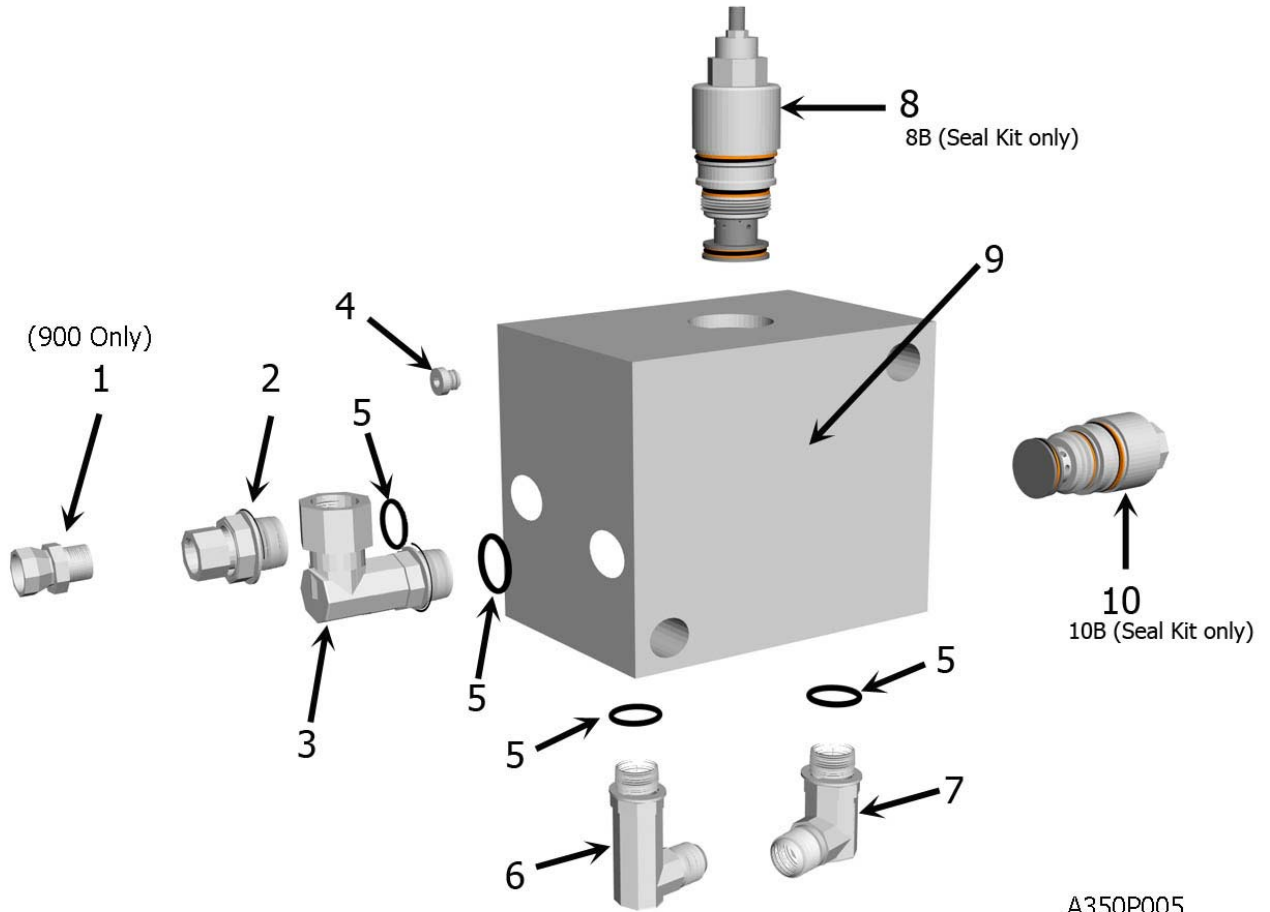

A350P005

KEY	PART	DESCRIPTION
2	AHA-00043	Adapter: Str. Sw. 1 1/16 M ORB X 1/2 FP
3	AHA-00048	Adapter: 90 Deg. Swiv. 1 1/6 M ORB X 1/2 FP
4	AHA-00046	6 ORB Plug
5	AHS-00153	O-Ring for 12 M ORB Fitting
6	AHA-00047	Adapter: 90 Deg. XL 3/4 MJX 1 1/6 M ORB
7	AHA-00044	Adapter: 90 Deg. 3/4 MJ X 1 1/6 M ORB
8	A125162-02	Valve: Sequence Cartridge for Ver. III & IV
9	A125174	Valve: Manifold Block IV Body
10	A125162-01	Valve: Counterbalance Cartridge for Ver. III & IV
	A125162-01 KIT	Seal Kit for A125162-01 Valve Cartridge
	A125162-02 KIT	Seal Kit for A125162-02 Valve Cartridge



PHONE : 715-682-4622 Fax: 715-682-9717

ASHLAND SCRAPERS

Decals

KEY	PART	DESCRIPTION
1	ADS-00001	Large Ashland
2	ADS-00002	Small Ashland
3	ADS-00009	I-175
6	ADS-00014	XL2
7	ADS-00003	Black Wedge, Gradient
8	ADS-STRIPEKIT	Black Stripe Kit
9	ADS-00019	Grease
10	750464	High Pressure Fluid Hazard
11	ADS-00011	Pinch Point

ASHLAND SCRAPERS

Decals Illustration (I-175XL2)

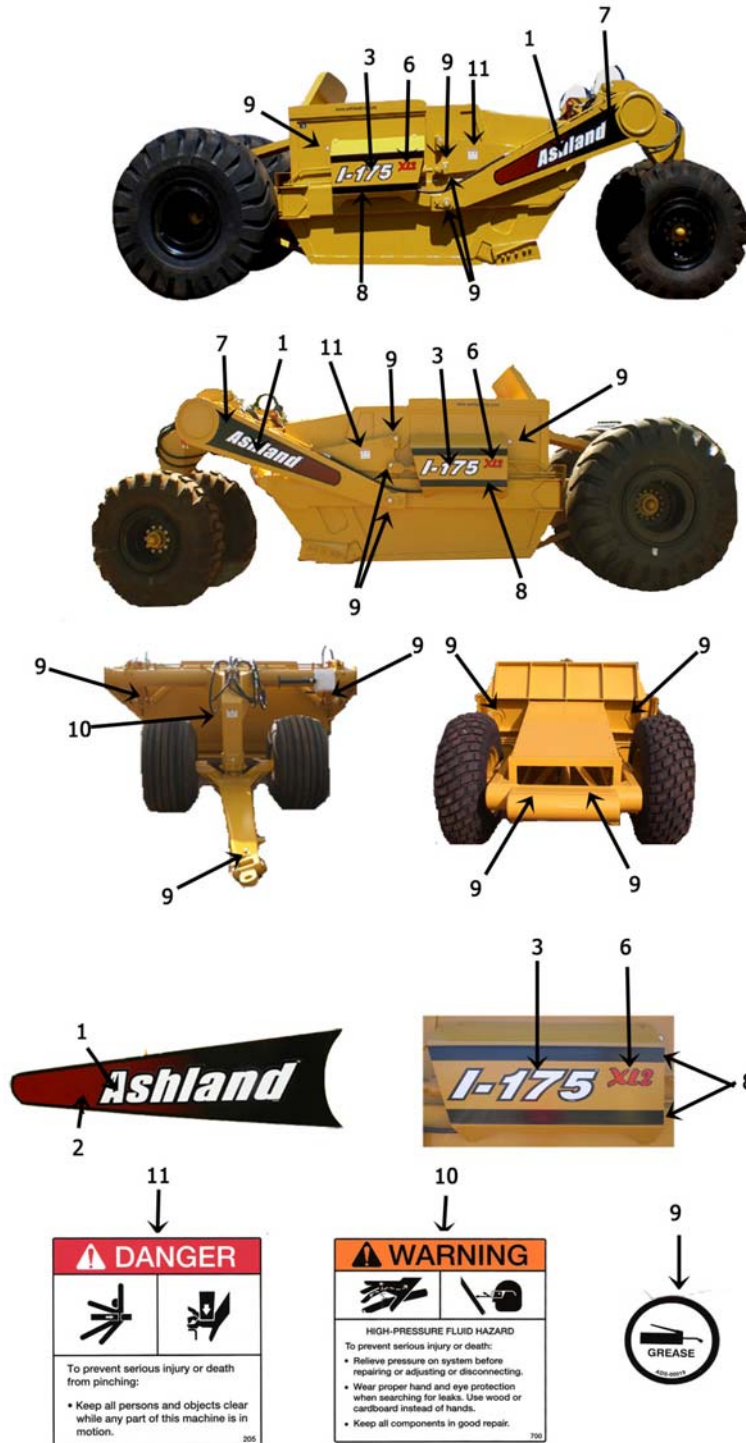

M130X100SD003

ASHLAND SCRAPERS

Maintenance Check list

1. Grease all zerks.
 - a) Every 8 hours of operation.
 - b) See Lubrication Points section on next page.
2. Greasing the hubs.
 - a) Re-pack wheel bearings after 600 hrs of operation.
 - b) Completely clean grease out of hub and bearings every 1200 hours of operation.
3. Check tire pressure.
 - a) 20.5 - 25, 12-ply tire requires a tire pressure of 35-40 psi on a rear machine, 40-50 on a front machine.
4. Check all pins for signs of wear.
 - a) Daily
5. Check wheel lug nut torque.
 - a) After first 2 hours of operation.
 - b) Recheck daily for next 2 weeks.
 - c) Tighten wheel lug nuts in a star pattern.
 - d) Torque wheel lug nuts to 450 ft-lbs.
6. Check and retighten all bolts.
 - a) After initial 10 hours of use.
 - b) Again after 50 hours of use.
 - c) See Torque Specifications on next page.
7. Inspect cutting edges.
 - a) Daily
 - b) Replace cutting edges when center blade has been worn to approximately 6" and side edges worn to approximately 4".



CAUTION! Failure to replace worn cutting edges may result in unnecessary wear to the earthmover sides and floor.

Note: Please specify left or right "L" shaped cutting edges when ordering replacements. Left or right side parts are determined by viewing from rear of the scraper.

ASHLAND SCRAPERS

Pushing the Earthmover



PUSHING THE EARTHMOVER

This scraper was designed to be pushed when equipped with the optional push-bar. However, Ashland Industries, Inc. **STRONGLY** recommends using extreme caution when pushing the earthmover to prevent any unnecessary damage.

CAUTION! The earthmover must be pushed in a straight line with a maximum of a 100 hp dozer. Do not ram or jar the earthmover while pushing and push at a constant speed.

ASHLAND SCRAPERS

Tire Service



The task of servicing tires and wheels can be extremely dangerous and should be performed by trained personnel only, using the correct tools and following specific procedures. Do not attempt to mount, demount or inflate a tire if you do not have the proper equipment and experience to perform the job. Call a qualified repair service to inspect the assembly and make necessary repairs. Failure to heed warnings could lead to serious injury or death.

Visually inspect tires and wheels daily. Carefully inspect any rim and tire assembly that has been run underinflated or flat before reinflating the tire to make sure there is no damage to either the rim or tire.

- ALWAYS wear personal protection equipment such as gloves, footwear, eye protection, hearing protection and head gear when servicing tire and wheel components.
- DO NOT operate with damaged rims, tire cuts or bubbles, missing lug bolts or nuts or damaged rims.
- ALWAYS maintain the correct tire pressure. NEVER exceed recommended tire inflation pressure.
- INSPECT any rim and tire assembly that has been run flat or severely underinflated before reinflating the tire. Damage to the rim and tire may have developed.
- NEVER inflate a tire that has lost air pressure or has been run flat without determining and correcting the problem.
- NEVER try to repair wheel, rim, or tire components parts. Parts that are cracked, worn, pitted with corrosion, or damaged must be discarded, and replaced with good parts.
- ALWAYS use approved tire and rim combinations for the model scraper that you have and verify that part numbers of components are correctly matched for the assembly.
- ALWAYS exhaust all air from the tire prior to demounting.
- ALWAYS place wheel and tire assemblies in restraining devices (safety cage) when inflating tires. Use a clip-on chuck and long extension hose to allow you to stand to the side of the tire and not in front of it.
- NEVER weld or cut on an inflated tire assembly. Welding heat can cause increased pressure which could result in tire explosion.
- ALWAYS use proper lifting techniques, and mechanized lifting aids to move heavy components and assemblies.
- NEVER leave a tire, wheel, or assembly unsecured in a vertical position.
- ALWAYS take care when moving tires and wheels that other people in the area are not endangered.

ASHLAND SCRAPERS

Torque Specifications

TORQUE SPECIFICATIONS

<i>Bolt</i>	<i>Torque</i>		
<i>Diameter</i>	<i>Ft-lbs</i>		
<i>1/4</i>	<i>12</i>		
<i>5/16"</i>	<i>25</i>		
<i>3/8"</i>	<i>45</i>		
<i>7/16"</i>	<i>70</i>		
<i>1/2"</i>	<i>110</i>		
<i>9/16"</i>	<i>150</i>		
<i>5/8"</i>	<i>220</i>		
<i>3/4"</i>	<i>380</i>		
<i>7/8"</i>	<i>600</i>		
<i>1"</i>	<i>900</i>		
<i>1-1/8"</i>	<i>1280</i>		
<i>Lug Nuts</i>	<i>85-100 /9 yd</i>	<i>450- 11/13 yd</i>	<i>750-15 yd & up</i>

LUBRICATION

1. Grease all zerks every 8 hrs of operation with high quality, general-purpose grease.
 - a) Grease until grease flows from around pin.

Lubrication Points (see III.)

1. Hitch – Horizontal and vertical pins.
2. Lift Cylinders – Rod end & Trunion; Both left & right sides.
3. Front Arm Pivot Joint – Both left & right sides.
4. Apron Cylinders – Rod clevis pin; Both left & right sides.
5. Apron Pivot Pin – Both left & right sides.
6. Hold-down Rollers – Both left & right sides.
7. Floor Rollers – Both left & right sides.
8. Tapered Rollers – Both left & right sides.

ASHLAND SCRAPERS

Troubleshooting

Introduction

With proper care and maintenance, your Ashland Scraper will give many years of reliable service. When a situation arises where the earthmover performance is not satisfactory, this section will give some pointers on finding and correcting the problem.

Grease zerk will not take grease.

1. Grease zerk plugged.
 - a) Remove and replace grease zerk.
 2. Pin is frozen.
 - a) Remove, clean, and inspect pin.
 - b) Replace pin if necessary.
 3. Bushing grease passage is not aligned with grease zerk.
 - a) Remove, clean, inspect, and realign bushing.
 - b) Replace bushing if necessary and realign.
-

Push-off rollers do not roll.

1. The rollers need lubrication.
 - a) Check zerk hole and grease.
 - b) Remove pin, clean, inspect, and replace if necessary.
 2. The roller bushing is worn out.
 - a) Remove roller assembly and replace bushing.
 - b) See parts manual.
-

Cylinders will not hold in preset position, i.e. the cylinder creeps.

1. Seals leaking internally.
 - a) Remove and replace seal kit.
-

Machine cuts unevenly.

1. Cutting edges worn unevenly.
 - a) Replace cutting edges.
 2. Improperly inflated tires.
 - a) Check air pressure in tires.
-



ASHLAND SCRAPERS

Warranty Statement

Limited Warranty Statement

Ashland Industries Inc. warrants each new product to be free from defects in material and workmanship. This warranty is applicable only for the normal service life expectancy of the product or components, not to exceed **six consecutive months** from the date of delivery of the new Ashland Industries product to the purchaser, or the date the product is first put into service via a rental agreement or other means, whichever occurs first.

The major components of swivel hitches used on Industrial series scrapers are warranted for three consecutive months from the date of delivery of the new Ashland Industries product to the purchaser, or the date the product is first put into service via a rental agreement or other means, whichever occurs first, except those components described below.

Genuine Ashland Industries Inc. replacement parts and components will be warranted for 30 days from date of purchase, or the remainder of the original equipment warranty period, whichever is longer.

Under no circumstances will it cover any merchandise or components thereof, which in the opinion of the company, has been subjected to misuse, unauthorized modification, alterations, an accident or if repairs have been made with parts other than those obtained through Ashland Industries Inc.

Ashland Industries Inc. in no way warrants Tires since their respective manufacturer warrants these items separately. Please call Ashland Industries Inc. to receive phone numbers of tire suppliers.

Ashland Industries Inc. in no way warrants wearable items such as cutting edges, front dolly wheel balls, socket halves, rollers, bushings, yoke hitch pins, hitch bushings, etc..

Our obligation under this warranty shall be limited to repairing or replacing, free of charge to the original purchaser, any part that, in our judgment, shall show evidence of such defect, provided further that such part shall be returned within 30 days from the date of failure to Ashland Industries Inc. routed through the dealer and distributor from whom the purchase was made, transportation charges prepaid. Upon warranty approval proper credits will be reimbursed for transportation.

This warranty shall not be interpreted to render Ashland Industries Inc. liable for injury or damages of any kind or nature to person or property. This warranty does not extend to the loss revenue, extra labor cost associated with downtime, substitute machinery, rental or for any other reason.

Except as set forth above, Ashland Industries Inc. shall have no obligation or liability of any kind on account of any of its equipment and shall not be liable for special or consequential damages. Ashland Industries Inc. make no other warranty, expressed or implied, and, specifically, Ashland Industries Inc. disclaims any implied warrant or merchantability or fitness for a particular purpose. Some states or provinces do not permit limitations or exclusions of implied warranties or incidental or consequential damages, so the limitations or exclusion in this warranty may not apply.

This warranty is subject to any existing conditions of supply which may direct affect our ability to obtain materials or manufacture replacement parts.

Ashland Industries Inc. reserves the right to make improvements in design or changes in specifications at any time, without incurring any obligation to owners of units previously sold.

No one is authorized to alter, Modify or enlarge this warranty nor the exclusion, limitations and reservations.

Ashland Industries Inc.
Warranty Department