

Ashland **INDUSTRIES, INC.™**



I-175XL2 PARTS MANUAL

Version 3-03

Ashland Industries Inc.
1115 Rail Drive
P.O. Box 717
Ashland, WI. 54806
Ph: 877-634-4622 *Toll Free*
Ph: 715-682-4622
Fx: 715-682-9717
www.ashlandind.com





HOW TO ORDER PARTS:

IMPORTANT

Parts must be ordered through your local authorized ASHLAND dealer.

Be sure to state MODEL and SERIAL NUMBER of your machine, PART NUMBER, DESCRIPTION and QUANTITY needed.

Unless this is done, we cannot provide prompt service or assure shipment of the correct parts.



Ashland Industries weldable replacement parts are available to rebuild, modify or update your scraper to current factory specifications.

INDEX

Page 3.	Operators and Maintenance Instructions
Page 4.	Safety Guidelines
Page 5.	Illustration - Assembly
Page 6.	Illustration and Parts List - Gooseneck Frame Assembly
Page 7.	Illustration and Parts List - Apron Assembly
Page 8-9.	Illustration and Parts List - Bowl and Frame Assembly
Page 10.	Illustration and Parts List - Push Off Gate Assembly
Page 11.	Illustration and Parts List - Pole and Axle Assembly
Page 12.	Illustration and Parts List - Front Wheel and Hub Assembly
Page 13.	Illustration and Parts List - Rear Wheel and Hub Assembly, Std.
Page 14.	Illustration and Parts List - Rear Wheel and Hub Assembly, Optl.
Page 15.	Illustration and Parts List - Hydraulic Cylinder, 4" x 13", Apron
Page 16.	Illustration and Parts List - Hydraulic Cylinder, 5" x 20"
Page 17-18.	Illustration and Parts List - Hydraulic Cylinder, 4-½" x 60"
Page 19.	Illustration and Parts List - Counterbalance Valve
Page 20.	Illustration and Parts List - Sequence Valve
Page 21.	Hydraulic Valve Adjustment Instructions
Page 22-24.	Service Manual Appendix
Page 25-26.	Troubleshooting
Page 27.	Warranty Statement

OPERATORS AND MAINTENANCE INSTRUCTIONS

This scraper is a durable piece of equipment and with proper care will yield many years of trouble free operation. The scraper requires a power source with TWO 4 way (double acting) hydraulic control valves.

The scraper should be greased at all points where grease fittings are provided. Connect hydraulic hoses to the tractor and retract lift cylinders to REMOVE TRANSPORT LOCK PINS (point A), then extend and retract all cylinders several times to force out any air from the hydraulic cylinders and lines. Check the oil levels in the tractor hydraulic system and add to maintain the proper level. Care should be used when adding oil or when disconnecting any oil line to keep all dirt out of the oil as dirt is a major factor in the failure of hydraulic components.

When the scraper is placed into operation, the operator will have to “feel out” the amount of depth of cut to obtain maximum loading efficiency. This is usually accomplished by taking a lesser and more uniform cut; however, some soil conditions such as loose sand may require a “pumping action” obtained by taking successive deep cuts and lifting out of cut as the tractor begins to lose power or traction.

1. After 10 hours work, all bolts should be checked and tightened if necessary.
2. Every 10 hours all grease fittings should be lubricated.
3. After 50 hours work, all bolts should be rechecked and tightened if necessary. Check wheel bearings and adjust if necessary.
4. After 300 hours work, clean and repack wheel bearings and replace, if necessary, cutting edges, worn pins, etc.



SAFETY SIGNAL WORDS

Note the use of the signal words DANGER, WARNING and CAUTION with the safety messages. The appropriate signal word for each has been selected using the following guidelines:

DANGER: Indicates an imminently hazardous situation that, if not avoided, will result in death or serious injury. This signal word is to be limited to the most extreme situations typically for machine components which, for functional purposes, cannot be guarded.



WARNING: Indicates a potentially hazardous situation that, if not avoided, could result in death or serious injury, and includes hazards that are exposed when guards are removed. It may also be used to alert against unsafe practices.



CAUTION: Indicates a potentially hazardous situation that, if not avoided, may result in minor or moderate injury. It may also be used to alert against unsafe practices.



GENERAL SAFETY GUIDELINES

Safety of the operator is one of the main concerns in designing and developing a new piece of equipment. Designers and manufacturers build in as many safety features as possible. However, every year many accidents occur which could have been avoided by a few seconds of thought and a more careful approach to handling equipment. You, the operator, can avoid many accidents by observing the following precautions in this section. To avoid personal injury, study the following precautions and insist those working with you, or for you, follow them.

Replace any CAUTION, WARNING, DANGER or instruction safety decal that is not readable or is missing. Location of such decals is indicated in this booklet.

Do not attempt to operate this equipment under the influence of drugs or alcohol.

Review the safety instructions with all users annually.

This equipment is dangerous to children and persons unfamiliar with its operation. The operator should be a responsible adult familiar with farm machinery and trained in this equipment's operations. Do not allow persons to operate or assemble this unit until they have read this manual and have developed a thorough understanding of the safety precautions and of how it works.

To prevent injury or death, use a tractor equipped with a Roll Over Protective System (ROPS). Do not paint over, remove or deface any safety signs or warning decals on your equipment. Observe all safety signs and practice the instructions on them.

Never exceed the limits of a piece of machinery. If its ability to do a job, or to do so safely, is in question - DON'T TRY IT.

ILLUSTRATION * ASSEMBLY

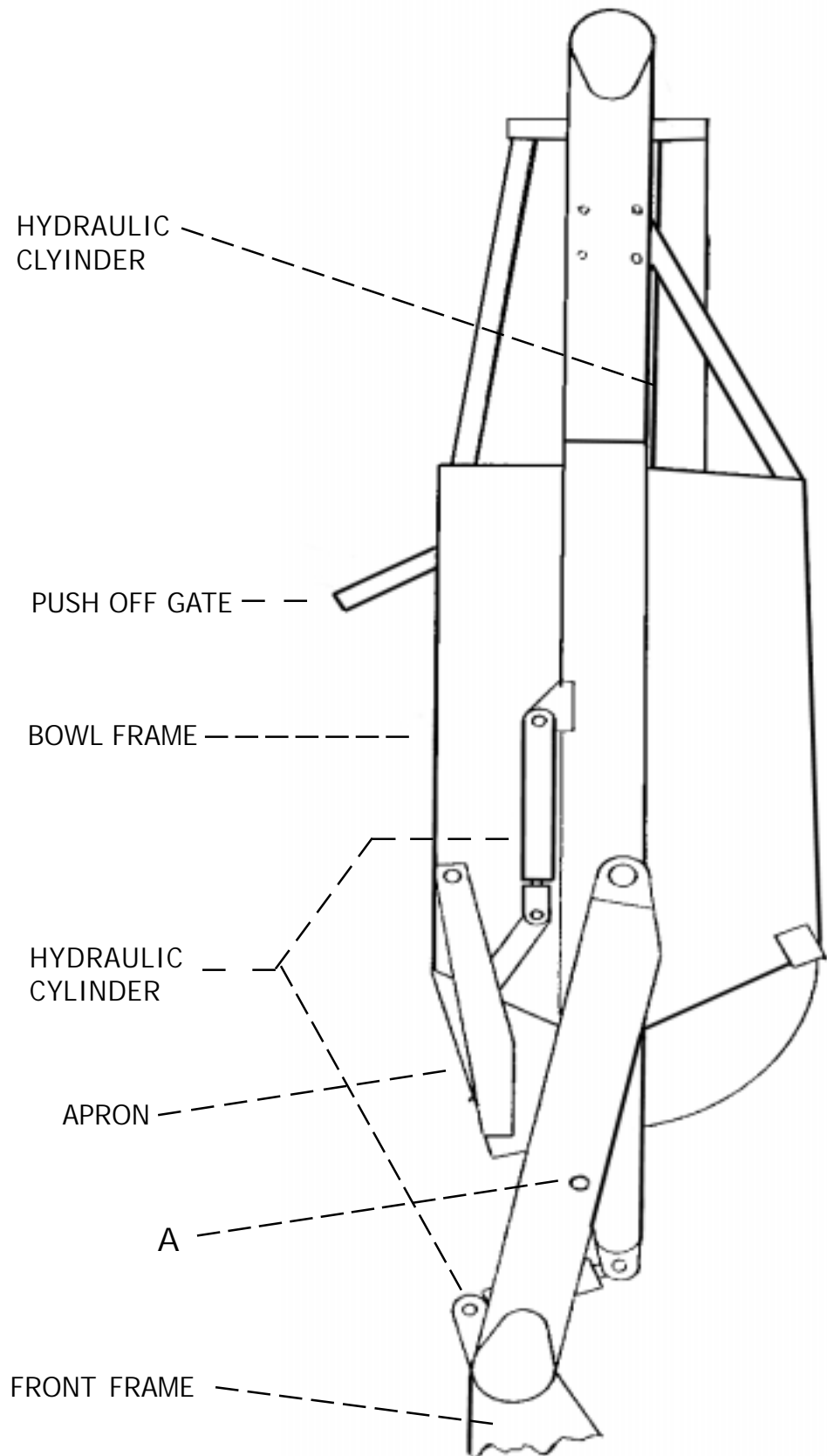

GOOSENECK FRAME ASSEMBLY

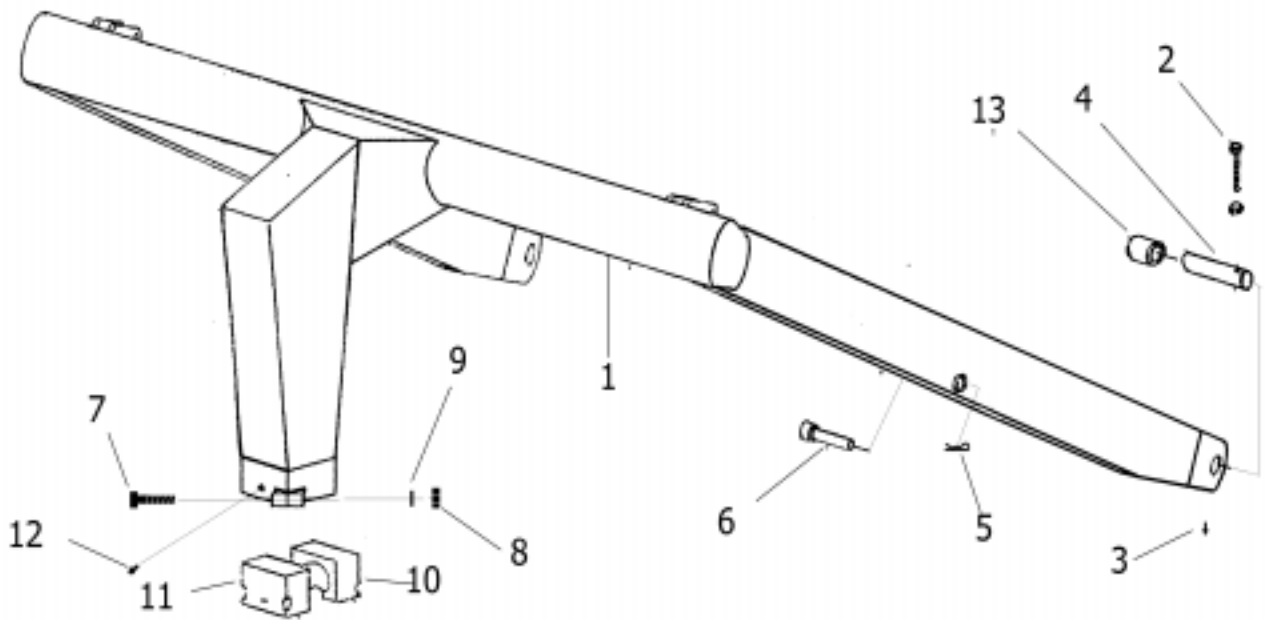

PARTS LIST GOOSENECK FRAME ASSEMBLY MODEL I-175 XL2

KEY NO.	PART NO.	DESCRIPTION
1.	A17507	Gooseneck Frame
2.	AFB-00054	Bolt, 1/2" NC x 3-1/2" Lg.
3.	14505	Grease Zerk - Straight
4.	A17508	Pin, Frame Attach
5.	-----	Hair Pin
6.	AFB-00018	Bolt, Transport Lock, 1" NC x 3"
	AFN-00012	Nut: 1" NC
7.	AFB-00022	Bolt, 7/8"NF x 4-1/2" Lg. Grade 5
8.	7597	Nut, 7/8"NF
9.	8125	Lockwasher 7/8"
10.	A14002	Cast Socket Half - Rear
11.	A14003	Cast Socket Half - Front w/Zerk Hole
12.	A2206	Grease Zerk - Long Shank
13.	A17509	Bushing, 2-3/4" OD x 2-1/4" ID x 2" Long

APRON ASSEMBLY

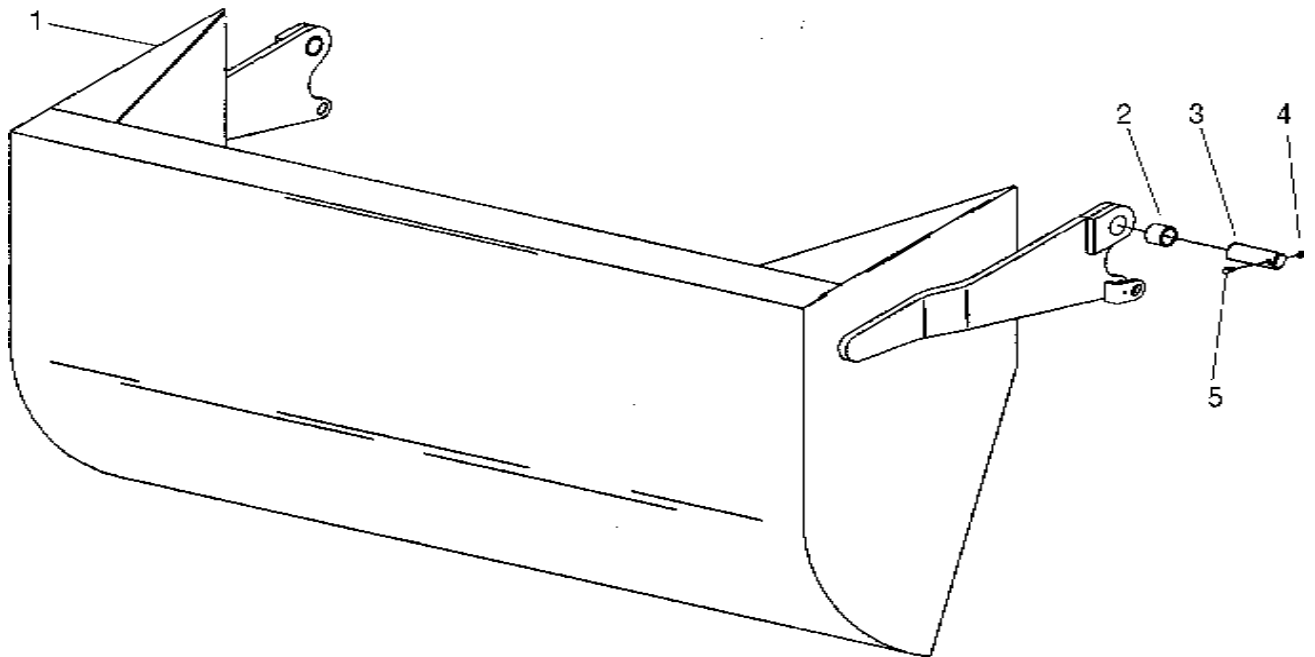

PARTS LIST APRON ASSEMBLY MODEL I-175 XL2

KEY NO.	PART NO.	DESCRIPTION
1.		Apron Model I-175 XL
2.	A16027	Bushing: 2" OD x 1-1/2" ID x 2" Long
3.	A123337	Pin: 1-1/2" x 5-3/8"
4.	7450	Nut: 3/8" NC
5.	AFB-00049	Bolt: 3/8" NC x 3"

BOWL and FRAME ASSEMBLY

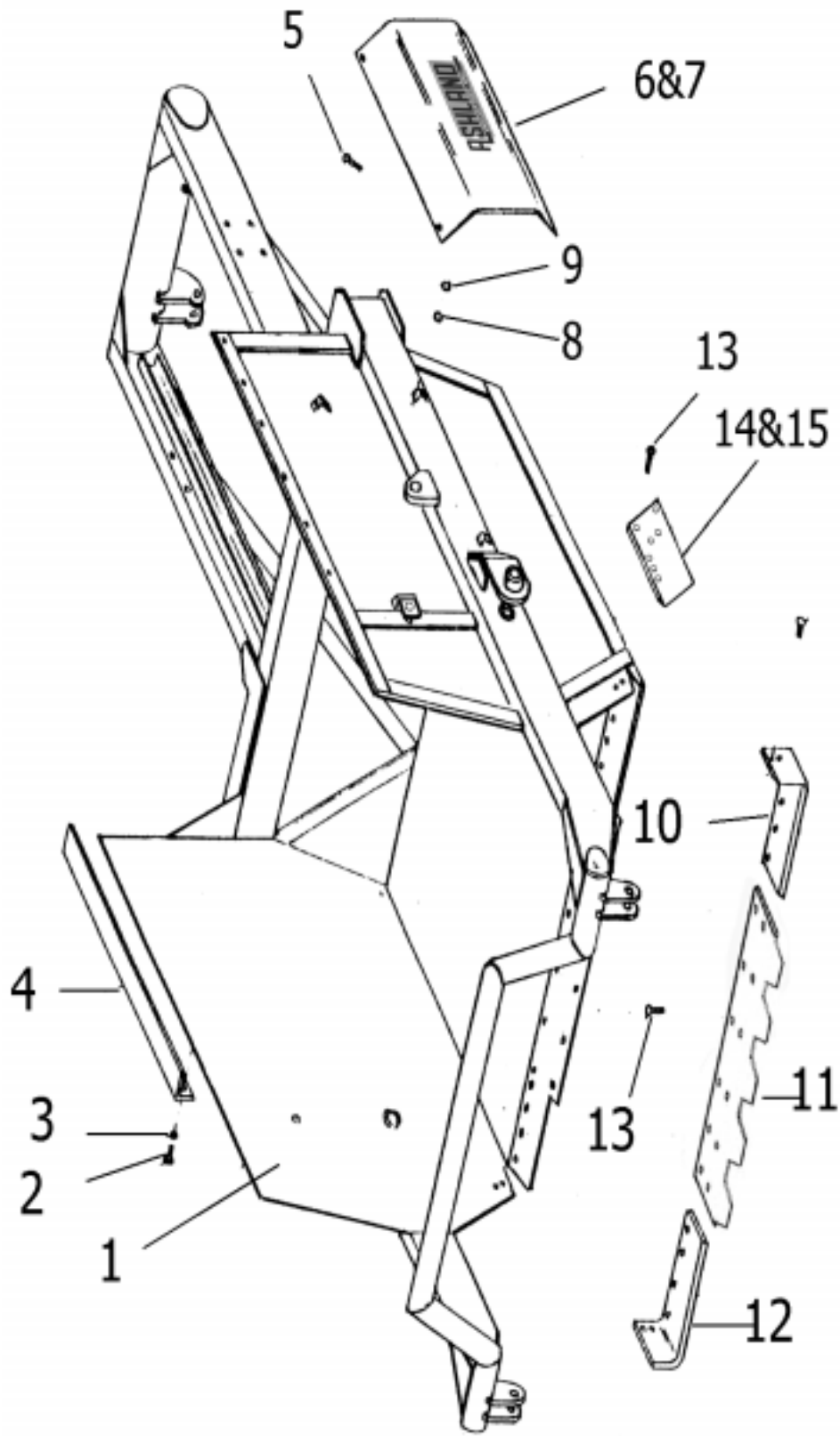

PARTS LIST
BOWL and FRAME ASSEMBLY
MODEL I-175XL2 SCRAPER

KEY NO.	PART NO.	DESCRIPTION
1.	A17503	Bowl and Frame, Model I-175XL2 w/Std. Tires (Consult factory if equipped w/ 29.5 x 25 tire option)
2.	-----	Capscrew 5/8"NC x 1-1/4" Lg.
3.	-----	Lockwasher 5/8"
4.	A17504	Gate Containment Angle
5.	AFB-00034	Bolt 3/8"NC x 1" Lg.
6.	A10157	Cylinder Guard - Left Hand
7.	A10158	Cylinder Guard - Right Hand
8.	7450	Nut 3/8" NC
9.	8078	Lockwasher 3/8"
10.	A123332L PB9P-NC-088-0275 AFN-00019	Left Cutting Edge Plow Bolt: 7/8 NC X 2-3/4" -> 6 Required Nut: 7/8" NC -> 6 Required
11. 13.	A123330SER PB9P-NC-088-0275 AFN-00019	Center Cutting Edge, Serrated Plow Bolt: 7/8 NC X 2-3/4" -> 12 Required Nut: 7/8" NC -> 12 Required
12.	A123332R PB9P-NC-088-0275 AFN-00019	Right Cutting Edge Plow Bolt: 7/8 NC X 2-3/4" -> 6 Required Nut: 7/8" NC -> 6 Required
14.	A123338L PB9P-NC-088-0275 PB9P-NC-088-0225 AFN-00019 AFN-00026	Left Shaver Bit Plow Bolt: 7/8 NC X 2-3/4" -> 5 Required Plow Bolt: 7/8 NC X 2-1/4" -> 2 Required Nut: 7/8" NC -> 5 Required Nut: 7/8" NC Jam -> 2 Required
15.	A123338R PB9P-NC-088-0275 PB9P-NC-088-0225 AFN-00019 AFN-00026	Right Shaver Bit Plow Bolt: 7/8 NC X 2-3/4" -> 5 Required Plow Bolt: 7/8 NC X 2-1/4" -> 2 Required Nut: 7/8" NC -> 5 Required Nut: 7/8" NC Jam-> 2 Required

PUSHOFF ASSEMBLY

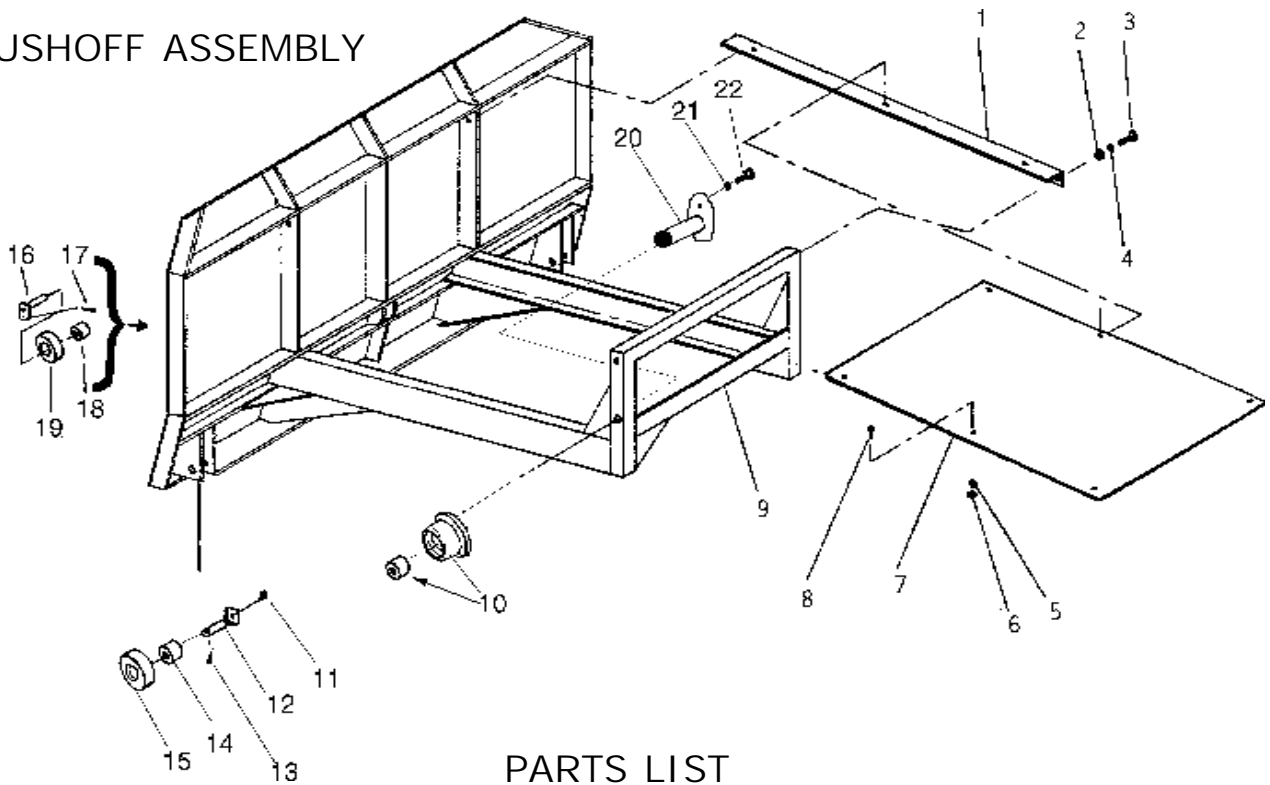

PARTS LIST PUSH OFF ASSEMBLY MODEL I-175XL2

KEY NO.	PART NO.	DESCRIPTION
1.	A14022	Brace
2.	AFN-00006	Nut: 3/4" NC
3.	AFB-00037	Bolt: 3/4" NC x 2" Lg.
4.	AFW-00002	Lockwasher: 3/4"
5.	8078	Lockwasher: 3/8"
6.	7450	Nut: 3/8" NC
7.	A14023	Dirt Shield
8.	AFB-00034	Bolt: 3/8 NC x 1" Lg.
9.	A17502	Pushoff Gate
10.	A123306	Roller: Rear Gate
10A.	A123307	Bushing
11.	AHF-00028	Grease Fitting: 1/8" NPT -90 degree
12.	A6007A	Pin: 1-1/4" x 4-1/8" Lg.
13.	AFP-00001	Cotter Pin: 1/4 X 3-1/2"
14.	A10163	Bushing: 1-3/4" OD x 1-1/4" ID
15.	A10164	Roller: 3-1/2 OD X 1-3/4 ID
16.	A123288	Pin: 1-1/4 X 3-1/4" Tab Head
17.	7036	Bolt: 1/2 NC X 2"
18.	A10163	Bushing: 1-3/4" OD x 1-1/4" ID
19.	A10164	Roller: 3-1/2 OD X 1-3/4 ID
20.	A123305	Pin: 1-1/4 X 2-3/4"
21.	8100	Lockwasher: 1/2"
22.	AFB-00033	Bolt: 1/2 NC X 2-1/2"

POLE and AXLE ASSEMBLY

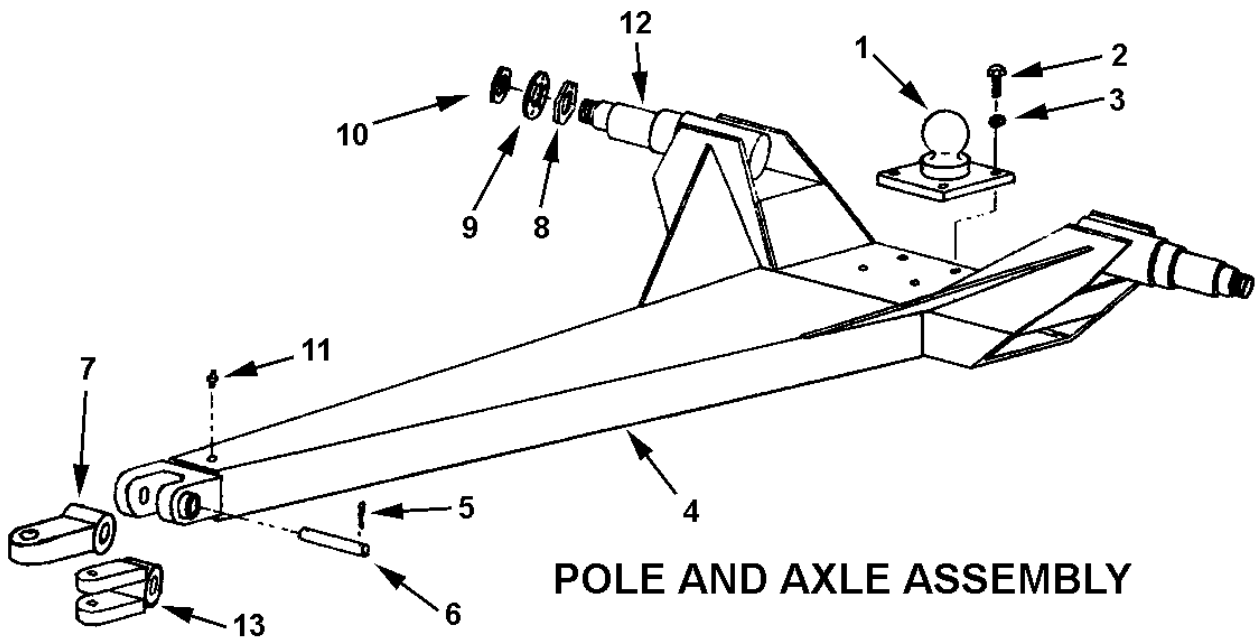

PARTS LIST POLE and AXLE ASSEMBLY MODEL I-175XL2

KEY NO.	PART NO.	DESCRIPTION
1.	A14017	Ball Swivel
2.	AFB-00018	Bolt 1" NC x 3" Long
3.	AFW-00006	Lockwasher 1"
4.	A17501	Pole
5.	AFB-00052	Bolt, 5/16" x 3" Long
	AFN-00016	Nut: 5/16" NC
6.	A14019	Pin 1-3/4" x 7-3/8" Long
7.	A17510	Swivel Hitch Single Lip
8.	A10172	Nut with Lock Pin
9.	A10049A	Lock Collar
10.	A10048	Spindle Nut
11.	14505	Grease Fitting
12.	A14021	Spindle (weld on)
13.	A17511	Swivel Hitch, Double Lip (optional)

FRONT WHEEL and HUB ASSEMBLY

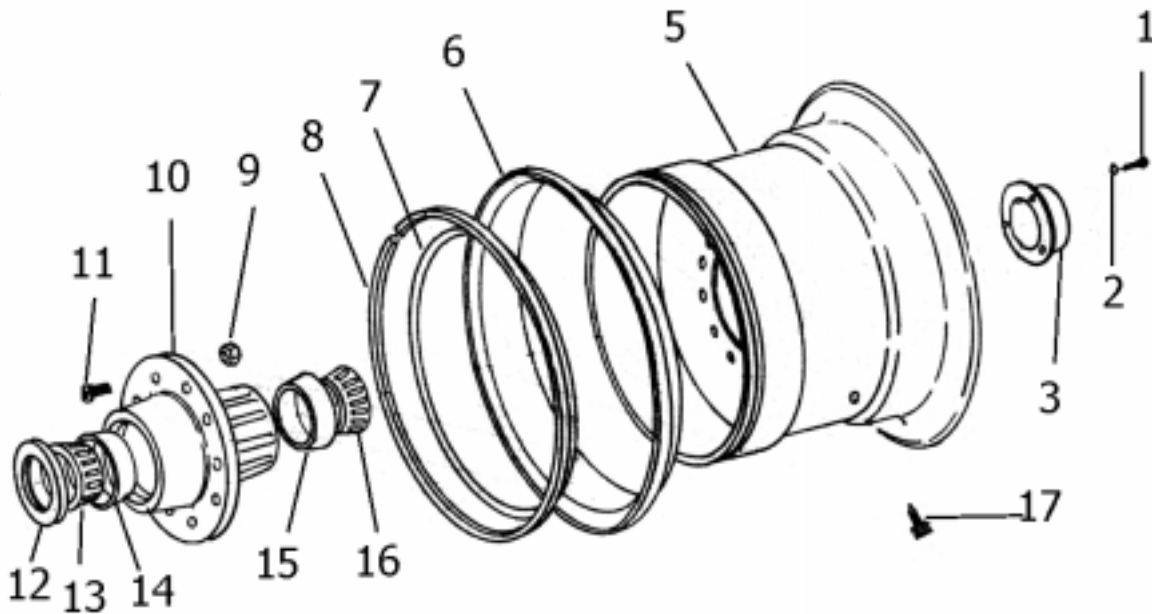

PARTS LIST FRONT WHEEL and HUB ASSEMBLY MODEL I-175XL2

KEY NO.	PART NO.	DESCRIPTION
1.	AFB-00020	Bolt 5/16" NC x 3/4" Lg.
2.	8070	Lockwasher 5/16"
3.	A14004	Hub Cap
5.	A14006A	Wheel 14" x 25"
6.	A14007A	Side Ring for 14" x 25" Wheel
7.	A14008	"O" Ring
8.	A14009	Lock Ring
9.	A10046	Lug Nut
10.	A14010	Hub
11.	A10176	Stud
12.	A14011	Grease Seal (CR 42624)
13.	A14012	Bearing Cone (Timken 749)
14.	A14013	Bearing Cup (Timken 742)
15.	A14014	Bearing Cup (Timken 632)
16.	A14015	Bearing Cone (Timken 644)
17.	A14016	Valve Stem

REAR WHEEL and HUB ASSEMBLY
STANDARD TIRE

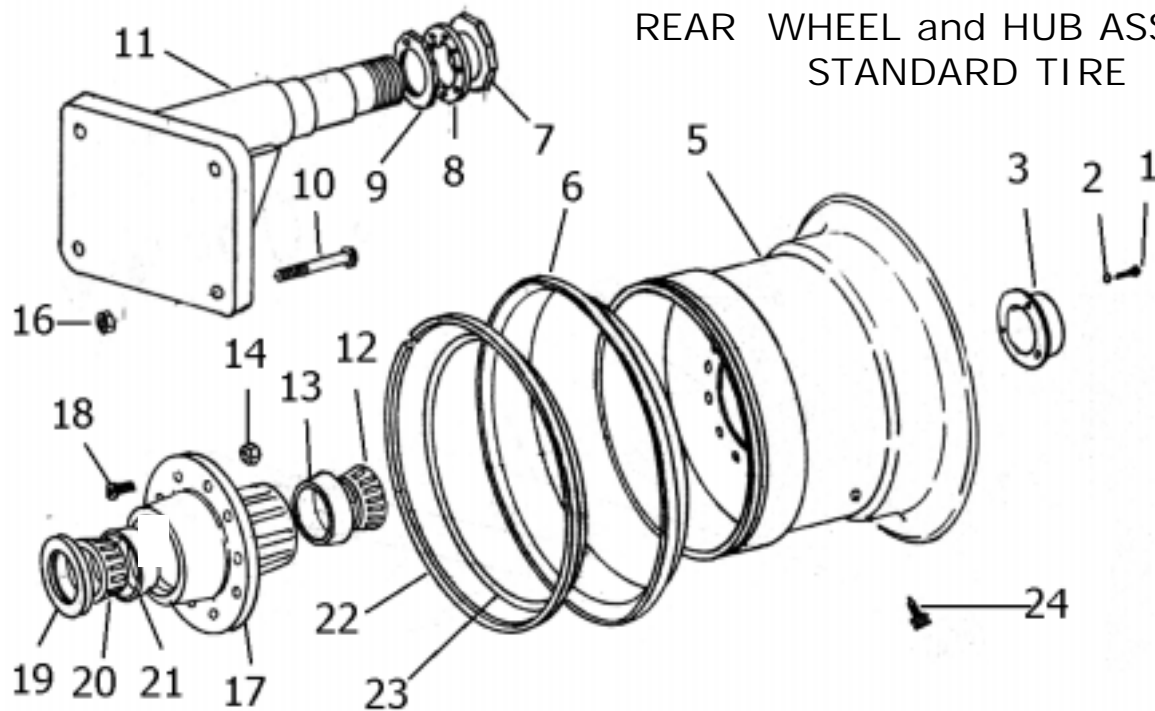

PARTS LIST

REAR WHEEL and HUB ASSEMBLY - STANDARD TIRE
MODEL I-175XL2

KEY NO.	PART NO.	DESCRIPTION
1.	AFB-00020	Bolt 5/16" NC x 3/4" Lg.
2.	8070	Lockwasher 5/16"
3.	A14004	Hub Cap
5.	A14035	Wheel 17" x 25"
6.	A14036	Side Ring
7.	A10048	Spindle Nut
8.	A10049A	Lock Collar
9.	A10172	Nut with Lock Pin
10.	AFB-00024	Bolt 1" NF x 7" Lg.
11.	A14037	Spindle
12.	A14015	Bearing Cone (Timken 644)
13.	A14014	Bearing Cup (Timken 632)
14.	A10046	Lug Nut
15.	AFW-00006	Lockwasher 1"
16.	AFN-00017	Nut 1" NF
17.	A14010	Hub
18.	A10176	Stud
19.	A14011	Grease Seal (CR 42624)
20.	A14012	Bearing Cone (Timken 749)
21.	A14013	Bearing Cup (Timken 742)
22.	A14038	Lock Ring
23.	A14008	"O" Ring
24.	A14016	Valve Stem

REAR WHEEL and HUB ASSEMBLY
w/29.5 x 25 Tire (opt)

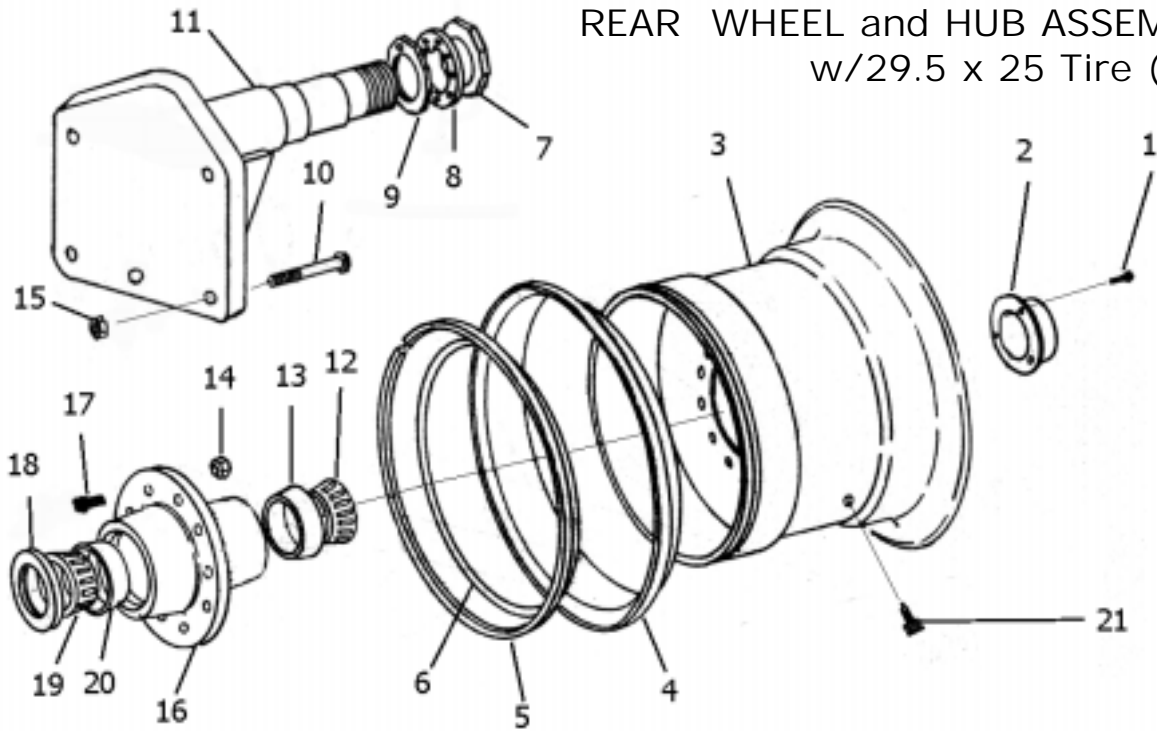

PARTS LIST

REAR WHEEL and HUB ASSEMBLY
MODEL I-175XL2 - w/29.5 X 25 TIRE OPTION

KEY NO.	PART NO.	DESCRIPTION
1.	AFB-00020	Bolt 5/16" NC X 3/4" Lg.
2.	A14004	Hub Cap
3.	A12036	Wheel Ass'y. 25" x 25"
4.	A12041	Side Ring
5.	A12042	Lock Ring
6.	A12047	O-Ring
7.	A10048	Spindle Nut
8.	A10049A	Lock Collar
9.	A10172	Nut with Lock Pin
10.	AFB-00059	Bolt 1-1/4" NF X 7" Lg.
11.	A12044	Spindle
12.	A14015	Bearing Cone (Timken# 644)
13.	A14014	Bearing Cup (Timken# 632)
14.	A12051	Lug Nut
15.	AFN-00009	Lock Nut: 1-1/4" NF
16.	A12035	Hub
17.	A12050	Lug
18.	A12037	Grease Seal (National# 416039)
19.	A12038	Bearing Cup (Timken# 854)
20.	A12039	Bearing Cone (Timken#861)
21.	A14016	Valve Stem

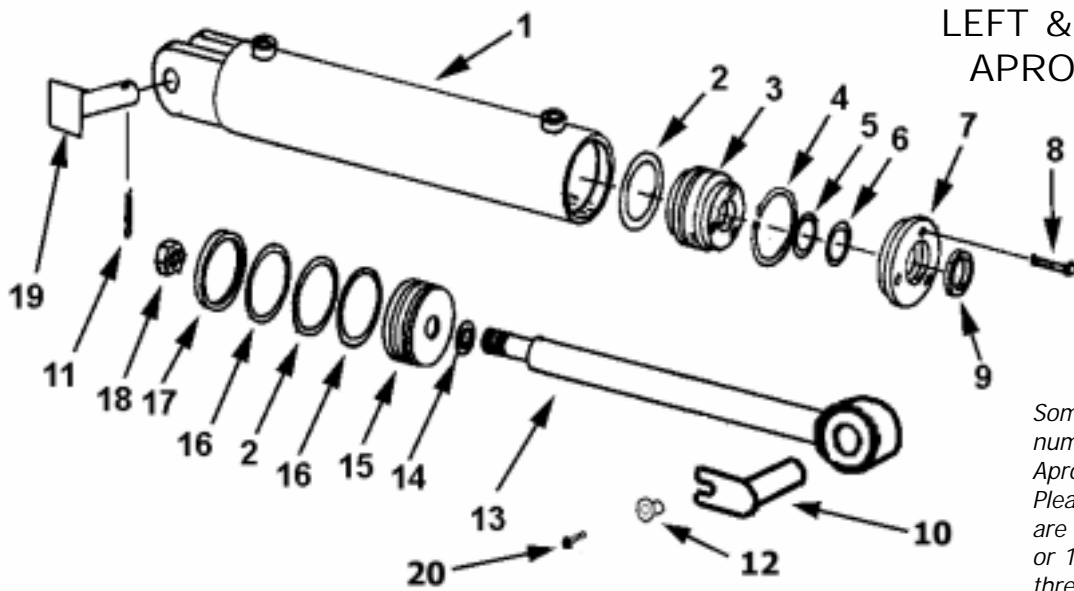

LEFT & RIGHT SIDE
APRON CYLINDER
4 X 13

IMPORTANT

Some units prior to this serial number were upgraded to a H.D. Apron Cylinder by the customer. Please determine if the cylinder pins are 1-1/2" diameter. If pins are 1" or 1-1/4" and is inserted into a thread block ear on the rod end please refer to page 17.

MODEL I-175XL2
LEFT & RIGHT SIDE APRON CYLINDER 4 X 13
PART NO. A123365

KEY NO.	PART NO.	DESCRIPTION
1.	A123365-05	Cylinder Barrel
2.	A300H06	O-Ring: 4" OD x 3/16"
3.	A300H11	Head Gland
4.	A300H12	Retainer Ring
5.	A22H15	O-Ring: 1-1/2" ID x 1/8"
6.	A22H15A	Backup Washer: 1-1/2"
7.	A300H13	Gland Cap
8.	A22H18	Capscrew: 1/4" NC x 1"
9.	A22H17	Wiper Seal: 1-1/2" ID
10.	A123362	Pin, 1-1/2" with slot for keeper bushing
11.	8602	Pin, Cotter 1/4" x 2" Zinc
12.	A123351	Bushing, retaining flange, 9/16" ID x 3/4" OD, 3/4" L
13.	A123367	Rod, S/N 20497 + Welded Eye with 1-1/2" Hole
<i>** If your unit has thread block type rod end see following page **</i>		
14.	A45H05	Piston Gasket: 1"
15.	A300H07	Piston: 4" Dia.
16.	A300H05	Backup Washer: 4" OD
17.	A300H04	Cast Iron Ring: 4" OD
18.	A300H03	Piston Nut, 1" NF
19.	A123363	Pin: 1-1/2" square head
20.	AFB-00015	HHCS 1/2" NC x 1-1/2" Gr. 8
	A300H14B	Packing Kit, Containing:
	(1) A300H04	(2) A22H15
	(2) A300H05	(1) A22H15A
	(2) A300H06	(1) A22H17
	(1) A45H05	

HYDRAULIC CYLINDER - A520H118 5" X 20"
LIFT CYLINDER

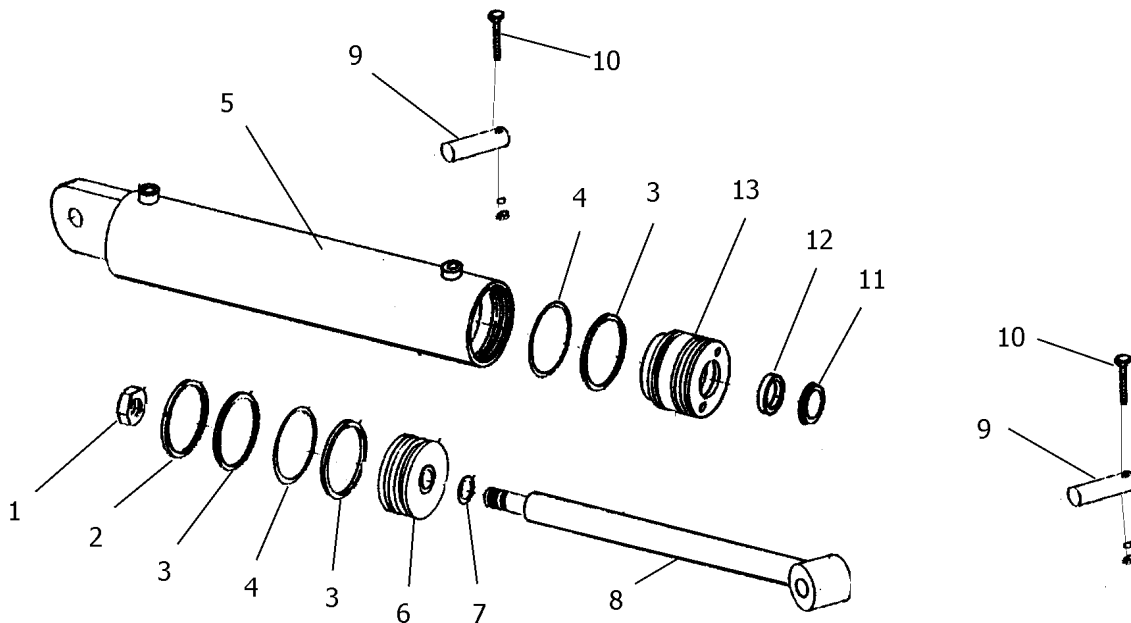

PARTS LIST
LIFT CYLINDER

KEY NO.	PART NO.	DESCRIPTION
1.	A400H17	Nut 1-1/4" NF, Lock Type
2.	A400H04	Cast Ring, 5" OD
3.	A400H05	Back-up Washer, 5" OD x 1/4"
4.	A400H06	"O" Ring, 5" OD x 1/4"
5.	A80H02A	Barrel Assembly with 1-1/4" holes
6.	A80H01	Piston, 5" OD
7.	A60H52	"O" Ring, 1-1/4" OD x 1/16"
8.	A80H08A	Shaft 2" Dia.
9.	A14033	Pin, 1-1/4" x 5" Lg.
10.	-----	Bolt 1/4" NC x 2" Lg. with Nut & Lockwasher
11.	A80H06	Wiper Seal 2" ID
12.	A80H04	Seal 2" ID
13.	A80H05A	Head Gland
	A80H07	Packing Kit, Containing:
	(1) A400H04	(1) A60H52
	(3) A400H05	(1) A80H04
	(2) A400H06	(1) A80H06

HYDRAULIC CYLINDER - A4560H114, 4-1/2" X 60"
MODEL I-175XL2 PUSH OFF CYLINDER

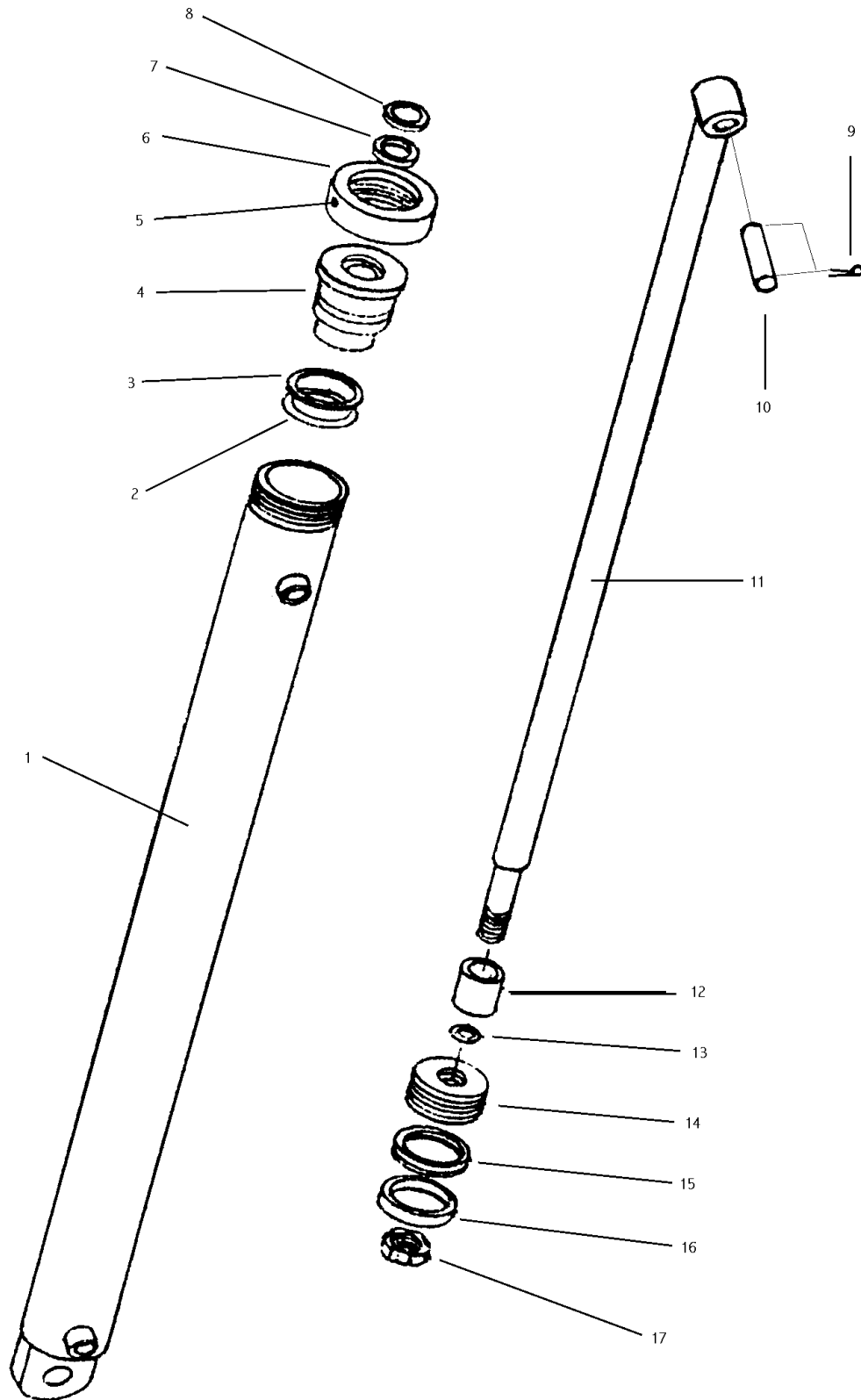

PARTS LIST
 PUSH OFF CYLINDER, A4560H114, 4-1/2" x 60"
 MODEL I-175XL2

KEY NO.	PART NO.	DESCRIPTION
1.	A175H08	Barrel Assembly, 4-1/2" Bore
2.	A175H03	"O" Ring, 4-1/2" OD x 4-1/8" ID
3.	A175H04	Back Up Washer, 4-1/2" OD x 4-1/8" ID
4.	A175H09	Head Gland
5.	-----	Set Screw, 3/8" NC
6.	A175H10	Collar
7.	A140H07	Shaft Seal, 2-1/2" ID, OU-Cup
8.	A140H08	Wiper Seal
9.	-----	Cotter Pin, 3/16" x 2"
10.	A10038	Pin, 1-1/4" Dia. x 4-1/4" Lg.
11.	A175H11	Shaft, 2-1/2" Dia.
12.	A175H06	Spacer
13.	A22H15	"O" Ring, 1-1/2" x 1-3/4" OD
14.	A175H12	Piston
15.	A175H05	Piston Seal, 4-1/2" OD
16.	A175H07	Wear Ring, 4-1/2" OD
17.	AFN-00018	Nut, Lock Type, 1-1/2" NF
	A175H15	Packing Kit, Containing:
		(1) A175H03 (1) A175H04
		(1) A140H07 (1) A140H08
		(1) A22H15 (1) A175H05
		(1) A175H07

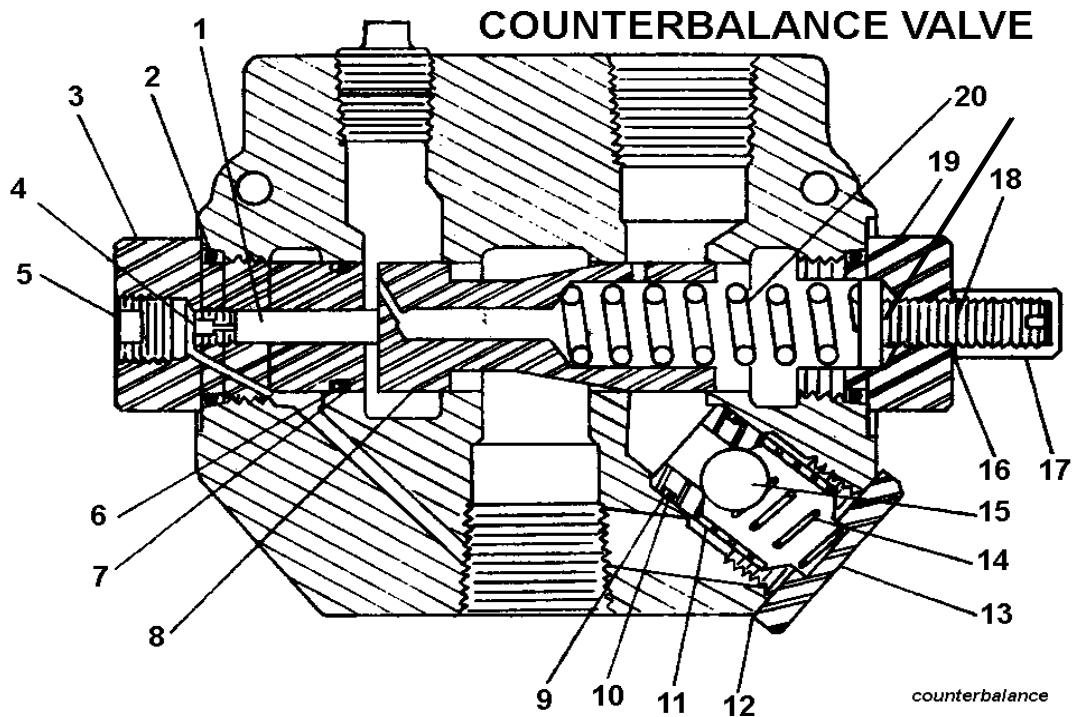

PART NUMBER: A101H47

KEY NO.	PART NO.	DESCRIPTION
1	A101H49	Piston
2	A101H50	O-ring
3	A101H51	External pilot plug
4	A101H52	Orifice
5	A101H53	Plug
6	A101H54	O-ring
7	A101H55	Backup washer
*8	A101H70	Metering spool
9	A101H57	Backup washer
10	A101H58	O-ring
11	A101H59	Check seat
12	A101H60	Aluminum washer
13	A101H61	Check plug
14	A101H62	Check spring
15	A101H63	Check ball
16	A101H64	Aluminum washer
17	A101H65	Acorn nut
18	A101H66	Adjusting screw
19	A101H69	Adjusting plug - RD1075 SM
20	A101H70	Metering spring (High Pressure Spring)
21		O-ring
*	A101H71	Valve body

* NOT SOLD SEPARATELY

SEQUENCE VALVE

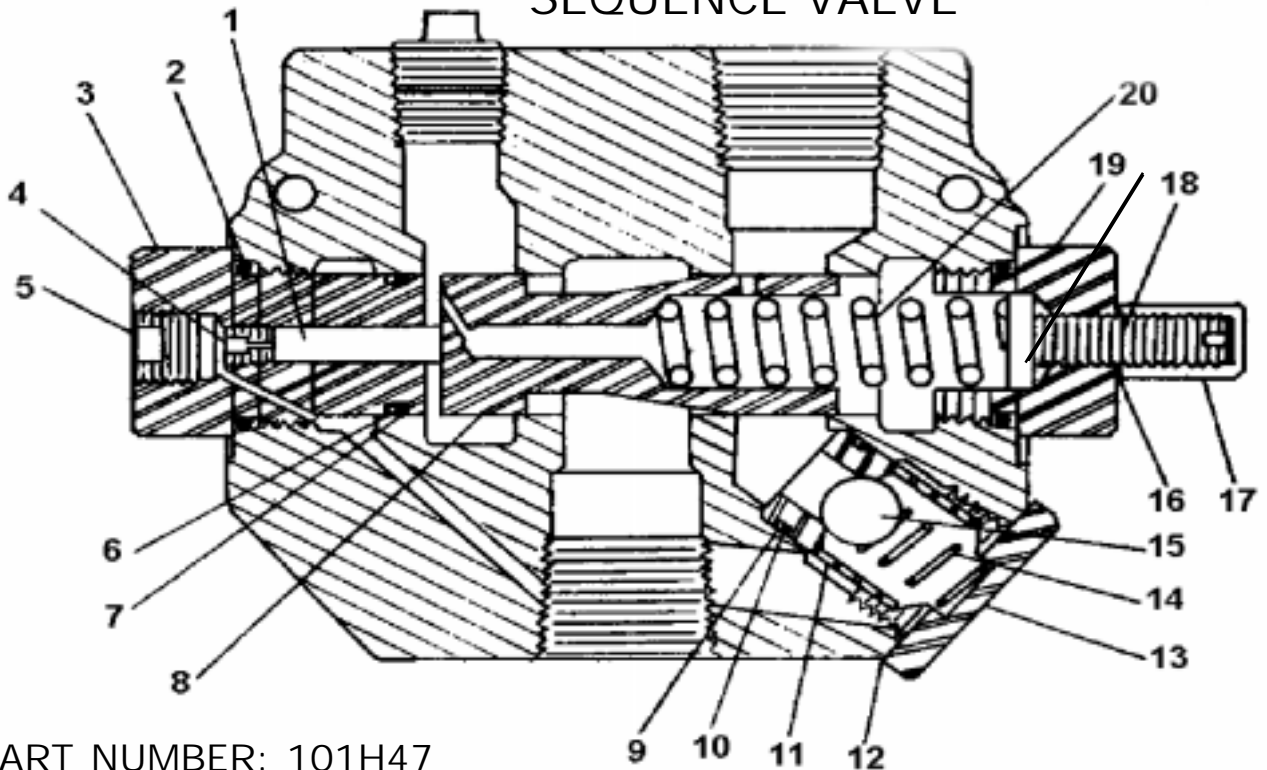

PART NUMBER: 101H47

KEY NO.	PART NO.	DESCRIPTION
1	A101H49	Piston
2	A101H50	O-ring
3	A101H51	External pilot plug
4	A101H52	Orifice
5	A101H53	Plug
6	A101H54	O-ring
7	A101H55	Backup washer
*8	A101H70	Metering spool
9	A101H57	Backup washer
10	A101H58	O-ring
11	A101H59	Check seat
12	A101H60	Aluminum washer
13	A101H61	Check plug
14	A101H62	Check spring
15	A101H63	Check ball
16	A101H64	Aluminum washer
17	A101H65	Acorn nut
18	A101H66	Adjusting screw
19	A101H69	Adjusting plug - RD1075 SM
20	A101H68	Metering spring
21		O-ring
*	A101H71	Valve body

* NOT SOLD SEPARATELY

SETTING THE SEQUENCE VALVE AND COUNTERBALANCE VALVE RELATIONSHIP

The sequence valve controls two hydraulic circuits with one hydraulic remote. Ashland Industries incorporates a sequence valve to control the Apron and Pushoff cylinder systems. When the tractors hydraulic remote is activated, oil flows first to the apron cylinders until they are fully extended. Once the cylinders are fully extended, the apron circuits' hydraulic pressure begins to increase. Once the pressure threshold is surpassed (which is adjustable. See adjustment section), the sequence valve diverts the oil flow to the pushoff's hydraulic circuit. Once the pushoff is completely extended the operator then reverses the tractors hydraulic remote. The counterbalance valve will hold the apron open until the pushoff is fully retracted. The counterbalance valve then opens and allows the apron to close.

INSTRUCTIONS for establishing a good sequence valve and counterbalance valve relationship:

STEP 1 SEQUENCE VALVE

Remove acorn nut from end of sequence valve with a 1/2" wrench and loosen jam nut. Turn adjustment screw, using a 4mm hex wrench, clockwise until front apron rises before the push-off begins to advance while the earthmover is empty. Turn the adjustment screw an additional 1/4 turn clockwise, tighten jam nut, then replace the acorn nut and tighten. Torque check valve assembly and internal pilot plug to 25 ft.-lbs. maximum.

STEP 2 COUNTERBALANCE VALVE

Remove acorn nut from end of Counterbalance valve and loosen jam nut. Turn adjustment screw clockwise until front apron holds in a raised position while rear gate is being retracted. Turn the adjustment screw an additional 1/4 turn clockwise, tighten jam nut, then replace the acorn nut and tighten. DO NOT tighten adjusting screw more than necessary.

NOTE:

Sequence valve identified by "S" imprint on No. 19 adjusting plug per previous page.

Counterbalance valve identified by "CB" imprint on No. 19 adjusting plug per previous page.

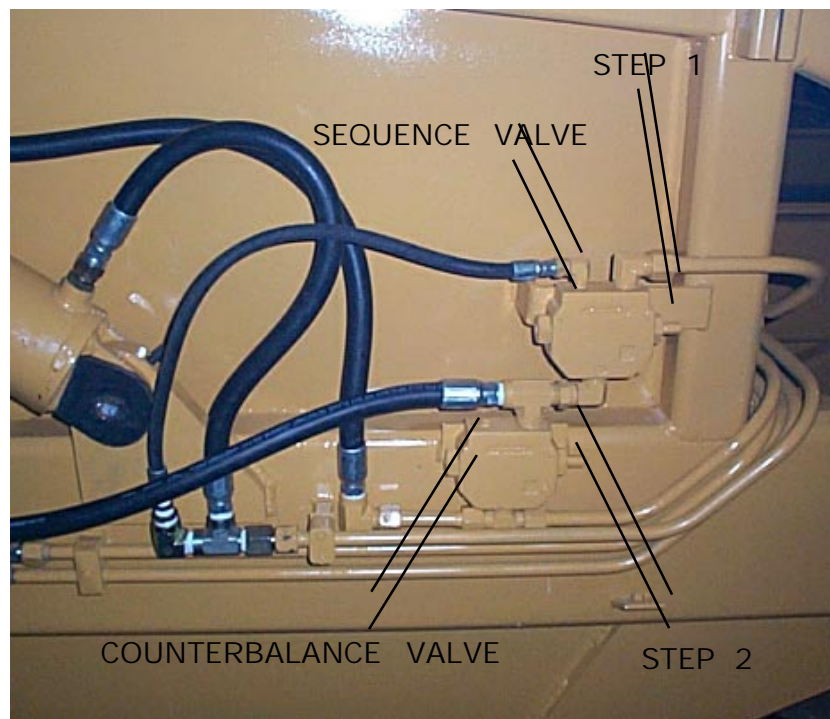

MAINTENANCE CHECKLIST

1. Grease all zerks.
 - a) Every 8 hours of operation.
 - b) See Lubrication Points section on next page.

2. Greasing the hubs.
 - a) Re-pack wheel bearings after 600 hrs of operation.
 - b) Completely clean grease out of hub and bearings every 1200 hours of operation.

3. Check tire pressure.
 - a) 20.5 - 25, 12-ply tire requires a tire pressure of 35-40 psi on a rear machine, 40-50 on a front machine.

4. Check all pins for signs of wear.
 - a) Daily

5. Check wheel lug nut torque.
 - a) After first 2 hours of operation.
 - b) Recheck daily for next 2 weeks.
 - c) Tighten wheel lug nuts in a star pattern.
 - d) Torque wheel lug nuts to 450 ft-lbs.

6. Check and retighten all bolts.
 - a) After initial 10 hours of use.
 - b) Again after 50 hours of use.
 - c) See Torque Specifications on next page.

7. Inspect cutting edges.
 - a) Daily
 - b) Replace cutting edges when center blade has been worn to approximately 6" and side edges worn to approximately 4".



CAUTION! Failure to replace worn cutting edges may result in unnecessary wear to the earthmover sides and floor.

Note: Please specify left or right "L" shaped cutting edges when ordering replacements.

TORQUE SPECIFICATIONS

<i>Grade 8</i>	
<i>Bolt</i>	<i>Torque</i>
<i>Diameter</i>	<i>ft-lbs</i>
1/4"	12
5/16"	25
3/8"	45
7/16"	70
1/2"	110
9/16"	150
5/8"	220
3/4"	380
7/8"	600
1"	900
1-1/8"	1280
Lug Nuts	750

LUBRICATION

1. Grease all zerks every 8 hrs of operation with high quality, general-purpose grease.
 - a) Grease until grease flows from around pin.

Lubrication Points

1. Hitch – Horizontal and vertical pins.
2. Lift Cylinders – Rod end & Trunion; Both left & right sides.
3. Front Arm Pivot Joint – Both left & right sides.
4. Apron Cylinders – Rod clevis pin; Both left & right sides.
5. Apron Pivot Pin – Both left & right sides.
6. Hold-down Rollers – Both left & right sides.
7. Floor Rollers – Both left & right sides.
8. Tapered Rollers – Both left & right sides.

HYDRAULIC SYSTEM

Standard Two-Circuit Hydraulic Plumbing

The apron cylinders and the push-off cylinder are controlled on the same circuit with the sequence of the operation controlled by a sequence valve. The other hydraulic circuit controls the lift cylinders on the earthmover.

*To adjust the sequence valve, see Troubleshooting section.

Optional Three-Circuit Hydraulic Plumbing

The apron cylinders, push-off cylinder, and lift cylinders are all on separate hydraulic circuits.

TROUBLESHOOTING

Introduction

With proper care and maintenance, the I-175XL2 will give many years of reliable service. When a situation arises where the earthmover performance is not satisfactory, this section will give some pointers on finding and correcting the problem.

Grease zerk will not take grease.

1. Grease zerk plugged.
 - a) Remove and replace grease zerk.
2. Pin is frozen.
 - a) Remove, clean, and inspect pin.
 - b) Replace pin if necessary.
3. Bushing grease passage is not aligned with grease zerk.
 - a) Remove, clean, inspect, and realign bushing.
 - b) Replace bushing if necessary and realign.

Push-off rollers do not roll.

1. The rollers need lubrication.
 - a) Check zerk hole and grease.
 - b) Remove pin, clean, inspect, and replace if necessary.
2. The roller bushing is worn out.
 - a) Remove roller assembly and replace bushing.
 - b) See parts manual.

Cylinders will not hold in preset position, i.e. the cylinder creeps.

1. Seals leaking internally.
 - a) Remove and replace seal kit.

Machine cuts unevenly.

1. Cutting edges worn unevenly.
 - a) Replace cutting edges.
2. Improperly inflated tires.
 - a) Check air pressure in tires.

Apron closes slowly

or

Apron and push-off are not working well together.

1. Sequence valve needs adjusting.
 - a) Remove acorn nut from end of sequence valve with a ½" wrench. Turn adjustment screw, using a 4mm hex wrench, clockwise until front apron rises before the push-off advances while the earthmover is empty. Turn the adjustment screw an additional ¼ turn clockwise, then replace the acorn nut and tighten.
 - b) Torque check valve assembly and int. pilot plug to 25 ft-lbs maximum.



CAUTION! Overtightening check valve assembly and int. pilot plug will cause internal damage to the sequence valve.

Note: Check valve assembly may leak slightly when torqued to 25 ft-lbs.

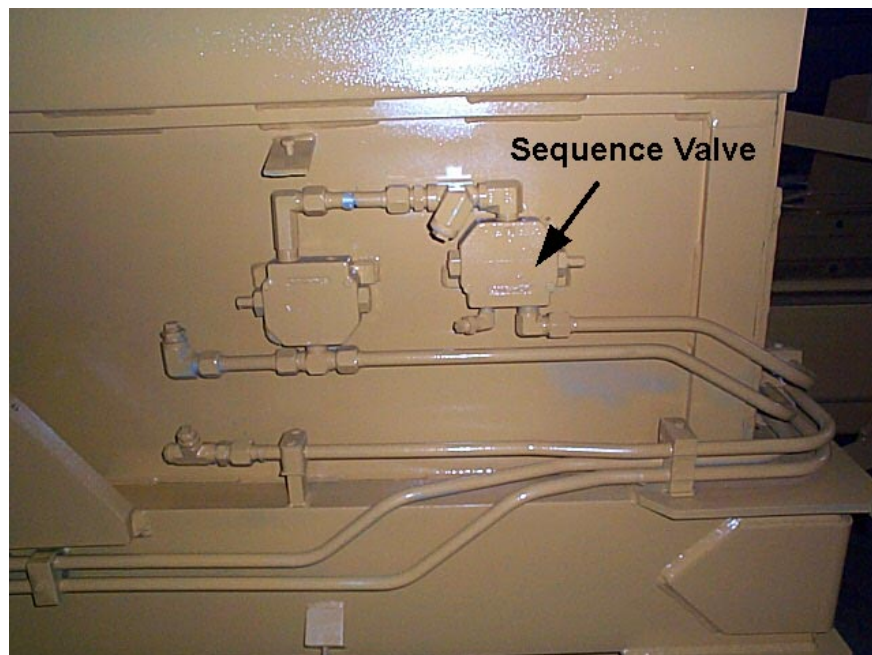

Limited Warranty Statement

Ashland Industries Inc. warrants each new product to be free from defects in material and workmanship. This warranty is applicable only for the normal service life expectancy of the product or components, not to exceed six consecutive months from the date of delivery of the new Ashland Industries product to the original purchaser, or the date the product is first put into service via a rental agreement or other means, whichever occurs first.

Genuine Ashland Industries Inc. replacement parts and components will be warranted for 30 days from date of purchase, or the remainder of the original equipment warranty period, whichever is longer.

Under no circumstances will it cover any merchandise or components thereof, which in the opinion of the company, has been subjected to misuse, unauthorized modification, alterations, an accident or if repairs have been made with parts other than those obtained through Ashland Industries Inc.

Ashland Industries Inc. in no way warrants Tires since these items are warranted separately by their respective manufacturer. Please call Ashland Industries Inc. to receive phone numbers of tire suppliers.

Ashland Industries Inc. in no way warrants wearable items such as cutting edges, front dolly wheel balls, socket halves.

Our obligation under this warranty shall be limited to repairing or replacing, free of charge to the original purchaser, any part that, in our judgement, shall show evidence of such defect, provided further that such part shall be returned within 30 days from the date of failure to Ashland Industries Inc. routed through the dealer and distributor from whom the purchase was made, transportation charges prepaid. Upon warranty approval proper credits will be reimbursed for transportation.

This warranty shall not be interpreted to render Ashland Industries Inc. liable for injury or damages of any kind or nature to person or property. This warranty does not extend to the loss revenue, extra labor cost associated with downtime, substitute machinery, rental or for any other reason.

Except as set forth above, Ashland Industries Inc. shall have no obligation or liability of any kind on account of any of its equipment and shall not be liable for special or consequential damages. Ashland Industries Inc. make no other warranty, expressed or implied, and, specifically, Ashland Industries Inc. disclaims any implied warrant or merchantability or fitness for a particular purpose. Some states or provinces do not permit limitations or exclusions of implied warranties or incidental or consequential damages, so the limitations or exclusion in this warranty may not apply.

This warranty is subject to any existing conditions of supply which may direct affect our ability to obtain materials or manufacture replacement parts.

Ashland Industries Inc. reserves the right to make improvements in design or changes in specifications at any time, without incurring any obligation to owners of units previously sold

No one is authorized to alter, modify or enlarge this warranty nor the exclusion, limitations and reservations.

Ashland Industries Inc.
Warranty Department