

Ashland **INDUSTRIES, INC.™**



I-155XL PARTS MANUAL

Version 3-03

Ashland Industries Inc.
1115 Rail Drive
P.O. Box 717
Ashland, WI. 54806
Ph: 877-634-4622 *Toll Free*
Ph: 715-682-4622
Fx: 715-682-9717
www.ashlandind.com





HOW TO ORDER PARTS:

IMPORTANT

Parts must be ordered through your local authorized ASHLAND dealer.

Be sure to state MODEL and SERIAL NUMBER of your machine, PART NUMBER, DESCRIPTION and QUANTITY needed.

Unless this is done, we cannot provide prompt service or assure shipment of the correct parts.



Ashland Industries weldable replacement parts are available to rebuild, modify or update your scraper to current factory specifications.

INDEX

Page 3.	Operators and Maintenance Instructions
Page 4.	Safety Guidelines
Page 5.	Illustration - Assembly
Page 6.	Illustration - Gooseneck Frame Assembly
Page 7.	Illustration - Apron Assembly
Page 8.	Illustration - Bowl and Frame Assembly
Page 9.	Parts List - Bowl and Frame
Page 10.	Illustration and Parts List - Push Off Gate Assembly
Page 11.	Illustration and Parts List - Pole and Axle Assembly
Page 12.	Illustration and Parts List - Front Wheel and Hub Assembly
Page 13.	Illustration and Parts List - Rear Wheel and Hub Ass'y. - Std.
Page 14.	Illustration and Parts List - Rear Wheel and Hub Ass'y. - Option
Page 15.	Illustration and Parts List - Hydraulic Cylinder 4" x 13"
Page 16.	Illustration and Parts List - Hydraulic Cylinder 5" x 20"
Page 17.	Illustration - Hydraulic Cylinder 4-1/2" x 60"
Page 18.	Parts List - Hydraulic Cylinder 4-1/2" x 60"
Page 19.	Illustration and Parts List - Sequence Valve
Page 20.	Adjustment - Sequence Valve
Page 21.	Warranty Statement

OPERATORS AND MAINTENANCE INSTRUCTIONS

This scraper is a durable piece of equipment and with proper care will yield many years of trouble free operation. The scraper requires a power source with TWO 4 way (double acting) hydraulic control valves.

The scraper should be greased at all points where grease fittings are provided. Connect hydraulic hoses to the tractor and retract lift cylinders to REMOVE TRANSPORT LOCK PINS (point A), then extend and retract all cylinders several times to force out any air from the hydraulic cylinders and lines. Check the oil levels in the tractor hydraulic system and add to maintain the proper level. Care should be used when adding oil or when disconnecting any oil line to keep all dirt out of the oil as dirt is a major factor in the failure of hydraulic components.

When the scraper is placed into operation, the operator will have to "feel out" the amount of depth of cut to obtain maximum loading efficiency. This is usually accomplished by taking a lesser and more uniform cut; however, some soil conditions such as loose sand may require a "pumping action" obtained by taking successive deep cuts and lifting out of cut as the tractor begins to lose power or traction.

1. After 10 hours work, all bolts should be checked and tightened if necessary.
2. Every 10 hours all grease fittings should be lubricated.
3. After 50 hours work, all bolts should be rechecked and tightened if necessary. Check wheel bearings and adjust if necessary.
4. After 300 hours work, clean and repack wheel bearings and replace, if necessary, cutting edges, worn pins, etc.



SAFETY SIGNAL WORDS

Note the use of the signal words DANGER, WARNING and CAUTION with the safety messages. The appropriate signal word for each has been selected using the following guidelines:

DANGER: Indicates an imminently hazardous situation that, if not avoided, will result in death or serious injury. This signal word is to be limited to the most extreme situations typically for machine components which, for functional purposes, cannot be guarded.



WARNING: Indicates a potentially hazardous situation that, if not avoided, could result in death or serious injury, and includes hazards that are exposed when guards are removed. It may also be used to alert against unsafe practices.



CAUTION: Indicates a potentially hazardous situation that, if not avoided, may result in minor or moderate injury. It may also be used to alert against unsafe practices.



GENERAL SAFETY GUIDELINES

Safety of the operator is one of the main concerns in designing and developing a new piece of equipment. Designers and manufacturers build in as many safety features as possible. However, every year many accidents occur which could have been avoided by a few seconds of thought and a more careful approach to handling equipment. You, the operator, can avoid many accidents by observing the following precautions in this section. To avoid personal injury, study the following precautions and insist those working with you, or for you, follow them.

Replace any CAUTION, WARNING, DANGER or instruction safety decal that is not readable or is missing. Location of such decals is indicated in this booklet.

Do not attempt to operate this equipment under the influence of drugs or alcohol.

Review the safety instructions with all users annually.

This equipment is dangerous to children and persons unfamiliar with its operation. The operator should be a responsible adult familiar with farm machinery and trained in this equipment's operations. Do not allow persons to operate or assemble this unit until they have read this manual and have developed a thorough understanding of the safety precautions and of how it works.

To prevent injury or death, use a tractor equipped with a Roll Over Protective System (ROPS). Do not paint over, remove or deface any safety signs or warning decals on your equipment. Observe all safety signs and practice the instructions on them.

Never exceed the limits of a piece of machinery. If its ability to do a job, or to do so safely, is in question - DON'T TRY IT.

ILLUSTRATION * ASSEMBLY

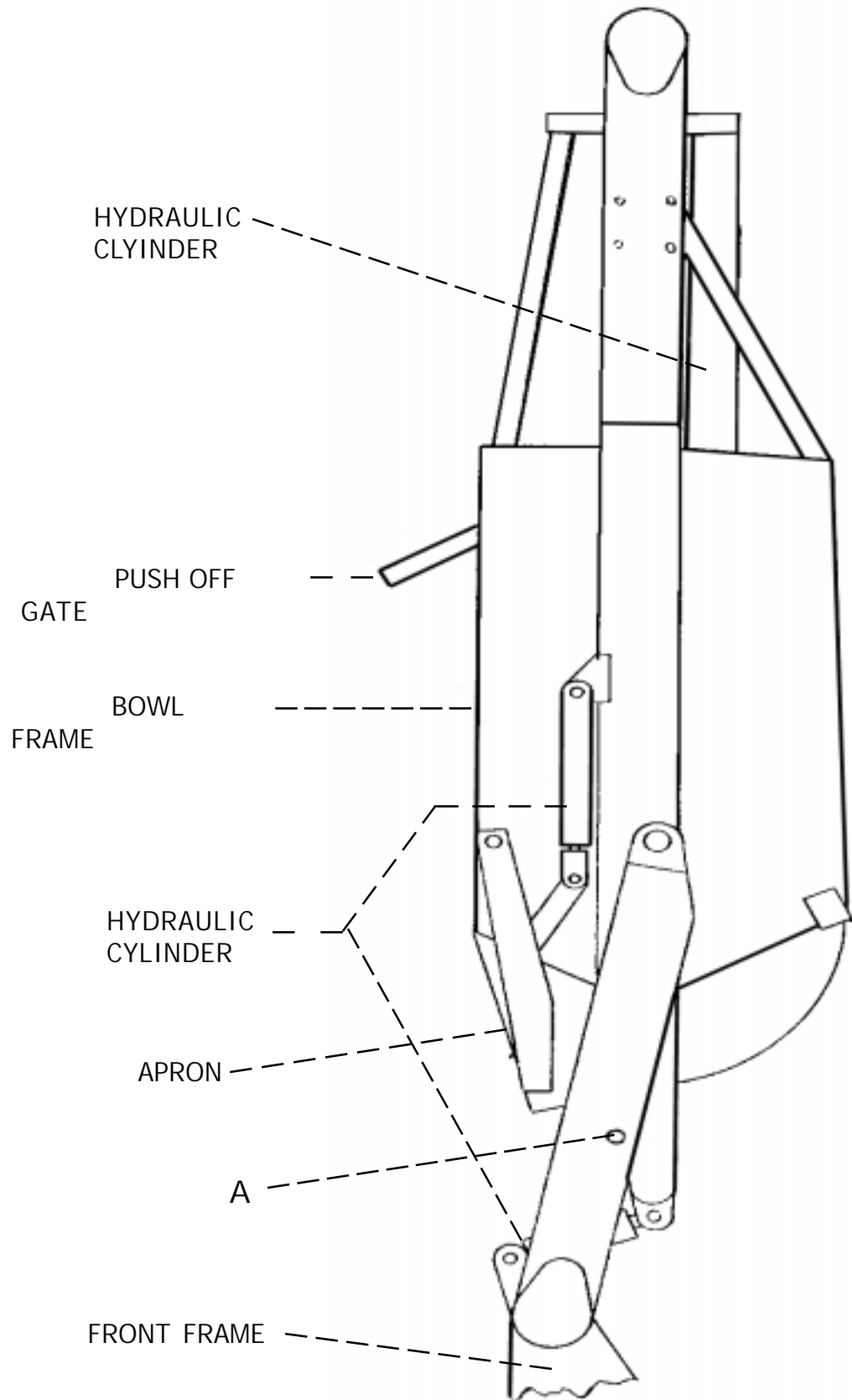

GOOSENECK FRAME ASSEMBLY

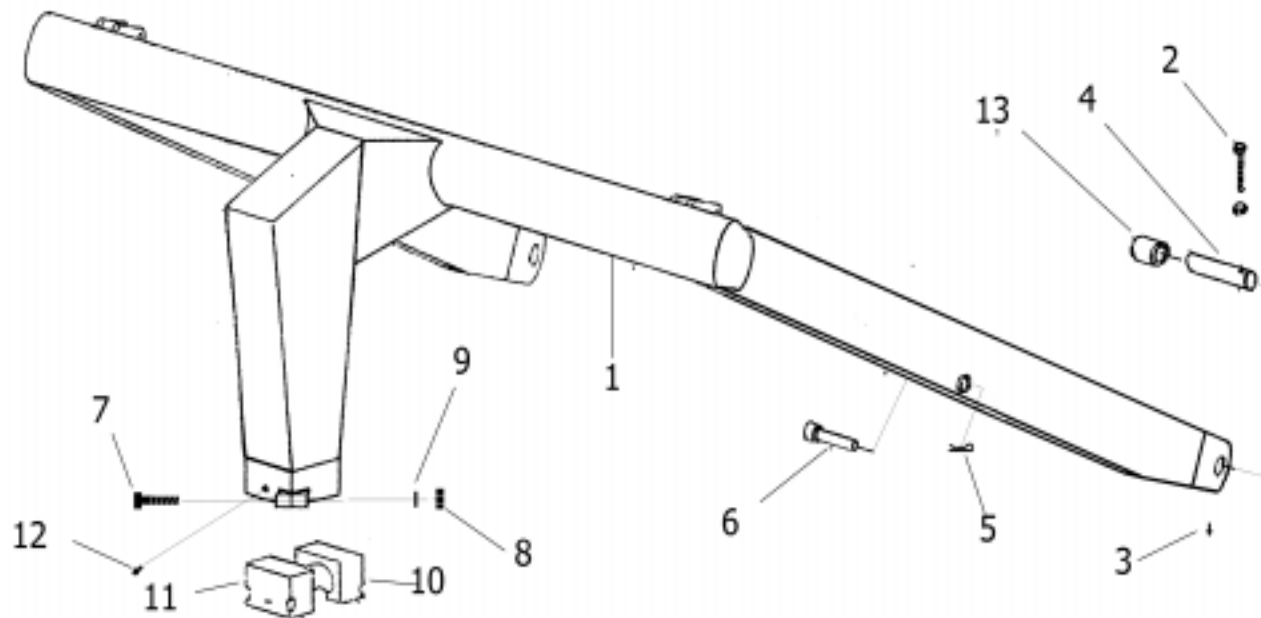

PARTS LIST GOOSENECK FRAME ASSEMBLY MODEL I-155 XL

KEY NO.	PART NO.	DESCRIPTION
1.	A14001B	Gooseneck Frame
2.	AFB-00054	Bolt, 1/2" NC x 3-1/2" Lg.
3.	14505	Grease Zerk - Straight
4.	A10152A	Pin, Frame Attachment, 2" OD x 8-1/16" Long
5.	-----	Hair Pin
6.	A10153	Pin, Transport Lock
7.	AFB-00025	Bolt, 7/8"NC x 5" Lg. Grade 8
8.	AFN-00019	Nut, 7/8"NC
9.	8125	Lockwasher 7/8"
10.	A14002	Cast Socket Half - Rear
11.	A14003	Cast Socket Half - Front w/Zerk Hole
12.	A2206	Grease Zerk - Long Shank
13.	A14039	Bushing, 2-3/8" OD x 2" Long

MODEL I-155 XL
APRON ASSEMBLY

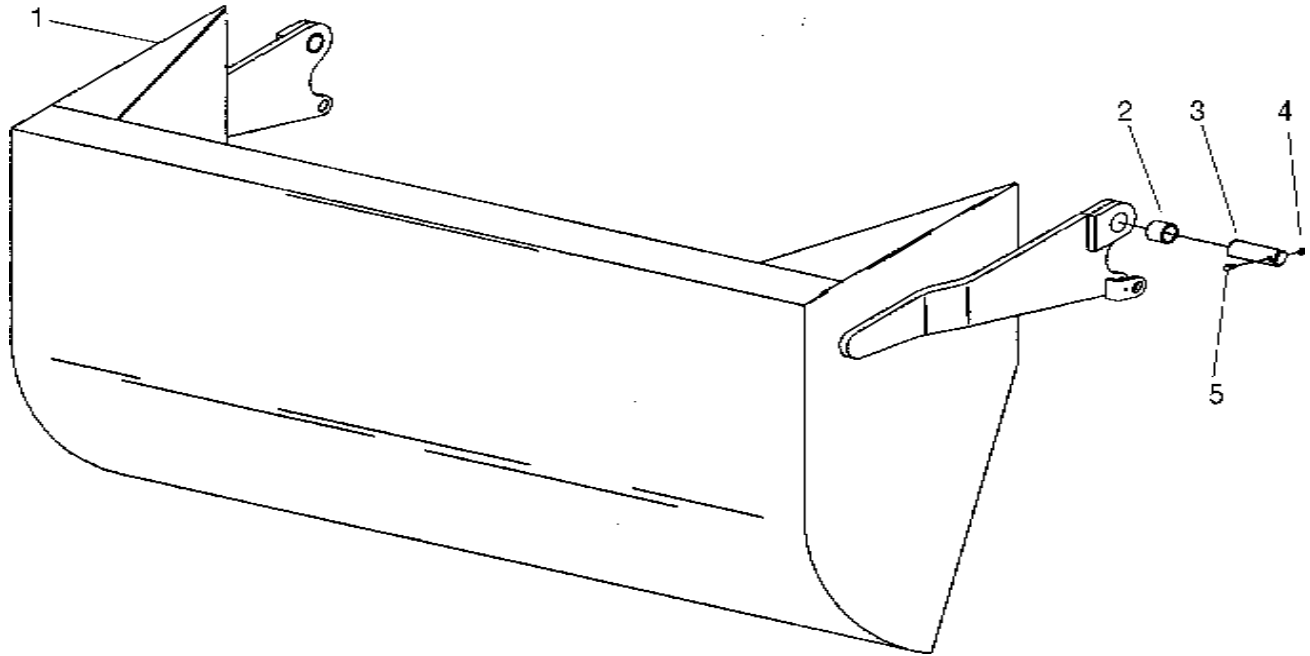

KEY NO.	PART NO.	DESCRIPTION
1.	A123310	Apron Model I-150 TS
2.	A16027	Bushing: 2" OD x 1-1/2" ID x 2" Long
3.	A123337	Pin: 1-1/2" x 5-3/8"
4.	7450	Nut: 3/8" NC
5.	AFB-00049	Bolt: 3/8" NC x 3"

BOWL and FRAME ASSEMBLY

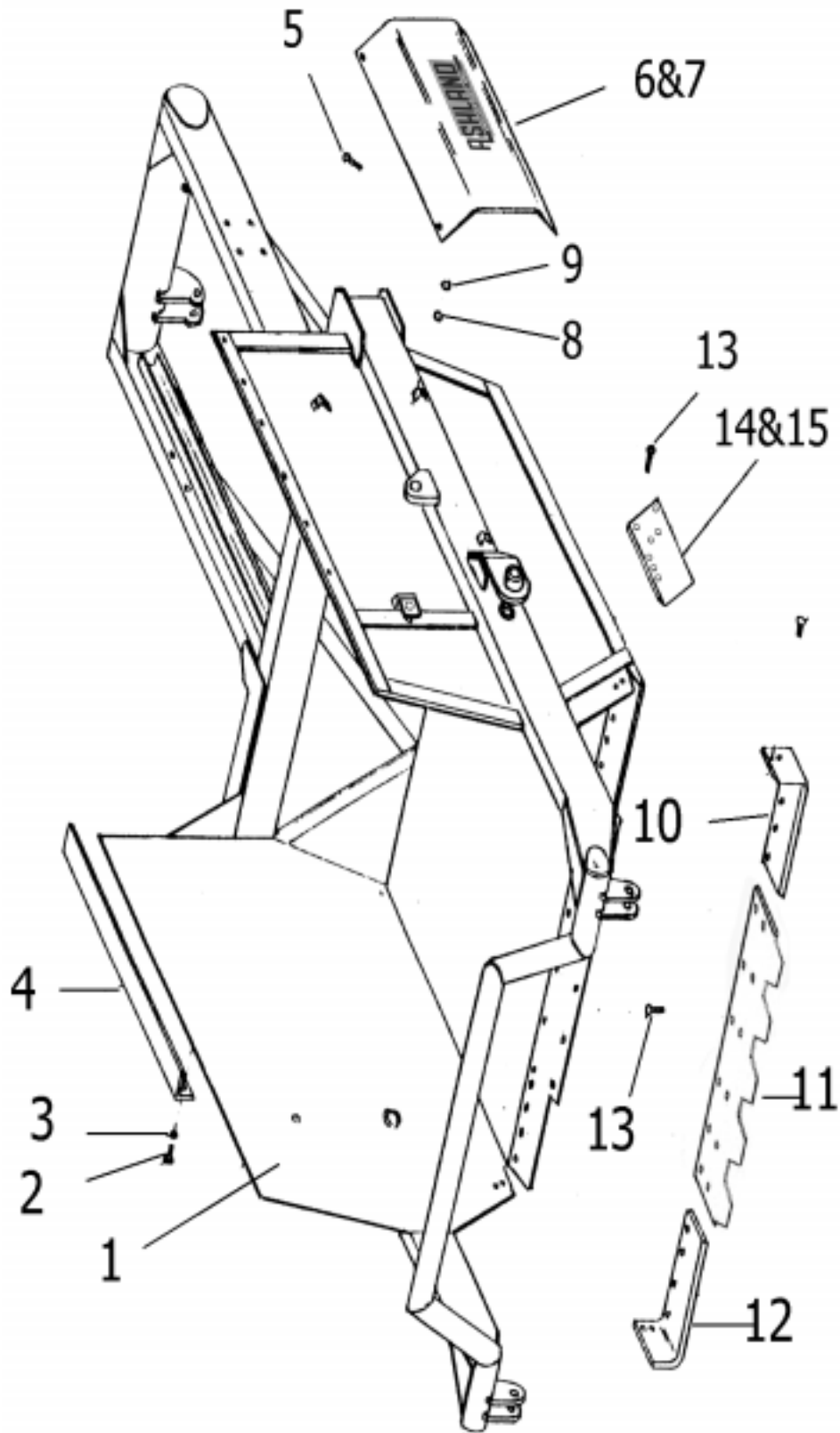

PARTS LIST
BOWL AND FRAME ASSEMBLY
MODEL I-155 XL SCRAPER

KEY NO.	PART NO.	DESCRIPTION
1.		Bowl and Frame, Model I-155 XL - w/Standard rear Tires Bowl and Frame, Model I-155 XL - w/29.5 X 25 rear Tires
2.	7115	Capscrew 5/8"NC x 1-1/4" Lg.
3.	8110	Lockwasher 5/8"
4.	A17504	Gate Containment Angle
5.	AFB-00034	Bolt 3/8"NC x 1" Lg.
6.	A10157	Cylinder Guard - Left Hand
7.	A10158	Cylinder Guard - Right Hand
8.	7450	Nut 3/8" NC
9.	8078	Lockwasher 3/8"
10.	A123332L PB9P-NC-088-0275 AFN-00019	Left Cutting Edge Plow Bolt: 7/8 NC X 2-3/4" -> 6 Required Nut: 7/8" NC -> 6 Required
11.	A123330SER	Center Cutting Edge, Serrated
13.	PB9P-NC-088-0275 AFN-00019	Plow Bolt: 7/8 NC X 2-3/4" -> 12 Required Nut: 7/8" NC -> 12 Required
12.	A123332R PB9P-NC-088-0275 AFN-00019	Right Cutting Edge Plow Bolt: 7/8 NC X 2-3/4" -> 6 Required Nut: 7/8" NC -> 6 Required
14.	A123338L PB9P-NC-088-0275 PB9P-NC-088-0225 AFN-00019 AFN-00026	(Optional) Left Shaver Bit Plow Bolt: 7/8 NC X 2-3/4" -> 5 Required Plow Bolt: 7/8 NC X 2-1/4" -> 2 Required Nut: 7/8" NC -> 5 Required Nut: 7/8" NC Jam -> 2 Required
15.	A123338R PB9P-NC-088-0275 PB9P-NC-088-0225 AFN-00019 AFN-00026	(Optional) Right Shaver Bit Plow Bolt: 7/8 NC X 2-3/4" -> 5 Required Plow Bolt: 7/8 NC X 2-1/4" -> 2 Required Nut: 7/8" NC -> 5 Required Nut: 7/8" NC Jam-> 2 Required

PUSHOFF GATE ASSEMBLY I-155 XL

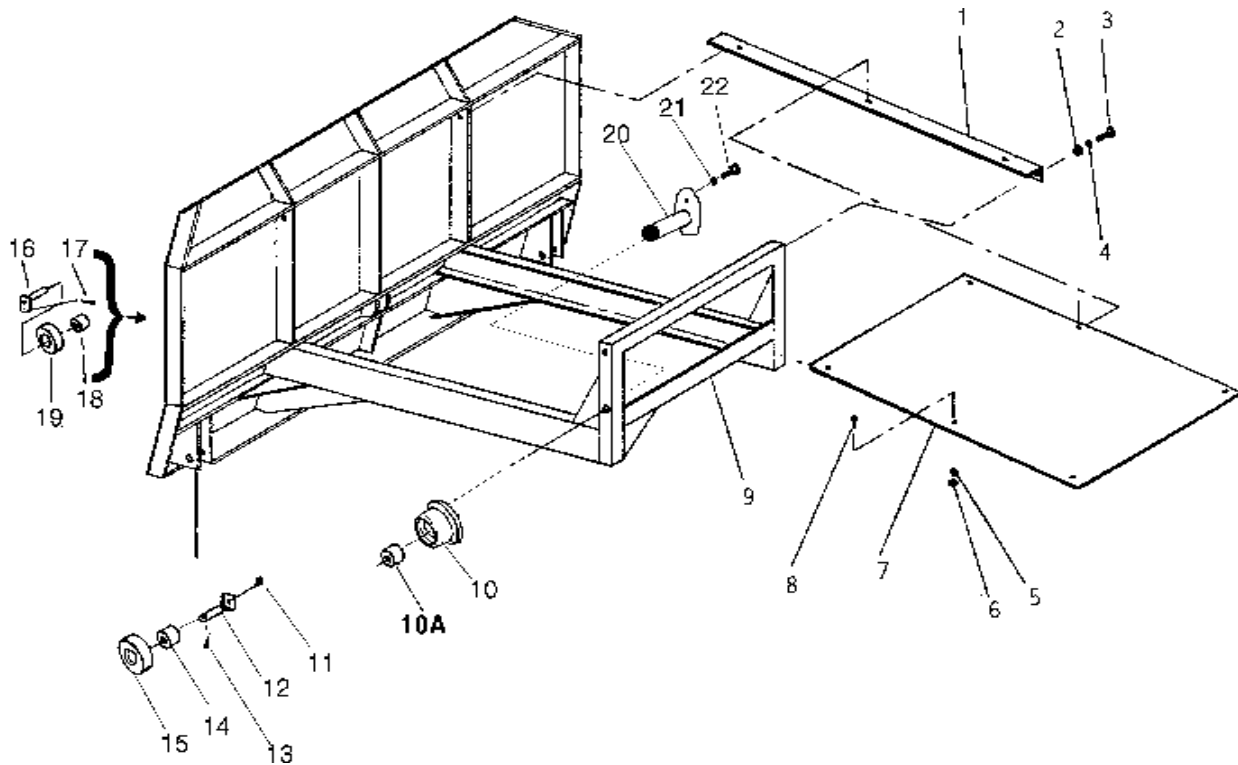

KEY NO.	PART NO.	DESCRIPTION
1.	A14022	Brace
2.	AFN-00006	Nut: 3/4" NC
3.	AFB-00037	Bolt: 3/4" NC x 2" Lg.
4.	AFW-00002	Lockwasher: 3/4"
5.	8078	Lockwasher: 3/8"
6.	7450	Nut: 3/8" NC
7.	A14023	Dirt Shield
8.	AFB-00034	Bolt: 3/8 NC x 1" Lg.
9.	A14024	Pushoff Gate: Model I-150
10.	A123306	Roller: Rear Gate
10A.	A123307	Bushing
11.	AHF-00028	Grease Fitting: 1/8" NPT -90 degree
12.	A6007A	Pin: 1-1/4" x 4-1/8" Lg.
13.	AFP-00001	Cotter Pin: 1/4 X 3-1/2"
14.	A10163	Bushing: 1-3/4" OD x 1-1/4" ID
15.	A10164	Roller: 3-1/2 OD X 1-3/4 ID
16.	A123288	Pin: 1-1/4 X 3-1/4" Tab Head
17.	7036	Bolt: 1/2 NC X 2"
18.	A10163	Bushing: 1-3/4" OD x 1-1/4" ID
19.	A10164	Roller: 3-1/2 OD X 1-3/4 ID
20.	A123305	Pin: 1-1/4 X 2-3/4"
21.	8100	Lockwasher: 1/2"
22.	AFB-00033	Bolt: 1/2 NC X 2-1/2"

POLE and AXLE ASSEMBLY

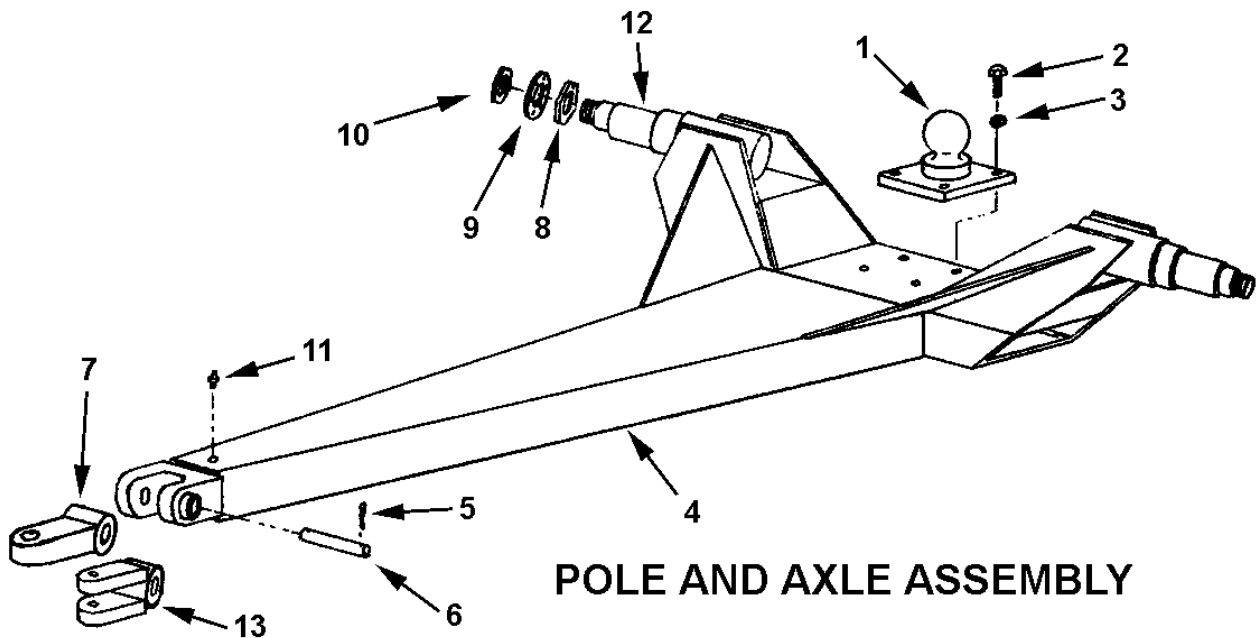

PARTS LIST POLE and AXLE ASSEMBLY MODEL I-155 XL

KEY NO.	PART NO.	DESCRIPTION
1.	A14017	Ball Swivel
2.	AFB-00018	Bolt 1" NC x 3" Long
3.	AFW-00006	Lockwasher 1"
4.	A14018	Pole
5.	-----	Cotter Pin 5/16" x 3" Long
6.	A14019	Pin 1-3/4" x 7-3/8" Long
7.	A14020A	Swivel Hitch Single Lip
8.	A10172	Nut with Lock Pin
9.	A10049A	Lock Collar
10.	A10048	Spindle Nut
11.	14505	Grease Fitting
12.	A14021	Spindle (weld on)
13.	A14020	Swivel Hitch, Double Lip (optional)

FRONT WHEEL and HUB ASSEMBLY

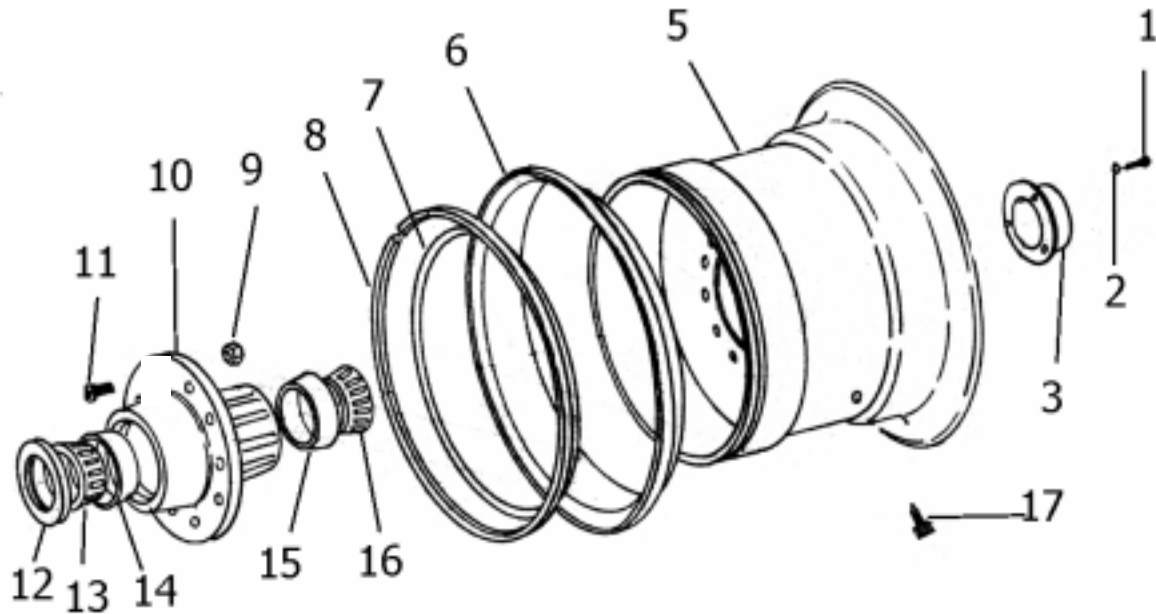

PARTS LIST FRONT WHEEL and HUB ASSEMBLY MODEL I-155 XL

KEY NO.	PART NO.	DESCRIPTION
1.	AFB-00020	Bolt 5/16" NC x 3/4" Lg.
2.	8070	Lockwasher 5/16"
3.	A14004	Hub Cap
5.	A14006A	Wheel 14" x 25"
6.	A14007A	Side Ring for 14" x 25" Wheel
7.	A14008	"O" Ring
8.	A14009	Lock Ring
9.	A10046	Lug Nut
10.	A14010	Hub
11.	A10176	Stud
12.	A14011	Grease Seal (CR 42624)
13.	A14012	Bearing Cone (Timken 749)
14.	A14013	Bearing Cup (Timken 742)
15.	A14014	Bearing Cup (Timken 632)
16.	A14015	Bearing Cone (Timken 644)
17.	A14016	Valve Stem

PARTS LIST
 REAR WHEEL and HUB ASSEMBLY - STANDARD
 MODEL I-155XL

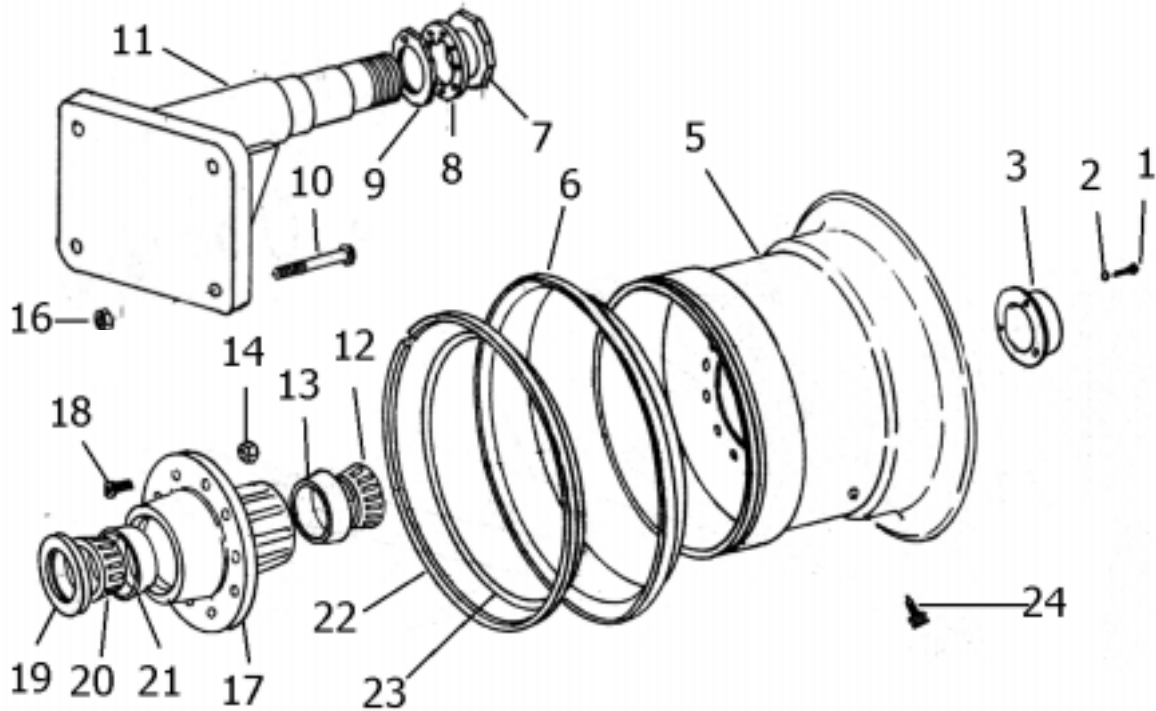

KEY NO.	PART NO.	DESCRIPTION
1.	AFB-00020	Bolt 5/16" NC x 3/4" Lg.
2.	8070	Lockwasher 5/16"
3.	A14004	Hub Cap
5.	A14035	Wheel 17" x 25"
6.	A14036	Side Ring
7.	A10048	Spindle Nut
8.	A10049A	Lock Collar
9.	A10172	Nut with Lock Pin
10.	AFB-00024	Bolt 1" NF x 7" Lg.
11.	A14037	Spindle
12.	A14015	Bearing Cone (Timken 644)
13.	A14014	Bearing Cup (Timken 632)
14.	A10046	Lug Nut
16.	AFN-00001	Nut 1" NF Toplock
17.	A14010	Hub
18.	A10176	Stud
19.	A14011	Grease Seal (CR 42624)
20.	A14012	Bearing Cone (Timken 749)
21.	A14013	Bearing Cup (Timken 742)
22.	A14038	Lock Ring
23.	A14008	"O" Ring
24.	A14016	Valve Stem

PARTS LIST
 REAR WHEEL and HUB ASSEMBLY - w/ 29.5 X 25 TIRE OPTION
 MODEL I-160 XL

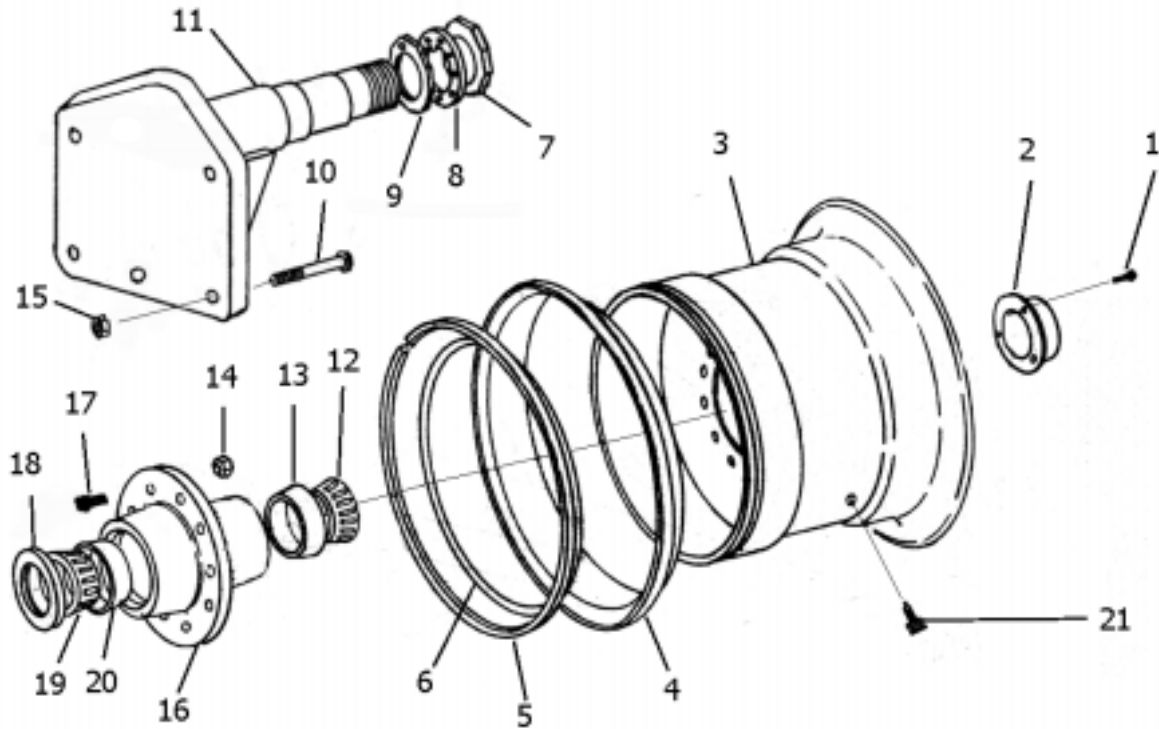

KEY NO.	PART NO.	DESCRIPTION
1.	AFB-00020	Bolt 5/16" NC X 3/4" Lg.
2.	A14004	Hub Cap
3.	A12036	Wheel Ass'y. 25" x 25"
4.	A12041	Side Ring
5.	A12042	Lock Ring
6.	A12047	O-Ring
7.	A10048	Spindle Nut
8.	A10049A	Lock Collar
9.	A10172	Nut with Lock Pin
10.	AFB-00059	Bolt 1-1/4" NF X 7" Lg.
11.	A12044	Spindle
12.	A14015	Bearing Cone (Timken# 644)
13.	A14014	Bearing Cup (Timken# 632)
14.	A12051	Lug Nut
15.	AFN-00009	Lock Nut: 1-1/4" NF
16.	A12035	Hub
17.	A12050	Lug
18.	A12037	Grease Seal (National# 416039)
19.	A12038	Bearing Cup (Timken# 854)
20.	A12039	Bearing Cone (Timken#861)
21.	A14016	Valve Stem

MODEL I-155 XL
LEFT & RIGHT SIDE APRON CYLINDER 4 X 13
PART NO. A123319

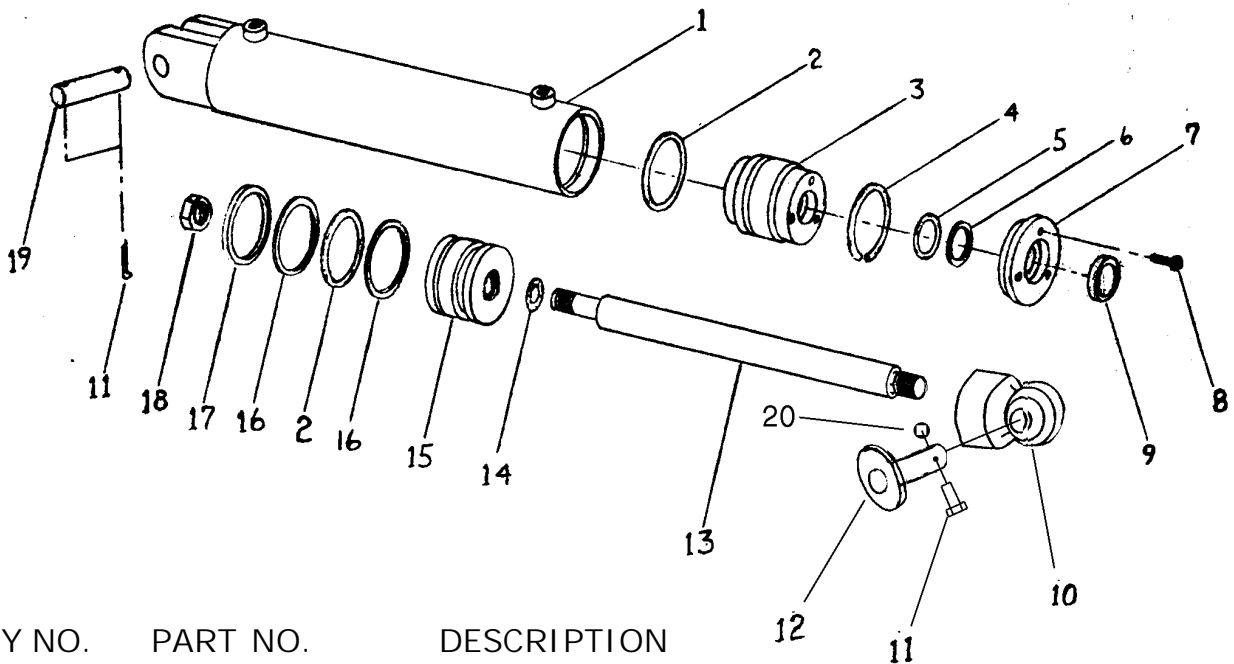

KEY NO.	PART NO.	DESCRIPTION
1.	A175H013	Cylinder Barrel
2.	A300H06	O-Ring: 4" OD x 3/16"
3.	A300H11	Head Gland
4.	A300H12	Retainer Ring
5.	A22H15	O-Ring: 1-1/2" ID x 1/8"
6.	A22H15A	Backup Washer: 1-1/2"
7.	A300H13	Gland Cap
8.	A22H18	Capscrew: 1/4" NC x 1"
9.	A22H17	Wiper Seal: 1-1/2" ID
10.		Ball Swivel End
11.	AFB-00015	HHCS: 1/2 NC X 1-1/2"
12.	A123336	Pin: Tab Head w/Grease Fitting 1 x 3-5/8"
13.	A175H02	Shaft: 1-1/2" Dia.
14.	A45H05	Piston Gasket: 1"
15.	A300H07	Piston: 4" Dia.
16.	A300H05	Backup Washer: 4" OD
17.	A300H04	Cast Iron Ring: 4" OD
18.	A300H03	Piston Nut, 1" NF
19.	A1217	Pin: 1" x 3-1/2"
20.	7500	NUT: 1/2" NC
	A300H14B	Packing Kit, Containing:
	(1) A300H04	(2) A22H15
	(2) A300H05	(1) A22H15A
	(2) A300H06	(1) A22H17
	(1) A45H05	

HYDRAULIC CYLINDER - A520H114 5" X 20" LIFT CYLINDER

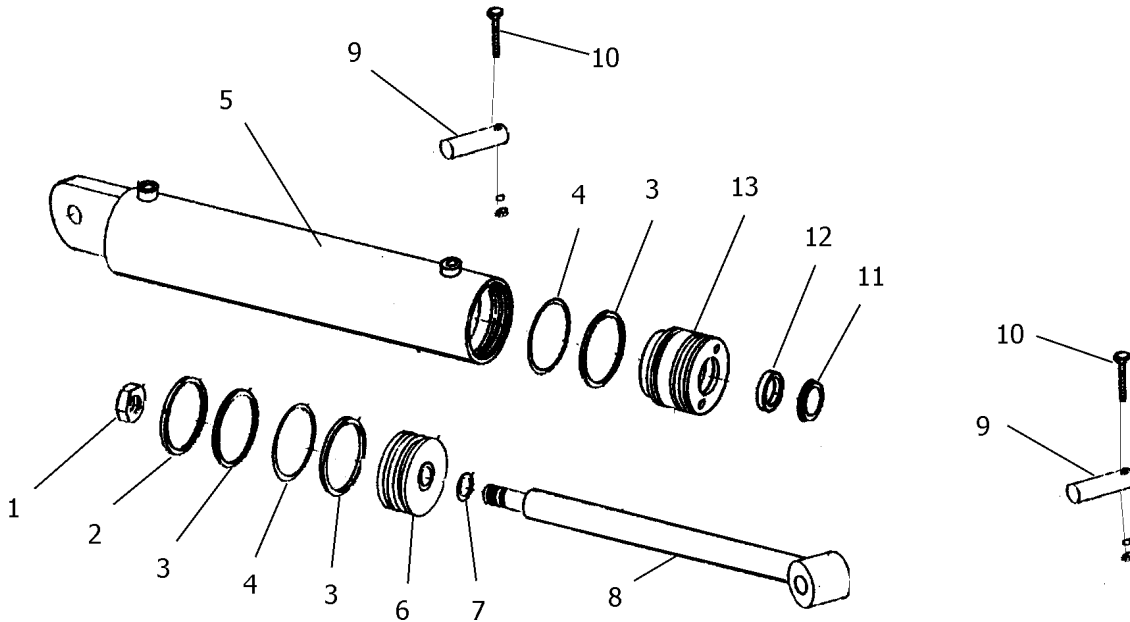

PARTS LIST LIFT CYLINDER

KEY NO.	PART NO.	DESCRIPTION
1.	A400H17	Nut 1-1/4" NF, Lock Type
2.	A400H04	Cast Ring, 5" OD
3.	A400H05	Back-up Washer, 5" OD x 1/4"
4.	A400H06	"O" Ring, 5" OD x 1/4"
5.	A80H02A	Barrel Assembly with 1-1/4" holes
6.	A80H01	Piston, 5" OD
7.	A60H52	"O" Ring, 1-1/4" OD x 1/16"
8.	A80H08A	Shaft 2" Dia.
9.	A6007A	Pin, 1-1/4" x 4-1/8" with Square Head & Grease Hole
10.	-----	Bolt 1/4" NC x 2" Lg. with Nut & Lockwasher
11.	A80H06	Wiper Seal 2" ID
12.	A80H04	Seal 2" ID
13.	A80H05A	Head Gland
	A80H07	Packing Kit, Containing:
	(1) A400H04	(1) A60H52
	(3) A400H05	(1) A80H04
	(2) A400H06	(1) A80H06

HYDRAULIC CYLINDER - A4560H114, 4-1/2" X 60"
PUSH OFF CYLINDER

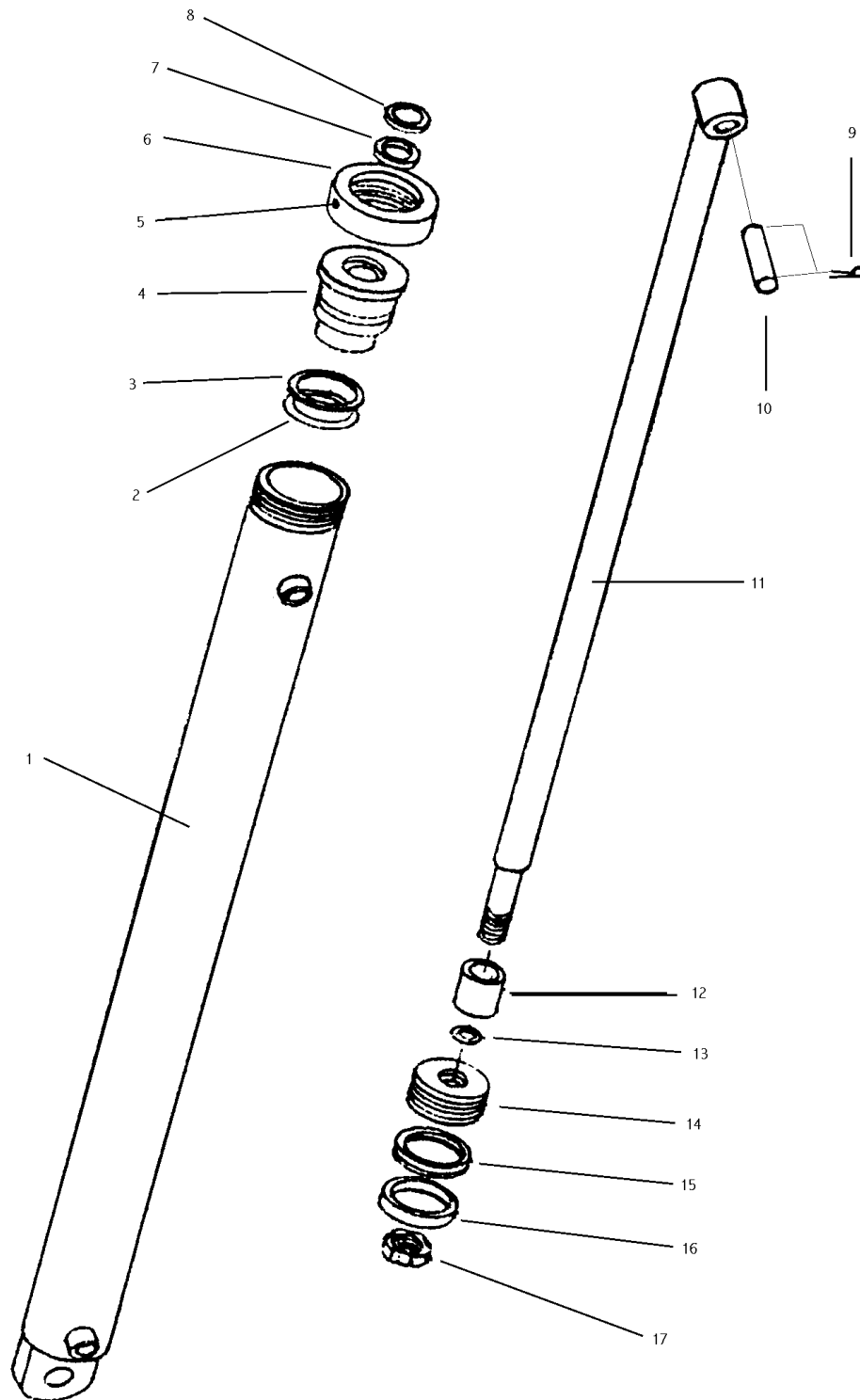

PARTS LIST
 PUSH OFF CYLINDER, A4560H114, 4-1/2" x 60"

KEY NO.	PART NO.	DESCRIPTION
1.	A175H08	Barrel Assembly, 4-1/2" Bore
2.	A175H03	"O" Ring, 4-1/2" OD x 4-1/8" ID
3.	A175H04	Back Up Washer, 4-1/2" OD x 4-1/8" ID
4.	A175H09	Head Gland
5.	-----	Set Screw, 3/8" NC
6.	A175H10	Collar
7.	A140H07	Shaft Seal, 2-1/2" ID, OU-Cup
8.	A140H08	Wiper Seal
9.	-----	Cotter Pin, 3/16" x 2"
10.	A10038	Pin, 1-1/4" Dia. x 4-1/4" Lg.
11.	A175H11	Shaft, 2-1/2" Dia.
12.	A175H06	Spacer
13.	A22H15	"O" Ring, 1-1/2" x 1-3/4" OD
14.	A175H12	Piston
15.	A175H05	Piston Seal, 4-1/2" OD
16.	A175H07	Wear Ring, 4-1/2" OD
17.	AFN-00018	Nut, Lock Type, 1-1/2" NF
	A175H15	Packing Kit, Containing:
		(1) A175H03 (1) A175H04
		(1) A140H07 (1) A140H08
		(1) A22H15 (1) A175H05
		(1) A175H07

SEQUENCE VALVE

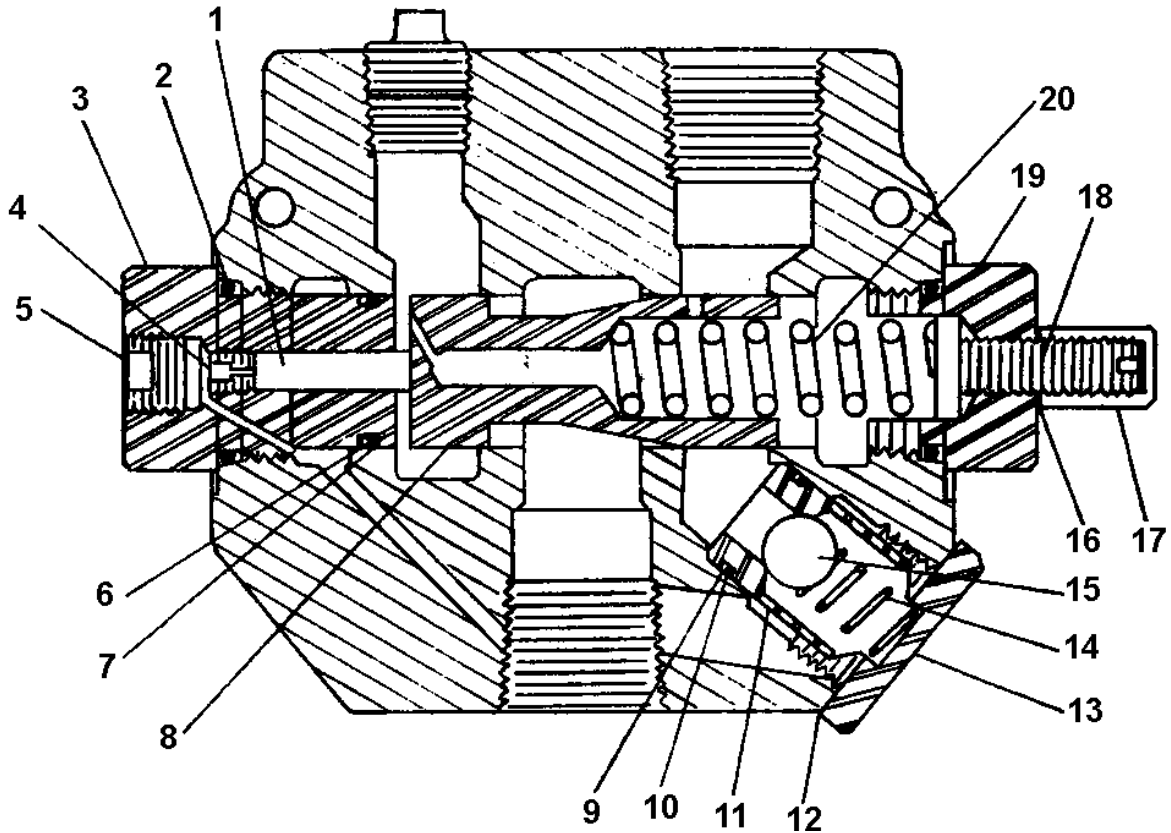

KEY NO.	PART NO.	DESCRIPTION
1	A101H49	Piston
2	A101H50	O-ring
3	A101H51	External pilot plug
4	A101H52	Orifice
5	A101H53	Plug
6	A101H54	O-ring
7	A101H55	Backup washer
*8	A101H70	Metering spool
9	A101H57	Backup washer
10	A101H58	O-ring
11	A101H59	Check seat
12	A101H60	Aluminum washer
13	A101H61	Check plug
14	A101H62	Check spring
15	A101H63	Check ball
16	A101H64	Aluminum washer
17	A101H65	Acorn nut
18	A101H66	Adjusting screw
19	A101H69	Adjusting plug - RD1075 SM
20	A101H68	Metering spring
*	A101H71	Valve body

* NOT SOLD SEPARATELY

SEQUENCE VALVE

The sequence valve controls two hydraulic circuits with one hydraulic remote. Ashland Industries incorporates a sequence valve to control the Apron and Pushoff cylinder systems. When the tractors hydraulic remote is activated, oil flows first to the apron cylinders until they are fully extended. Once the cylinders are fully extended, the apron circuits' hydraulic pressure begins to increase. Once the pressure threshold is surpassed (which is adjustable. See adjustment section), the sequence valve diverts the oil flow to the pushoff's hydraulic circuit. Once the pushoff is completely extended the operator then reverses the tractors hydraulic remote. This will direct oil first to the Apron circuit. Once the aprons cylinders are fully retracted, again the hydraulic pressure begin to increase allowing the pushoff to retract fully once the oil has been diverted from the sequence valve.

INSTRUCTIONS for establishing sequence valve setting:

Remove acorn nut from end of sequence valve with a 1/2" wrench. Turn adjustment screw, using a 4mm hex wrench, clockwise until front apron rises before the push-off advances while the earthmover is empty. Turn the adjustment screw an additional 1/4 turn clockwise, then replace the acorn nut and tighten. Torque check valve assembly and internal pilot plug to 25 ft.-lbs. maximum.

Limited Warranty Statement

Ashland Industries Inc. warrants each new product to be free from defects in material and workmanship. This warranty is applicable only for the normal service life expectancy of the product or components, not to exceed six consecutive months from the date of delivery of the new Ashland Industries product to the original purchaser, or the date the product is first put into service via a rental agreement or other means, whichever occurs first.

Genuine Ashland Industries Inc. replacement parts and components will be warranted for 30 days from date of purchase, or the remainder of the original equipment warranty period, whichever is longer.

Under no circumstances will it cover any merchandise or components thereof, which in the opinion of the company, has been subjected to misuse, unauthorized modification, alterations, an accident or if repairs have been made with parts other than those obtained through Ashland Industries Inc.

Ashland Industries Inc. in no way warrants Tires since these items are warranted separately by their respective manufacturer. Please call Ashland Industries Inc. to receive phone numbers of tire suppliers.

Ashland Industries Inc. in no way warrants wearable items such as cutting edges, front dolly wheel balls, socket halves.

Our obligation under this warranty shall be limited to repairing or replacing, free of charge to the original purchaser, any part that, in our judgement, shall show evidence of such defect, provided further that such part shall be returned within 30 days from the date of failure to Ashland Industries Inc. routed through the dealer and distributor from whom the purchase was made, transportation charges prepaid. Upon warranty approval proper credits will be reimbursed for transportation.

This warranty shall not be interpreted to render Ashland Industries Inc. liable for injury or damages of any kind or nature to person or property. This warranty does not extend to the loss revenue, extra labor cost associated with downtime, substitute machinery, rental or for any other reason.

Except as set forth above, Ashland Industries Inc. shall have no obligation or liability of any kind on account of any of its equipment and shall not be liable for special or consequential damages. Ashland Industries Inc. make no other warranty, expressed or implied, and, specifically, Ashland Industries Inc. disclaims any implied warrant or merchantability or fitness for a particular purpose. Some states or provinces do not permit limitations or exclusions of implied warranties or incidental or consequential damages, so the limitations or exclusion in this warranty may not apply.

This warranty is subject to any existing conditions of supply which may direct affect our ability to obtain materials or manufacture replacement parts.

Ashland Industries Inc. reserves the right to make improvements in design or changes in specifications at any time, without incurring any obligation to owners of units previously sold

No one is authorized to alter, modify or enlarge this warranty nor the exclusion, limitations and reservations.

Ashland Industries Inc.
Warranty Department