

Ashland EARTHMOVERS



I-155-TS2 PARTS MANUAL

ver 5-08



Ashland Industries Inc.
1115 Rail Drive
P.O. Box 717
Ashland, WI. 54806
877-634-4622 Toll Free - phone
715-682-4622 phone
715-682-9717 fax
www.ashlandind.com



I-155 TS2

How to Order Parts



HOW TO ORDER PARTS:

IMPORTANT

Parts must be ordered through your local authorized ASHLAND dealer.

Be sure to state MODEL and SERIAL NUMBER of your machine, PART NUMBER, DESCRIPTION and QUANTITY needed.



Unless this is done, we cannot provide prompt service or assure shipment of the correct parts.

Ashland Industries weldable replacement parts are available to rebuild, modify or update your scraper to current factory specifications.

INDEX

Page 2	Safety Guidelines
Page 3	Operators and Maintenance Instructions
Page 4	Transport Lock-up Links
Pages 5-6	Swivel Hitch Assembly – Illustration and Parts List
Page 7	Apron Assembly – Illustration and Parts List
Page 8	Front End Assembly – Illustrations and Parts List
Page 9	Bowl and Frame – Illustration and Parts List
Page 10	Push Off Gate Assembly – Illustration and Parts List
Page 11	Rear Wheel and Hub Assembly – Illustration and Parts List
Page 12	Apron Cylinder 4" x 13" – Illustration and Parts List
Page 13	Lift Cylinder 5" x 20" – Illustration and Parts List
Page 14	Push Off Cylinder – 5" x 60" – Illustration and Parts List
Page 15	Nitrogen/Hyd. Accumulator – Illustration and Parts List
Page 16	Decals – Illustration and Parts List
Page 17	Hydraulic Valve – Identification, Illustration, Parts List and Adjustment
Page 18-20	Service Manual Appendix
Page 21	Troubleshooting
Page 22	Warrantee Statement

I-155 TS2

Safety Guidelines



SAFETY SIGNAL WORDS

Note the use of the signal words **DANGER**, **WARNING** and **CAUTION** with the safety messages. The appropriate signal word for each has been selected using the following guidelines:



DANGER: Indicates an imminently hazardous situation that, if not avoided, will result in death or serious injury.

This signal word is to be limited to the most extreme situations typically for machine components which, for functional purposes, cannot be guarded.



WARNING: Indicates a potentially hazardous situation that, if not avoided, could result in death or serious injury, and includes hazards that are exposed when guards are removed. It may also be used to alert against unsafe practices.



CAUTION: Indicates a potentially hazardous situation that, if not avoided, may result in minor or moderate injury. It may also be used to alert against unsafe practices.



GENERAL SAFETY GUIDELINES

Safety of the operator is one of the main concerns in designing and developing a new piece of equipment. Designers and manufacturers build in as many safety features as possible. However, every year many accidents occur which could have been avoided by a few seconds of thought and a more careful approach to handling equipment. You, the operator, can avoid many accidents by observing the following precautions in this section. To avoid personal injury, study the following precautions and insist those working with you, or for you, follow them.

Replace any **CAUTION**, **WARNING**, **DANGER** or instruction safety decal that is not readable or is missing. Location of such decals is indicated in this booklet.

Do not attempt to operate this equipment under the influence of drugs or alcohol.

Review the safety instructions with all users annually.

This equipment is dangerous to children and persons unfamiliar with its operation. The operator should be a responsible adult familiar with farm machinery and trained in this equipment's operations. **Do not allow persons to operate or assemble this unit until they have read this manual and have developed a thorough understanding of the safety precautions and of how it works.**

To prevent injury or death, use a tractor equipped with a Roll Over Protective System (ROPS). Do not paint over, remove or deface any safety signs or warning decals on your equipment. Observe all safety signs and practice the instructions on them.

Never exceed the limits of a piece of machinery. If its ability to do a job, or to do so safely, is in question - **DON'T TRY IT.**

I-155 TS2

Operators and Maintenance Instructions

OPERATORS AND MAINTENANCE INSTRUCTIONS

This scraper is a durable piece of equipment and with proper care will yield many years of trouble free operation. The scraper requires a power source with TWO 4 way (double acting) hydraulic control valves.

The scraper should be greased at all points where grease fittings are provided. Connect hydraulic hoses to the tractor and retract lift cylinders to **REMOVE TRANSPORT LOCK PINS**, then extend and retract all cylinders several times to force out any air from the hydraulic cylinders and lines. Check the oil levels in the tractor hydraulic system and add to maintain the proper level. Care should be used when adding oil or when disconnecting any oil line to keep all dirt out of the oil as dirt is a major factor in the failure of hydraulic components.

When the scraper is placed into operation, the operator will have to "feel out" the amount of depth of cut to obtain maximum loading efficiency. This is usually accomplished by taking a lesser and more uniform cut; however, some soil conditions such as loose sand may require a "pumping action" obtained by taking successive deep cuts and lifting out of cut as the tractor begins to lose power or traction.

1. After 10 hours work, all bolts should be checked and tightened if necessary.
2. Every 10 hours all grease fittings should be lubricated.
3. After 50 hours work, all bolts should be rechecked and tightened if necessary. Check wheel bearings and adjust if necessary.
4. After 300 hours work, clean and repack wheel bearings and replace, if necessary, cutting edges, worn pins, etc.
5. Tighten all wheel bolts after first two hours use. Check daily for two weeks. Keep torqued to 750 ft.lbs.
6. Maintain tire pressure at 45 to 50 psi.

I-155 TS2

Transport Locks



Key Number	Part Number	Description
01	A125006	Pin, Safety Snap Pin
02	A123309-83	Link, Transport Lock, Red

I-155 TS2

Swivel Hitch Assembly

Part Number A125223

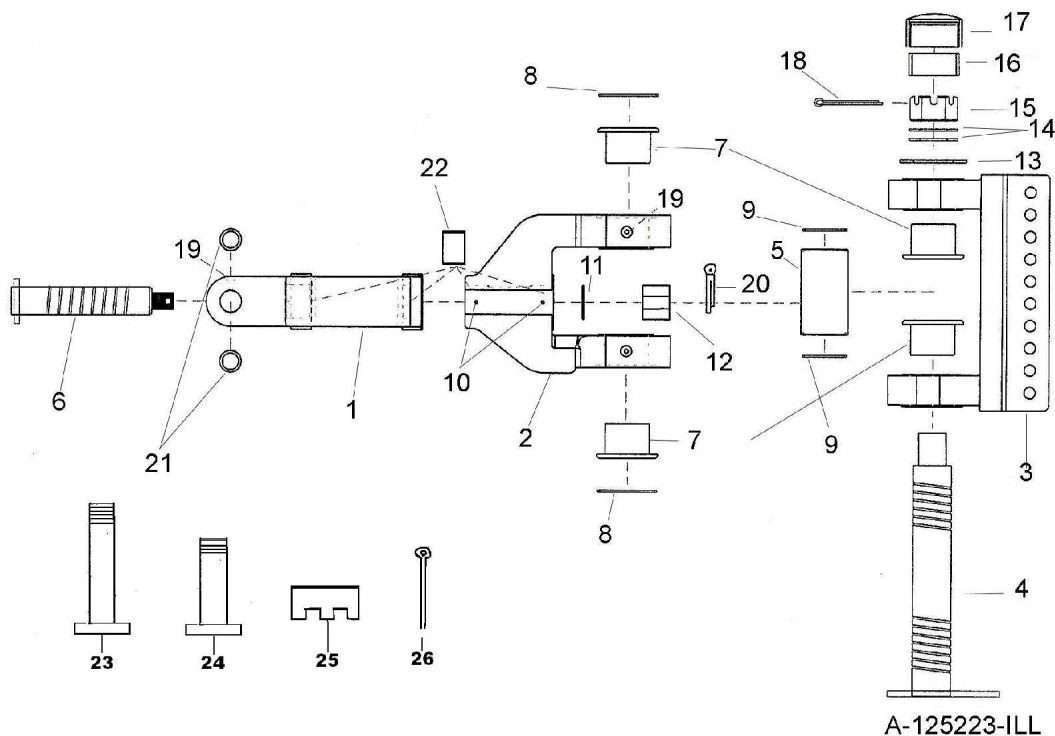

A-125223-ILL

Key Number	Part Number	Description
01	A125223-01	Yoke: A-Frame
02	A125223-02	Swivel
03	A125223-03	Bracket: 10 Hole
04	A125223-04	Pin: Main Vertical
05	A125223-05	Spacer: 6"
06	A125223-06	Pin Horizontal
07	A125223-07	Bushing
08	A125223-08	Seal: O-ring
09	A125223-09	Seal: O-ring
10	AFH-00028	Grease Fitting: 90°
11	A125223-11	Washer- 1-1/2" For Horizontal Pin
12	A125223-12	Nut: Slotted 1-1/2" NC
13	A125223-13	Spacer: 6"
14	A125223-14	Washer: 2 1/2"
15	A125223-15	Nut: Slotted 2-1/2" NC
16	A125223-16	Sleeve: 2" Rubber
17	A125223-17	Cap: For Vertical Pin
18	A125223-18	Pin: Cotter 3/8 x 5"
19	14505	Grease Fitting Straight
20	8613	Cotter Pin: 5/16 x 2-1/2"
21	A125056-24	Bushing
22	A125056-27	Bushing
23	A123299-07	Pin: Two Ear Draw Bar to Hitch
24	A123299-08	Pin: Four Ear Drawbar to Hitch
25	AFN-00014	1 1/2" Slotted Nut
26	AFP-00001	1/4" X 3" Cotter Pin

I-155 TS2

Icon Swivel Hitch (Optional) Part Number A125224

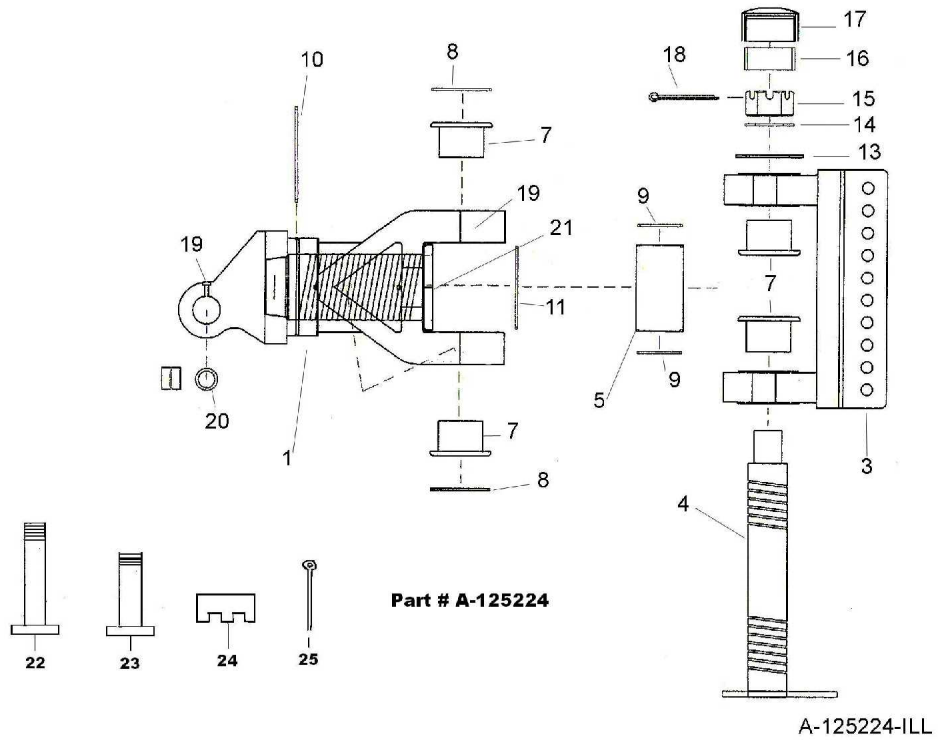

Key Number	Part Number	Description
01	A125224-01	Yoke: A-Frame swivel
03	A125224-03	Bracket: 10 Hole
04	A125224-04	Pin: Main Vertical
05	A125224-05	Spacer: 6"
07	A125224-07	Bushing
08	A125224-08	Seal: O-ring
09	A125224-09	Seal: O-ring
10	A125224-10	O-ring
13	A125224-13	Spacer: 6"
14	A125224-14	Washer: 2 1/2"
15	A125224-15	Nut: Slotted 2-1/2" NC
16	A125224-16	Sleeve: 2" Rubber
17	A125224-17	Cap: For Vertical Pin
18	A125224-18	Pin: Cotter 3/8 x 5"
19	14505	Grease Fitting Straight
20	A125056-24	Bushing
21	AHF-00027	Zerk 45°
22	A123299-07	Pin: Two Ear Drawbar to Hitch
23	A123299-08	Pin: Four Ear Drawbar to Hitch
24	AFN-00014	1 1/2" Slotted Nut
25	AFP-00001	1/4" X 3" Cotter Pin

I-155 TS2

Apron Assembly

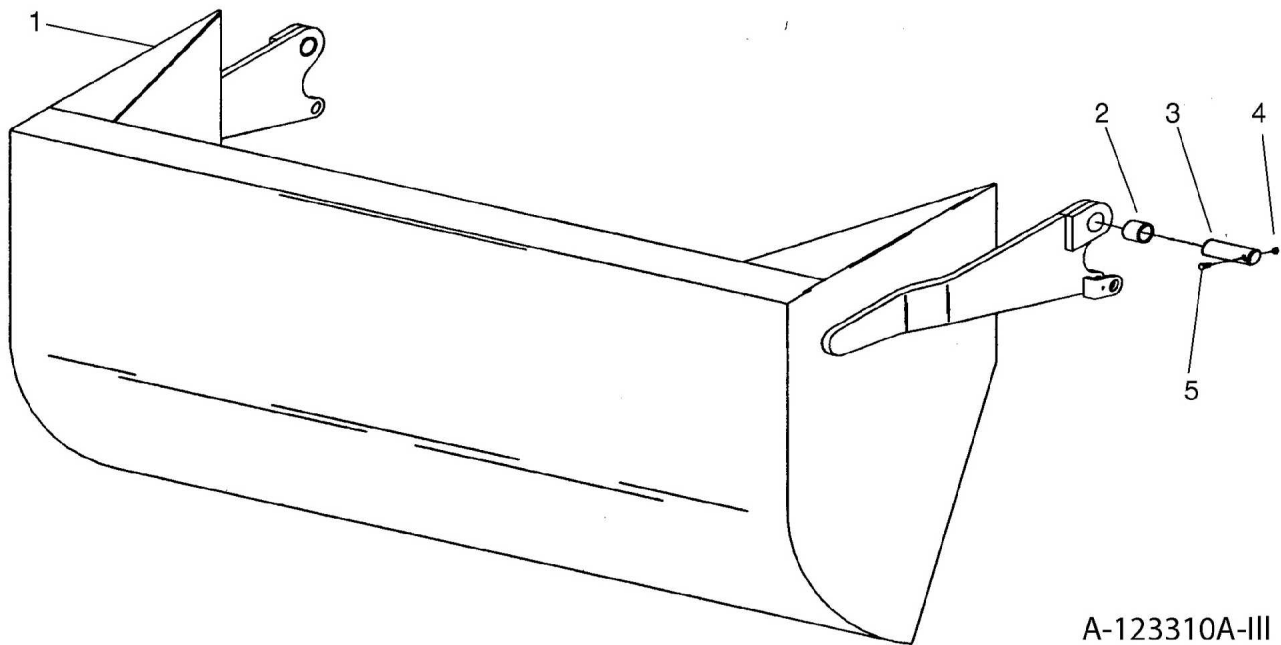

A-123310A-III

Key Number	Part Number	Description
01	A123310A	Apron Model I-155 TS
02	A16027	Bushing: 2" OD x 1-1/2" ID x 2" Long
03	A123337	Pin: 1-1/2" x 5-3/8"
04	7450	Nut: 3/8" NC
05	AFB-00049	Bolt: 3/8" NC x 3"

I-155 TS2

FRONT END (s.n. 20412 and up)

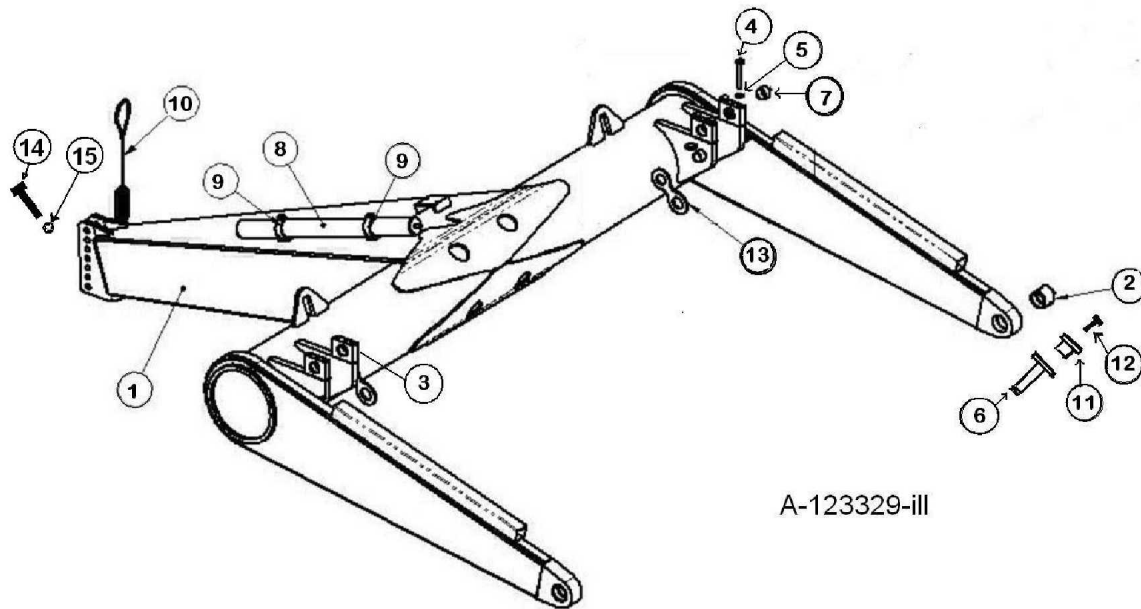

A-123329-III

Key Number	Part Number	Description
1	A123329	Front End Assembly
2	A123320-08	Bronze Bushing: 3"ID X 3 1/2 OD X 3"L
3	A123456	Trunion Mount Block
4	AFB-00039	Bolts, 3/4" X 5 1/2"
5	AFW-00002	Lockwasher, 3/4"
6	A123321-09	Pin: Main Frame Attachment
7	A125179	Bushing for Trunion Mount Block
8	A125005	Accumulator
9	A125009	Mounting Brackets
10	A125109A	Hose Support
11	A123358	Flanged Bolt Bushing
12	AFB-00079	Bolt: 5/8" X 1 1/2" Gr 8
13	A123320-20	Travel Lock
14	AFB-00021	Bolt: 1" X 5 1/2" NC Gr. 8 (9 Reqd).
15	AFN-00037	Nut: 1" NC Locknut (9 Reqd).

I-155 TS2

Bowl & Frame Assembly

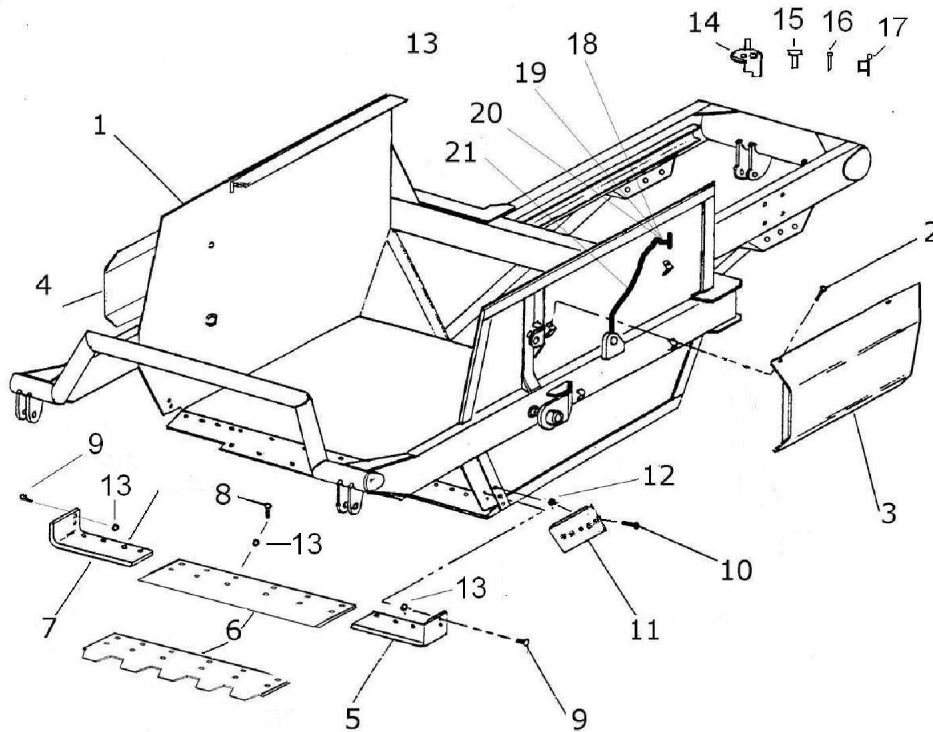

A-123309-III

Blade Bolts Required:

		<u>Qty</u>	<u>Bolts</u>
A123330 (& Ser)	PB9P-NC-088-0275	(12)	AFN-00019
A123332L & R	PB9P-NC-088-0275	(4)	AFN-00019
	PB9P-NC-088-0225	(2)	
A123357	AFB-00018	(4)	AFN-00012

<u>Key Number</u>	<u>Part Number</u>	<u>Description</u>
1	A123309	Bowl and Frame, Model I-155
2	AFB-00094	Flanged Bolt: 3/8 NC X 1"
3	A123309-62L	Cylinder Guard - Left Hand
4	A123309-62R	Cylinder Guard - Right Hand
5	A123332L	Left Cutting Edge
6	A123330	Center Cutting Edge, Straight 1-1/8" x 12" x 63"
	A123330SER	Center Cutting Edge, Serrated 1-1/8" x 12" x 63"
7	A123332R	Right Cutting Edge
8	PB9P-NC-088-0275	Plow Bolt 7/8" x 2-3/4"
9	PB9P-NC-088-0225	Plow Bolt 7/8" X 2 1/4"
10	AFB-00018	Bolt, 1" NC x 3" long, 5 per Blade Required
11	A123357	Bank Shaver/router bit Reversible, L & R
12	AFN-00012	Nut: 1" NC, 5 per Blade Required
13	AFN-00019	Nut: 7/8" NC
14	A123309-93	3" Locking Lug for Rear Hitch
15	A123309-96	Pin (2 Reg) for Locking Lug
16	AFP-00001	Pin Cotter, 1/4" x 3"
17	A125006	Safety Snap Pin
18	A125019	Grease Fitting 1/4 x 28.54 long
19	A125026	Bulkhead Nut
20	A123306-89	Single Hole Tab
21	A125022	18" Grease Line

I-155 TS2

Pushoff Gate Assembly

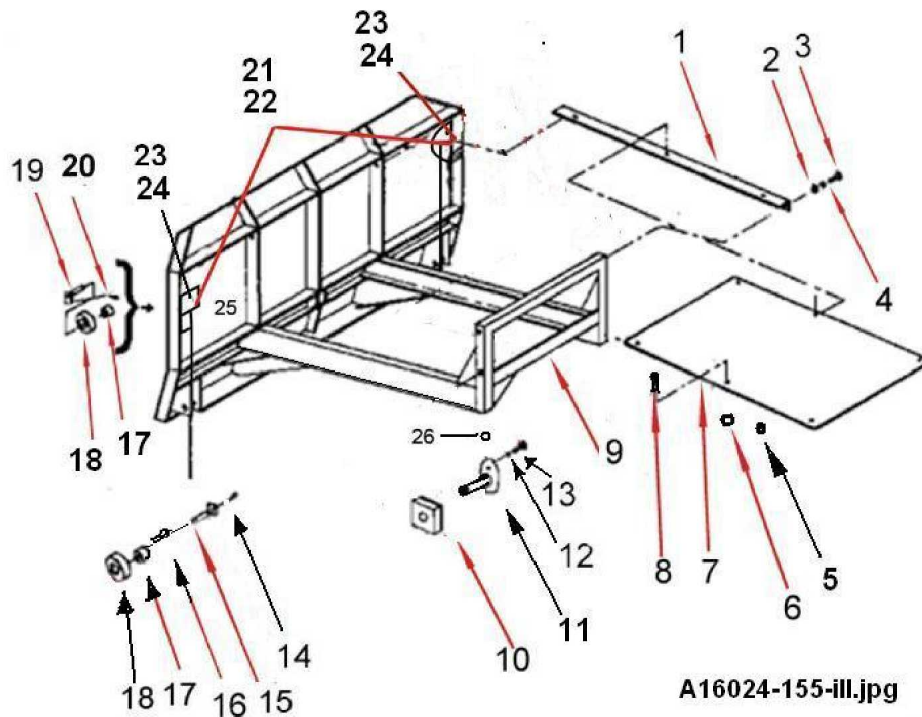

Key Number	Part Number	Description
1	A14022	Brace
2	AFN-00006	Nut: 3/4" NC
3	AFB-00037	Bolt: 3/4" NC x 2" Lg.
4	AFW-00002	Lockwasher: 3/4"
5	8100	Lockwasher: 1/2"
6	AFN-00015	Nut: 1/2" NC
7	A14023	Dirt Shield
8	AFB-00015	Bolt: 1/2" NC x 1-1/2"
9	A16024	Pushoff Gate: Model I-150
10	A123353	Wear Pad
11	A123305A	Pin: 1-1/4 X 2-3/4" for Wear Pad
12	8100	Lockwasher: 1/2"
13	AFB-00033	Bolt: 1/2 NC X 2-1/2"
14	AHF-00028	Grease Fitting: 1/8" NPT -90 degree
15	A6007A	Pin: 1-1/4" x 4-1/8" Lg.
16	AFP-00001	Cotter Pin: 1/4 X 3-1/2"
17	A10163	Bushing: 1-3/4" OD x 1-1/4" ID
18	A10164	Roller: 4-1/4 OD X 1-3/4 ID.
19	A123323-21	Pin: 1-1/4 X 4 1/8" Tab Head
20	7036	Bolt: 1/2 NC X 2"
21	A125020	Remote Grease Lines, 32"
22	A125021	Remote Grease Lines, 54"
23	A125019	Grease Fitting 1/4 x 28.54 Long
24	A125026	BulkHead Nut
25	A123323-40	Double Hole Tab
26	7500	1/2" Nut

I-155 TS2

REAR WHEEL and HUB ASSEMBLY - 7 Hole Spindle

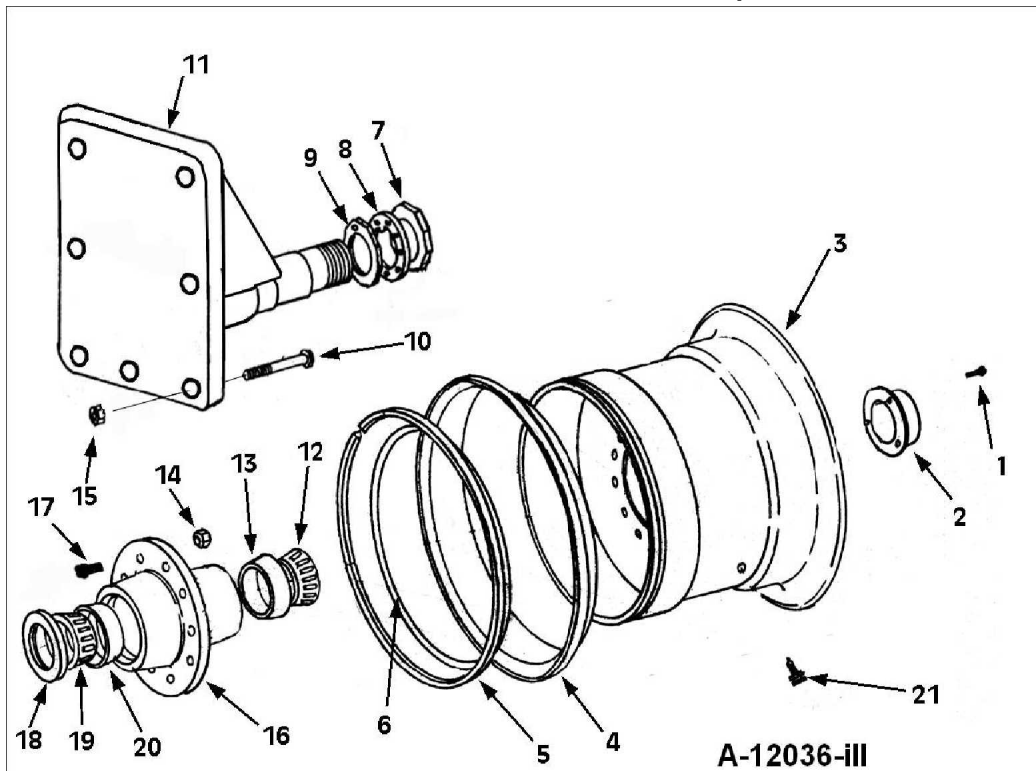

A-12036-III

Key Number	Part Number	Description
01	AFB-00080	Bolt 5/16" NC x 1/2" Lg.
2	A14004	Hub Cap
3	A12036	Wheel Ass'y. 25" x 25"
	A12036-1	Center Dish Weldment, Flat
	A12036-2	Six Gussets for Center Dish
4	A12041	Side Ring
5	A12042	Lock Ring
6	A12047	O-Ring
7	A10048	Spindle Nut
8	A10049A	Lock Collar
9	A10172	Nut with Lock Pin
10	AFB-00067	Bolt 1-1/4" NF X 7-1/2" Lg.
11	A123350	Spindle
12	A125001	Bearing Cone
13	A125002	Bearing Cup
14	A12051	Lug Nut
15	AFN-00009	Lock Nut: 1-1/4" NF
16	A12035	Hub
17	A12050	Lug
18	A12037	Grease Seal
19	A125003	Bearing Cone
20	A125004	Bearing Cup
21	A14016	Valve Stem

I-155 TS2

Apron Cylinder 4 x13

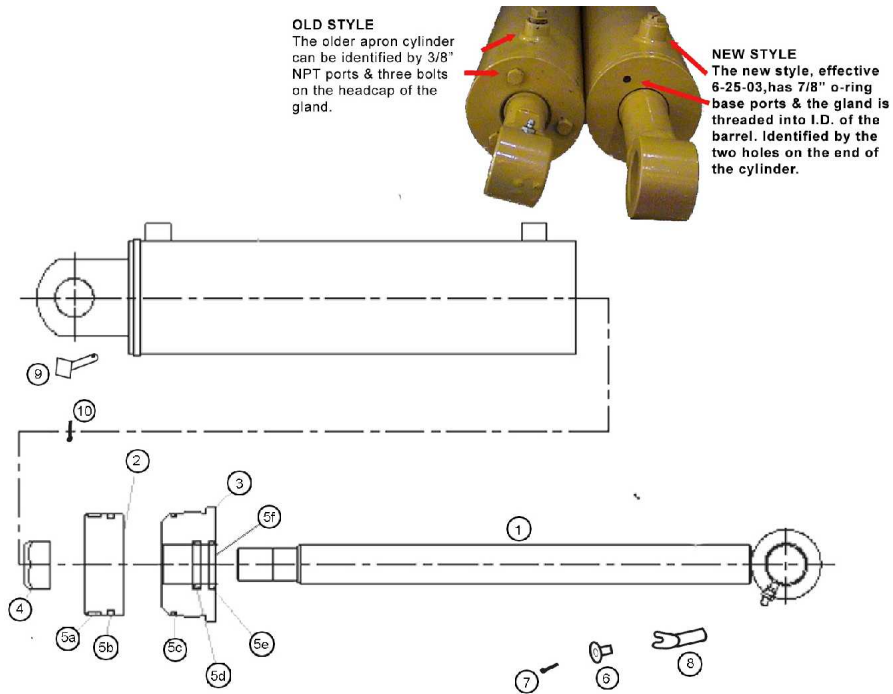

A-125050-III

Key Number	Part Number	Description
01	A125050-01	Rod 1-3/4" with welded eye
02	A125050-02	Piston
03	A125050-03	Gland, Threaded
04	A125050-04	Lock Nut, 1-1/8" NF
05	A125050-05	Seal Kit, a-f
5a	A125050-05a	Nylon Wear Ring
5b	A125050-05b	FSP Seal
5c	A125050-05c	O-Ring
5d	A125050-05d	Backup Washer
5e	A125050-05e	Hallite Rod Seal
5f	A125050-05f	Snap-in Rod Wiper
06	A123362	Pin, 1-1/2" with slot for keeper bushing
07	8602	Pin, Cotter 1/4" x 2" Zinc
08	A123351	Bushing, retaining flange, 9/16" ID x 3/4" OD, 3/4" L
09	A123363	Pin: 1-1/2" square head
10	AFB-00015	HHCS 1/2" NC x 1-1/2" Gr. 8

I-155 TS2

LIFT CYLINDER 5 X 20

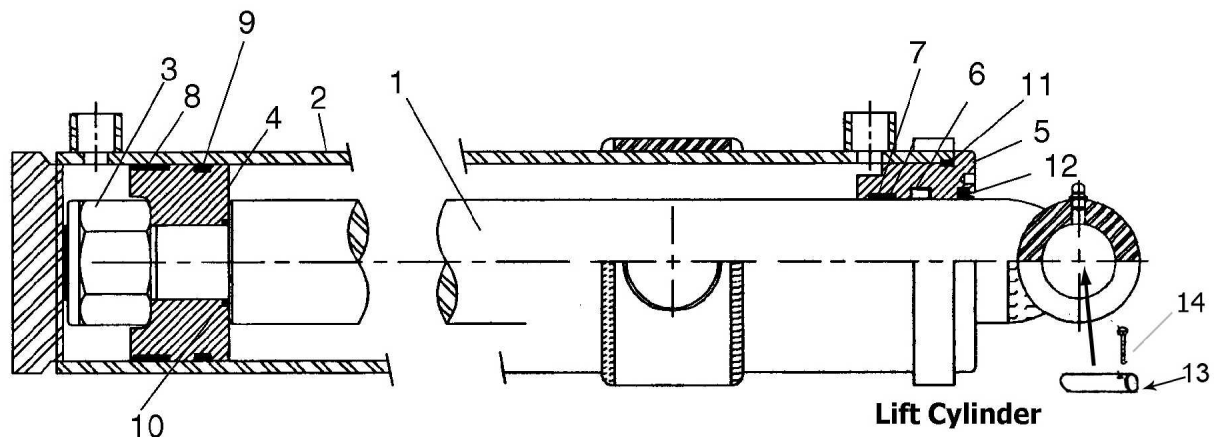

A-123326-III

Key Number	Part Number	Description
01	A123326-1	Piston Rod: 2-1/2"
02	A123326-2	Barrel Weldment
03	A125159-34	1-3/4 NF Locknut
04	A123324-4	Piston
05	A123324-5	Gland
06	A123324-6	Rod Seal
07	A123324-3	Wear Band
08	A123324-8	Wear Ring
09	A123324-9	Piston Seal
10	A123324-10	O-Ring
11	A123324-11	O-Ring
12	A123324-7	Rod Wiper
	AHS-00140	Seal Kit (Items 6-12)
13	A123335	Pin, 2" x 10-1/2" lg.
14	AFP-00001	Cotter Pin, 1-4" x 3"

I-155 TS2

PUSHOFF CYLINDER 5 X 60 Part No. A125177

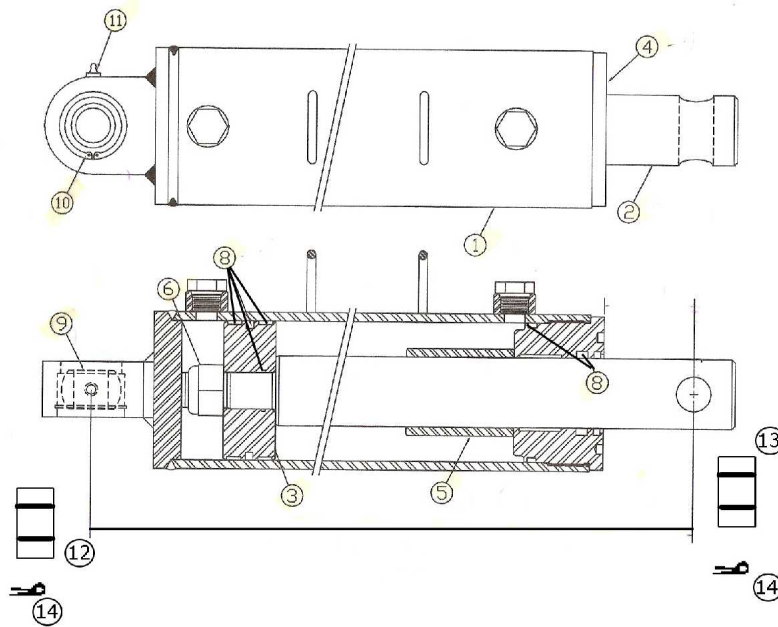

Key Number	Part Number	Description
1	A125177-10	Barrel Weldment
2	A125177-20	Shaft
3	A125177-30	Piston
4	A125177-31	Head
5	A125176-32	Spacer
6	A125175-33	1 1/4" Nylock Nut
8	A125177-40	Seal Kit
09	A125175-35	Bearing
10	A125175-36	Snap Ring
11	A125175-37	Grease Zerk
12	A9024	Pin 1-1/4 x 4-3/4 Lg
13	A14033	Pin 1-1/4 x 5 Lg
14	AFP-00001	Cotter Pin 1/4 x 2

I-155 TS2

Nitrogen over Hydraulic Accumulator

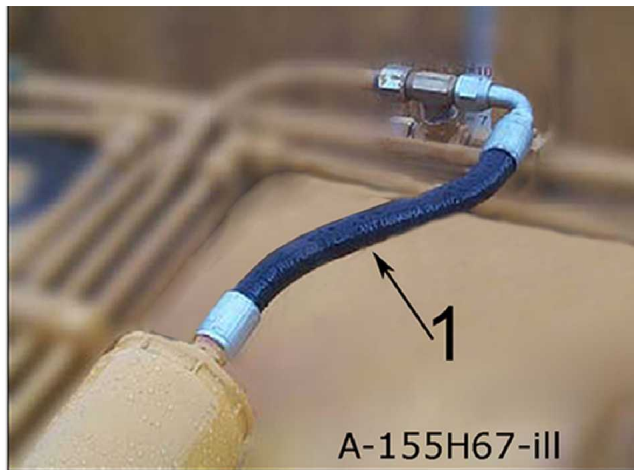

This accumulator is rated at 4,000 psi and is pre-charged at the plant at 2,800 psi. any circuit pressure above 2,800 will bleed off into this accumulator until it reaches 2.11 gallons of hydraulic oil displacement. This accumulator can be recharged with nitrogen however the accumulator is NOT REBUILDABLE.

Key Number	Part Number	Description
01	A155H67	Hose, 3/4" x 16" MORB with sweep
02	A125009	Bracket, Welded with bolts
03	A125005	Accumulator Cylinder

I-155 TS2

Decals



I-155-decals-ill

Key Number	Part Number	Description
01	ADS-00003	Decal Blade Wedge, Gradient
02	ADS-00001	Decal Ashland Logo, Large
03	ADS-00011	Decal Pinch Point,
04	ADS-00004	Decal I-155 Numerals only
05	ADS-00005	Decal "TS"
06	ADS-STRIPEKIT	Decal Stripes
07	A123286	Decal Apron opening
09	ADS-00015	Decal "when pulling in tandem"
10	750464	Decal "Hydraulic Pressure"
11	ADS-00002	Decal Small "Ashland"

I-155 TS2

Hydraulic Manifold Assembly

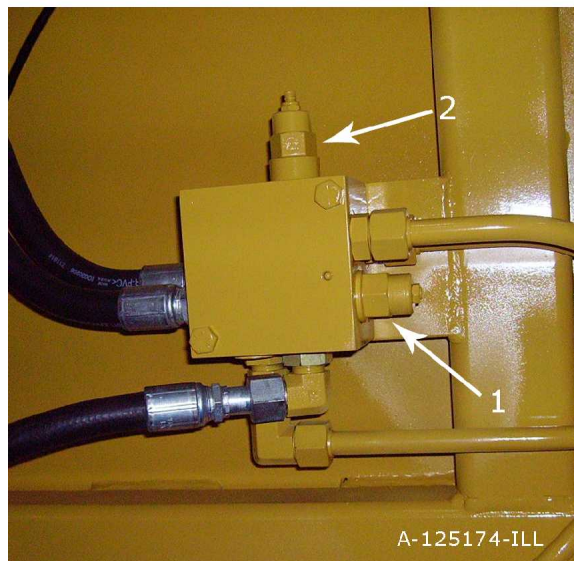

IMPORTANT: This Hyd. Manifold was intergrated into production April, 2006 It replaces A125070 valve.

For older machines see master parts book on Ashlandind.com.

HYDRAULIC MANIFOLD ASSEMBLY

A125174

SETTING THE APRON AND PUSHOFF VALVE

The manifold block containing the pushoff sequence valve cartridge and apron sequence valve cartridge is used to control two hydraulic circuits with one hydraulic remote. when the tractor hydraulic remote is activated, oil flows first to the apron cylinders until they are fully extended. Once the cylinders are fully extended, the apron circuits' hydraulic pressure begins to increase. Once the pressure threshold is surpassed (which is adjustable. See adjustment section), the sequence valve diverts the oil flow to the pushoff's hydraulic circuit. Once the push off is completely extended the operator then reverses the tractors hydraulic remote. The counterbalance valve will hold the apron open until the push off is fully retracted. The Apron sequence valve then opens and allows the apron to close.

Setting the valves:

STEP 1 PUSHOFF SEQUENCE VALVE

Loosen the lock nut (9/16") on the sequence valve cartridge. Turn the setscrew (4mm) clockwise until the front apron rises before the push-off begins to advance. (Earthmover should be empty) Turn the adjustment screw an additional 1/4 turn clockwise and tighten jam nut.

STEP 2 Counter Balance VALVE

Loosen the lock nut (9/16") on the counterbalance valve cartridge. Turn the setscrew (4mm) counter-clockwise until the apron holds in a raised position while rear gate is being retracted. Turn adjustment screw an additional 1/4 turn, tighten jam nut. DO NOT tighten adjusting screw more than necessary.

Key Number	Part Number	Description
01	A125162-01	CounterBalance Cartridge
02	A125162-02	Sequence Cartridge

MAINTENANCE CHECKLIST

1. Grease all zerks.
 - a) Every 8 hours of operation.
 - b) See Lubrication Points section on next page.

2. Greasing the hubs.
 - a) Re-pack wheel bearings after 600 hrs of operation.
 - b) Completely clean grease out of hub and bearings every 1200 hours of operation.

3. Check tire pressure.
 - a) 20.5 - 25, 12-ply tire requires a tire pressure of 35-40 psi on a rear machine, 40-50 on a front machine.

4. Check all pins for signs of wear.
 - a) Daily

5. Check wheel lug nut torque.
 - a) After first 2 hours of operation.
 - b) Recheck daily for next 2 weeks.
 - c) Tighten wheel lug nuts in a star pattern.
 - d) Torque wheel lug nuts to 450 ft-lbs.

6. Check and retighten all bolts.
 - a) After initial 10 hours of use.
 - b) Again after 50 hours of use.
 - c) See Torque Specifications on next page.

7. Inspect cutting edges.
 - a) Daily
 - b) Replace cutting edges when center blade has been worn to approximately 6" and side edges worn to approximately 4".



CAUTION! Failure to replace worn cutting edges may result in unnecessary wear to the earthmover sides and floor.

Note: Please specify left or right "L" shaped cutting edges when ordering replacements.

I-155 TS2

TORQUE SPECIFICATIONS

<i>Bolt Diameter</i>	<i>Torque Ft-lbs</i>
<i>1/4</i>	<i>12</i>
<i>5/16"</i>	<i>25</i>
<i>3/8"</i>	<i>45</i>
<i>7/16"</i>	<i>70</i>
<i>1/2"</i>	<i>110</i>
<i>9/16"</i>	<i>150</i>
<i>5/8"</i>	<i>220</i>
<i>3/4"</i>	<i>380</i>
<i>7/8"</i>	<i>600</i>
<i>1"</i>	<i>900</i>
<i>1-1/8"</i>	<i>1280</i>
<i>Lug Nuts</i>	<i>750</i>

LUBRICATION

1. Grease all zerks every 8 hrs of operation with high quality, general-purpose grease.
 - a) Grease until grease flows from around pin.

Lubrication Points (see Ill.)

1. Hitch – Horizontal and vertical pins.
2. Lift Cylinders – Rod end & Trunion; Both left & right sides.
3. Front Arm Pivot Joint – Both left & right sides.
4. Apron Cylinders – Rod clevis pin; Both left & right sides.
5. Apron Pivot Pin – Both left & right sides.
6. Hold-down Rollers – Both left & right sides.
7. Floor Rollers – Both left & right sides.
8. Tapered Rollers – Both left & right sides.



PUSHING THE EARTHMOVER

The I-155TS was designed to be pushed when equipped with the optional push-bar. However, Ashland Industries, Inc. **STRONGLY** recommends using extreme caution when pushing the I-155TS earthmover to prevent any unnecessary damage.

CAUTION! The I-155TS earthmover must be pushed in a straight line with a maximum of a 100 hp dozer. Do not ram or jar the earthmover while pushing and push at a constant speed.

Introduction

With proper care and maintenance, the I-110TS will give many years of reliable service. When a situation arises where the earthmover performance is not satisfactory, this section will give some pointers on finding and correcting the problem.

Grease zerk will not take grease.

1. Grease zerk plugged.
 - a) Remove and replace grease zerk.
 2. Pin is frozen.
 - a) Remove, clean, and inspect pin.
 - b) Replace pin if necessary.
 3. Bushing grease passage is not aligned with grease zerk.
 - a) Remove, clean, inspect, and realign bushing.
 - b) Replace bushing if necessary and realign.
-

Push-off rollers do not roll.

1. The rollers need lubrication.
 - a) Check zerk hole and grease.
 - b) Remove pin, clean, inspect, and replace if necessary.
 2. The roller bushing is worn out.
 - a) Remove roller assembly and replace bushing.
 - b) See parts manual.
-

Cylinders will not hold in preset position, i.e. the cylinder creeps.

1. Seals leaking internally.
 - a) Remove and replace seal kit.
-

Machine cuts unevenly.

1. Cutting edges worn unevenly.
 - a) Replace cutting edges.
 2. Improperly inflated tires.
 - a) Check air pressure in tires.
-

I-155 TS2

Warranty Statement

Limited Warranty Statement

Ashland Industries Inc. warrants each new product to be free from defects in material and workmanship. This warranty is applicable only for the normal service life expectancy of the product or components, not to exceed **six consecutive months** from the date of delivery of the new Ashland Industries product to the purchaser, or the date the product is first put into service via a rental agreement or other means, whichever occurs first.

The major components of swivel hitches used on Industrial series scrapers are warranted for three consecutive months from the date of delivery of the new Ashland Industries product to the purchaser, or the date the product is first put into service via a rental agreement or other means, whichever occurs first, except those components described below.

Genuine Ashland Industries Inc. replacement parts and components will be warranted for 30 days from date of purchase, or the remainder of the original equipment warranty period, whichever is longer.

Under no circumstances will it cover any merchandise or components thereof, which in the opinion of the company, has been subjected to misuse, unauthorized modification, alterations, an accident or if repairs have been made with parts other than those obtained through Ashland Industries Inc.

Ashland Industries Inc. in no way warrants Tires since their respective manufacturer warrants these items separately. Please call Ashland Industries Inc. to receive phone numbers of tire suppliers.

Ashland Industries Inc. in no way warrants wearable items such as cutting edges, front dolly wheel balls, socket halves, rollers, bushings, yoke hitch pins, hitch bushings, etc..

Our obligation under this warranty shall be limited to repairing or replacing, free of charge to the original purchaser, any part that, in our judgement, shall show evidence of such defect, provided further that such part shall be returned within 30 days from the date of failure to Ashland Industries Inc. routed through the dealer and distributor from whom the purchase was made, transportation charges prepaid. Upon warranty approval proper credits will be reimbursed for transportation.

This warranty shall not be interpreted to render Ashland Industries Inc. liable for injury or damages of any kind or nature to person or property. This warranty does not extend to the loss revenue, extra labor cost associated with downtime, substitute machinery, rental or for any other reason.

Except as set forth above, Ashland Industries Inc. shall have no obligation or liability of any kind on account of any of its equipment and shall not be liable for special or consequential damages. Ashland Industries Inc. make no other warranty, expressed or implied, and, specifically, Ashland Industries Inc. disclaims any implied warrant or merchantability or fitness for a particular purpose. Some states or provinces do not permit limitations or exclusions of implied warranties or incidental or consequential damages, so the limitations or exclusion in this warranty may not apply.

This warranty is subject to any existing conditions of supply which may direct affect our ability to obtain materials or manufacture replacement parts.

Ashland Industries Inc. reserves the right to make improvements in design or changes in specifications at any time, without incurring any obligation to owners of units previously sold

No one is authorized to alter, Modify or enlarge this warranty nor the exclusion, limitations and reservations.

Ashland Industries Inc.
Warranty Department