



# I-150-SP PARTS MANUAL

Updated 3/21/01



Ashland Industries Inc.  
Hwy. 13 South  
P.O. Box 717  
Ashland, WI. 54806  
877-634-4622 Toll Free - phone  
715-682-4622 phone  
715-682-9717 fax  
[www.ashlandind.com](http://www.ashlandind.com)





## HOW TO ORDER PARTS:

### IMPORTANT

Parts must be ordered through your local authorized Ashland Industries dealer.

Be sure to state Model and Serial Number of your machine, part number, description and quantity needed.

Unless this is done, we cannot provide prompt service or assure shipment of correct parts.

## INDEX

Page 3.	Operators and Maintenance Instructions
Page 4.	Illustration and Parts List - Swivel Hitch
Page 5.	Illustration and Parts List - Apron Assembly
Page 6.	Illustration and Parts List - Front End Assembly
Page 7.	Illustration - Bowl and Frame
Page 8.	Parts List - Bowl and Frame
Page 9.	Illustration and Parts List - Push Off Gate Assembly
Page 10.	Illustration and Parts List - Rear Wheel and Hub Assembly
Page 11.	Illustration and Parts List - Apron Cylinder 4" X 13"
Page 12.	Illustration and Parts List - Lift Cylinder 5" X 20"
Page 13.	Illustration - Push Off Cylinder 5" x 60"
Page 14.	Parts List - Push Off Cylinder 5" x 60"
Page 15-19	Service Manual Appendix
Page 20-22	Troubleshooting
Page 23.	Warranty Statement

# OPERATORS AND MAINTENANCE INSTRUCTIONS

The scraper is a durable piece of equipment and with proper care will yield many years of trouble free operation. The scraper requires a power source with TWO 4 way (double acting) hydraulic control valves.

The scraper should be greased at all points where grease fittings are provided. Connect hydraulic hoses to the tractor and retract lift cylinders to remove transport lock pins, then extend and retract all cylinders several times to force out any air from the hydraulic cylinders and lines. Check the oil levels in the tractor hydraulic system and add to maintain the proper level. Care should be used when adding oil or when disconnecting any oil line to keep all dirt out of the oil as dirt is a major factor in the failure of hydraulic components.

When the scraper is placed into operation, the operator will have to "feel out" the amount of depth of cut to obtain maximum loading efficiency. This is usually accomplished by taking a lesser and more uniform cut. However, some soil conditions such as loose sand may require a "pumping action" obtained by taking successive deep cuts and lifting out of cut as the tractor begins to lose power or traction.

1. After 10 hours work, all bolts should be checked and tightened if necessary.
2. Every 10 hours all grease fittings should be lubricated.
3. After 50 hours work, all bolts should be rechecked and tightened if necessary. Check wheel bearings and adjust if necessary.
4. After 300 hours work, clean and repack wheel bearings and replace, if necessary, cutting edges, worn pins, etc..
5. Tighten all wheel bolts after first two hours use. Check daily for two weeks. Keep torqued to 750 ft. lbs..
6. Maintain tire pressure at 45 to 50 psi.



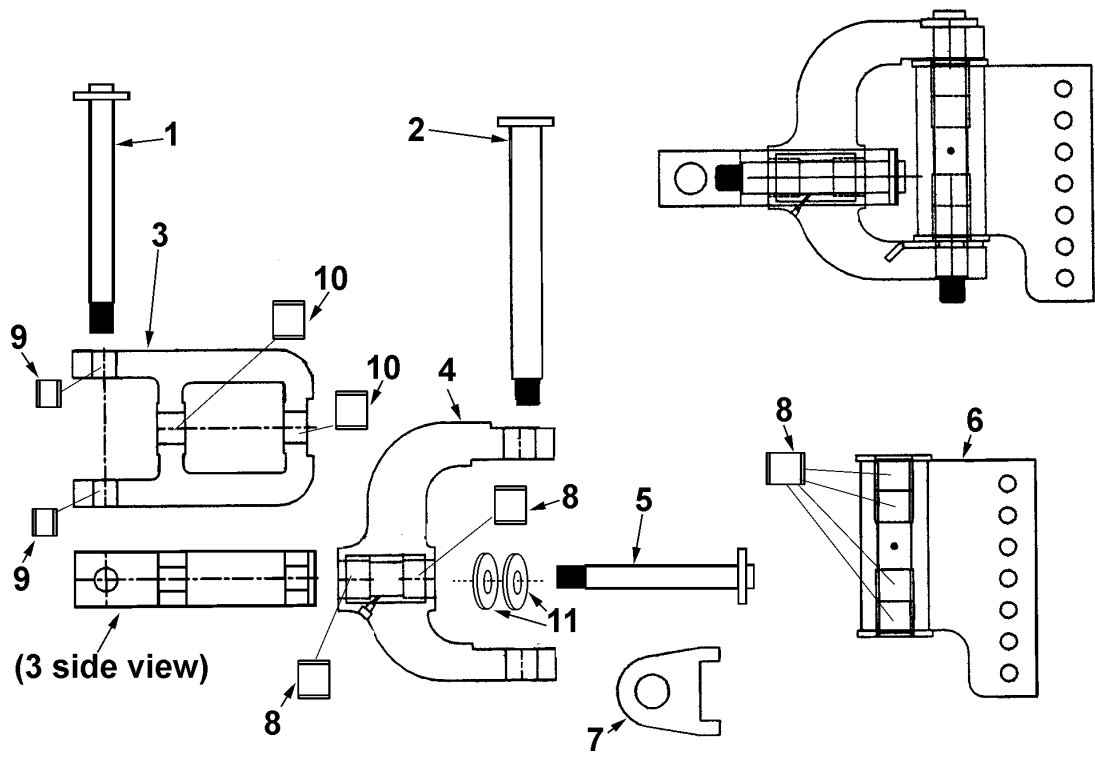

KEY NO.	PART NO.	DESCRIPTION
1.	A123299-08	Pin: Four Ear Drawbar To Hitch
	A123299-07	Pin: Two Ear Drawbar To Hitch
2.	AFN-00014	Nut: 1-1/2" NC Slotted
	A123299-06	Pin: Sq. Tab Head 2 X 18-1/2"
3.	AFN-00018	Nut: 1-1/2" NF Top Lock
	A123299-03R	A-Frame Hitch
4.	A123299-02	C-Frame Hitch: Offset
5.	A123299-05	Pin: Sq. Tab Head 1-1/2 X 12-1/2"
	AFN-00018	Nut: 1-1/2" NF Top Lock
6.	A123299-01	Vertical Mounting Tube: 7 Hole
7.	A123299-04	Wear Pad With Locking Legs
8.	ABS-00001	Bushing: 2-3/8" OD x 2" ID
9.	A123299-09	Bushing: 2" OD x 1-1/2" ID x 1-1/2" (2 req'd)
10.	A123299-10	Bushing: 2-3/8" OD x 2" ID x 1-1/2" (2 req'd)
11.	A123299-11	Washer

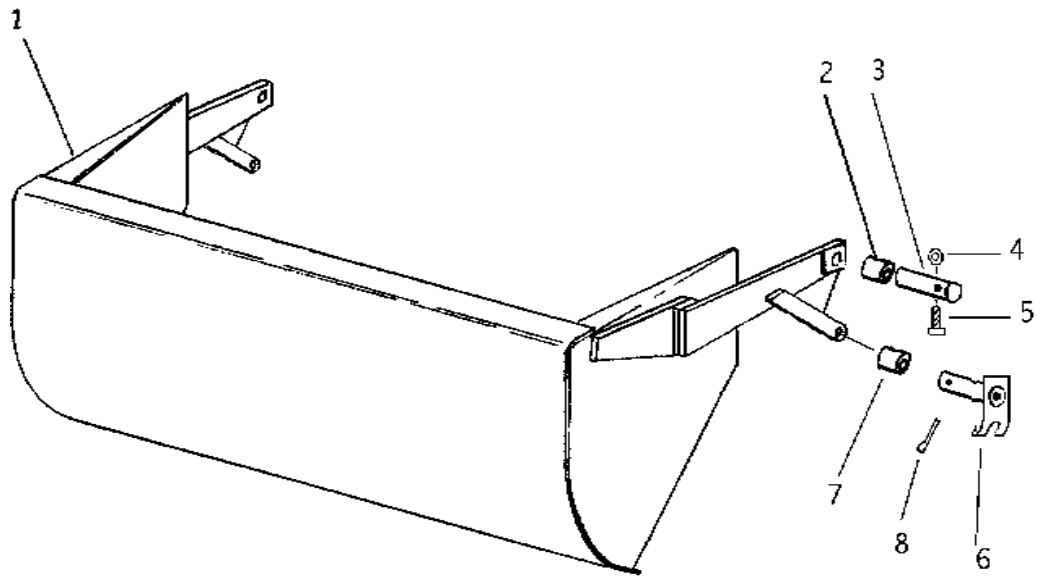

MODEL I-150 SP  
APRON ASSEMBLY

KEY NO.	PART NO.	DESCRIPTION
1.	A16025A	Apron Model I-150
2.	A16027	Bushing: 2" OD x 1-1/2" ID x 2" Long
3.	A6010	Pin: 1-1/2" x 5-1/4"
4.	7450	Nut: 3/8" NC
5.	AFB-00049	Bolt: 3/8" NC x 3"
6.	A10167	Pin: Claw Head w/Grease Fitting 1" x 3-1/16"
7.	A10155	Bushing: 1-1/2" OD x 1" ID x 1" Long
8.		Cotter Pin: 3/16 X 3"

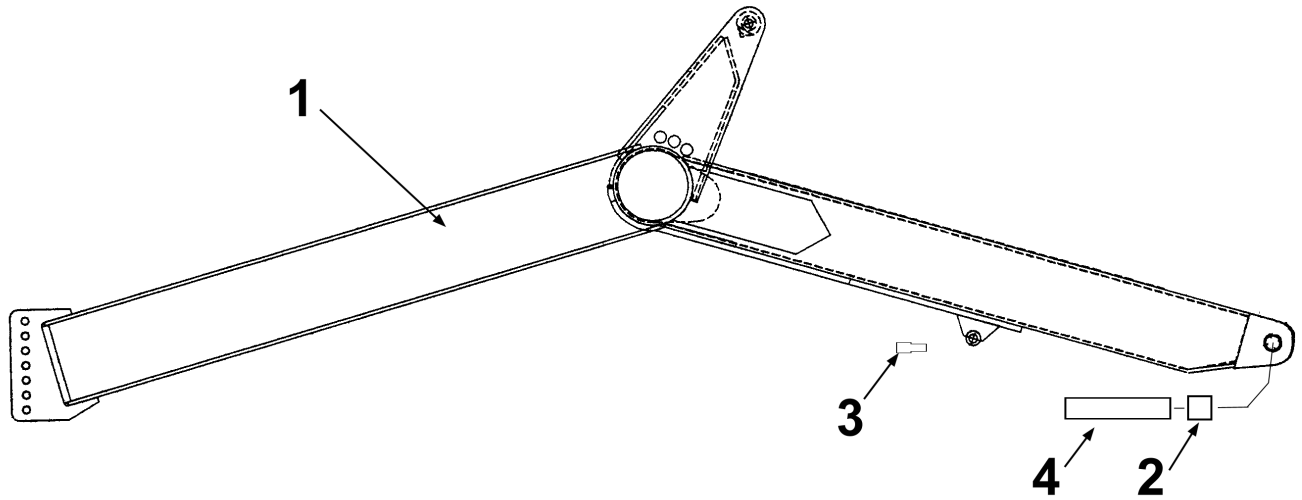

KEY NO.	PART NO.	DESCRIPTION
1.	A123297	Front End Assembly
2.	A14039	Bushing: 2.375 OD X 2.000 ID X 2" Long
3.	A17513	Transport Lock Pin: 1-1/8 X 5"
4.	A10152A	Pin, Frame Attachment, 2" OD x 8-1/16" Long

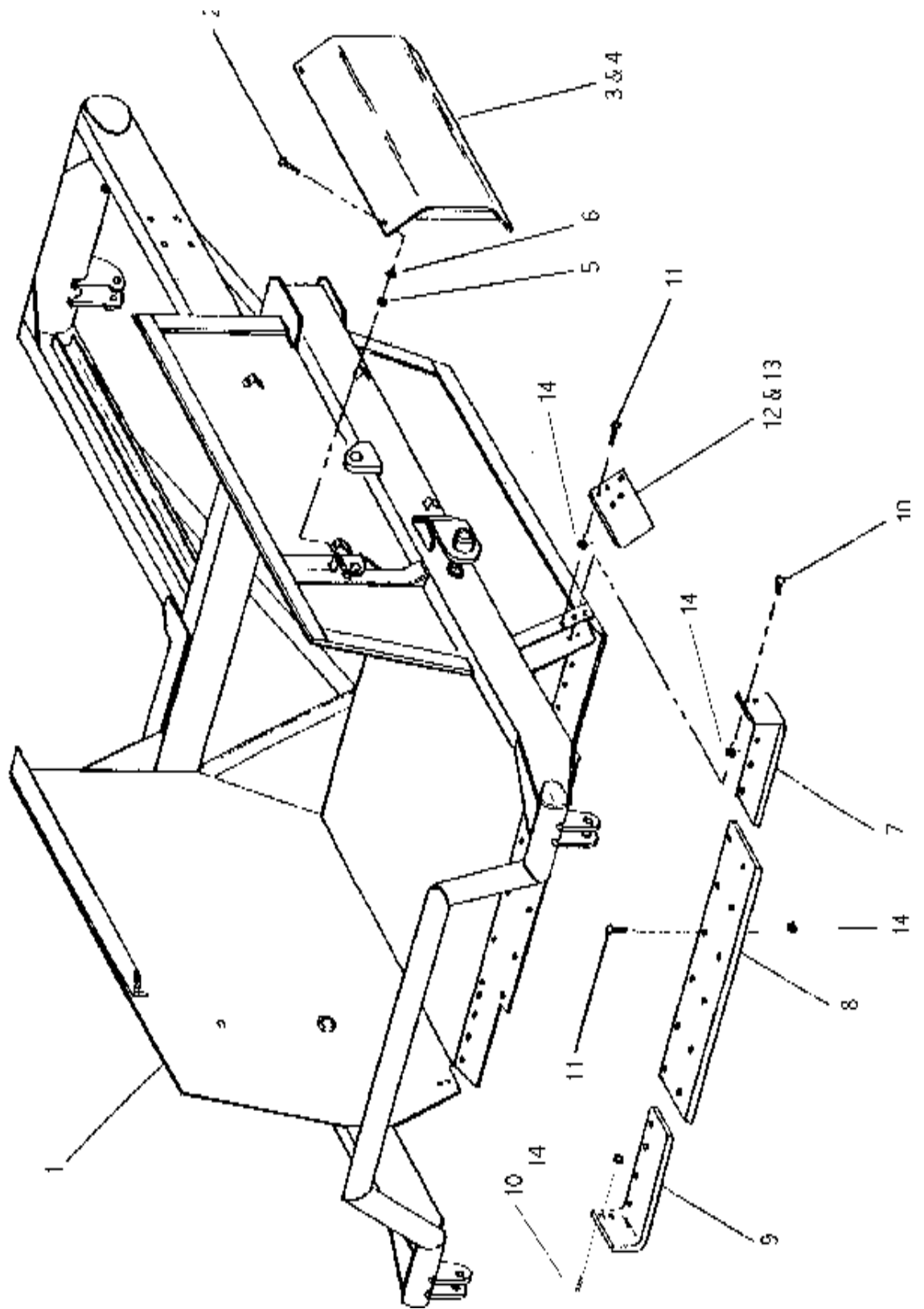

MODEL I-150 SP  
BOWL & FRAME ASSEMBLY

KEY NO.	PART NO.	DESCRIPTION
1.	A16026C	Bowl and Frame, Model I-150
2.	AFB-00034	Bolt: 3/8 NC X 1"
3.	A10157	Cylinder Guard - Left Hand
4.	A10158	Cylinder Guard - Right Hand
5.	7450	Nut: 3/8" NC
6.	8078	Lockwasher: 3/8"
7.	A10011A	Left Cutting Edge
10.	PB8P-NC-063-0200	Plow Bolt: 5/8 NC X 2" -> 6 Required
14.	7530	Nut: 5/8" NC -> 6 Required
8.	A14029C	Center Cutting Edge
11.	PB8P-NC-063-0250	Plow Bolt: 5/8 NC X 2-1/2" -> 12 Required
14.	7530	Nut: 5/8" NC -> 12 Required
9.	A10010A	Right Cutting Edge
10.	PB8P-NC-063-0200	Plow Bolt: 5/8 NC X 2" -> 6 Required
14.	7530	Nut: 5/8" NC -> 6 Required
12.	A14031A	Left Shaver Bit
11.	PB8P-NC-063-0250	Plow Bolt: 5/8 NC X 2-1/2" -> 7 Required
14.	7530	Nut: 5/8" NC -> 7 Required
15.	A14032A	Right Shaver Bit
11.	PB8P-NC-063-0250	Plow Bolt: 5/8 NC X 2-1/2" -> 7 Required
14.	7530	Nut: 5/8" NC -> 7 Required



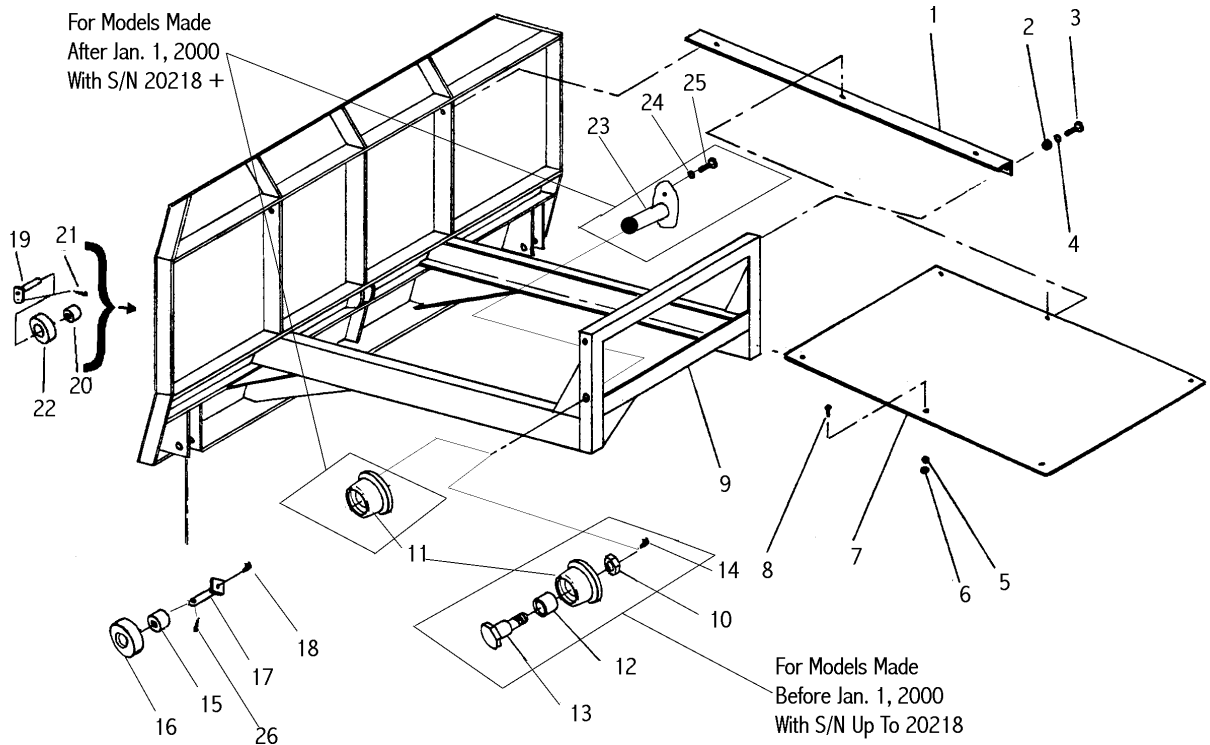

KEY NO.	PART NO.	DESCRIPTION
1.	A14022	Brace
2.	AFN-00006	Nut: 3/4" NC
3.	----	Bolt: 3/4" NC x 1-1/2" Lg.
4.	AFW-00002	Lockwasher: 3/4"
5.	8078	Lockwasher: 3/8"
6.	7450	Nut: 3/8" NC
7.	A14023	Dirt Shield
8.	AFB-00034	Bolt: 3/8 NC x 1" Lg.
9.	A16024	Pushoff Gate: Model I-150
10.	AFN-00024	Jam Nut: 1-1/4" NF
11.	A123306	Roller: Rear Gate
12.	A123307	Bushing" 1-5/8" OD x 1-1/4" ID
13.	A10008	Pin: Shoulder 1-5/8" to 1-1/4" Zerk in Thread
14.	14505	Grease Fitting: 1/8" NPT
15.	A10163	Bushing: 1-3/4" OD x 1-1/4" ID
16.	A10164	Roller: 4-1/4 OD X 1-3/4 ID
17.	A6007A	Pin: 1-1/4" x 4-1/8" Lg.
18.	AHF-00028	Grease Fitting: 1/8" NPT -90 degree
19.	A123288	Pin: 1-1/4 X 3-1/4" Tab Head
20.	A10163	Bushing: 1-3/4" OD x 1-1/4" ID
21.	7036	Bolt: 1/2 NC X 2"
22.	A10164	Roller: 4-1/4 OD X 1-3/4 ID
23.		Pin: 1-1/4 X 2-3/4"
24.	8100	Lockwasher: 1/2"
25.	AFB-00033	Bolt: 1/2 NC X 2-1/2"
26.	AFP-00001	Cotter Pin: 1/4 X 3-1/2"

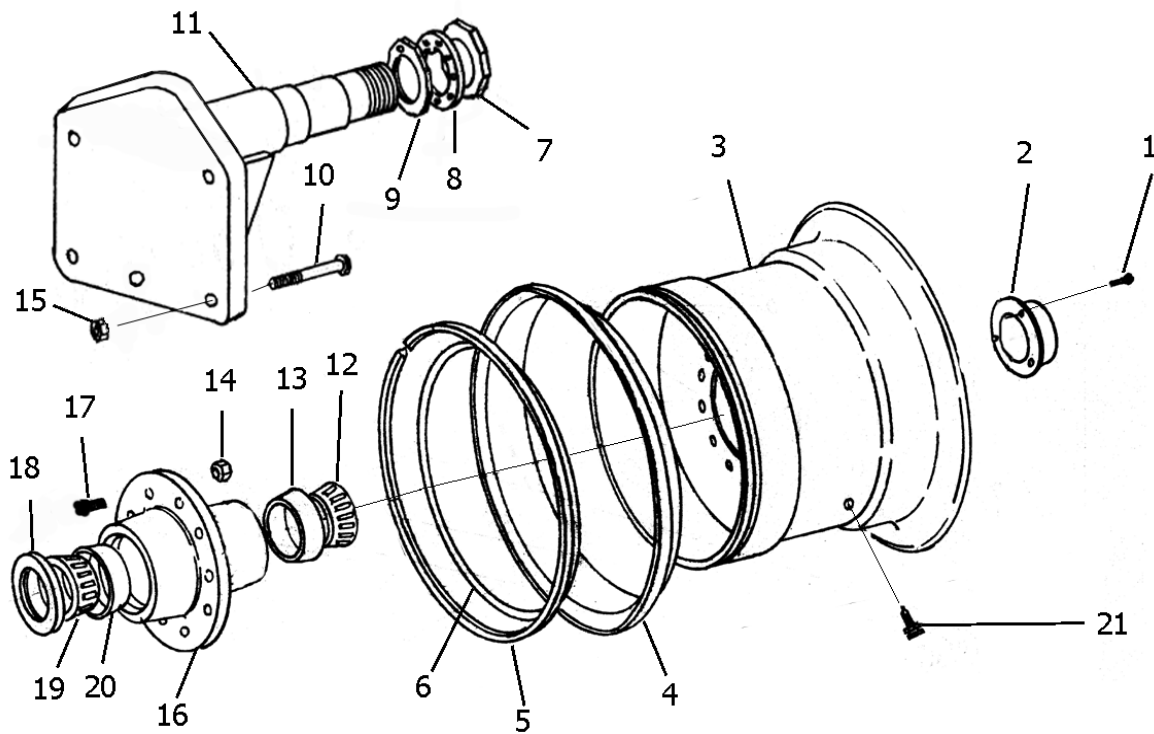

PARTS LIST  
 REAR WHEEL and HUB ASSEMBLY  
 MODEL I-150 SP

KEY NO.	PART NO.	DESCRIPTION
1.	AFB-00026	Bolt 5/16" NC X 5/8" Lg.
2.	A14004	Hub Cap
3.	A12036	Wheel Ass'y. 25" x 25"
4.	A12041	Side Ring
5.	A12042	Lock Ring
6.	A12047	O-Ring
7.	A10048	Spindle Nut
8.	A10049A	Lock Collar
9.	A10172	Nut with Lock Pin
10.	AFB-00017	Bolt 1" NF X 6-1/2" Lg.
11.	A12044	Spindle
12.	A14015	Bearing Cone ( Timken 644 )
13.	A14014	Bearing Cup ( Timken 632 )
14.	A12049	Lug Nut
15.	AFN-00001	Lock Nut: 1" NF
16.	A12035	Hub
17.	A12048	Lug
18.	A12037	Grease Seal ( National 416039 )
19.	A12038	Bearing Cone ( Timken 854 )
20.	A12039	Bearing Cup ( Timken 861 )
21.	A14016	Valve Stem

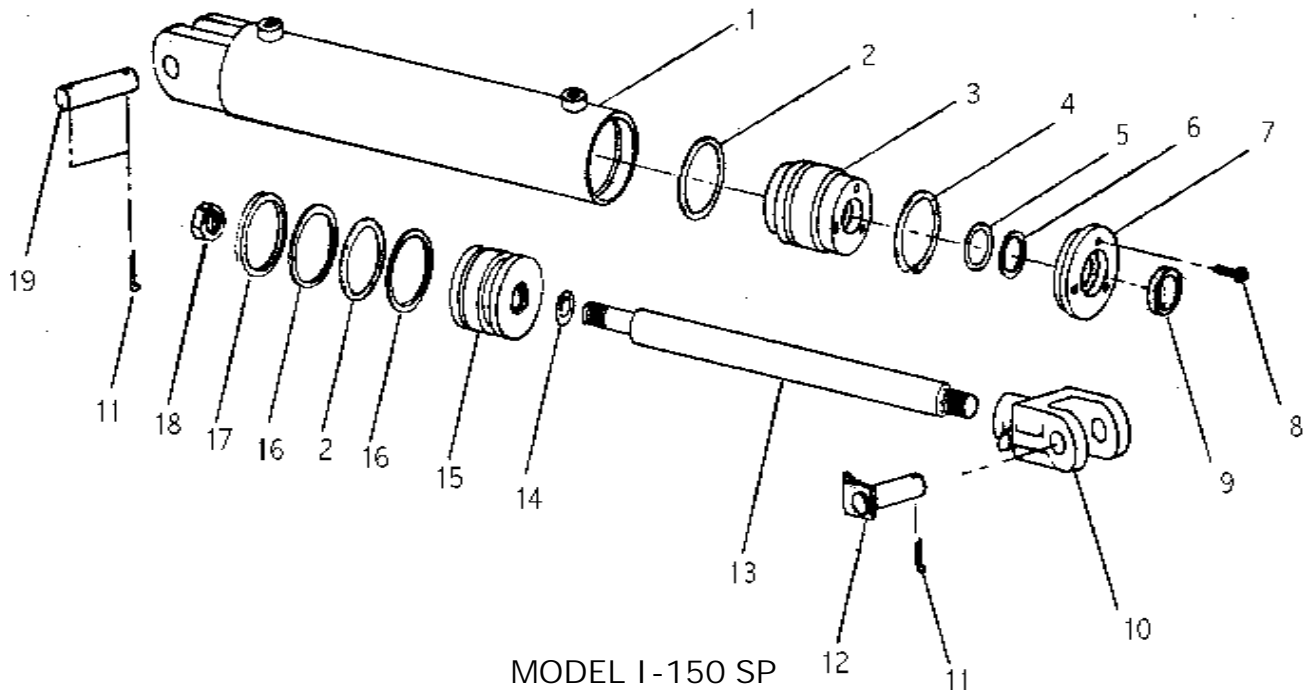

MODEL I-150 SP  
LEFT & RIGHT SIDE APRON CYLINDER 4 X 13  
PART NO. A413H1

KEY NO.	PART NO.	DESCRIPTION
1.	A175H013	Cylinder Barrel
2.	A300H06	O-Ring: 4" OD x 3/16"
3.	A300H11	Head Gland
4.	A300H12	Retainer Ring
5.	A22H15	O-Ring: 1-1/2" ID x 1/8"
6.	A22H15A	Backup Washer: 1-1/2"
7.	A300H13	Gland Cap
8.	A22H18	Capscrew: 1/4" NC x 1"
9.	A22H17	Wiper Seal: 1-1/2" ID
10.	A12H03	Clevis End
11.	-----	Cotter Pin: 3/16" x 1-1/2"
12.	A10167	Pin: Claw Head w/Grease Fitting 1" x 3-1/16"
13.	A175H02	Shaft: 1-1/2" Dia.
14.	A45H05	Piston Gasket: 1"
15.	A300H07	Piston: 4" Dia.
16.	A300H05	Backup Washer: 4" OD
17.	A300H04	Cast Iron Ring: 4" OD
18.	A300H03	Piston Nut, 1" NF
19.	A1217	Pin: 1" x 3-1/2"
	A300H14B	Packing Kit, Containing:
	(1) A300H04	(2) A22H15
	(2) A300H05	(1) A22H15A
	(2) A300H06	(1) A22H17
	(1) A45H05	

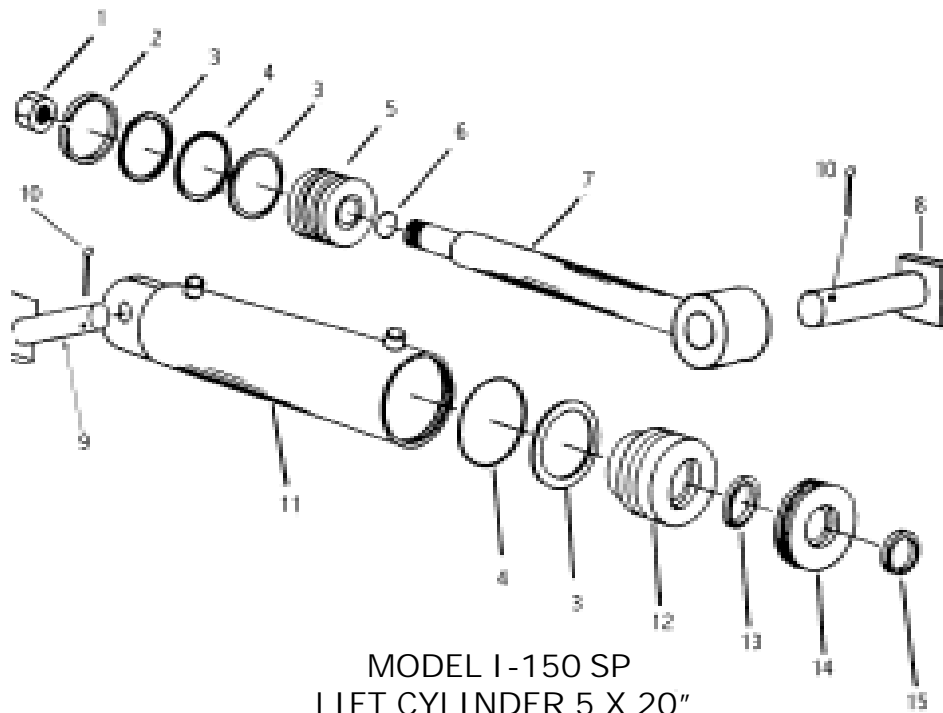

MODEL I-150 SP  
LIFT CYLINDER 5 X 20"  
PART NO. A520H118-114

KEY NO.	PART NO.	DESCRIPTION
1.	A400H17	Lock Nut: 1-1/4" NF
2.	A400H04	Cast Ring: 5" OD
3.	A400H05	Back-up Washer: 5" OD x 1/4"
4.	A400H06	O-Ring: 5" OD x 1/4"
5.	A80H01	Piston: 5" O.D.
6.	A60H52	O-Ring: 1-1/4" OD x 1/16"
7.	A80H08A	Shaft: 2" Dia.
8.	A	Pin: 2 X 9-7/16" w/Tab Head
9.	A	Pin: 2 X 5-1/4 w/Tab Head"
10.	AFP-00001	Cotter Pin: 1/4 X 3-1/2"
11.	A80H02	Barrel Assembly: 5" ID
12.*	A80H03	Head Gland: 5" OD
13.	A80H04	Seal: 2" ID
14.*	A80H05	Head Cap
15.	A80H06	Wiper Seal 2" ID
*16.	A80H05A	One Piece Gland & Cap
	A80H07	Packing Kit, Containing:
	(1) A400H04	(1) A60H52
	(3) A400H05	(1) A80H04
	(2) A400H06	(1) A80H06

MODEL I-150 SP  
PUSHOFF CYLINDER 5 X 60"  
PART NO. A560H114A

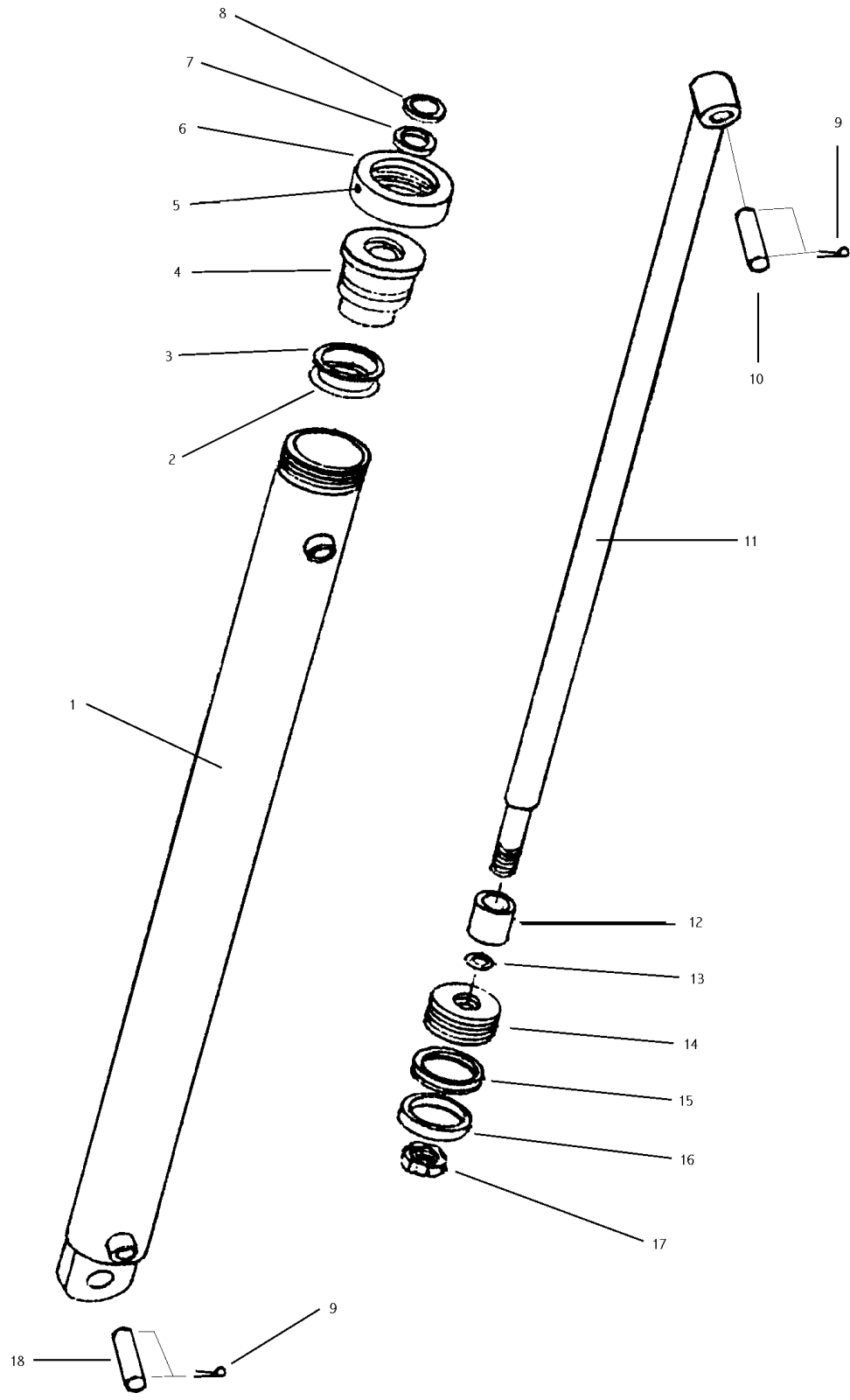

MODEL I-150 SP  
 PUSHOFF CYLINDER 5 X 60"  
 PART NO. A560H114A

KEY NO.	PART NO.	DESCRIPTION
1.	A140H20	Barrel Assembly: 5" Bore
2.	A400H06	O-Ring: 5" OD X 4-1/2" ID
3.	A400H05	Back Up Washer: 5" OD X 4-1/2" ID
4.	A140H21	Head Gland: 5"
5.	-----	Set Screw: 3/8" NC
6.	A140H19	Collar
7.	A140H07	Shaft Seal: 2-1/2" ID X 3" OD OU-Cup
8.	A140H08	Wiper Seal: 2-1/2" ID X 2-15/16" OD
9.	8602	Cotter Pin: 1/4" X 2"
10.	A14033	Pin: 1-1/4" Dia. X 5" Lg.
11.	A140H27	Shaft: 2-1/2" Dia.
12.	A175H06	Spacer
13.	A22H15	O-Ring: 1-1/2" x 1-3/4" OD
14.	A140H22	Piston: 5"
15.	A140H24	Piston Seal: 5" OD X 4-1/4" ID
16.	A140H25	Wear Ring: 5" OD
17.	AFN-00018	Lock Nut: 1-1/2" NF
	A140H28	Packing Kit: Containing: (1) A140H25      (1) A400H06 (1) A140H07      (1) A140H08 (1) A22H15      (1) A400H05 (1) A140H24
18.	A9024	Pin: 1-1/4 X 4-3/4"

# MAINTENANCE CHECKLIST

---

1. Grease all zerks.
  - a) Every 8 hours of operation.
  - b) See Lubrication Points section on page 3.
  
2. Greasing the hubs.
  - a) Re-pack wheel bearings after 600 hrs of operation.
  - b) Completely clean grease out of hub and bearings every 1200 hours of operation.
  
3. Check tire pressure.
  - a) 29.5 – 25, 28-ply tire requires a tire pressure of 45-50 psi.  
If pressure drops, first secure valve stem, and if pressure continues to drop, contact Ashland Industries.
  
4. Check all pins for signs of wear.
  - a) Daily
  
5. Check wheel lug nut torque.
  - a) After first 2 hours of operation.
  - b) Recheck daily for next 2 weeks.
  - c) Tighten wheel lug nuts in a star pattern.
  - d) Torque wheel lug nuts to 750 ft-lbs.
  
6. Check and retighten all bolts.
  - a) After initial 10 hours of use.
  - b) Again after 50 hours of use.
  - c) See Torque Specifications on page 3.
  
7. Inspect cutting edges.
  - a) Daily
  - b) Replace cutting edges when center blade has been worn to approximately 6" and side edges worn to approximately 4".



**AUTION!** Failure to replace worn cutting edges may result in unnecessary wear to the earthmover sides and floor.

---

Note: Please specify left or right "L" shaped cutting edges when ordering replacements.

# TORQUE SPECIFICATIONS

---

<i>Grade 8</i>	
<i>Bolt</i>	<i>Torque</i>
<i>Diameter</i>	<i>ft-lbs</i>
1/4"	12
5/16"	25
3/8"	45
7/16"	70
1/2"	110
9/16"	150
5/8"	220
3/4"	380
7/8"	600
1"	900
1-1/8"	1280
Lug Nuts	750

## LUBRICATION

---

1. Grease all zerks every 8 hrs of operation with high quality, general-purpose grease.
  - a) Grease until grease flows from around pin.

Lubrication Points (*see Ill. on next page*)

1. Hitch – Horizontal and vertical pins.
2. Lift Cylinders – Rod end & base end; Both left & right sides.
3. Front Arm Pivot Joint – Both left & right sides.
4. Apron Cylinders – Rod clevis pin; Both left & right sides.
5. Apron Pivot Pin – Both left & right sides.
6. Hold-down Rollers – Both left & right sides.
7. Floor Rollers – Both left & right sides.
8. Tapered Rollers – Both left & right sides.



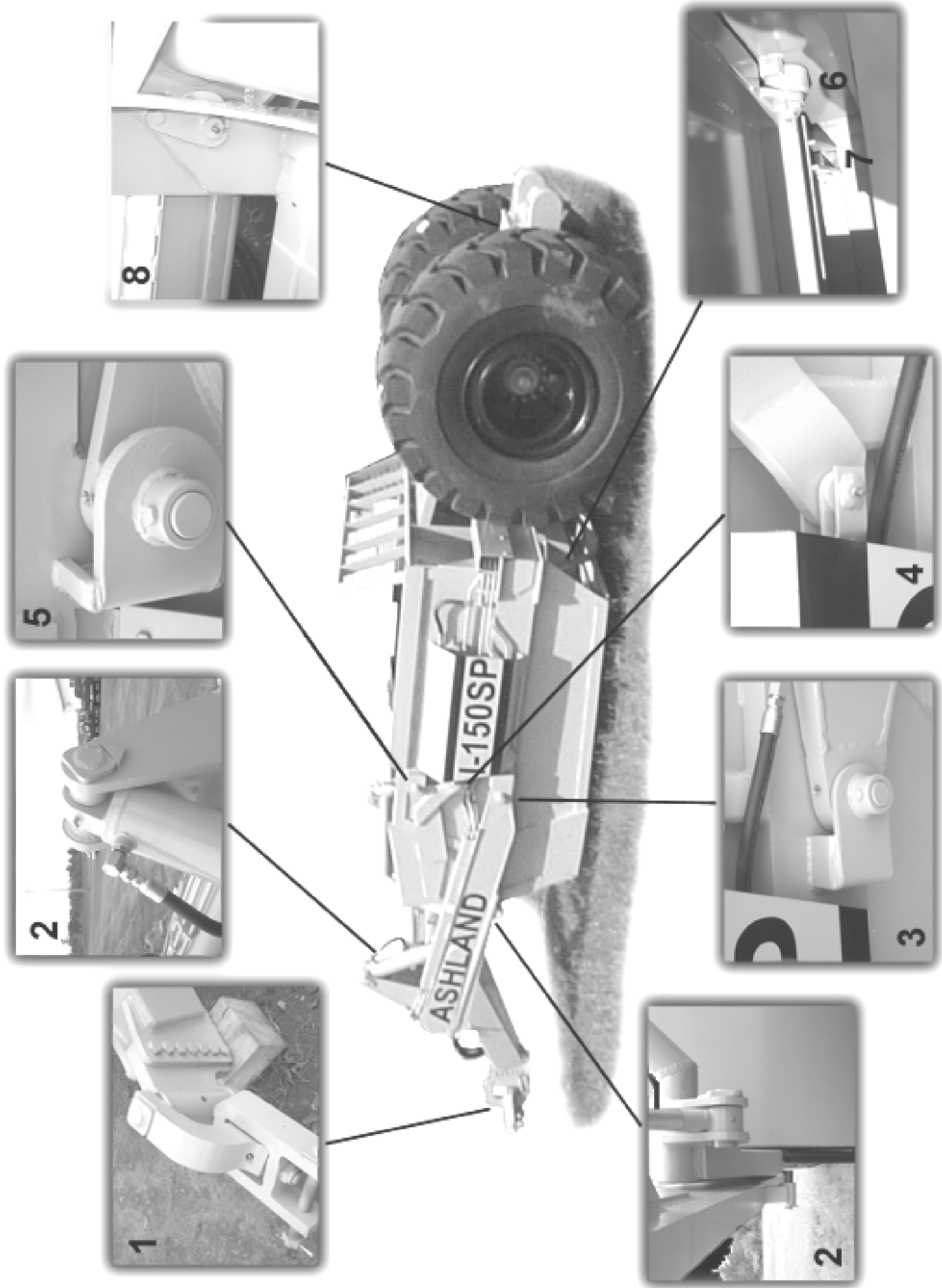

# HYDRAULIC SYSTEM

---

## Standard Two-Circuit Hydraulic Plumbing

The apron cylinders and the push-off cylinder are controlled on the same circuit with the sequence of the operation controlled by a sequence valve. The other hydraulic circuit controls the lift cylinders on the earthmover.

\*To adjust the sequence valve, see Troubleshooting section.

## Optional Three-Circuit Hydraulic Plumbing

The apron cylinders, push-off cylinder, and lift cylinders are all on separate hydraulic circuits.

## Push-off Cylinder Hydraulic System

A pressure relief valve, in both two-circuit and three-circuit hydraulic plumbing, protects the pushoff cylinder hydraulic system. This pressure relief valve is designed to limit the hydraulic oil pressure delivered to the push-off cylinder. This valve is preset from the factory at 2000 psi.

\*To adjust the pressure relief valve, see Troubleshooting section.



CAUTION! Relieve all hydraulic pressure before working on the hydraulic system.

---

---

---

**WARNING!** High Pressure Fluid Hazard – To prevent serious injury or death from high pressure fluid:

- a) Relieve pressure on hydraulic system before repairing, adjusting, or disconnecting.
- b) Wear proper hand and eye protection when searching for leaks.
- c) Keep all components in good repair.

---

## PUSHING THE EARTHMOVER

---

The I-150SP was designed to be pushed when equipped with the optional push-bar. However, Ashland Industries, Inc. *STRONGLY* recommends using extreme caution when pushing the I-150SP earthmover to prevent any unnecessary damage.



CAUTION! The I-150SP earthmover must be pushed in a straight line with a maximum of a 150 hp dozer. Do not ram or jar the earthmover while pushing and push at a constant speed.

---



# TROUBLESHOOTING

---

---

## Introduction

---

With proper care and maintenance, the I-150SP will give many years of reliable service. When a situation arises where the earthmover performance is not satisfactory, this section will give some pointers on finding and correcting the problem.

---

### Grease zerk will not take grease.

---

1. Grease zerk plugged.
  - a) Remove and replace grease zerk.
2. Pin is frozen.
  - a) Remove, clean, and inspect pin.
  - b) Replace pin if necessary.
3. Bushing grease passage is not aligned with grease zerk.
  - a) Remove, clean, inspect, and realign bushing.
  - b) Replace bushing if necessary and realign.

---

### Push-off rollers do not roll.

---

1. The rollers need lubrication.
  - a) Check zerk hole and grease.
  - b) Remove pin, clean, inspect, and replace if necessary.
2. The roller bushing is worn out.
  - a) Remove roller assembly and replace bushing.
  - b) See parts manual.

---

### Cylinders will not hold in preset position, i.e. the cylinder creeps.

---

1. Seals leaking internally.
  - a) Remove and replace seal kit.

---

## Machine cuts unevenly.

---

1. Cutting edges worn unevenly.
  - a) Replace cutting edges.
2. Improperly inflated tires.
  - a) Check air pressure in tires.

---

## Push-off cylinder stalls during ejection process.

---

1. Adjust pressure relief valve bypass pressure.
  - a) Remove the acorn nut from the end of the pressure relief valve with a  $\frac{1}{2}$ " wrench to expose the adjustment screw. Turn the adjustment screw, using a 4mm hex wrench, clockwise to increase pressure and counter-clockwise to decrease pressure. Use a pressure gauge in the hydraulic line as shown, to set the pressure.

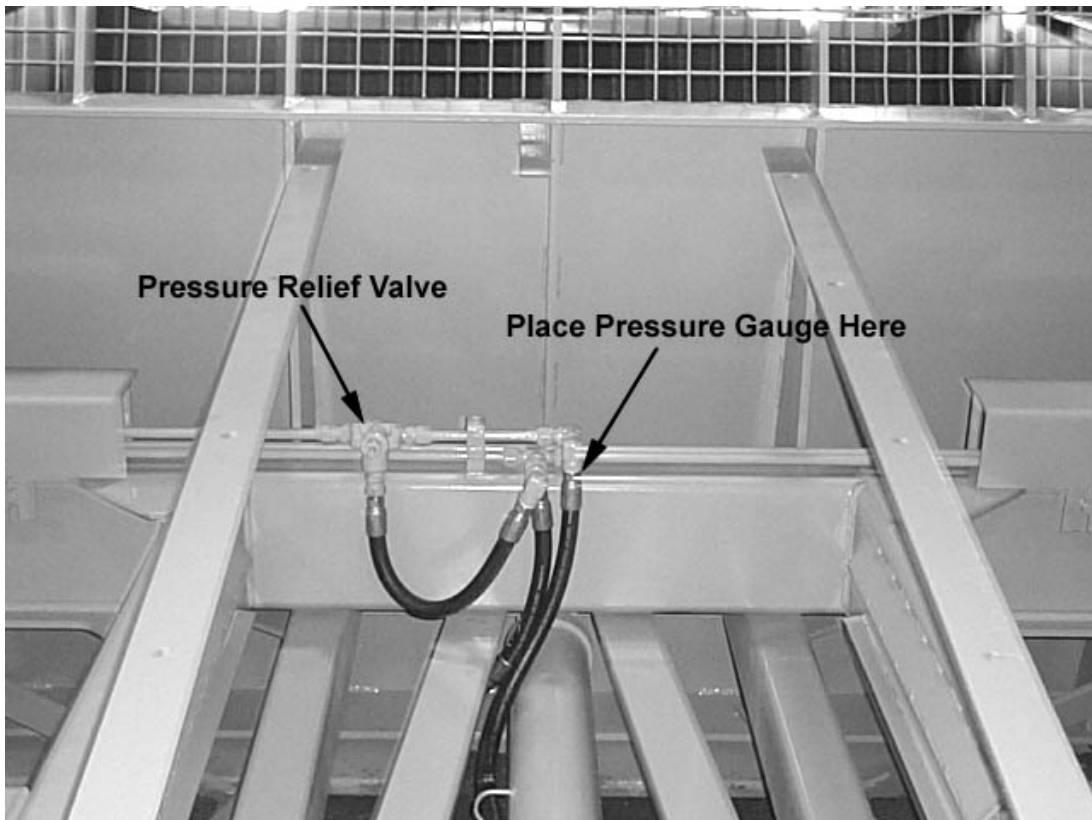

---

Apron closes slowly

or

Apron and push-off are not working well together.

---

1. Sequence valve needs adjusting.

a) Remove acorn nut from end of sequence valve with a ½" wrench. Turn adjustment screw, using a 4mm hex wrench, clockwise until front apron rises before the push-off advances while the earthmover is empty. Turn the adjustment screw an additional ¼ turn clockwise, then replace the acorn nut and tighten.

b) Torque check valve assembly and int. pilot plug to 25 ft-lbs maximum.



**CAUTION!** Overtightening check valve assembly and int. pilot plug will cause internal damage to the sequence valve.

---

\* Note: Check valve assembly may leak slightly when torqued to 25 ft-lbs.

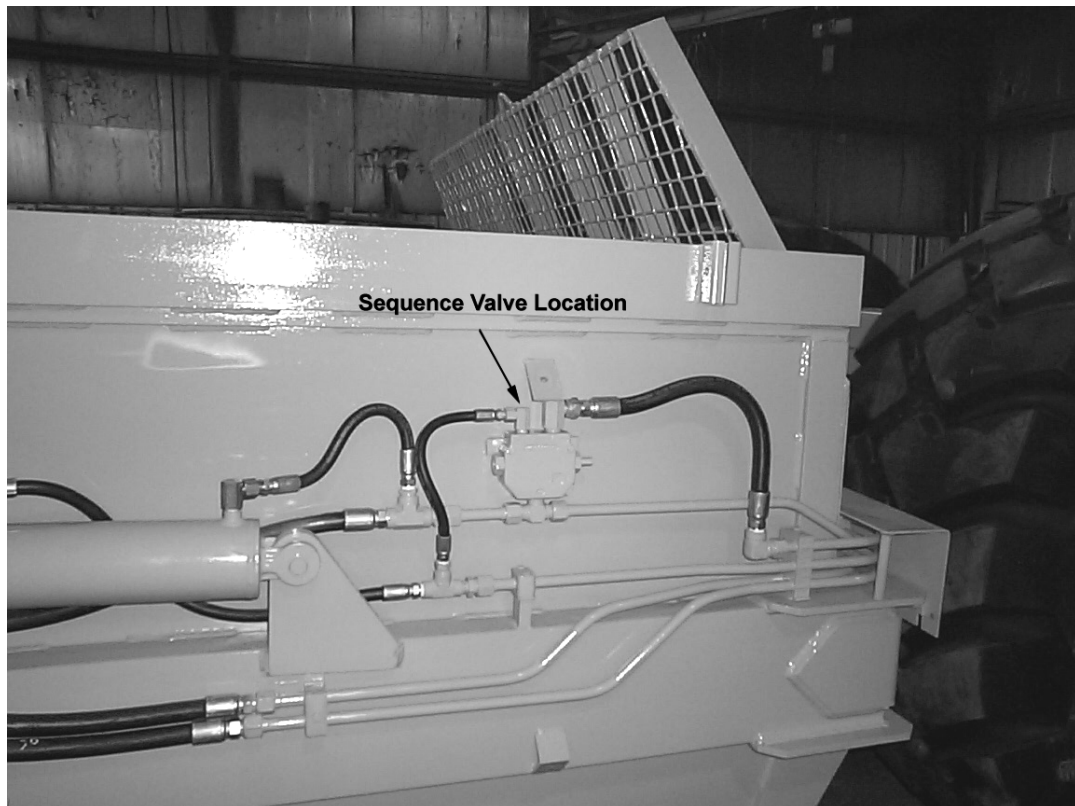

# Limited Warranty Statement

Ashland Industries Inc. warrants each new product to be free from defects in material and workmanship. This warranty is applicable only for the normal service life expectancy of the product or components, not to exceed six consecutive months from the date of delivery of the new Ashland Industries product to the original purchaser, or the date the product is first put into service via a rental agreement or other means, whichever occurs first.

Genuine Ashland Industries Inc. replacement parts and components will be warranted for 30 days from date of purchase, or the remainder of the original equipment warranty period, whichever is longer.

Under no circumstances will it cover any merchandise or components thereof, which in the opinion of the company, has been subjected to misuse, unauthorized modification, alterations, an accident or if repairs have been made with parts other than those obtained through Ashland Industries Inc.

Ashland Industries Inc. in no way warrants Tires since these items are warranted separately by their respective manufacturer. Please call Ashland Industries Inc. to receive phone numbers of tire suppliers.

Ashland Industries Inc. in no way warrants wearable items such as cutting edges, front dolly wheel balls, socket halves.

Our obligation under this warranty shall be limited to repairing or replacing, free of charge to the original purchaser, any part that, in our judgement, shall show evidence of such defect, provided further that such part shall be returned within 30 days from the date of failure to Ashland Industries Inc. routed through the dealer and distributor from whom the purchase was made, transportation charges prepaid. Upon warranty approval proper credits will be reimbursed for transportation.

This warranty shall not be interpreted to render Ashland Industries Inc. liable for injury or damages of any kind or nature to person or property. This warranty does not extend to the loss revenue, extra labor cost associated with downtime, substitute machinery, rental or for any other reason.

Except as set forth above, Ashland Industries Inc. shall have no obligation or liability of any kind on account of any of its equipment and shall not be liable for special or consequential damages. Ashland Industries Inc. make no other warranty, expressed or implied, and, specifically, Ashland Industries Inc. disclaims any implied warrant or merchantability or fitness for a particular purpose. Some states or provinces do not permit limitations or exclusions of implied warranties or incidental or consequential damages, so the limitations or exclusion in this warranty may not apply.

This warranty is subject to any existing conditions of supply which may direct affect our ability to obtain materials or manufacture replacement parts.

Ashland Industries Inc. reserves the right to make improvements in design or changes in specifications at any time, without incurring any obligation to owners of units previously sold

No one is authorized to alter, Modify or enlarge this warranty nor the exclusion, limitations and reservations.