



Quality Equipment since 1953

I-140

PARTS MANUAL



Hwy. 13 South
P.O. Box 717
Ashland, WI. 54806
715-682-4622
715-682-9717
www.ashlandind.com





ASSEMBLY INSTRUCTIONS

MODEL I-140 SCRAPER

1. A suitable hoist should be available for assembly.
2. Install 20.5 x 25 rim mounted tires to rear hubs.
3. Install gooseneck frame to bowl and frame assembly with two A10152 shoulder pins and 2 inch NF nuts.
4. Install 15.5 x 25 rim mounted tires to pole and axle assembly.
5. Raise the front frame and remove the two 3/4" x 4-1/2" bolts which hold the cast socket halves inside the gooseneck post and remove the socket halves.
6. Roll the pole and axle under the gooseneck and place the cast socket halves around the ball swivel on the axle, with the socket half with the threaded hole towards the front. Lower the frame into place so that the socket halves seat into the gooseneck. (If necessary, clamp halves together with a C-clamp while lowering the gooseneck.) Replace the two 3/4" x 4-1/2" bolts and tighten securely install A2206 long shank grease fitting into the threaded hole.
7. Raise the bowl by the front cross member tube, high enough to install two A10153 transport lock pins with the hair pin clips. Lower the bowl until the ears rest on the lock pins.
8. Install apron to bowl with two 1-1/2" x 6" NF grade 8 bolts and two 1-1/2" NF self lock nuts.
9. Connect apron cylinders to apron arms with a A10167 pin and cotter pin.
10. Install lift cylinders, bases connected to gooseneck frame with A14034 pins and 1/4" x 2" bolts. Install rod end of lift cylinders to bowl frame with A14033 pins and 1/4" x 2" bolts.
11. Install four 3/4" bulkhead unions thru bulkhead plate with lock nuts on the front side of the plate. Connect two A101H32, 3/4" x 21" long hoses to the two 3/4" elbows on top of the front crossmember and to the two bottom bulkhead unions. (These two lines are to be connected to the same spool on the control valve on the tractor.) Refer to Pages 16 and 17 in the parts manual.
12. Connect two 3/4" x 25-1/2" hose to the two 3/4" inch tees on the front crossmember and to the two top bulkhead unions. (These two lines are to be connected to the spool on the control valve on the tractor.

13. Connect two A45H06 1/2" x 24" hoses to the two lift cylinder bases. Connect two A140H16 1/2" x 33" hoses from the cylinder rod ends to the two most rearward 1/2" elbows on front crossmember which is one common line. Connect the two hoses from the cylinder base ends to the two remaining 1/2" elbows which is also on common line.
14. Remove the dirt shield from the left side of the scraper and remove and discard the hex plug installed in the 3/4" elbow. Connect one end of the A101H42 3/4" straight adapter on the front frame. Reinstall dirt shield.
15. Remove and discard the hex plug from the 3/4" elbow located on right side of the scraper behind the apron cylinder. Connect one end of the A101H36 3/4" x 33" long straight adapter on the front frame. Install the dirt shield.

Care should be taken to make sure all plastic plugs are removed from all hoses and fittings and no dirt is allowed into the hydraulic circuit.



HOW TO ORDER PARTS:

IMPORTANT

Be sure to state Model and Serial Number of your machine, part number, description and quantity needed.

Unless this is done, we cannot provide prompt service or assure shipment of correct parts.

INDEX

Page 1.	Illustration - Assembly
Page 2.	Operators and Maintenance Instructions
Page 3.	Illustration - Gooseneck Frame Assembly
Page 4.	Illustration - Apron Assembly
Page 5.	Illustration - Bowl and Frame Assembly
Page 6.	Parts List - Bowl and Frame
Page 7.	Illustration and Parts List - Push Off Gate Assembly
Page 8.	Illustration and Parts List - Front Wheel and Hub Assembly
Page 9.	Illustration and Parts List - Rear Wheel and Hub Assembly
Page 10.	Illustration and Parts List - Hydraulic Cylinder 4" x 13"
Page 11.	Illustration and Parts List - Hydraulic Cylinder 4" x 13"
Page 12.	Illustration and Parts List - Hydraulic Cylinder 5" x 20"
Page 13.	Illustration - Hydraulic Cylinder 4-1/2" x 60"
Page 14.	Parts List - Hydraulic Cylinder 4-1/2" x 60"
Page 15.	Illustration - Hydraulic Circuit
Page 16.	Parts List - Hydraulic Circuit

ILLUSTRATION * ASSEMBLY

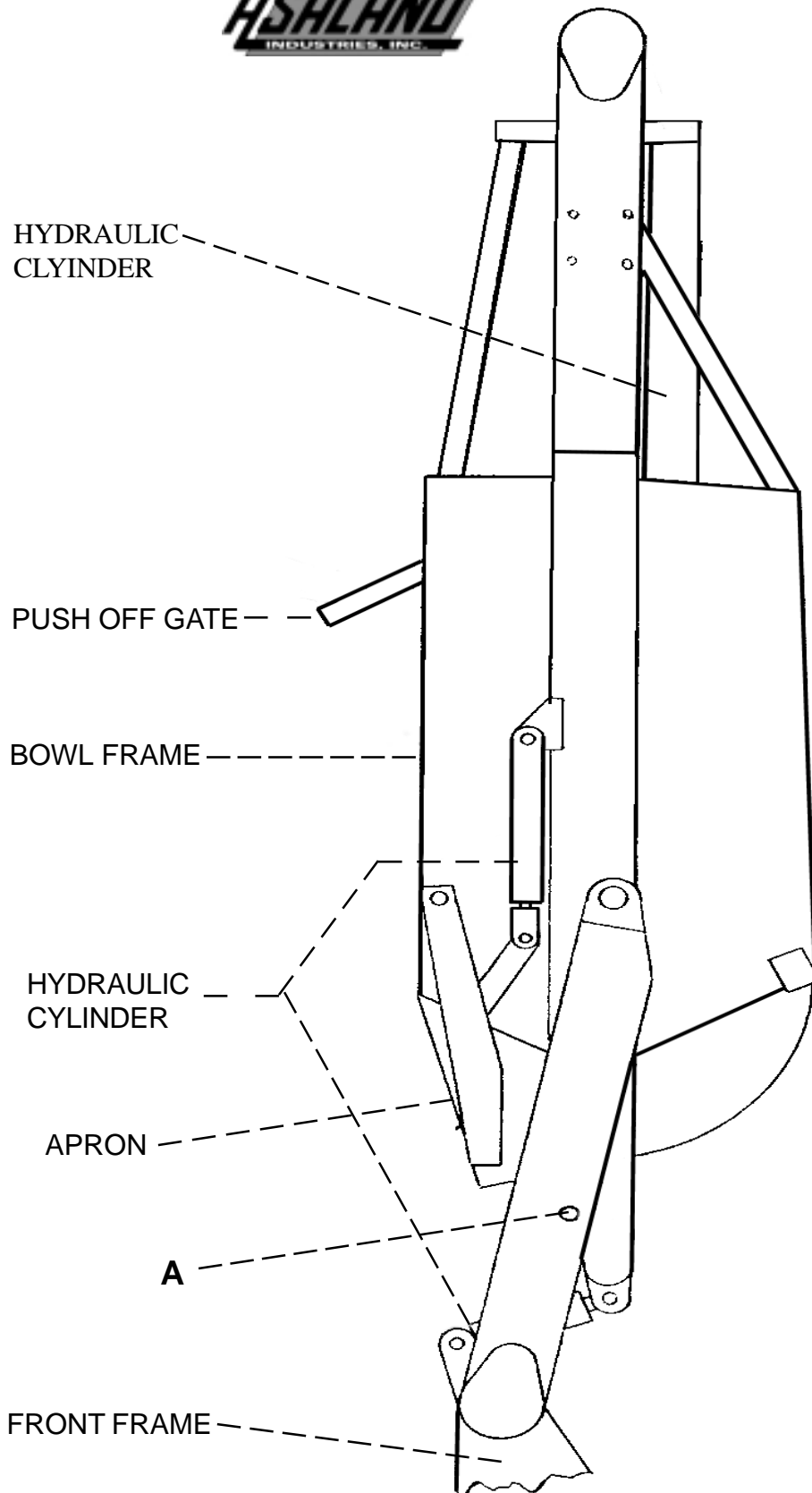

OPERATORS AND MAINTENANCE INSTRUCTIONS

The scraper is a durable piece of equipment and with proper care will yield many years of trouble free operation. The scraper requires a power source with TWO 4 way (double acting) hydraulic control valves.

The scraper should be greased at all points where grease fittings are provided. Connect hydraulic hoses to the tractor and retract lift cylinders to remove transport lock pins (point A), then extend and retract all cylinders several times to force out any air from the hydraulic cylinders and lines. Check the oil levels in the tractor hydraulic system and add to maintain the proper level. Care should be used when adding oil or when disconnecting any oil line to keep all dirt out of the oil as dirt is a major factor in the failure of hydraulic components.

When the scraper is placed into operation the operation to the operator will have to “feel out” the amount of depth of cut to obtain maximum loading efficiency. This is usually accomplished by taking a lesser and more uniform cut. However, some soil conditions such as loose sand may require a “pumping action” obtained by taking successive deep cuts and lifting out of cut as the tractor begins to lose power or traction.

1. After 10 hours work, all bolts should be checked and tightened if necessary.
2. Every 10 hours all grease fittings should be lubricated.
3. After 50 hours work, all bolts should be rechecked and tightened if necessary. Check wheel bearings and adjust if necessary.
4. After 300 hours work, clean and repack wheel bearings and replace, if necessary, cutting edges, worn pins, etc.



GOOSENECK FRAME ASSEMBLY

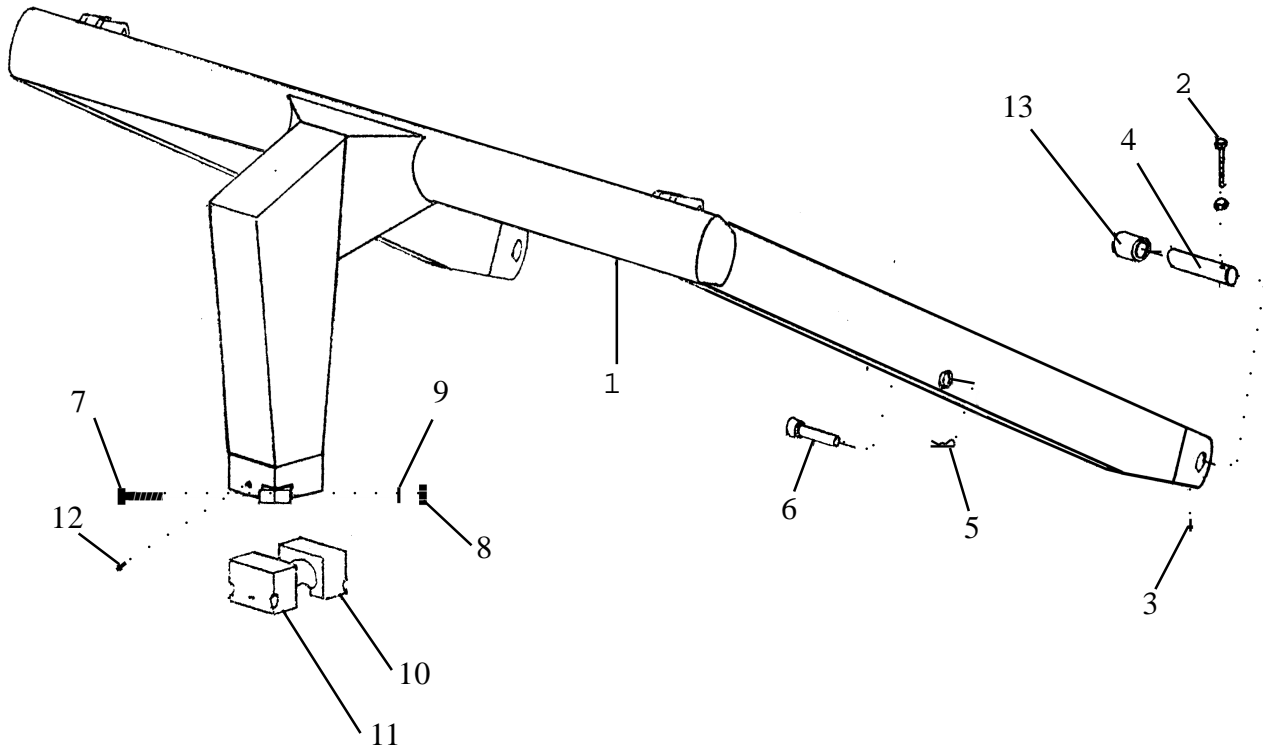

PARTS LIST GOOSENECK FRAME ASSEMBLY MODEL I-140

Page 2

KEY NO.	PART NO.	DESCRIPTION
1.	A14001B	Gooseneck Frame for serial number 17815 and up
2.	----	Bolt, 1/2" NC x 3-1/2" Lg.
3.	----	Grease Zerk - Straight
4.	A10152A	Pin, Frame Attach
5.	----	Hair Pin
6.	A10153	Pin, Transport Lock
7.	----	Bolt, 7/8"NF x 5" Lg. Grade 8
8.	----	Nut, 7/8"NF
9.	----	Lockwasher 3/4"
10.	A14002	Cast Socket Half - Rear
11.	A14003	Cast Socket Half - Front w/Zerk Hole
12.	A2206	Grease Zerk - Long Shank
13.	A14039	Bushing, 2-3/8" OD x 2" Long

APRON ASSEMBLY

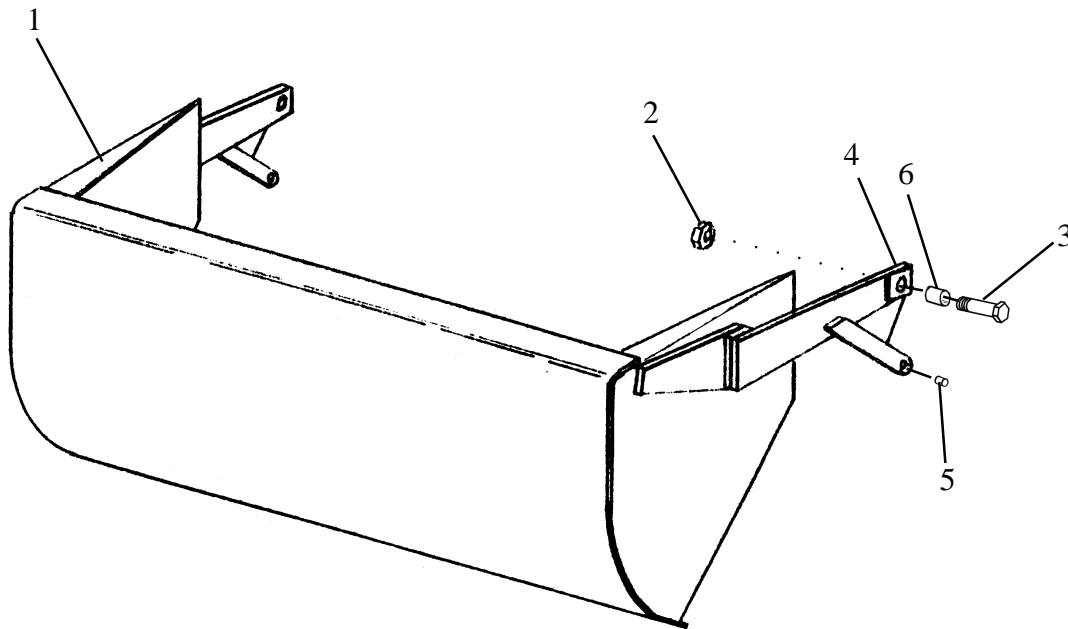

PARTS LIST APRON ASSEMBLY MODEL I-140

<u>KEY NO.</u>	<u>PART NO.</u>	<u>DESCRIPTION</u>
1.	A14025A	Apron Model I-140
	A16025A	Apron Model I-160, s/n 17332 to 17581
	A16025B	Apron Model I-160, s/n 17642 to 17697
	A16025C	Apron Model I-160, s/n 17698 and up
2.	-----	Self Lock Nut, 1-1/4" NF
	-----	Self Lock Nut, 1-1/2" NF
3.	A6010	Shoulder Pin, 1-5/8" x 1-1/4", up to s/n. 17130
	A17506	Shoulder Pin, 2-1/4" x 1-1/4", s/n 17332 to 17581
	A17506A	Shoulder Pin, 2-1/4" x 1-1/2", s/n 17642 to 17697
	-----	Bolt, 1-1/2" NF x 6" Lg., for s/n 17698 and above
4.	-----	Grease Fitting, 1/8" NPT
5.	A10155	Bushing, 1-1/2" OD x 1" ID x 1" Lg.
6.	A16027	Bushing, 2" OD x 1-1/2" ID x 2" Lg. for s/n 17698 and above

BOWL and FRAME ASSEMBLY

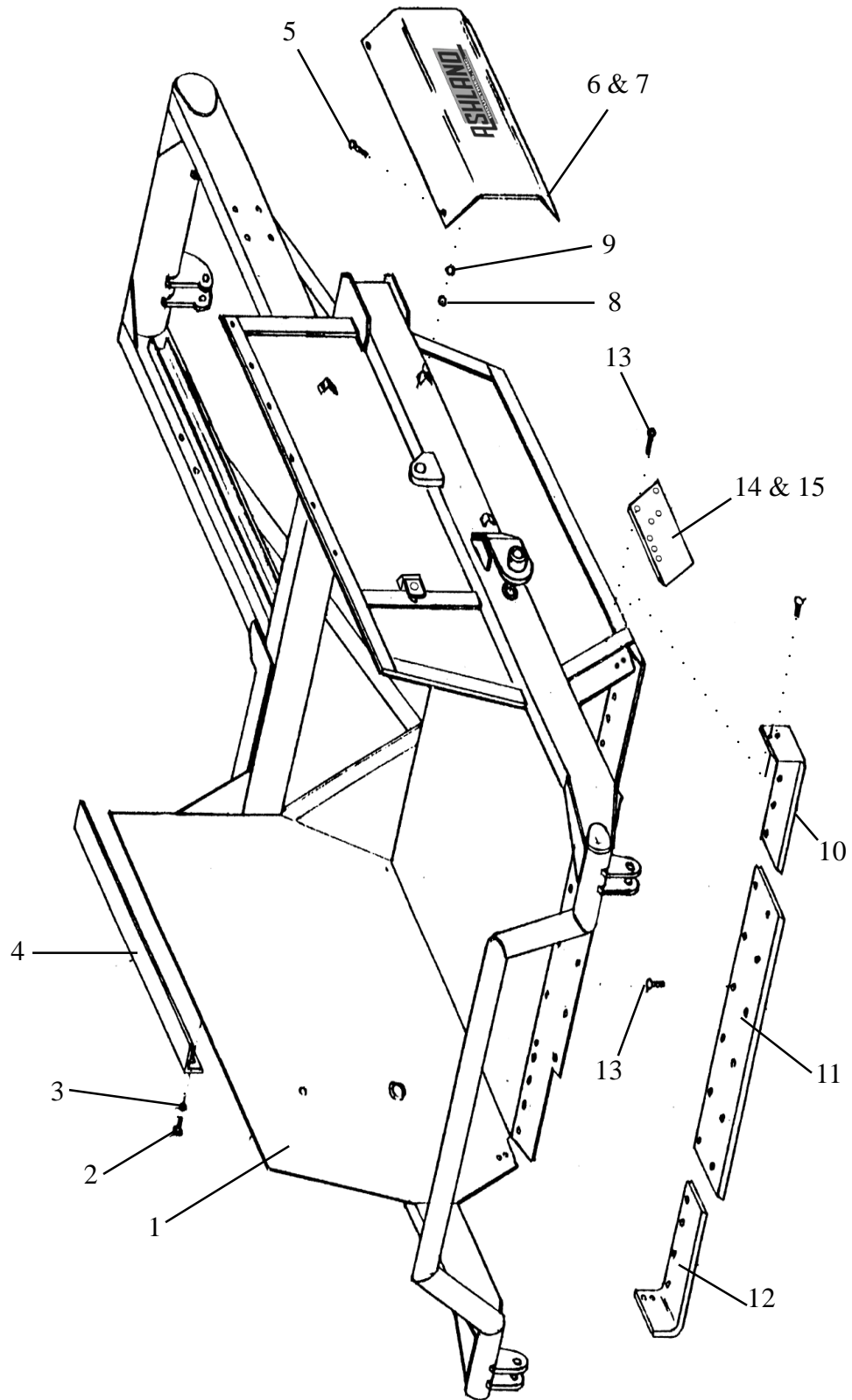

PARTS LIST
BOWL and FRAME ASSEMBLY

MODEL I-140 SCRAPER

<u>KEY NO.</u>	<u>PART NO.</u>	<u>DESCRIPTION</u>
1.	A14026	Bowl and Frame, Model I-140
	A16026A	Bowl and Frame, Model I-160 - serial number 17332 to 17581
	A16026B	Bowl and Frame, Model I-160 - serial number 17642 to 17697
	A16026C	Bowl and Frame, Model I-160 - serial number 17698 and up
2.	-----	Capscrew 5/8"NC x 1-1/4" Lg.
3.	-----	Lockwasher 1/2"
4.	A17504	Gate Containment Angle
5.	-----	Bolt 3/8"NC x 1" Lg.
6.	A10157	Cylinder Guard - Left Hand
7.	A10158	Cylinder Guard - Right Hand
8.	-----	Nut 3/8" NC
9.	-----	Lockwasher 3/8"
10.	A10011A	Left Cutting Edge
11.	A14029	Center Cutting Edge
12.	A10010A	Right Cutting Edge
13.	-----	Plow Bolt 5/8"NC x 2-1/2" Lg.
14.	A14031	Left Shaver Bit - serial number up to 17581
	A14031A	Left Shaver Bit - serial number 17642 and up
15.	A14032	Right Shaver Bit - serial number up to 17581
	A14032A	Right Shaver Bit - serial number 17642 and up

PUSH OFF GATE ASSEMBLY

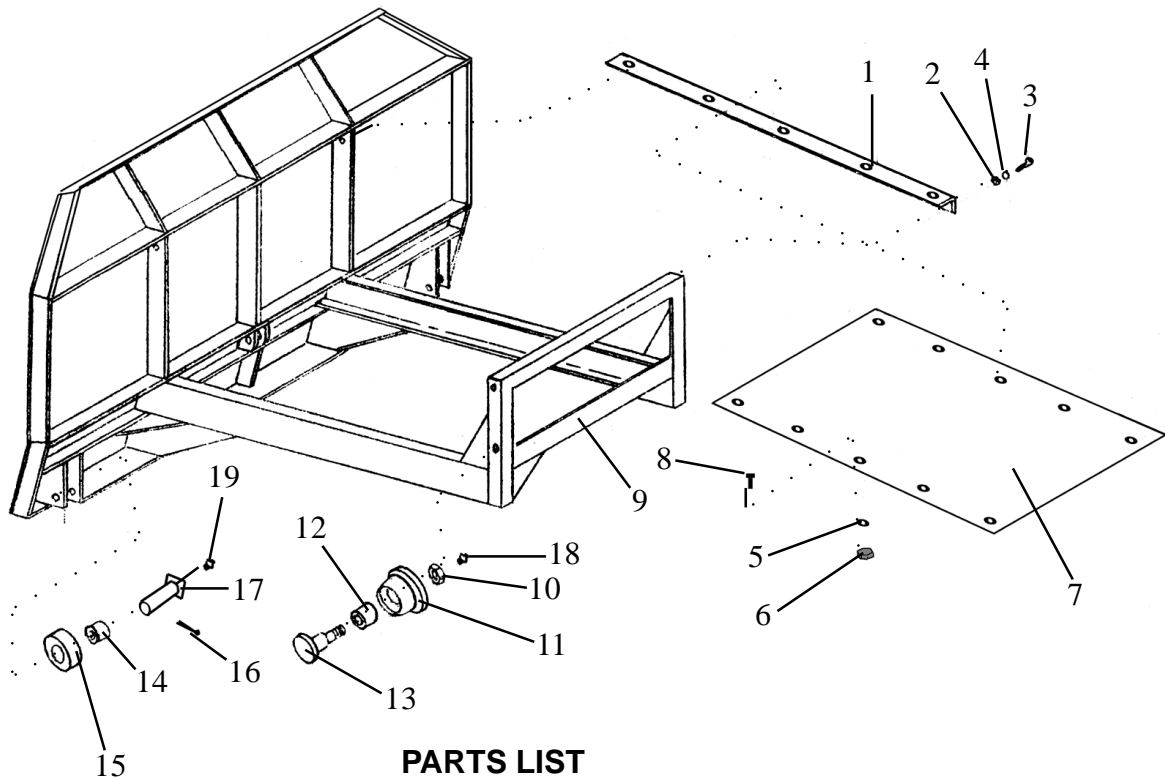

PARTS LIST PUSH OFF ASSEMBLY MODEL I-140

<u>KEY NO.</u>	<u>PART NO.</u>	<u>DESCRIPTION</u>
1.	A14022	Brace
2.	----	Nut 3/4" NC
3.	----	Bolt 3/4" NC x 1-1/2" Lg.
4.	----	Lockwasher 3/4"
5.	----	Lockwasher 3/8"
6.	----	Nut 3/8" NC
7.	A14023	Dirt Shield
8.	----	Bolt 3/8 NC x 1" Lg.
9.	A14024	Pushoff Gate, Model I-140
10.	----	Jam Nut 1-1/4" NF
11.	A10161	Roller - Rear Gate
12.	A10162	Bushing 2" OD x 1-5/8" ID
13.	A10008	Shoulder Pin 1-5/8" to 1-1/4" Zerk in Thread
14.	A10163	Bushing 1-3/4" OD x 1-1/4" ID
15.	A10164	Roller - Front Gate
16.	----	Cotter Pin 1/4" x 2" Lg.
17.	A6007A	Pin 1-1/4" x 4-1/8" Lg.
18.	----	Grease Fitting 1/8" NPT
19.	----	Grease Fitting 1/8" NPT -90 degree

FRONT WHEEL and HUB ASSEMBLY

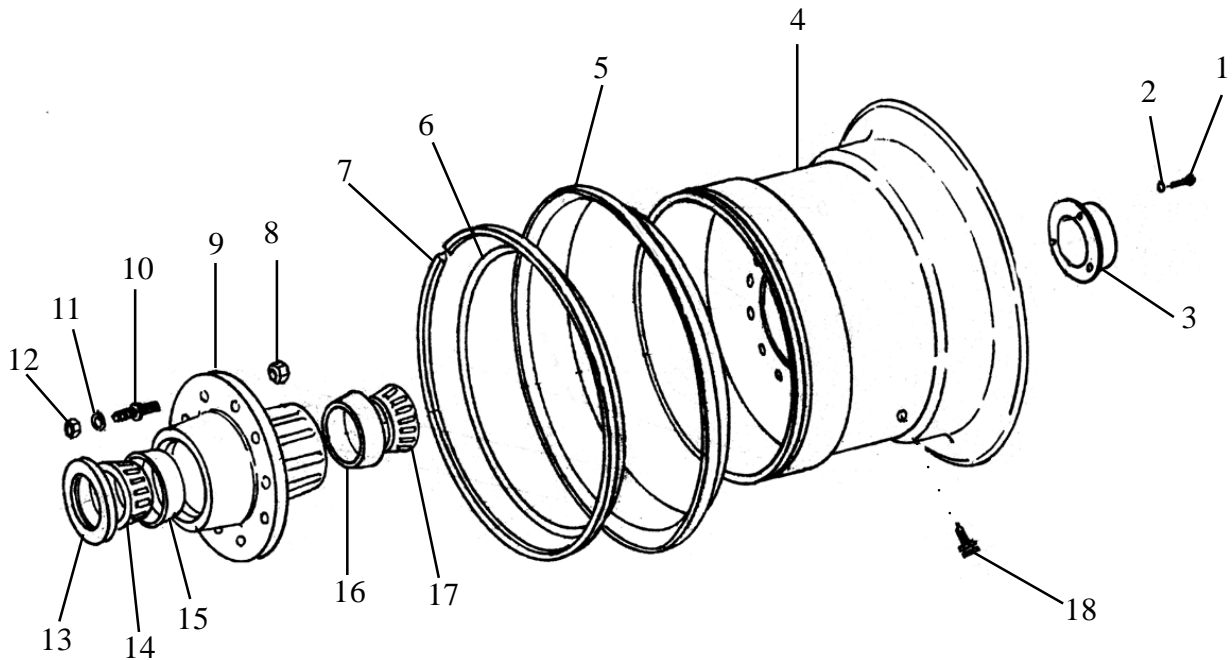

PARTS LIST FRONT WHEEL and HUB ASSEMBLY MODEL I-140

<u>KEY NO.</u>	<u>PART NO.</u>	<u>DESCRIPTION</u>
1.	-----	Bolt 5/16" NC x 5/8" Lg.
2.	-----	Lockwasher 5/16"
3.	A14004	Hub Cap
4.	A14006A	Wheel 14" x 25"
5.	A14007A	Side Ring for 14" x 25" Wheel
6.	A14008	"O" Ring
7.	A14009	Lock Ring
8.	A10046	Lug Nut
9.	A14010	Hub
10.	A10044	Lug
11.	-----	Lockwasher 3/4"
12.	-----	Nut 3/4" NF
13.	A14011	Grease Seal
14.	A14012	Bearing Cone
15.	A14013	Bearing Cup
16.	A14014	Bearing Cup
17.	A14015	Bearing Cone
18.	A14016	Valve Stem

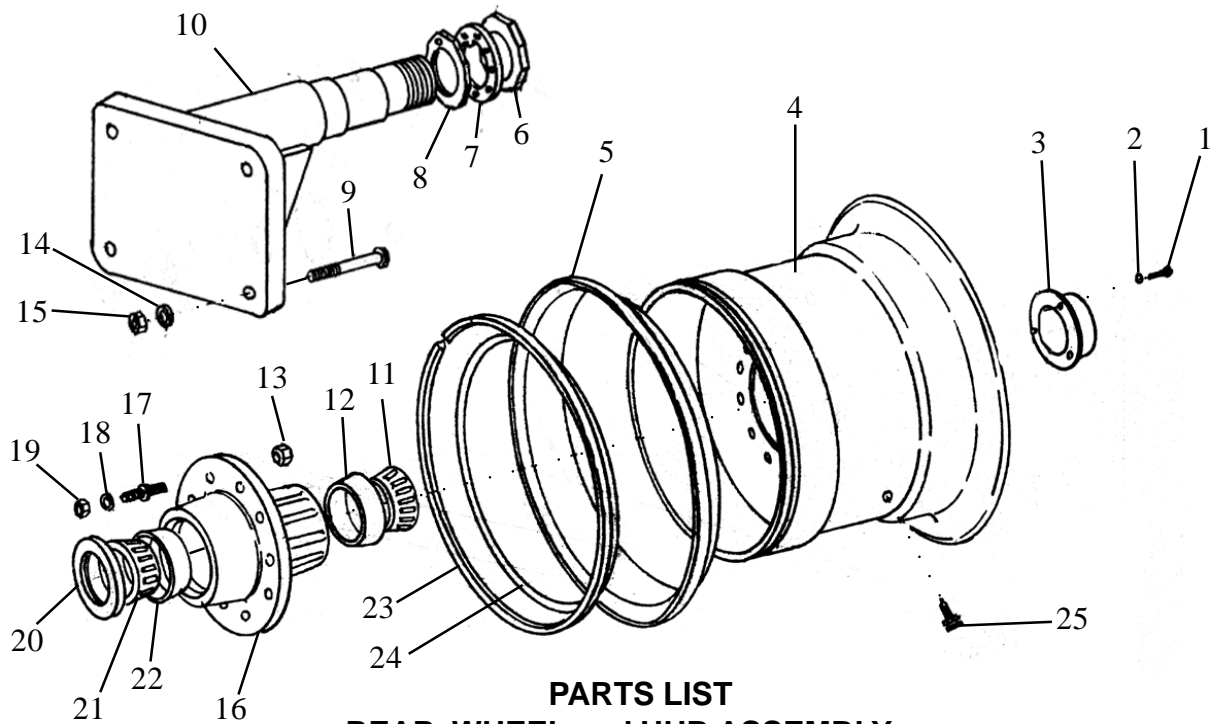

PARTS LIST
REAR WHEEL and HUB ASSEMBLY
MODEL I-140

<u>KEY NO.</u>	<u>PART NO.</u>	<u>DESCRIPTION</u>
1.	----	Bolt 5/16" NC x 5/8" Lg.
2.	----	Lockwasher 5/16"
3.	A14004	Hub Cap
4.	A14035	Wheel 17" x 25"
5.	A14036	Side Ring
6.	A10048	Spindle Nut
7.	A10049A	Lock Collar
8.	A10172	Nut with Lock Pin
9.	----	Bolt 1" NF x 7" Lg.
10.	A14037	Spindle
11.	A14015	Bearing Cone
12.	A14014	Bearing Cup
13.	A10046	Lug Nut
14.	----	Lockwasher 1"
15.	----	Nut 1" NF
16.	A14010	Hub
17.	A10044	Lug
18.	----	Lockwasher 3/4"
19.	----	Nut 3/4" NF
20.	A14011	Grease Seal
21.	A14012	Bearing Cone
22.	A14013	Bearing Cup
23.	A14038	Lock Ring
24.	A14008	"O" Ring
25.	A14016	Valve Stem

HYDRAULIC CYLINDER - A413H1, 4" X 13"
APRON CIRCUIT, RIGHT SIDE

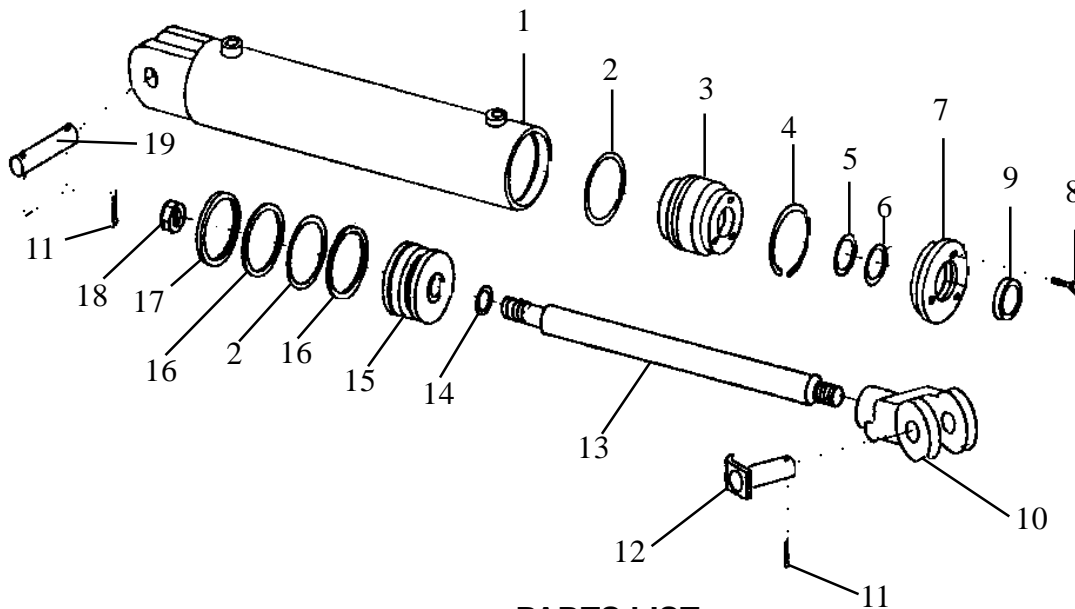

PARTS LIST
RIGHT SIDE APRON CYLINDER
 For Serial Number 17863 and up

<u>KEY NO.</u>	<u>PART NO.</u>	<u>DESCRIPTION</u>
1.	A175H013	Cylinder Barrel
2.	A300H06	"O" Ring, 4" OD x 3/16"
3.	A300H11	Head Gland
4.	A300H12	Retainer Ring
5.	A22H15	"O" Ring, 1-1/2" ID x 1/8"
6.	A22H15A	Backup Washer, 1-1/2"
7.	A300H13	Gland Cap
8.	A22H18	Capscrew, 1/4" NC x 1"
9.	A22H17	Wiper Seal, 1-1/2" ID
10.	A12H03	Clevis End
11.	-----	Cotter Pin, 3/16" x 1-1/2"
12.	A10167	Pin, 1" x 3-1/16"
13.	A175H02	Shaft, 1-1/2" Dia.
14.	A45H05	Piston Gasket, 1"
15.	A300H07	Piston, 4" Dia.
16.	A300H05	Backup Washer, 4" OD
17.	A300H04	Cast Iron Ring, 4" OD
18.	A300H03	Piston Nut, 1" NF
19.	A1217	Pin, 1" x 3-1/2"
	A300H14B	Packing Kit, Containing:
		(1) A300H04 (2) A22H15
		(2) A300H06 (1) A22H17
		(1) A45H05

3 PORT HYDRAULIC CYLINDER - AS413H1, 4" X 13"
APRON CIRCUIT, LEFT SIDE

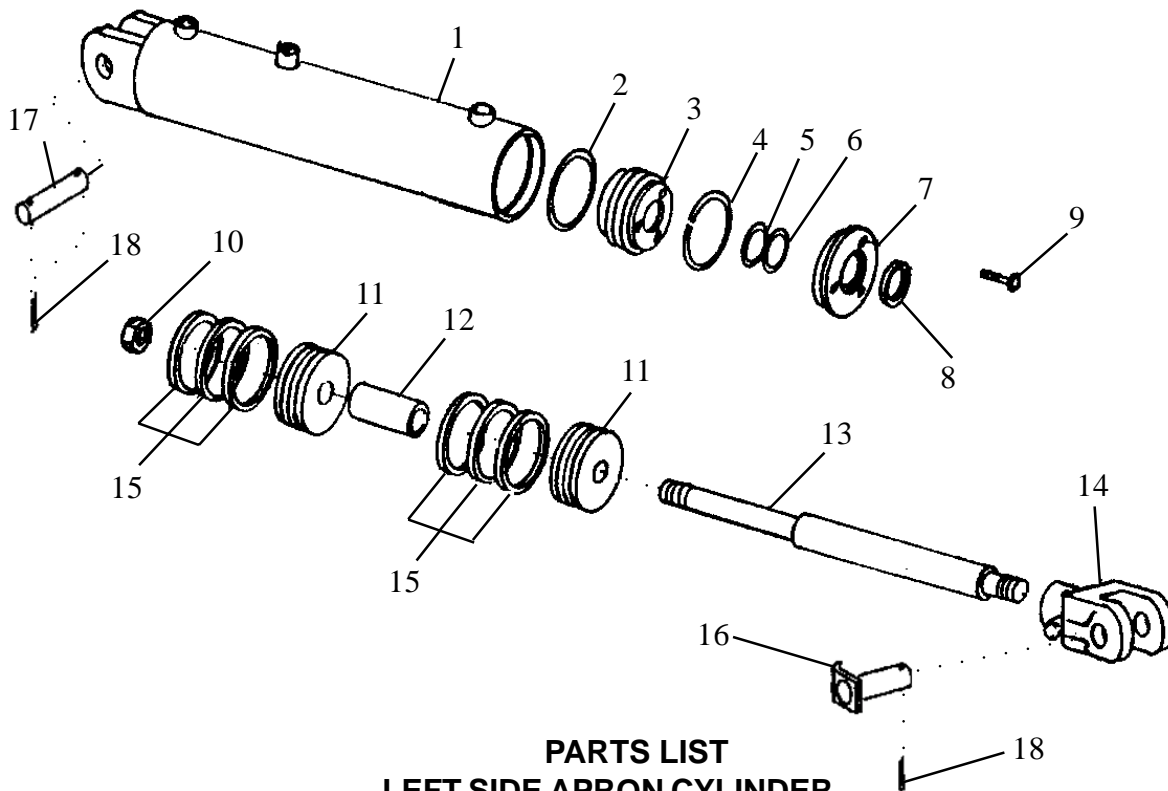

PARTS LIST
LEFT SIDE APRON CYLINDER
 For Serial Number 17863 and up

<u>KEY NO.</u>	<u>PART NO.</u>	<u>DESCRIPTION</u>
1.	A175H013	Cylinder Barrel
2.	A300H06	"O" Ring, 4" OD x 3/16"
3.	A300H11	Head Gland
4.	A300H12	Retainer Ring
5.	A22H15	"O" Ring, 1-1/2"ID x 1/8"
6.	A22H15A	Backup Washer, 1-1/2"
7.	A300H13	Gland Cap
8.	A22H17	Wiper Seal, 1-1/2" ID
9.	A22H18	Capscrew, 1/4" NC x 1"
10.	A300H03	Piston Nut
11.	A450H15	Piston, 4"
12.	A130H12	Piston Spacer
13.	A175H14	Shaft, 1-1/2"
14.	A12H03	Clevis End
15.	A300H04	Cast Iron Rings, 4" OD
16.	A10167	Pin, 1" x 3-1/16"
17.	A1217	Pin, 1" x 3-1/2"
18.	-----	Cotter Pin, 3/16" x 1-1/2"
	A130H23	Packing Kit, Containing:
		(6) A300H04 (1) A22H17
		(1) A22H15 (1) A22H15A
		(1) A300H06

**HYDRAULIC CYLINDER - A520H114 5" X 20"
LIFT CYLINDER**

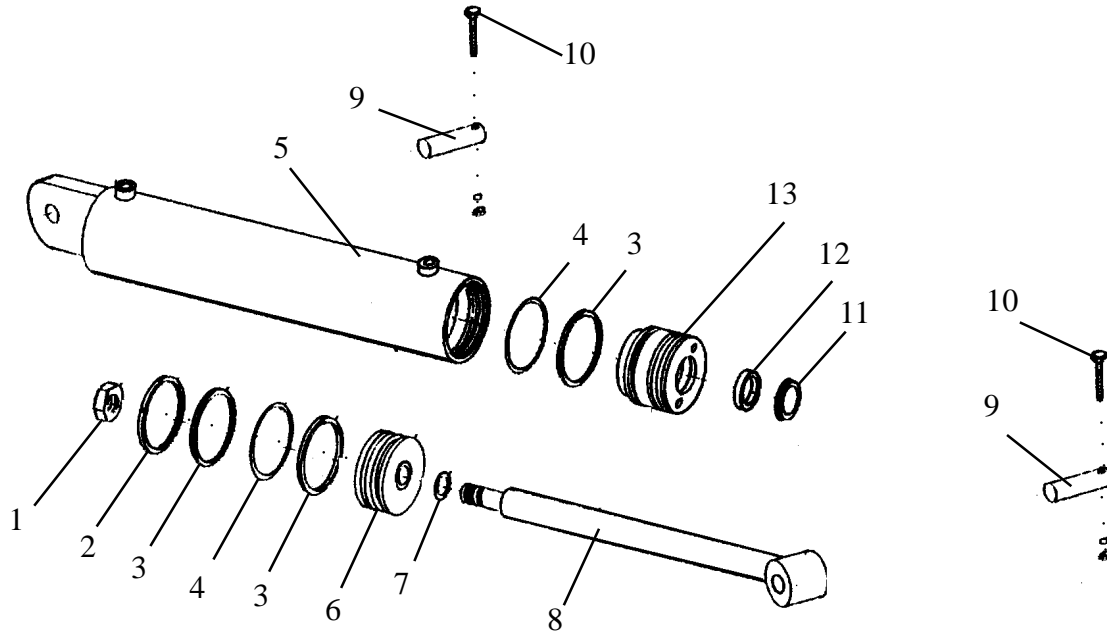

**PARTS LIST
LIFT CYLINDER**

<u>KEY NO.</u>	<u>PART NO.</u>	<u>DESCRIPTION</u>
1.	A400H17	Nut 1-1/4" NF, Lock Type
2.	A400H04	Cast Ring, 5" OD
3.	A400H05	Back-up Washer, 5" OD x 1/4"
4.	A400H06	"O" Ring, 5" OD x 1/4"
5.	A80H02A	Barrel Assembly with 1-1/4" holes
6.	A80H01	Piston, 5" OD
7.	A60H52	"O" Ring, 1-1/4" OD x 1/16"
8.	A80H08A	Shaft 2" Dia.
9.	A6007A	Pin, 1-1/4" x 4-1/8 with Square Head & Grease Hole
10.	-----	Bolt 1/4" NC x 2" Lg. with Nut & Lockwasher
11.	A80H06	Wiper Seal 2" ID
12.	A80H04	Seal 2" ID
13.	A80H05A	Head Gland
	A80H07	Packing Kit, Containing:
		(1) A400H04 (1) A60H52
		(3) A400H05 (1) A80H04
		(2) A400H06 (1) A80H06

HYDRAULIC CYLINDER - A4560H114, 4-1/2" X 60"
PUSH OFF CYLINDER

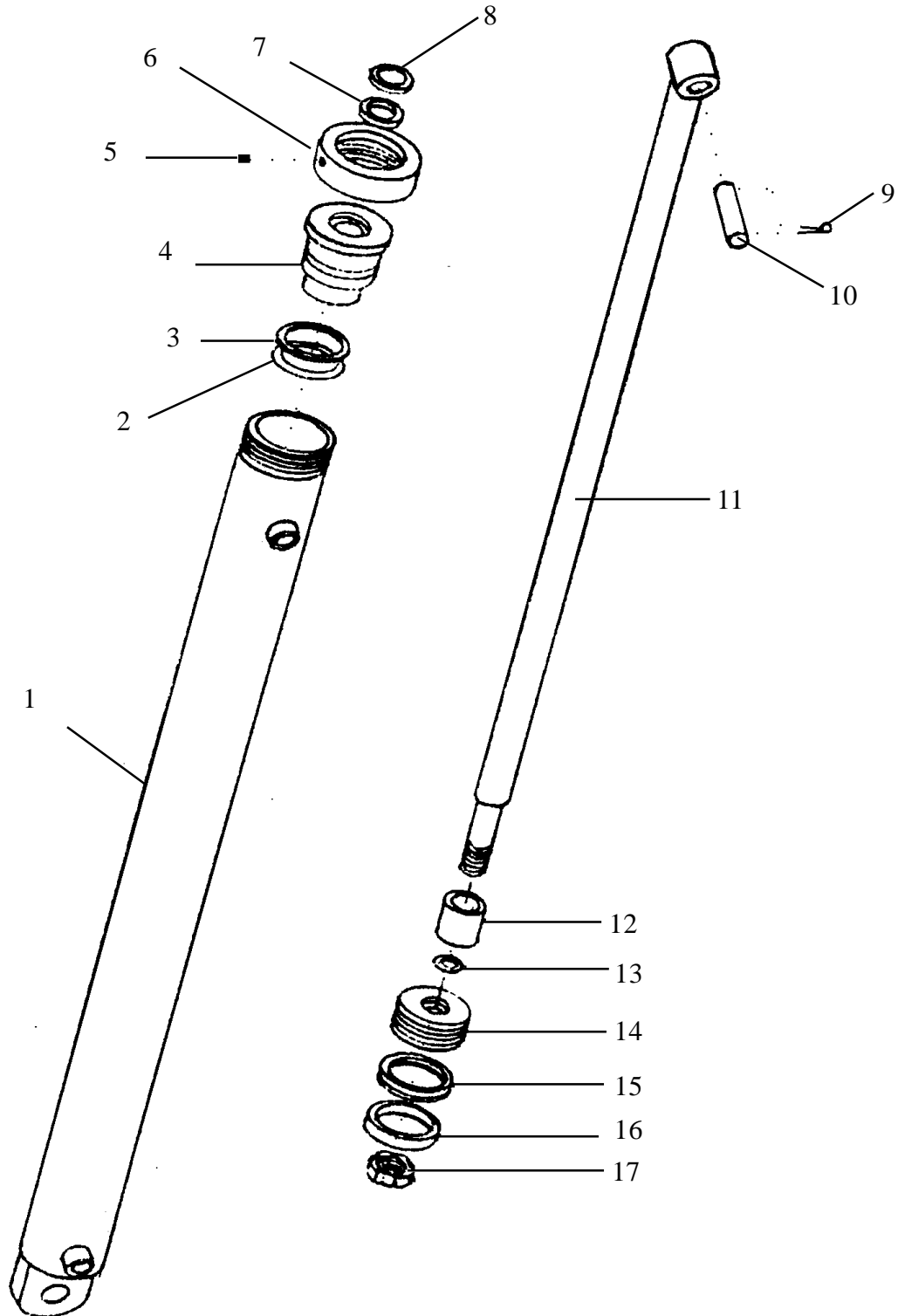

PARTS LIST
PUSH OFF CYLINDER, A4560H114, 4-1/2" x 60"
For Serial Number 17488 and up

MODEL I-140

<u>KEY NO.</u>	<u>PART NO.</u>	<u>DESCRIPTION</u>
1.	A175H08	Barrel Assembly, 4-1/2" Bore
2.	A175H03	"O" Ring, 4-1/2" OD x 4-1/8" ID
3.	A175H04	Back Up Washer, 4-1/2" OD x 4-1/8" ID
4.	A175H09	Head Gland
5.	-----	Set Screw, 3/8" NC
6.	A175H10	Collar
7.	A140H07	Shaft Seal, 2-1/2" ID, OU-Cup
8.	A140H08	Wiper Seal
9.	-----	Cotter Pin, 3/16" x 2"
10.	A10038	Pin, 1-1/4" Dia. x 4-1/4" Lg.
11.	A175H11	Shaft, 2-1/2" Dia.
12.	A175H06	Spacer
13.	A22H15	"O" Ring, 1-1/2" x 1-3/4" OD
14.	A175H12	Piston
15.	A175H05	Piston Seal, 4-1/2" OD
16.	A175H07	Wear Ring, 4-1/2" OD
17.	-----	Nut, Lock Type, 1-1/2" NF
	A175H15	Packing Kit, Containing: (1) A175H03 (1) A175H04 (1) A140H07 (1) A140H08 (1) A22H15 (1) A175H05 (1) A175H07

HYDRAULIC CIRCUIT

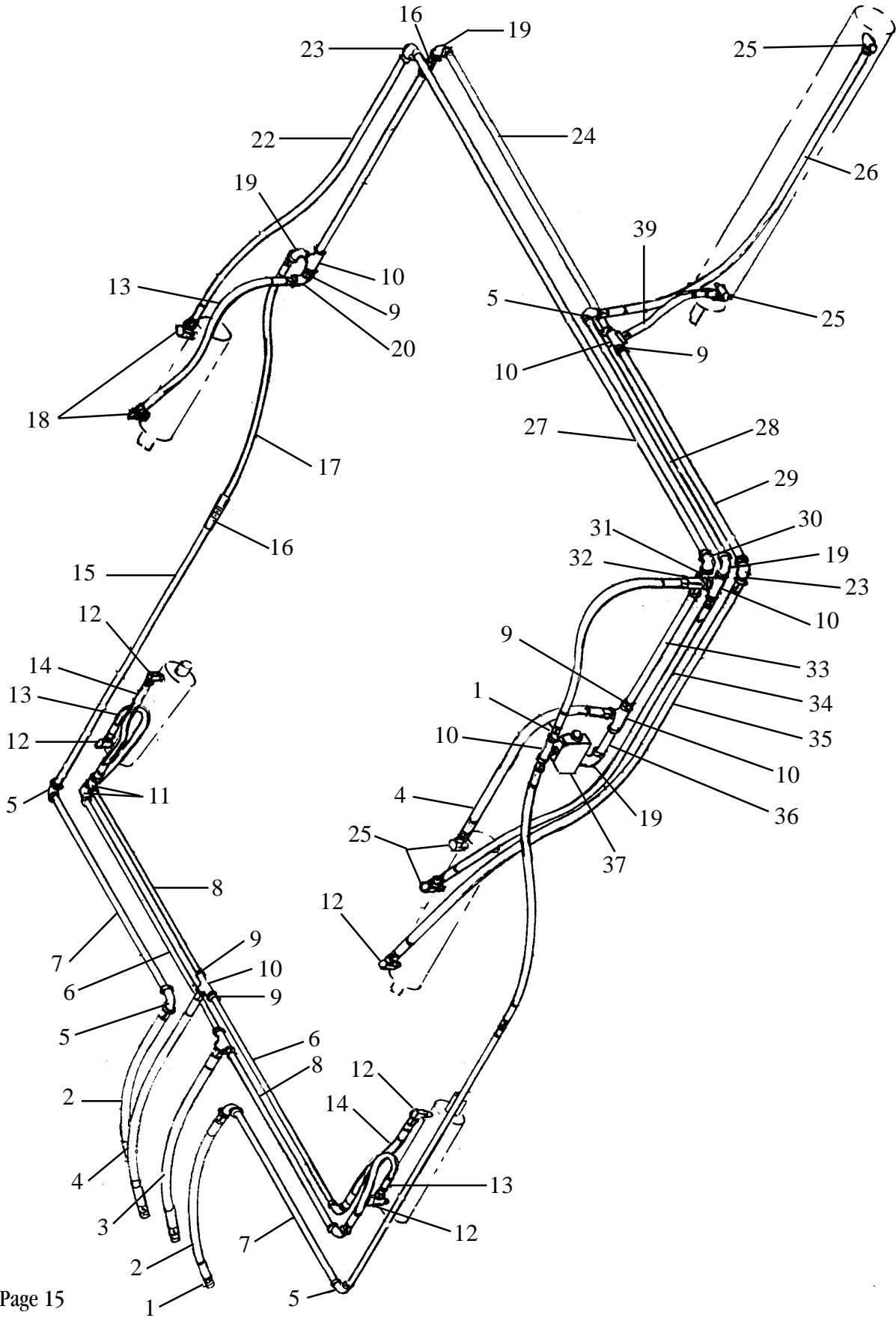

HYDRAULIC CIRCUIT PARTS LIST

MODEL I-160

<u>KEY NO.</u>	<u>NO. REQ'D</u>	<u>PART NO.</u>	<u>DESCRIPTION</u>
1.	5	A101H72	Swivel Adapter, Str. 3/4" Male x Female
2.	2	A101H32	Hose, 3/4" x 21" Long
3.	2	A101H46	Hose, 3/4" x 24-1/2" Long
4.	2	A101H31A	Hose, 3/4" x 27" Long
5.	5	----	Elbow, 90 degree x 3/4" NPT, Steel
6.	2	----	Pipe, 1/2" x 43" Long
7.	2	----	Pipe, 3/4" x 53-1/2" Long
8.	2	----	Pipe, 1/2" x 40-3/4" Long
9.	7	----	Pipe Bushing, 1/2" NPT x 3/4" NPT
10.	7	----	Pipe Tee
11.	4	----	Elbow, 90 degree, 1/2" NPT, Cast
12.	5	A400H02	Swivel adapter, 90 degree, 1/2" NPT x 1/2" NPT
13.	3	A60H01A	Hose, 1/2" x 18" Long
14.	2	A45H06	Hose, 1/2" x 24" Long
15.	2	----	Pipe, 3/4" x 80" Long
16.	3	A101H35	Swivel Adapter, Str. Female to Female, 3/4" NPT
17.	1	A101H36	Hose, 3/4" x 33" Long
18.	2	A45H07	Swivel Adapter, 90 degree, 3/8" NPT x 1/2" NPT
19.	4	----	Street Elbow, 3/4" NPT
20.	1	----	Street Elbow, 45 degree, 1/2" NPT
21.	1	----	Pipe, 3/4" x 36-1/2" Long
22.	1	A80H29	Hose, 1/2" x 46" Long
23.	2	----	Elbow, 90 degree, 1/2" NPT, Steel
24.	1	----	Pipe, 3/4" x 61" Long
25.	4	A101H77	Swivel Adapter, 90 degree, 3/4" NPT
26.	1	A140H17A	Hose, 3/4" x 77" Long
27.	1	----	Pipe, 1/2" x 107-1/2" Long
28.	1	----	Pipe, 3/4" x 50-1/2" Long
29.	1	----	Pipe, 1/2" x 46" Long
30.	1	A101H73	Street Elbow, 90 degree, 1/2" NPT, Steel
31.	1	A101H74	Swivel Adapter, Str. 1/2" NPT Female to Female
32.	1	A101H75	Check Valve
33.	1	----	Pipe, 1/2" x 12" Long
34.	1	A130H22	Hose, 3/4" x 48" Long
35.	1	A140H19	Hose, 1/2" x 60" Long
36.	1	----	Pipe, 3/4" x 5-3/4" Long
37.	1	A101H48	Counterbalance Valve
38.	1	A101H42	Hose, 3/4" x 42" Long
39.	1	A101H37	Hose, 3/4" x 18" Long

Warranty . . .

ASHLAND INDUSTRIES, INC., warrants each new unit sold to be free from defects in material and workmanship for a period of ninety (90) days of service. The obligation under this Warranty, statutory or otherwise, is limited to the replacement or repair at the Manufacturer's factory, or at a point designated by the Manufacturer of such part or parts as shall appear to the Manufacturer, upon inspection at such point, to have been defective in material or workmanship. This Warranty does not obligate the Manufacturer to bear the cost of labor or transportation charges in connection with the replacement or repair of defective parts, nor shall it apply to a unit upon which repairs or alternations have been made unless authorized by the Manufacturer.

The Manufacturer shall in no event be liable for consequential damages or contingent liabilities arising out of the failure of any unit or parts to operate properly.

No express, implied or statutory Warranty other than herein set forth is made or authorized to be made by the Manufacturer.

ASHLAND INDUSTRIES, INC.

P.O. Box 717
Ashland, Wisconsin 54806

