

Ashland **INDUSTRIES, INC.™**

*Quality
Equipment
Since
1953*

I-130-XL PARTS MANUAL

I-130XL ver 120903



Ashland Industries Inc.
1115 Rail Drive
P.O. Box 717
Ashland, WI. 54806
Ph: 877-634-4622 *Toll Free*
Ph: 715-682-4622
Fx: 715-682-9717
www.ashlandind.com

MEMBER
CIMA
CONSTRUCTION INDUSTRY
MANUFACTURERS ASSOCIATION



HOW TO ORDER PARTS:

IMPORTANT

Parts must be ordered through your local authorized ASHLAND dealer.

Be sure to state MODEL and SERIAL NUMBER of your machine, PART NUMBER, DESCRIPTION and QUANTITY needed.

Unless this is done, we cannot provide prompt service or assure shipment of the correct parts.



Ashland Industries weldable replacement parts are available to rebuild, modify or update your scraper to current factory specifications.

INDEX

| | |
|-------------|--|
| Page 3. | Safety Guidelines |
| Page 4. | Operators and Maintenance Instructions |
| Page 5. | Illustration - Assembly |
| Page 6. | Illustration and Parts List - Gooseneck Frame Assembly |
| Page 7. | Illustration and Parts List - Apron Assembly |
| Page 8. | Illustration and Parts List - Bowl and Frame Assembly |
| Page 9. | Illustration and Parts List - Push Off Gate Assembly |
| Page 10. | Illustration and Parts List - Pole and Axle Assembly |
| Page 11. | Illustration and Parts List - Front Wheel and Hub Assembly |
| Page 12. | Illustration and Parts List - Rear Wheel, Spindle and Hub Assembly |
| Page 13. | Illustration and Parts List - Hydraulic Cylinder, 4" x 13", Apron |
| Page 14. | Illustration and Parts List - Hydraulic Cylinder, 5" x 16" |
| Page 15. | Illustration and Parts List - Hydraulic Cylinder, 4-1/2" x 54" |
| Page 16. | Illustration and Parts List - Hydraulic Valve |
| Page 17. | Hydraulic Valve Adjustment Instructions |
| Page 18-22. | Service Manual Appendix |
| Page 23-24. | Troubleshooting |
| Page 25. | Warranty Statement |



SAFETY SIGNAL WORDS

Note the use of the signal words *DANGER*, *WARNING* and *CAUTION* with the safety messages. The appropriate signal word for each has been selected using the following guidelines:

DANGER: Indicates an imminently hazardous situation that, if not avoided, will result in death or serious injury. This signal word is to be limited to the most extreme situations typically for machine components which, for functional purposes, cannot be guarded.



WARNING: Indicates a potentially hazardous situation that, if not avoided, could result in death or serious injury, and includes hazards that are exposed when guards are removed. It may also be used to alert against unsafe practices.



CAUTION: Indicates a potentially hazardous situation that, if not avoided, may result in minor or moderate injury. It may also be used to alert against unsafe practices.



GENERAL SAFETY GUIDELINES

Safety of the operator is one of the main concerns in designing and developing a new piece of equipment. Designers and manufacturers build in as many safety features as possible. However, every year many accidents occur which could have been avoided by a few seconds of thought and a more careful approach to handling equipment. You, the operator, can avoid many accidents by observing the following precautions in this section. To avoid personal injury, study the following precautions and insist those working with you, or for you, follow them.

Replace any CAUTION, WARNING, DANGER or instruction safety decal that is not readable or is missing. Location of such decals is indicated in this booklet.

Do not attempt to operate this equipment under the influence of drugs or alcohol.

Review the safety instructions with all users annually.

This equipment is dangerous to children and persons unfamiliar with its operation. The operator should be a responsible adult familiar with farm machinery and trained in this equipment's operations. **Do not allow persons to operate or assemble this unit until they have read this manual and have developed a thorough understanding of the safety precautions and of how it works.**

To prevent injury or death, use a tractor equipped with a Roll Over Protective System (ROPS). Do not paint over, remove or deface any safety signs or warning decals on your equipment. Observe all safety signs and practice the instructions on them.

Never exceed the limits of a piece of machinery. If its ability to do a job, or to do so safely, is in question - **DON'T TRY IT.**

OPERATORS AND MAINTENANCE INSTRUCTIONS

This scraper is a durable piece of equipment and with proper care will yield many years of trouble free operation. The scraper requires a power source with TWO 4 way (double acting) hydraulic control valves.

The scraper should be greased at all points where grease fittings are provided. Connect hydraulic hoses to the tractor and retract lift cylinders to **REMOVE TRANSPORT LOCK PINS** (point A), then extend and retract all cylinders several times to force out any air from the hydraulic cylinders and lines. Check the oil levels in the tractor hydraulic system and add to maintain the proper level. Care should be used when adding oil or when disconnecting any oil line to keep all dirt out of the oil as dirt is a major factor in the failure of hydraulic components.

When the scraper is placed into operation, the operator will have to "feel out" the amount of depth of cut to obtain maximum loading efficiency. This is usually accomplished by taking a lesser and more uniform cut; however, some soil conditions such as loose sand may require a "pumping action" obtained by taking successive deep cuts and lifting out of cut as the tractor begins to lose power or traction.

1. After 10 hours work, all bolts should be checked and tightened if necessary.
2. Every 10 hours all grease fittings should be lubricated.
3. After 50 hours work, all bolts should be rechecked and tightened if necessary. Check wheel bearings and adjust if necessary.
4. After 300 hours work, clean and repack wheel bearings and replace, if necessary, cutting edges, worn pins, etc.

ILLUSTRATION - ASSEMBLY

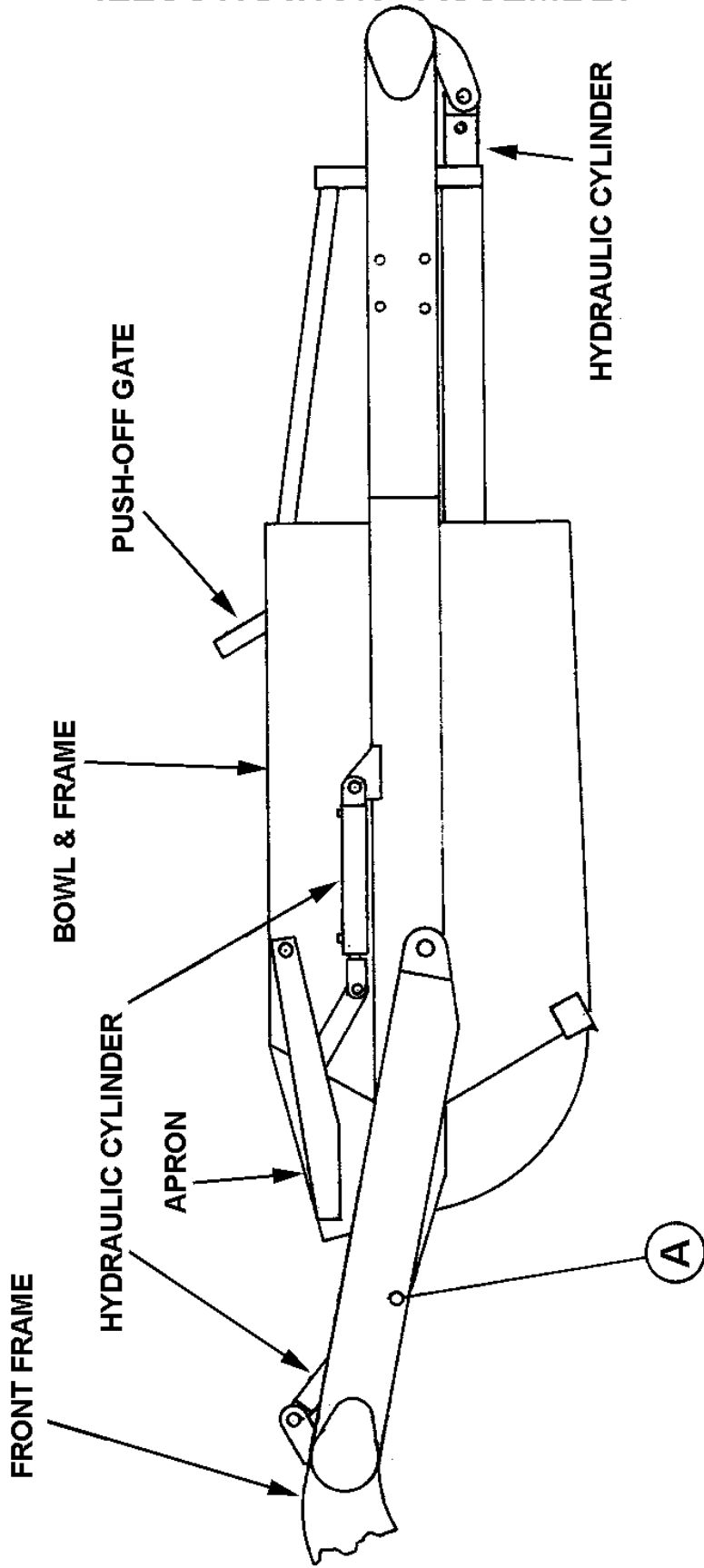

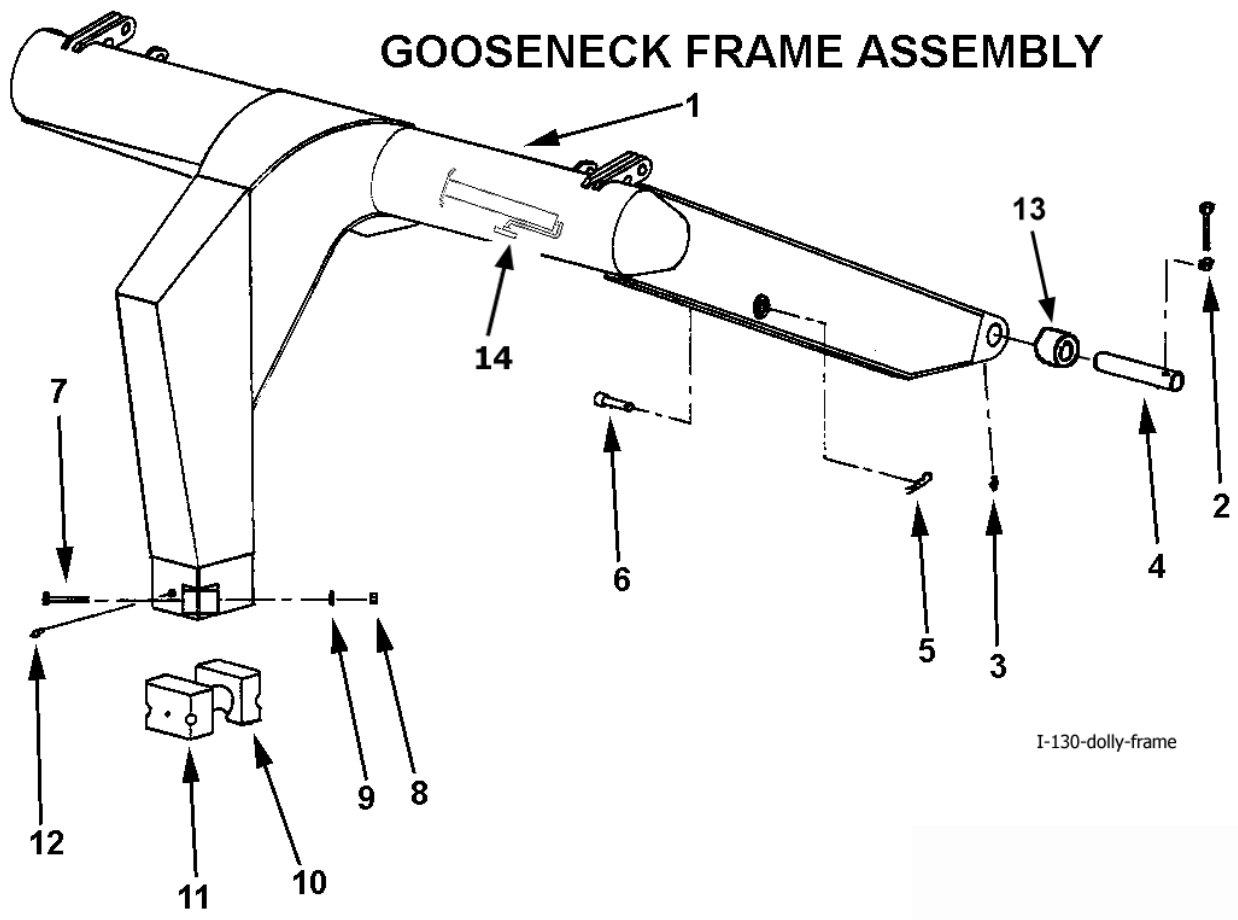

| KEY NO. | PART NO. | DESCRIPTION |
|----------------|-----------------|---|
| 1 | A13011 | Gooseneck frame |
| 2 | AFB-00054 | Bolt, 1/2" NC x 3-1/2" w/ 7500 nut |
| 3 | 14505 | Grease zerker, straight |
| 4 | A10152A | Pin, Frame attachment, 2" OD x 8-1/16" Long |
| 5 | AFP-00004 | Hair pin |
| 6 | A10153 | Pin, Transport lock |
| 7 | AFB-00025 | Bolt, 7/8" NC x 5" |
| 8 | AFN-00019 | Nut, 7/8" NC |
| 9 | 8125 | Lockwasher, 7/8" |
| 10 | A14002 | Cast socket half, rear |
| 11 | A14003 | Cast socket half, front w/ zerker hole |
| 12 | A2206 | Grease zerker, long shank |
| 13 | A14039 | Bushing, 2.375 OD x 2.00 ID x 2" Long, Grease Passage |
| 14 | OPT-00001 | Hitch jack |

I-130XL APRON ASSEMBLY

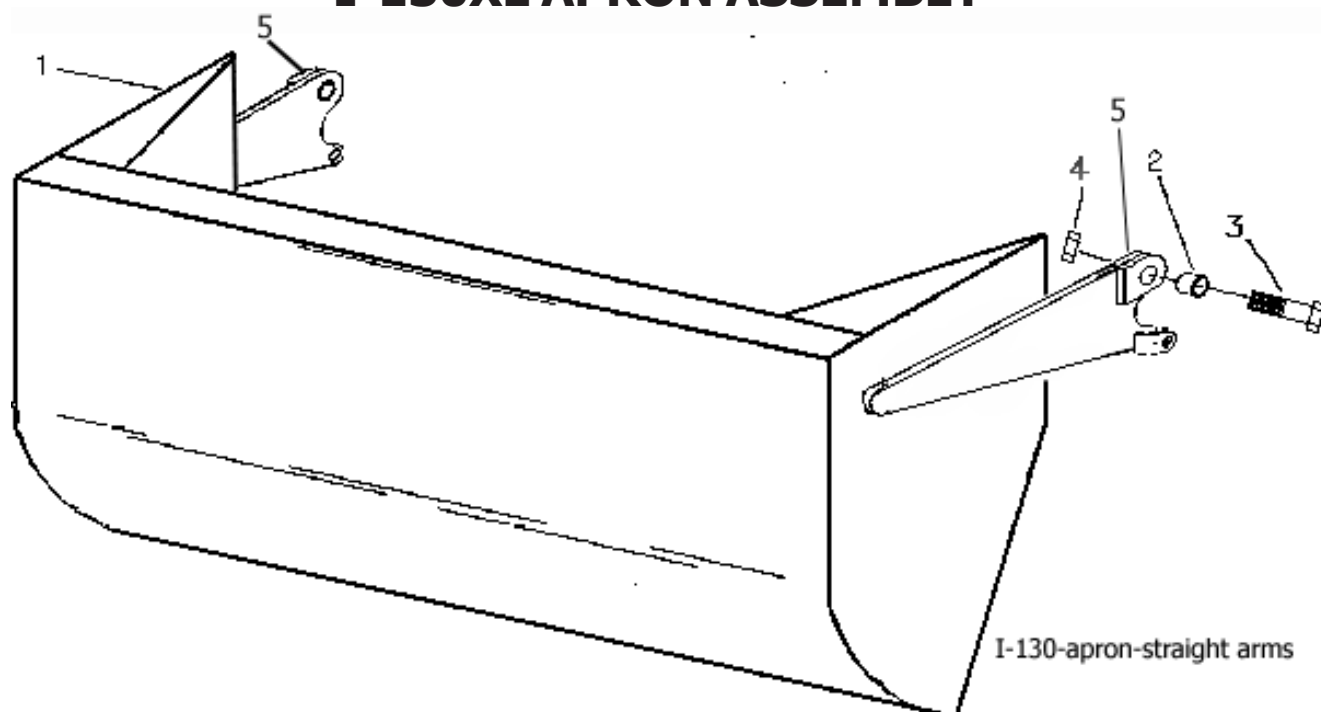

| <u>KEY NO.</u> | <u>PART NO.</u> | <u>DESCRIPTION</u> |
|-----------------------|------------------------|--|
| 1 | A123341 | Apron |
| 2 | A123343 | Bushing: 2" OD X 1-1/2" ID x 1-3/4" Long |
| 3 | AFB-00038 | Bolt, 1-1/2" NF x 5-1/2" long |
| 4 | AFN-00018 | Nut, Self lock 1-1/2" NF |
| 5 | 14505 | Grease fitting |

BOWL AND FRAME ASSEMBLY

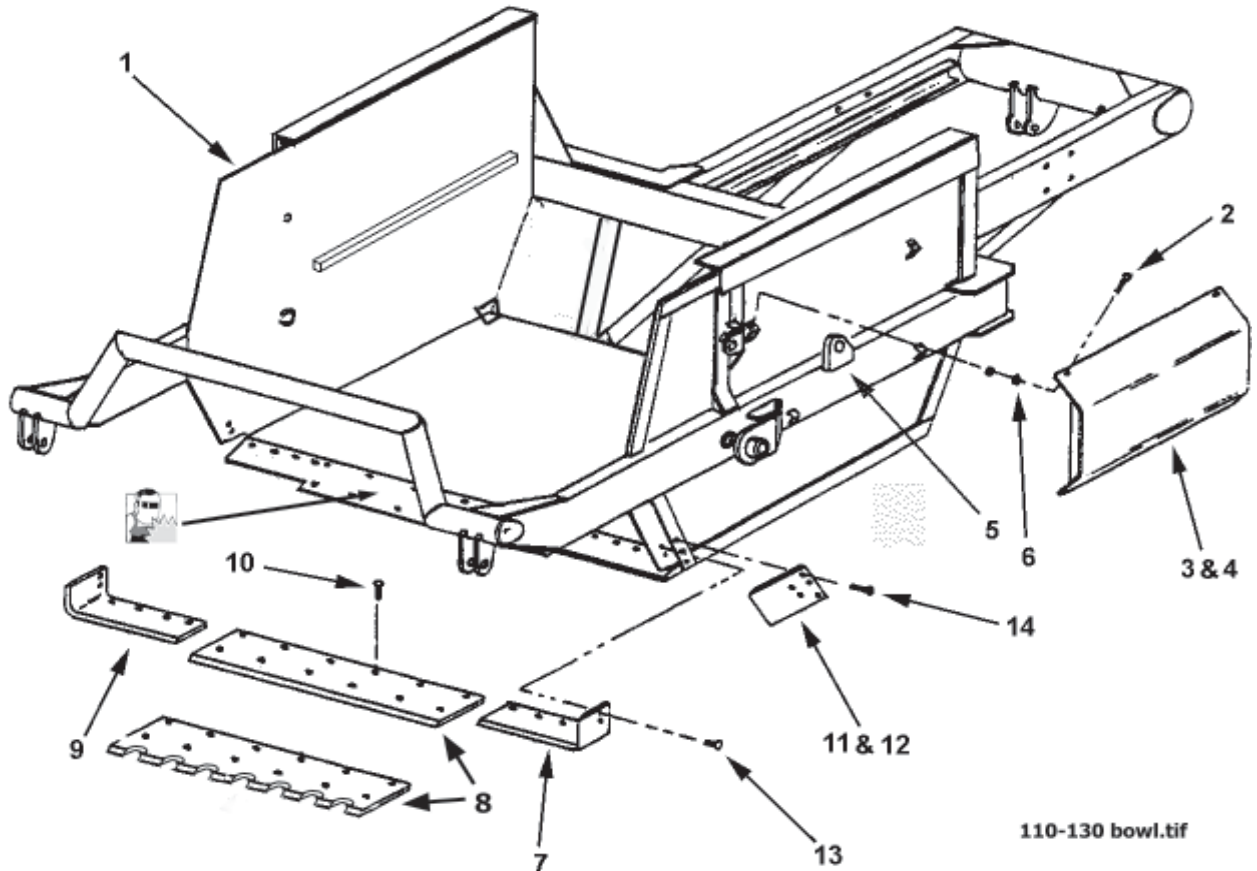

| KEY NO. | PART NO. | DESCRIPTION |
|----------------|------------------|--|
| 1 | | Bowl and Frame I-130 XL |
| 2 | 6835 | Bolt, 3/8" NC x 1" gr. 5 |
| 3 | A10157 | Left hand cylinder guard |
| 4 | A10158 | Right hand cylinder guard |
| 5 | 14505 | Grease fitting |
| 6 | 7450 | Nut, 3/8" NC gr. 5 |
| 7 | A123332L | Left cutting edge, 8" x 22-1/2" x 7/8" Hardened |
| 8 | A123331 | Center cutting edge, Straight 12" x 54" x 1", Hardened |
| | A123331SER | Center cutting edge, Serrated 12" x 54" x 1", Hardened |
| 9 | A123332R | Right cutting edge, 8" x 22-1/8" x 7/8", Hardened |
| 10 | PB9P-NC-088-0275 | Plow bolt, 7/8" NC x 2-3/4" (12 req'd) |
| | AFN-00019 | Nut: 7/8" NC (12 req'd.) |
| 11 | A123338L | (Optional) Left Bank Shaver Side Blade, 7/8" holes |
| 12 | A123338R | (Optional) Right Bank Shaver Side Blade, 7/8" holes |
| 13 | PB9P-NC-088-0275 | Plow bolt, 7/8" NC x 2-3/4" (6 req'd / blade) |
| | AFN-00019 | Nut: 7/8" NC (6 req'd / blade) |
| 14 | PB9P-NC-088-0275 | Plow Bolt, 7/8" NC x 2-3/4" (4 req'd/shaver blade) |
| | AFN-00019 | Nut: 7/8" NC (4 req'd/shaver blade) |
| | PB9P-NC-088-0225 | Plow Bolt, 7/8" NC x 2-1/4" (3 req'd/shaver blade) |
| | AFN-00026 | Nut, 7/8" Jam (3 req'd/shaver blade) |
| | | Blade Kit includes: 7, 8, 9, 10, 13 |

I-130XL PUSHOFF GATE

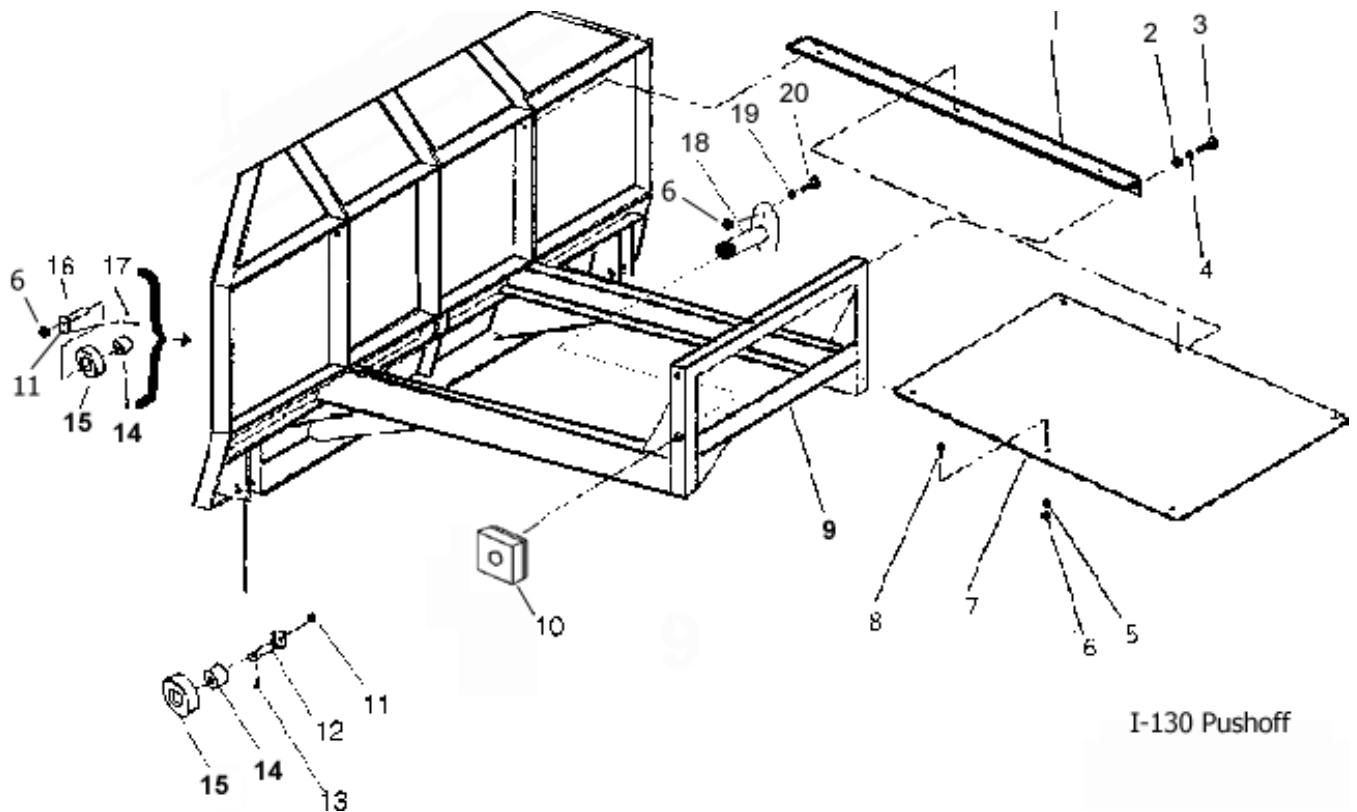

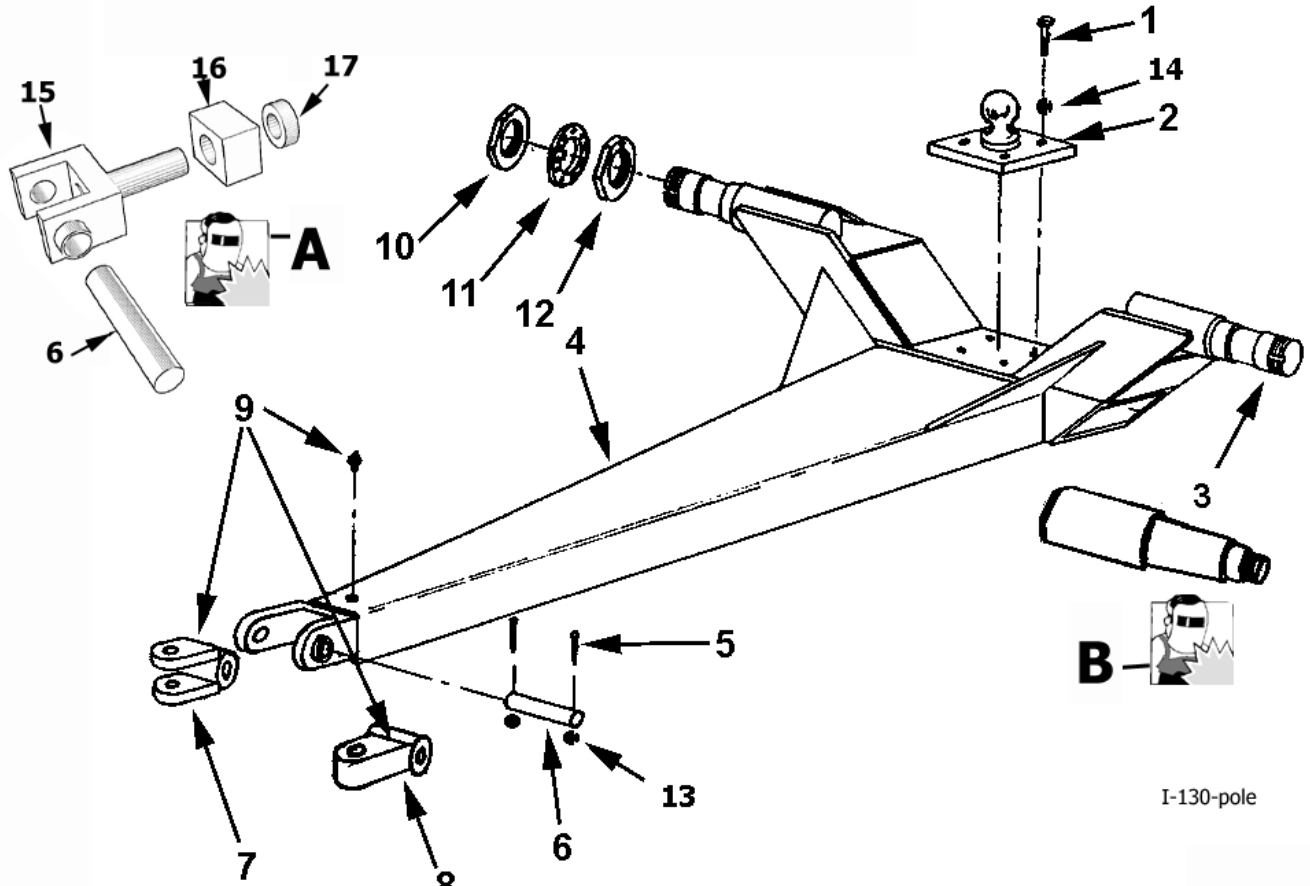

| KEY NO. | PART NO. | DESCRIPTION |
|----------------|-----------------|-------------------------------------|
| 1. | A13004 | Brace |
| 2. | AFN-00006 | Nut: 3/4" NC |
| 3. | AFB-00037 | Bolt: 3/4" NC x 2" Lg. |
| 4. | AFW-00002 | Lockwasher: 3/4" |
| 5. | 8100 | Lockwasher: 1/2" |
| 6. | 7500 | Nut: 1/2" NC |
| 7. | A10171 | Dirt Shield |
| 8. | AFB-00015 | Bolt: 1/2" x 1-1/2" NC |
| 9. | A16024 | Pushoff Gate: Model I-130 |
| 10. | A123353-K | Nylatron Slide |
| 11. | AHF-00028 | Grease Fitting: 1/8" NPT -90 degree |
| 12. | A6007A | Pin: 1-1/4" x 4-1/8" Lg. |
| 13. | AFP-00001 | Cotter Pin: 1/4 X 3-1/2" |
| 14. | A10163 | Bushing: 1-3/4" OD x 1-1/4" ID |
| 15. | A10164 | Roller: 4-1/4 OD X 1-3/4 ID |
| 16. | A123288 | Pin: 1-1/4 X 3-1/4" Tab Head |
| 17. | 7036 | Bolt: 1/2 NC X 2" |
| 18. | A123305A | Pin: 1-1/4 X 2-3/4" |
| 19. | 8100 | Lockwasher: 1/2" |
| 20. | AFB-00033 | Bolt: 1/2 NC X 2-1/2" |

I-130 POLE AND AXLE ASSEMBLY



I-130-pole

| KEY NO. | PART NO. | DESCRIPTION |
|--|-----------------|---|
| 1 | AFB-00018 | Bolt, 1" NC x 3" lg. |
| 2 | A14017 | Ball swivel |
| 3 | A14021 | Spindle (weld on) |
| 4 | A13006 | Pole |
| 5 | AFB-00056 | Bolt, 5/16" NC x 2-1/2" |
| 6 | A14019 | Pin, 1-3/4" x 7-3/8" lg. |
| 7 | A14020 | Swivel hitch, double lip (optional) |
| 8 | A14020A | Swivel hitch, single lip |
| 9 | 14505 | Grease fitting |
| 10 | A10048 | Spindle nut |
| 11 | A10049A | Lock collar |
| 12 | A10172 | Nut w/lock pin |
| 13 | 7430 | Nut, 5/16" NC |
| 14 | AFW-00006 | Lockwasher, 1" |
|  -A | A082875W | Yoke hitch rebuild kit - includes thrust block, thrust collar, yoke, cross shaft (6,15, 16, 17) |
| 15 | A082875 | Swivel yoke |
| 16 | A123166 | Swivel block |
| 17 | A083075 | Retaining Collar |
|  -B | A14021 | Spindle (weld on) blank |

FRONT WHEEL AND HUB ASSEMBLY

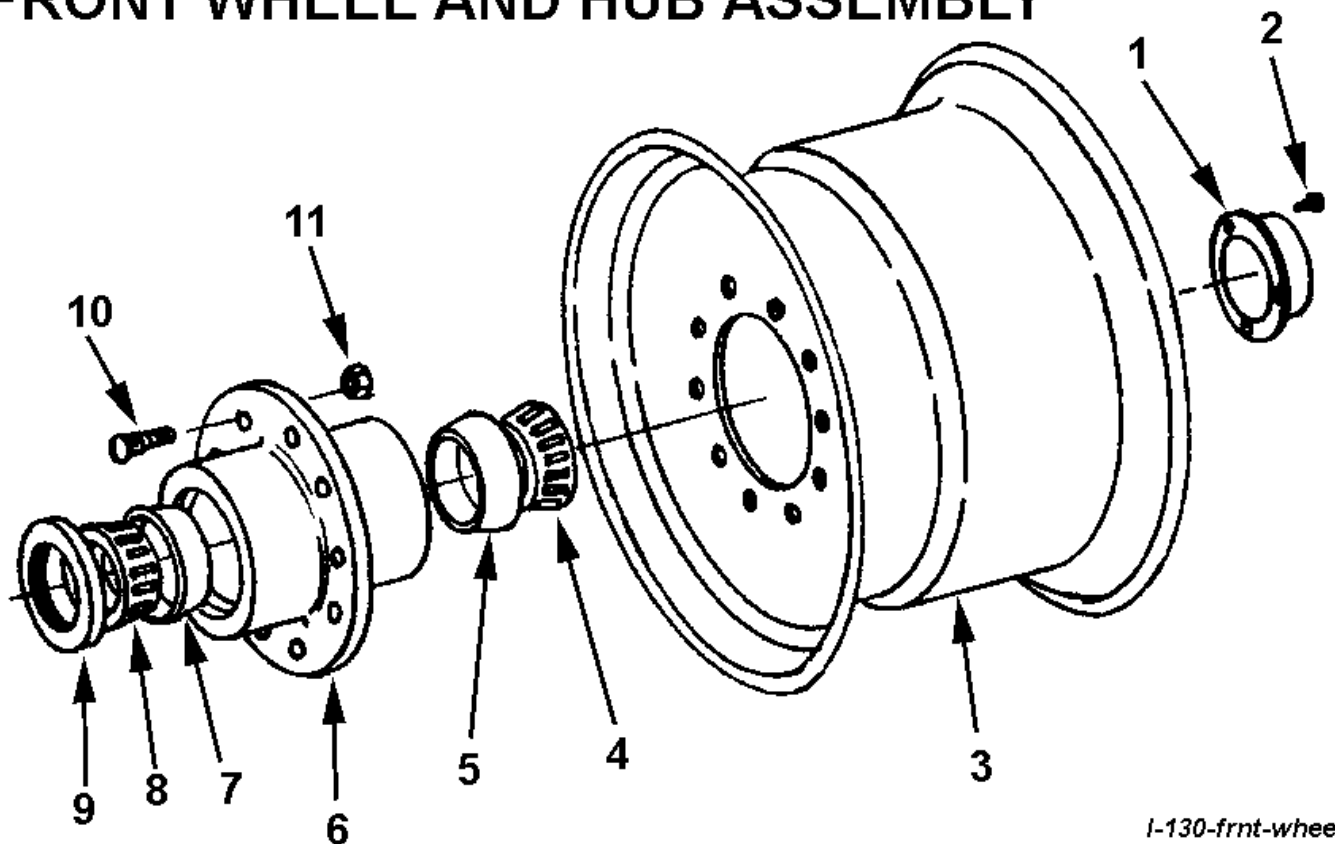

I-130-frnt-wheel

| KEY NO. | PART NO. | DESCRIPTION |
|----------------|-----------------|-----------------------------|
| 1 | A14004 | Hub cap |
| 2 | AFB-00080 | Bolt, 5/16 NC x 1/2s lg. |
| 3 | A13007 | Wheel, 18 x 16.1 |
| 4 | A14015 | Bearing cone (Timken 644) |
| 5 | A14014 | Bearing cup (Timken 632) |
| 6 | A14010 | Hub |
| 7 | A14013 | Bearing cup (Timken 742) |
| 8 | A14012 | Bearing cone (Timken 749) |
| 9 | A14011 | Grease seal (CR 42624) |
| 10 | A10176 | Stud |
| 11 | A10046 | Lug nut |

REAR WHEEL, SPINDLE & HUB ASSEMBLY

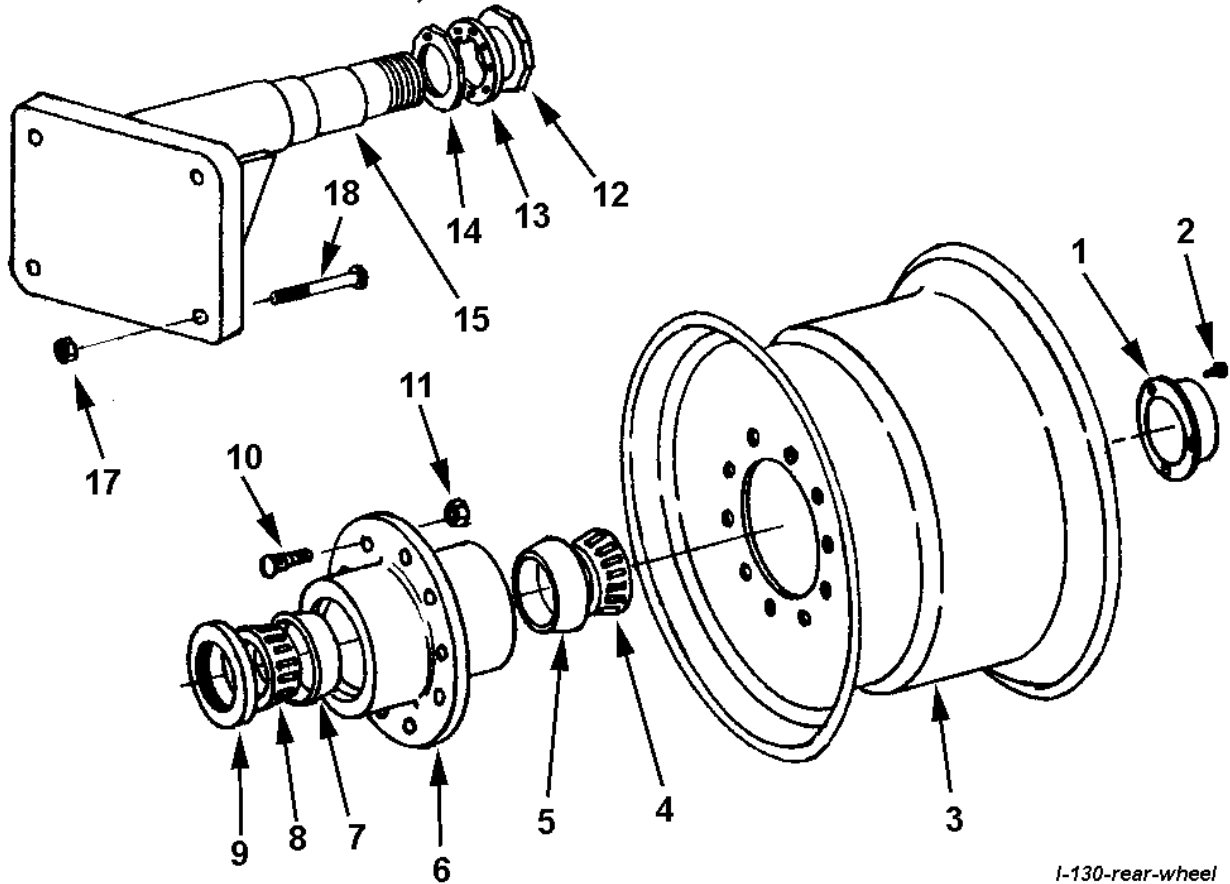

I-130-rear-wheel

| KEY NO. | PART NO. | DESCRIPTION |
|----------------|-----------------|-----------------------------|
| 1 | A14004 | Hub cap |
| 2 | AFB-00080 | Bolt, 5/16 NC x 1/2 lg. |
| 3 | A10039 | Wheel, 16 x 26 Drop Center |
| 4 | A14015 | Bearing cone (Timken 644) |
| 5 | A14014 | Bearing cup (Timken 632) |
| 6 | A14010 | Hub |
| 7 | A14013 | Bearing cup (Timken 742) |
| 8 | A14012 | Bearing cone (Timken 749) |
| 9 | A14011 | Grease seal (CR 42624) |
| 10 | A10176 | Stud |
| 11 | A10046 | Lug nut |
| 12 | A10048 | Spindle nut |
| 13 | A10049A | Lock collar |
| 14 | A10172 | Nut w/ lock pin |
| 15 | A14037 | Spindle |
| 17 | AFN-00001 | Nut, 1" NF Top Lock |
| 18 | AFB-00017 | Bolt, 1" NF x 6-1/2" lg. |

If you have 3 capscrew headcap refer to the next page.

Old Style

The older Apron Cylinder can be identified by 3/8" NPT ports & three bolts on the headcap of the gland.

New Style

The new style, effective 6-25-03, has 7/8" o-ring base ports & the gland is threaded into I.D. of the barrel. Identified by the two holes on the end of the cylinder.

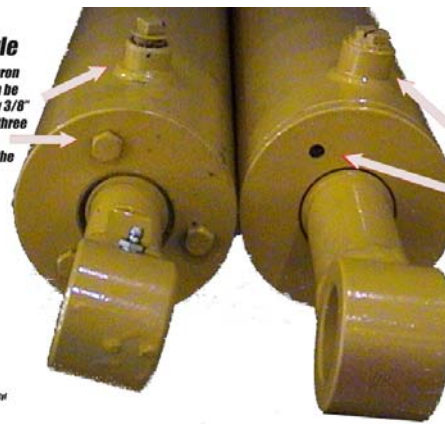

The Old vs. New Apron Cyl

Apron Cylinder
Part Number A125050
 s.n. 20750 and above
 effective 6-2003

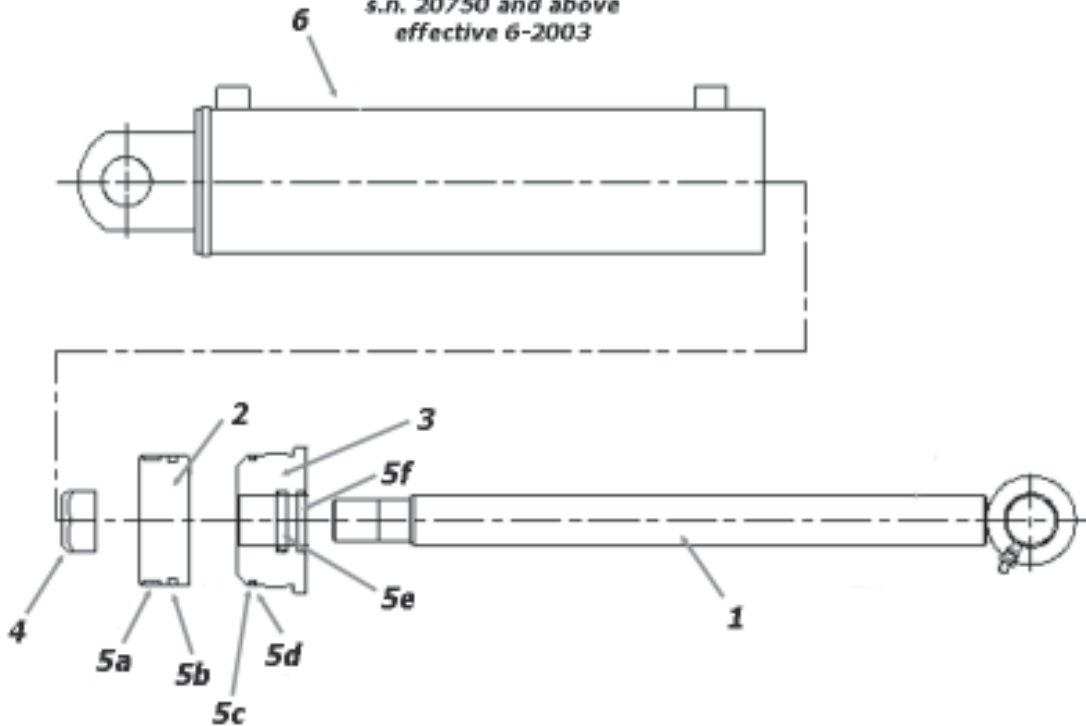

| ITEM | PART ITEM | DESCRIPTION |
|-------------|------------------|----------------------------|
| 1 | A125050-01 | Rod 1-3/4" with welded eye |
| 2 | A125050-02 | Piston |
| 3 | A125050-03 | Gland, Threaded |
| 4 | A125050-04 | Lock Nut, 1-1/8" NF |
| 5 | A125050-05 | Seal Kit, a-f |
| | A125050-05a | Nylon Wear Ring |
| | A125050-05b | FSP Seal |
| | A125050-05c | O-Ring |
| | A125050-05d | Backup Washer |
| | A125050-05e | Hallite Rod Seal |
| | A125050-05f | Snap-in Rod Wiper |

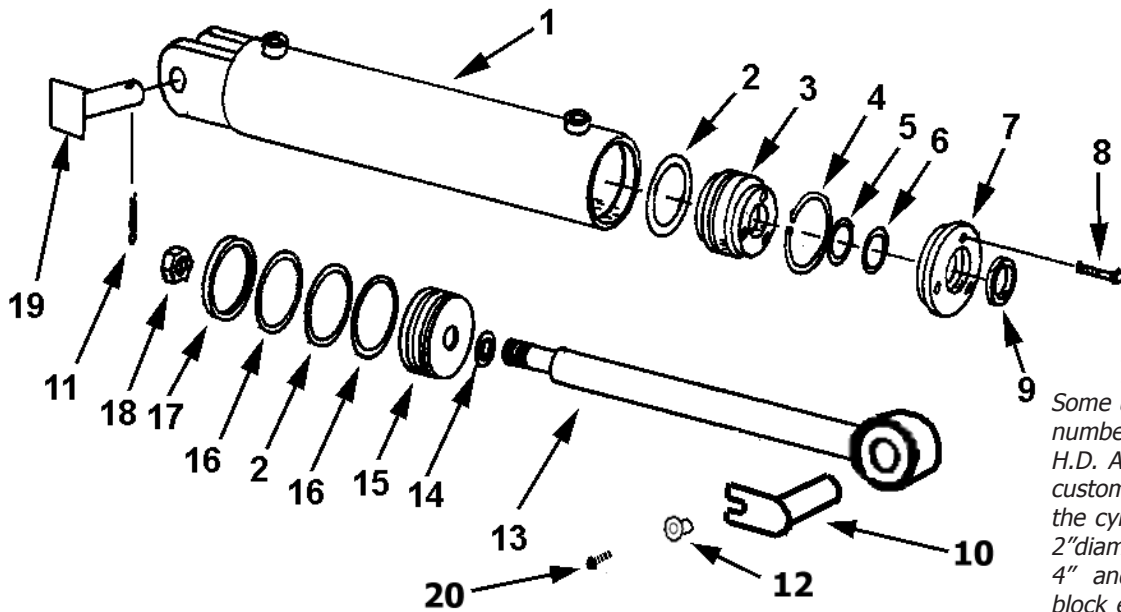

IMPORTANT
 Some units prior to this serial number were upgraded to a H.D. Apron Cylinder by the customer. Please determine if the cylinder pins are 1-1/2" diameter. If pins are 1" or 1-1/4" and is inserted into a thread block ear on the rod end please refer to page next page

**MODEL I-155 TS
 LEFT & RIGHT SIDE APRON CYLINDER 4 X 13
 PART NO. A123365**

| KEY NO. | PART NO. | DESCRIPTION |
|--|-----------------|---|
| 1. | A123365-05 | Cylinder Barrel |
| 2. | A300H06 | O-Ring: 4" OD x 3/16" |
| 3. | A300H11 | Head Gland |
| 4. | A300H12 | Retainer Ring |
| 5. | A22H15 | O-Ring: 1-1/2" ID x 1/8" |
| 6. | A22H15A | Backup Washer: 1-1/2" |
| 7. | A300H13 | Gland Cap |
| 8. | A22H18 | Capscrew: 1/4" NC x 1" |
| 9. | A22H17 | Wiper Seal: 1-1/2" ID |
| 10. | A123362 | Pin, 1-1/2" with slot for keeper bushing |
| 11. | 8602 | Pin, Cotter 1/4" x 2" Zinc |
| 12. | A123351 | Bushing, retaining flange, 9/16" ID x 3/4" OD, 3/4" L |
| 13. | A123365-03 | Rod, S/N 20497 + Welded Eye with 1-1/2" Hole |
| ** If your unit has thread block type rod end see following page ** | | |
| 14. | A45H05 | Piston Gasket: 1" |
| 15. | A300H07 | Piston: 4" Dia. |
| 16. | A300H05 | Backup Washer: 4" OD |
| 17. | A300H04 | Cast Iron Ring: 4" OD |
| 18. | A300H03 | Piston Nut, 1" NF |
| 19. | A123363 | Pin: 1-1/2" square head |
| 20 | AFB-00015 | HHCS 1/2" NC x 1-1/2" Gr. 8 |
| | A300H14B | Packing Kit, Containing: |
| | (1) A300H04 | (1) A22H15 |
| | (2) A300H05 | (1) A22H15A |
| | (2) A300H06 | (1) A22H17 |
| | (1) A45H05 | |

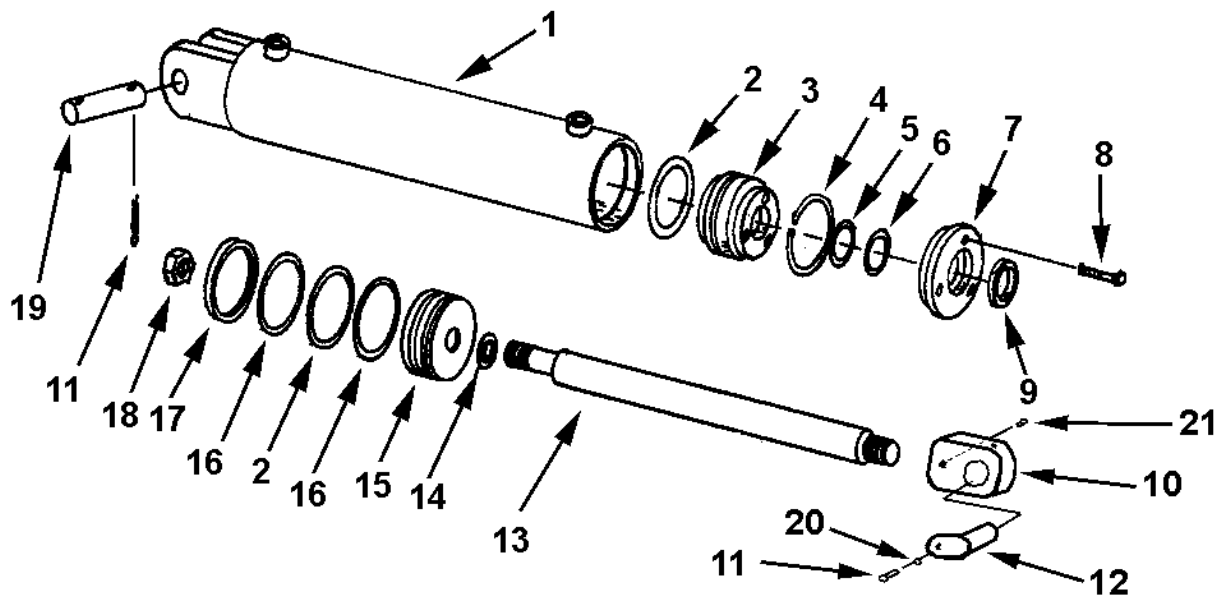

LEFT & RIGHT SIDE APRON CYLINDER 4 X 13
PART NO. A123319

IMPORTANT

Some units prior to this serial number were upgraded to a H.D. Apron Cylinder by the customer. Please determine if the cylinder pins are 1-1/2" diameter (page 20). If pins are 1" or 1-1/4" (Key # 12) and is inserted into a thread block ear (Key # 10) on the rod end please refer to this page.

| KEY NO. | PART NO. | DESCRIPTION |
|----------------|-----------------|---|
| 1. | A175H01 | Cylinder Barrel |
| 2. | A300H06 | O-Ring: 4" OD x 3/16" |
| 3. | A300H11 | Head Gland |
| 4. | A300H12 | Retainer Ring |
| 5. | A22H15 | O-Ring: 1-1/2" ID x 1/8" |
| 6. | A22H15A | Backup Washer: 1-1/2" |
| 7. | A300H13 | Gland Cap |
| 8. | A22H18 | Capscrew: 1/4" NC x 1" |
| 9. | A22H17 | Wiper Seal: 1-1/2" ID |
| 10. | A123345 | Up to S/N 20458 -Block Type, 1" Hole |
| | A123310-16 | S/N 20459 and Up - Block Type, 1-1/4" Hole |
| 11. | AFB-00015 | HHCS: 1/2 NC X 1-1/2" |
| 12. | A123336 | Up to S/N 20458 Pin: Tab Hd. w/Grs. Ftg. 1" x 3-5/8" |
| | A123347 | S/N 20459 to 20496 Pin: Tab Hd. w/Grs. Ftg. 1-1/4" x 3-5/8" |
| 13. | A175H02 | Shaft: 1-1/2" Dia. |
| 14. | A45H05 | Piston Gasket: 1" |
| 15. | A300H07 | Piston: 4" Dia. |
| 16. | A300H05 | Backup Washer: 4" OD |
| 17. | A300H04 | Cast Iron Ring: 4" OD |
| 18. | A300H03 | Piston Nut, 1" NF |
| 19. | A1217E | Pin: 1" x 3-1/2" ETD-150 |
| 20. | 8100 | Lockwasher: 1/2" |
| 21. | AFB-00062 | Socket Screw: 3/8" NC - 3/4" with Brass Tip |
| | A300H14B | Packing Kit, Containing: |
| | (1) A300H04 | (1) A22H15 |
| | (2) A300H05 | (1) A22H15A |
| | (2) A300H06 | (1) A22H17 |
| | (1) A45H05 | |

HYDRAULIC CYLINDER DIG AND LIFT CIRCUIT

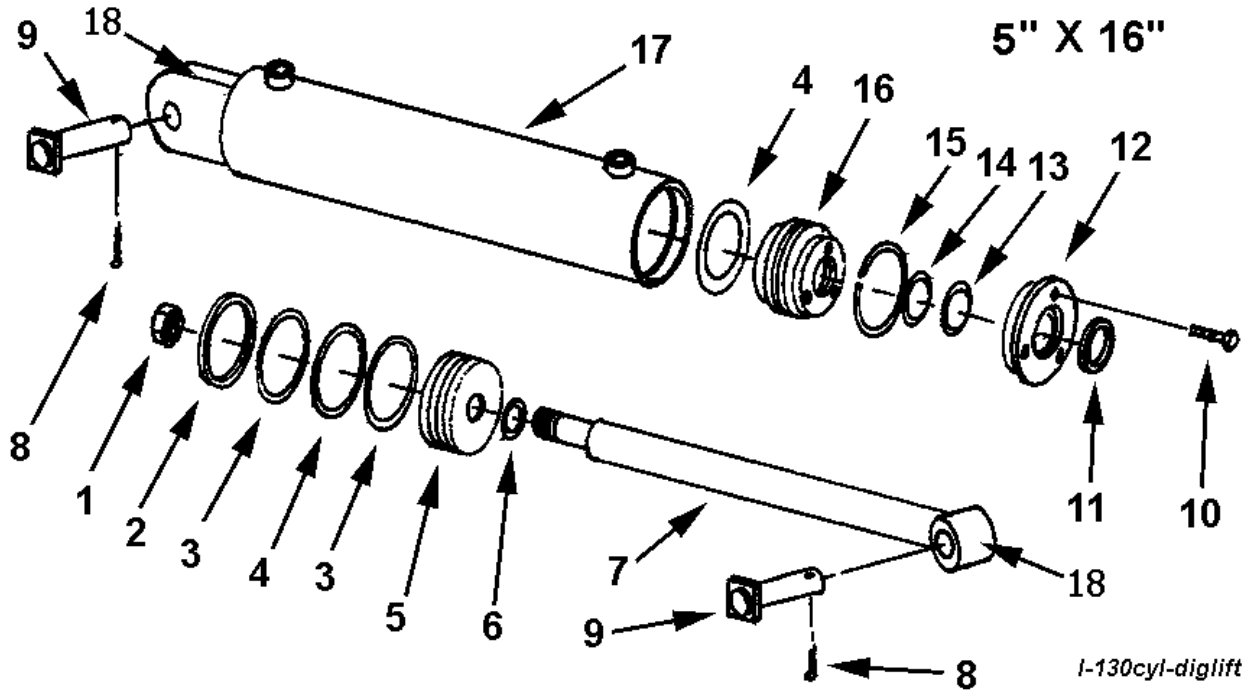

CYLINDER PART NO. A516H114A

| KEY NO. | PART NO. | DESCRIPTION |
|---------|-----------|---|
| 1 | A400H17 | Lock nut, 1-1/4" NF |
| 2 | A400H04 | Cast iron ring, 5" OD |
| 3 | A400H05 | Backup washer, 5" OD |
| 4 | A400H06 | O-ring, 5" OD x 1/4" |
| 5 | A400H07 | Piston, 5" OD |
| 6 | A60H52 | O-ring, 1-1/4" ID x 1/8" |
| 7 | A130H28 | Shaft, 2" dia. |
| 8 | 8602 | Cotter pin, 1/4" x 2" |
| 9 | A123383 | Pin, 1-1/4" x 4-1/4" |
| 10 | A22H18A | Capscrew, 5/16" NC x 1" |
| 11 | A400H14 | Wiper seal |
| 12 | A400H13 | Head cap |
| 13 | A400H12 | O-ring, 2" ID |
| 14 | A400H12A | Backup washer, 2" ID |
| 15 | A400H11 | Retainer ring |
| 16 | A400H10 | Head gland, 5" OD |
| 17 | A130H27 | Barrel Assembly, 5" ID |
| 18 | 14505 | Grease fitting |
| | A400H15C | Packing kit containing: |
| | | 1 - A400H04 1 - A400H11 2 - A400H05 |
| | | 1 - A400H14 2 - A400H06 1 - A400H12 |
| | | 1 - A60H52 1 - A400H12A |
| 19 | 030672-33 | Dog bone (Not Shown) |

I-130 PUSH GATE CYLINDER ASSEMBLY

PART NO. A455H114

4 1/2" BORE X 54" STROKE - MODEL I-130 (SERIAL NO. 17870 & UP)

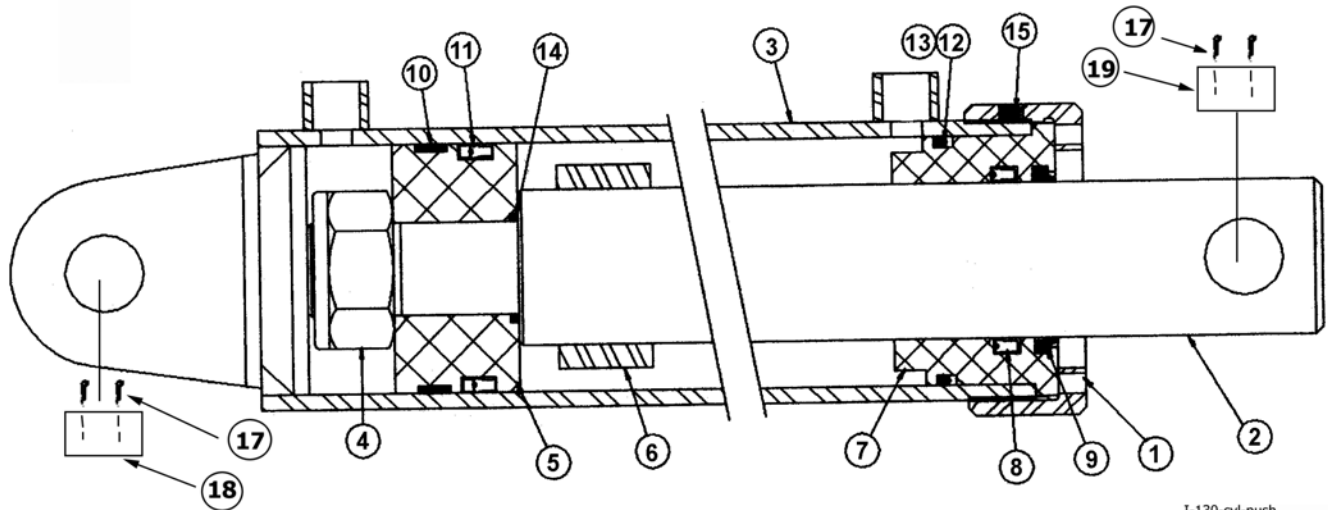

I-130-cyl-push

| KEY NO. | PART NO. | DESCRIPTION |
|----------------|-----------------|-------------------------------------|
| 1 | A175H10 | Collar |
| 2 | A130H30 | 2 1/2" Rod |
| 3 | A130H29 | Barrel weldment |
| 4 | A140H13 | Lock nut (2" - 12) |
| 5 | A175H12 | Piston |
| 6 | A17506 | Spacer |
| 7 | A175H09 | Head |
| 8 | A140H07 | Rod seal |
| 9 | A140H08 | Rod wiper |
| 10 | A175H07 | Wear ring |
| 11 | A175H05 | Piston seal |
| 12 | A175H03 | O-ring |
| 13 | A175H04 | Backup ring |
| 14 | A140H14 | O-ring |
| 15 | AFB-00061 | Nylon tip set screw (3/8" NC x 3/8) |
| 16 | A175H15 | Seal kit (Items 8-14) |
| 17 | 8602 | Cotter pin, 1/4" x 2" |
| 18 | A9024 | Pin, 1-1/4" diameter x 4-3/4" long |
| 19 | A14033 | Pin, 1-1/4" diameter x 5" long |

HYDRAULIC VALVE IDENTIFICATION



New Valve



Old Valve

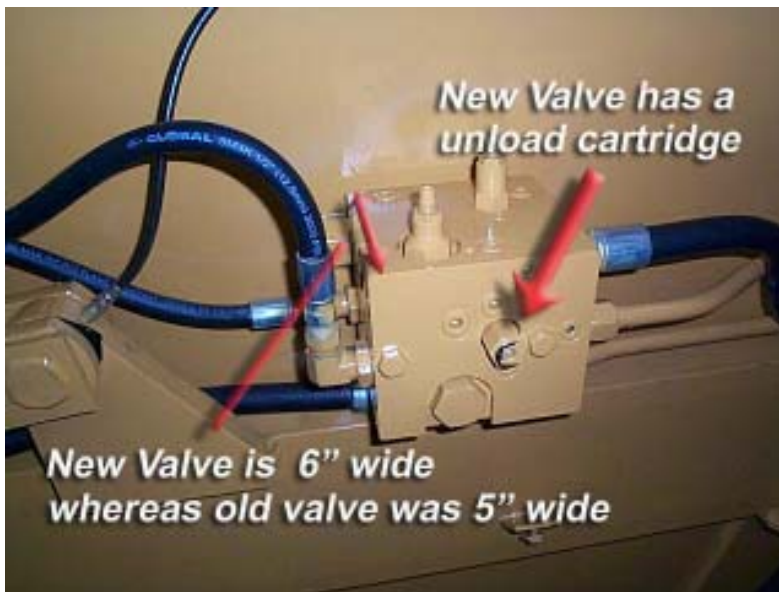

Visually there are several things you can check to ensure you have the correct valve. The new valve (shown on the left) is 6" wide whereas the older valve (shown below) was 5" wide. The new valve utilizes a unload cartridge that sticks outward on the side of the valve.



IMPORTANT

This Hyd. Manifold was intergrated into production Nov. 2003 It replaces t A125055 valve which was used S.N. 20750 to 20853 To confirm what valve you have confirm with earlier valve I.D. page

HYDRAULIC MANIFOLD ASSEMBLY

A125070

S.N. 20853 & above

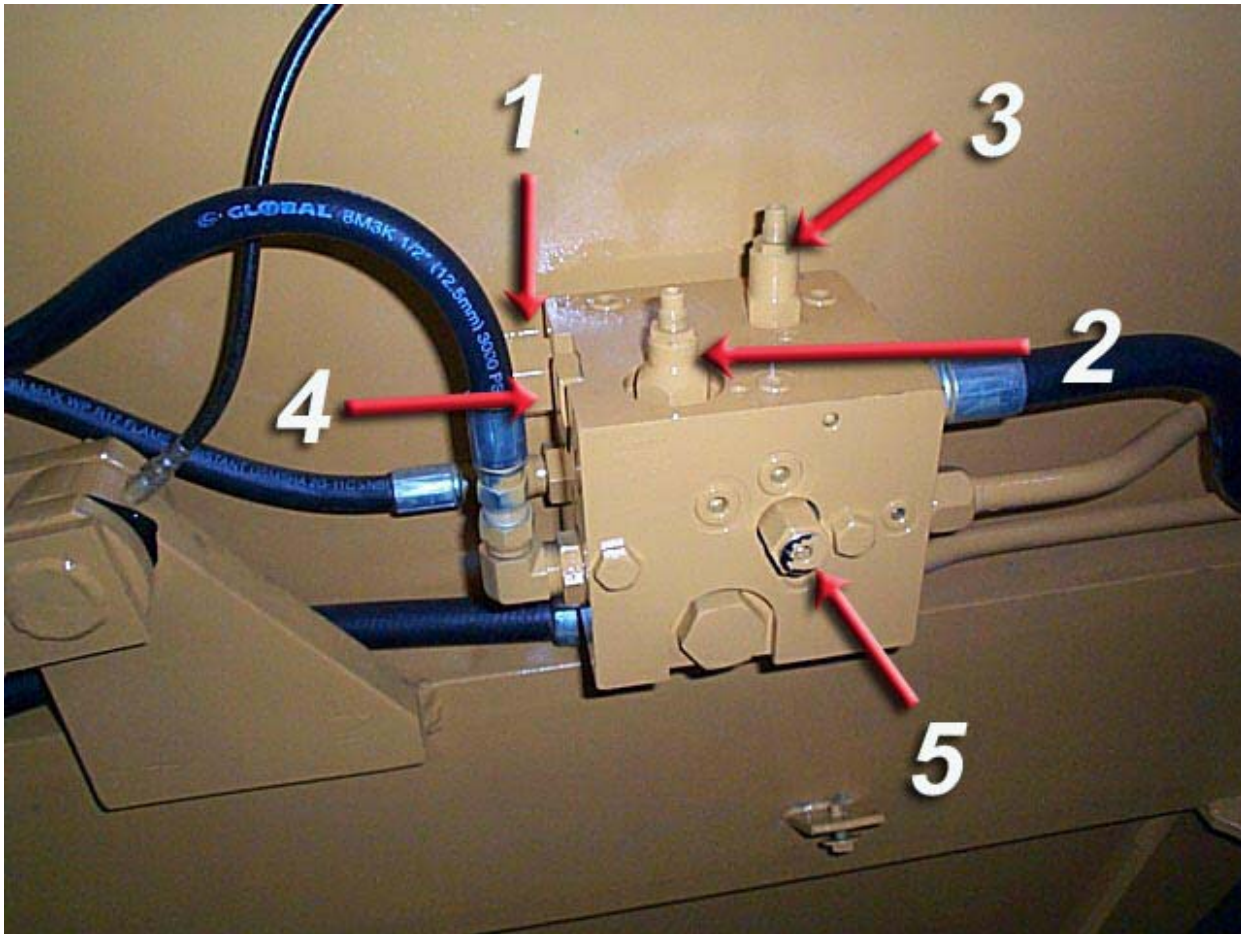

A125070 HYDRAULIC MANIFOLD

| ITEM # | PART NO. | DESCRIPTION |
|--------|------------|----------------------------|
| 1 | A125070-01 | DIRECTIONAL CONTROL VALVE |
| 2 | A125070-02 | APRON SEQUENCE CARTRIDGE |
| 3 | A125070-03 | PUSHOFF SEQUENCE CARTRIDGE |
| 4 | A125070-04 | CHECK VALVE CARTRIDGE |
| 5 | A125070-05 | UNLOAD CARTRIDGE |

IMPORTANT

This Hyd. Manifold has been replaced by A125070 on Nov 2003. To confirm what valve you have confirm with earlier valve I.D. page

HYDRAULIC MANIFOLD ASSEMBLY

A125055

S.N. 20750 to 20853

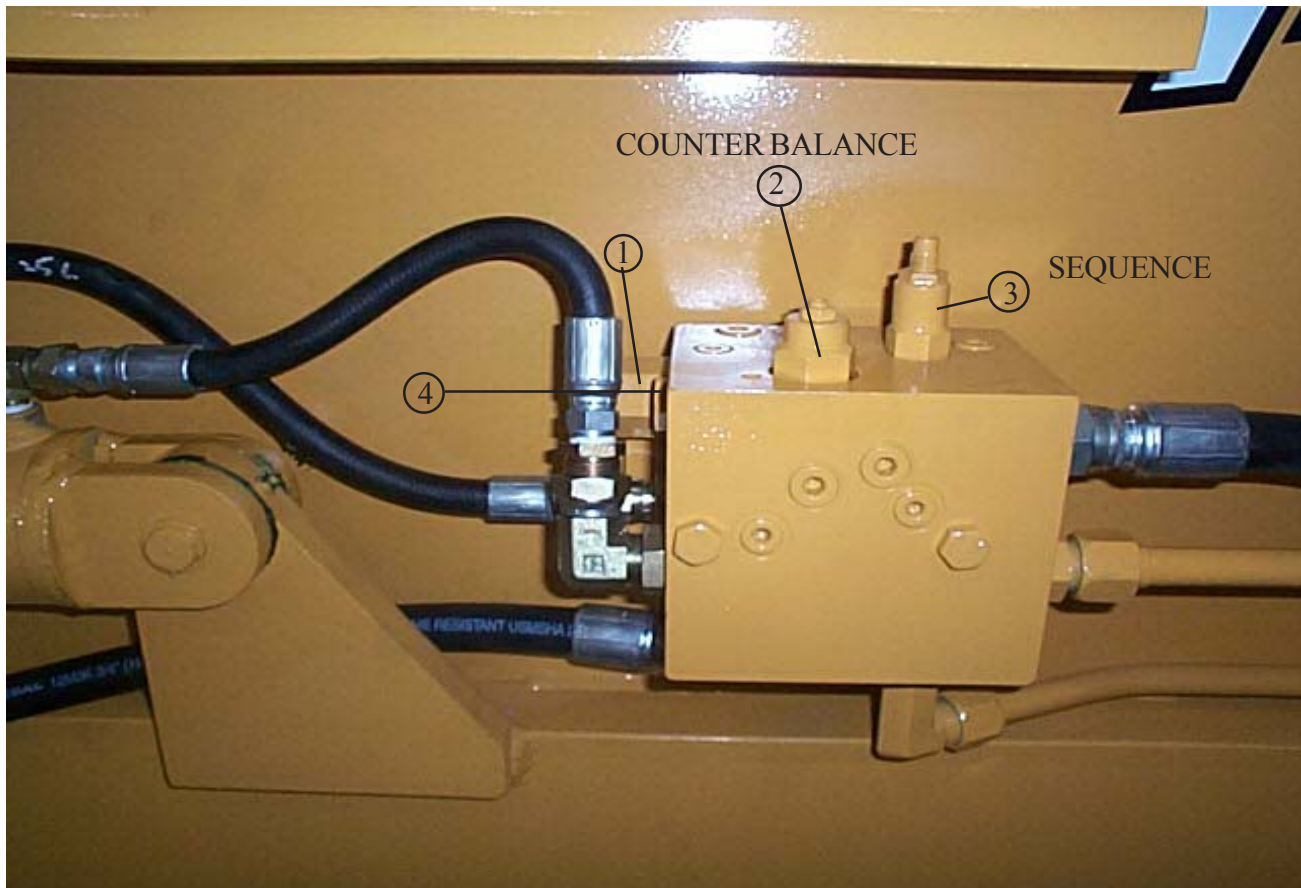

| ITEM NO. | PART NO. | DESCRIPTION |
|----------|------------|-----------------------------------|
| 1 | A125055-01 | DIRECTIONAL CONTROL VALVE |
| 2 | A125055-02 | COUNTER BALANCE CARTRIDGE |
| 3 | A125055-03 | SEQUENCE CARTRIDGE |
| 4 | A125055-04 | CHECK VALVE |
| 5 | A125055 | COMPLETE ASSEMBLY WITH ALL VALVES |

SETTING THE APRON AND PUSHOFF VALVE

The manifold block containing the pushoff sequence valve cartridge and apron sequence valve cartridge is used to control two hydraulic circuits with one hydraulic remote. When the tractor hydraulic remote is activated, oil flows first to the apron cylinders until they are fully extended. Once the cylinders are fully extended, the apron circuits' hydraulic pressure begins to increase. Once the pressure threshold is surpassed (which is adjustable. See adjustment section), the sequence valve diverts the oil flow to the pushoff's hydraulic circuit. Once the push off is completely extended the operator then reverses the tractor's hydraulic remote. The counterbalance valve will hold the apron open until the push off is fully retracted. The Apron sequence valve then opens and allows the apron to close.

Setting the valves

STEP 1 PUSHOFF SEQUENCE VALVE

Loosen the lock nut (3/4") on the sequence valve cartridge. Turn the setscrew (1/4") clockwise until the front apron rises before the push-off begins to advance. (Earthmover should be empty) Turn the adjustment screw an additional 1/4 turn clockwise and tighten jam nut.

STEP 2 APRON SEQUENCE VALVE

Loosen the lock nut (3/4") on the counterbalance valve cartridge. Turn the setscrew (4 mm) clockwise until the apron holds in a raised position while rear gate is being retracted. Turn adjustment screw an additional 1/4 turn, tighten jam nut. DO NOT tighten adjusting screw more than necessary.

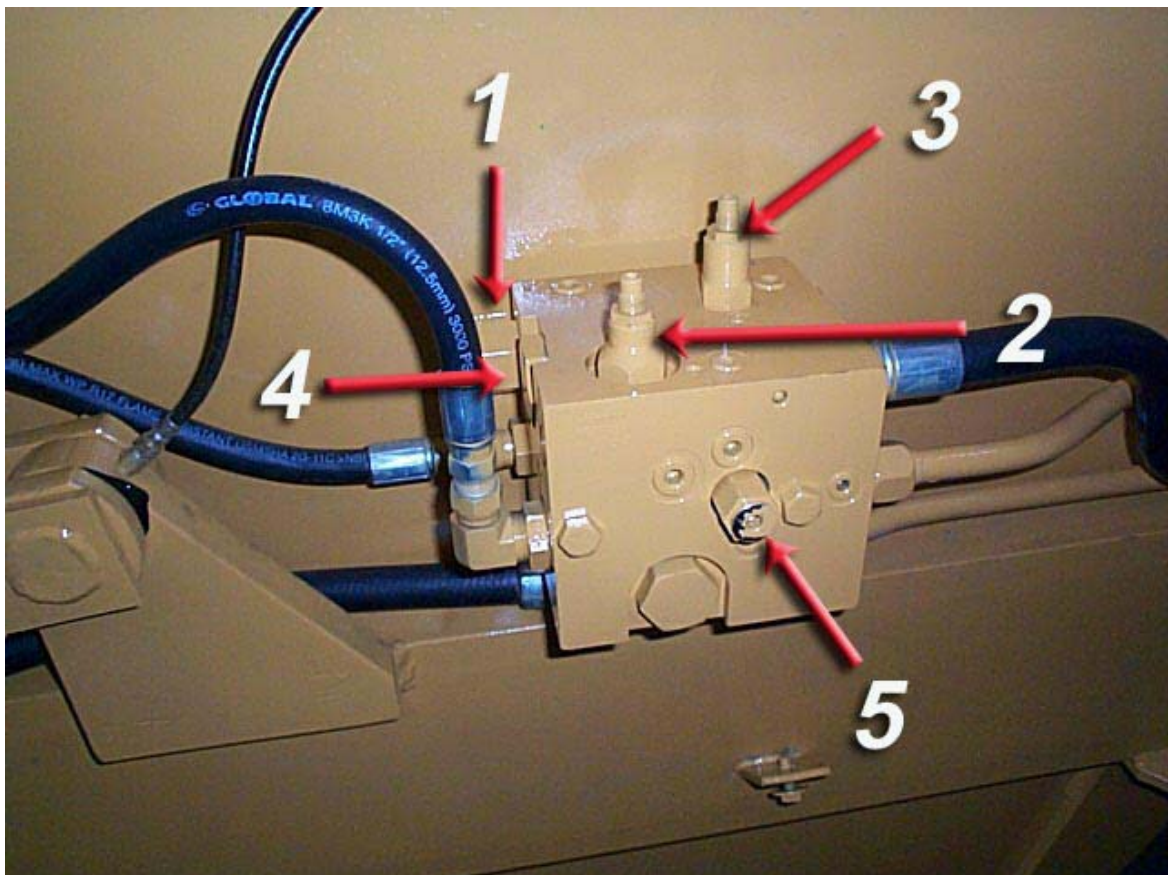

MAINTENANCE CHECKLIST

1. Grease all zerks.
 - a) Every 8 hours of operation.
 - b) See Lubrication Points section on following page.

2. Greasing the hubs.
 - a) Re-pack wheel bearings after 600 hrs of operation.
 - b) Completely clean grease out of hub and bearings every 1200 hours of operation.

3. Check tire pressure.
 - a) 20.5 - 25, 12-ply tire requires a tire pressure of 35-40 psi on a rear machine, 40-50 on a front machine.

4. Check all pins for signs of wear.
 - a) Daily

5. Check wheel lug nut torque.
 - a) After first 2 hours of operation.
 - b) Recheck daily for next 2 weeks.
 - c) Tighten wheel lug nuts in a star pattern.
 - d) Torque wheel lug nuts to 450 ft-lbs.

6. Check and retighten all bolts.
 - a) After initial 10 hours of use.
 - b) Again after 50 hours of use.
 - c) See Torque Specifications on following page.

7. Inspect cutting edges.
 - a) Daily
 - b) Replace cutting edges when center blade has been worn to approximately 6" and side edges worn to approximately 4".



CAUTION! Failure to replace worn cutting edges may result in unnecessary wear to the earthmover sides and floor.

Note: Please specify left or right "L" shaped cutting edges when ordering replacements.

TORQUE SPECIFICATIONS

| <i>Grade 8</i> | |
|-----------------|---------------|
| <i>Bolt</i> | <i>Torque</i> |
| <i>Diameter</i> | <i>ft-lbs</i> |
| 1/4" | 12 |
| 5/16" | 25 |
| 3/8" | 45 |
| 7/16" | 70 |
| 1/2" | 110 |
| 9/16" | 150 |
| 5/8" | 220 |
| 3/4" | 380 |
| 7/8" | 600 |
| 1" | 900 |
| 1-1/8" | 1280 |
| Lug Nuts | 750 |

LUBRICATION

1. Grease all zerks every 8 hrs of operation with high quality, general-purpose grease.
 - a) Grease until grease flows from around pin.

Lubrication Points (see *Ill. on next page*)

1. Hitch – Horizontal and vertical pins.
2. Lift Cylinders – Rod end & Trunion; Both left & right sides.
3. Front Arm Pivot Joint – Both left & right sides.
4. Apron Cylinders – Rod clevis pin; Both left & right sides.
5. Apron Pivot Pin – Both left & right sides.
6. Hold-down Rollers – Both left & right sides.
7. Floor Rollers – Both left & right sides.
8. Tapered Rollers – Both left & right sides.

Grease Locations

Grease Twice a Day

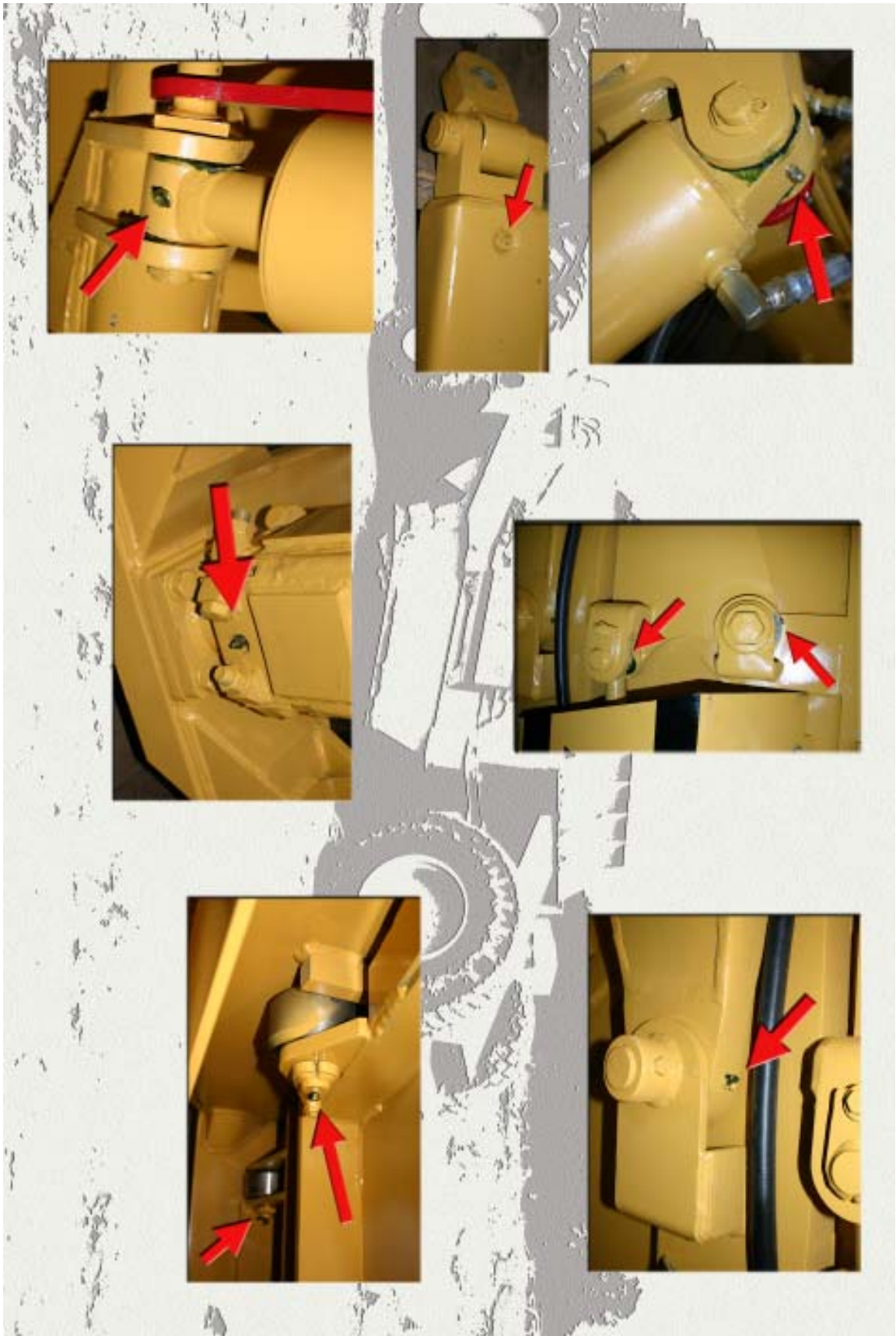

HYDRAULIC SYSTEM

Standard Two-Circuit Hydraulic Plumbing

The apron cylinders and the push-off cylinder are controlled on the same circuit with the sequence of the operation controlled by a sequence valve. The other hydraulic circuit controls the lift cylinders on the earthmover.

***To adjust the sequence valve, see Troubleshooting section.**

Optional Three-Circuit Hydraulic Plumbing

The apron cylinders, push-off cylinder, and lift cylinders are all on separate hydraulic circuits.

PUSHING THE EARTHMOVER

The I-130XL was designed to be pushed when equipped with the optional push-bar. However, Ashland Industries, Inc. **STRONGLY** recommends using extreme caution when pushing the I-130XL earthmover to prevent any unnecessary damage.



CAUTION! The I-130XL earthmover must be pushed in a straight line with a maximum of a 100 hp dozer. Do not ram or jar the earthmover while pushing and push at a constant speed.



TROUBLESHOOTING

Introduction

With proper care and maintenance, the I-130XL will give many years of reliable service. When a situation arises where the earthmover performance is not satisfactory, this section will give some pointers on finding and correcting the problem.

Grease zerk will not take grease.

1. Grease zerk plugged.
 - a) Remove and replace grease zerk.
2. Pin is frozen.
 - a) Remove, clean, and inspect pin.
 - b) Replace pin if necessary.
3. Bushing grease passage is not aligned with grease zerk.
 - a) Remove, clean, inspect, and realign bushing.
 - b) Replace bushing if necessary and realign.

Push-off rollers do not roll.

1. The rollers need lubrication.
 - a) Check zerk hole and grease.
 - b) Remove pin, clean, inspect, and replace if necessary.
2. The roller bushing is worn out.
 - a) Remove roller assembly and replace bushing.
 - b) See parts manual.

Cylinders will not hold in preset position, i.e. the cylinder creeps.

1. Seals leaking internally.
 - a) Remove and replace seal kit.

Limited Warranty Statement

Ashland Industries Inc. warrants each new product to be free from defects in material and workmanship. This warranty is applicable only for the normal service life expectancy of the product or components, not to exceed **six consecutive months** from the date of delivery of the new Ashland Industries product to the purchaser, or the date the product is first put into service via a rental agreement or other means, whichever occurs first.

The major components of swivel hitches used on Industrial series scrapers are warranted for three consecutive months from the date of delivery of the new Ashland Industries product to the purchaser, or the date the product is first put into service via a rental agreement or other means, whichever occurs first, except those components described below.

Genuine Ashland Industries Inc. replacement parts and components will be warranted for 30 days from date of purchase, or the remainder of the original equipment warranty period, whichever is longer.

Under no circumstances will it cover any merchandise or components thereof, which in the opinion of the company, has been subjected to misuse, unauthorized modification, alterations, an accident or if repairs have been made with parts other than those obtained through Ashland Industries Inc.

Ashland Industries Inc. in no way warrants Tires since their respective manufacturer warrants these items separately. Please call Ashland Industries Inc. to receive phone numbers of tire suppliers.

Ashland Industries Inc. in no way warrants wearable items such as cutting edges, front dolly wheel balls, socket halves, rollers, bushings, yoke hitch pins, hitch bushings, etc..

Our obligation under this warranty shall be limited to repairing or replacing, free of charge to the original purchaser, any part that, in our judgement, shall show evidence of such defect, provided further that such part shall be returned within 30 days from the date of failure to Ashland Industries Inc. routed through the dealer and distributor from whom the purchase was made, transportation charges prepaid. Upon warranty approval proper credits will be reimbursed for transportation.

This warranty shall not be interpreted to render Ashland Industries Inc. liable for injury or damages of any kind or nature to person or property. This warranty does not extend to the loss revenue, extra labor cost associated with downtime, substitute machinery, rental or for any other reason.

Except as set forth above, Ashland Industries Inc. shall have no obligation or liability of any kind on account of any of its equipment and shall not be liable for special or consequential damages.

Ashland Industries Inc. make no other warranty, expressed or implied, and, specifically, Ashland Industries Inc. disclaims any implied warrant or merchantability or fitness for a particular purpose. Some states or provinces do not permit limitations or exclusions of implied warranties or incidental or consequential damages, so the limitations or exclusion in this warranty may not apply.

This warranty is subject to any existing conditions of supply which may direct affect our ability to obtain materials or manufacture replacement parts.

Ashland Industries Inc. reserves the right to make improvements in design or changes in specifications at any time, without incurring any obligation to owners of units previously sold

No one is authorized to alter, Modify or enlarge this warranty nor the exclusion, limitations and reservations.

Ashland Industries Inc.

Warranty Department