

# Ashland

## EARTHMOVERS



# I-130TS2

## PARTS MANUAL

ver 6-06



Ashland Industries Inc.  
1115 Rail Drive  
P.O. Box 717  
Ashland, WI. 54806  
Ph: 877-634-4622 Toll Free  
Ph: 715-682-4622  
Fx: 715-682-9717  
[www.ashlandind.com](http://www.ashlandind.com)



### HOW TO ORDER PARTS:

#### **IMPORTANT**

Parts must be ordered through your local authorized ASHLAND dealer.

Be sure to state MODEL and SERIAL NUMBER of your machine, PART NUMBER, DESCRIPTION and QUANTITY needed.

Unless this is done, we cannot provide prompt service or assure shipment of the correct parts.



Ashland Industries weldable replacement parts are available to rebuild, modify or update your scraper to current factory specifications.

### **INDEX**

Page 3.	Safety Guidelines
Page 4.	Operators and Maintenance Instructions
Page 5.	Illustration and Parts List - Complete Yoke Type Hitch
Page 6.	Illustration and Parts List - Swivel Hitch
Page 7.	Illustration and Parts List - Front End Assembly
Page 8.	Illustration and Parts List - Apron Assembly
Page 9.	Illustration and Parts List - Bowl and Frame
Page 10.	Illustration and Parts List - Push Off Gate Assembly
Page 11.	Illustration and Parts List - Rear Wheel and Hub Assembly
Page 12-13	Illustration and Parts List - Apron Cylinder 4" X 13"
Page 14.	Illustration and Parts List - Lift Cylinder 5" x 16"
Page 15.	Illustration and Parts List - Push Off Cylinder 4-1/2" x 54"
Page 16-21	Illustration, Parts List and Adjustment - Sequence Valve
Page 22-26	Service Manual Appendix
Page 27-28	Troubleshooting
Page 29.	Warranty Statement



## SAFETY SIGNAL WORDS

Note the use of the signal words DANGER, WARNING and CAUTION with the safety messages. The appropriate signal word for each has been selected using the following guidelines:

**DANGER:** Indicates an imminently hazardous situation that, if not avoided, will result in death or serious injury. This signal word is to be limited to the most extreme situations typically for machine components which, for functional purposes, cannot be guarded.

**WARNING:** Indicates a potentially hazardous situation that, if not avoided, could result in death or serious injury, and includes hazards that are exposed when guards are removed. It may also be used to alert against unsafe practices.

**CAUTION:** Indicates a potentially hazardous situation that, if not avoided, may result in minor or moderate injury. It may also be used to alert against unsafe practices.



## GENERAL SAFETY GUIDELINES

Safety of the operator is one of the main concerns in designing and developing a new piece of equipment. Designers and manufacturers build in as many safety features as possible. However, every year many accidents occur which could have been avoided by a few seconds of thought and a more careful approach to handling equipment. You, the operator, can avoid many accidents by observing the following precautions in this section. To avoid personal injury, study the following precautions and insist those working with you, or for you, follow them.

Replace any CAUTION, WARNING, DANGER or instruction safety decal that is not readable or is missing. Location of such decals is indicated in this booklet.

Do not attempt to operate this equipment under the influence of drugs or alcohol.

Review the safety instructions with all users annually.

This equipment is dangerous to children and persons unfamiliar with its operation. The operator should be a responsible adult familiar with farm machinery and trained in this equipment's operations. **Do not allow persons to operate or assemble this unit until they have read this manual and have developed a thorough understanding of the safety precautions and of how it works.**

To prevent injury or death, use a tractor equipped with a Roll Over Protective System (ROPS). Do not paint over, remove or deface any safety signs or warning decals on your equipment. Observe all safety signs and practice the instructions on them.

Never exceed the limits of a piece of machinery. If its ability to do a job, or to do so safely, is in question - **DON'T TRY IT.**

# OPERATORS AND MAINTENANCE INSTRUCTIONS

This scraper is a durable piece of equipment and with proper care will yield many years of trouble free operation. The scraper requires a power source with TWO 4 way (double acting) hydraulic control valves.

The scraper should be greased at all points where grease fittings are provided. Connect hydraulic hoses to the tractor and retract lift cylinders to **REMOVE TRANSPORT LOCK PINS** (point A), then extend and retract all cylinders several times to force out any air from the hydraulic cylinders and lines. Check the oil levels in the tractor hydraulic system and add to maintain the proper level. Care should be used when adding oil or when disconnecting any oil line to keep all dirt out of the oil as dirt is a major factor in the failure of hydraulic components.

When the scraper is placed into operation, the operator will have to "feel out" the amount of depth of cut to obtain maximum loading efficiency. This is usually accomplished by taking a lesser and more uniform cut; however, some soil conditions such as loose sand may require a "pumping action" obtained by taking successive deep cuts and lifting out of cut as the tractor begins to lose power or traction.

1. After 10 hours work, all bolts should be checked and tightened if necessary.
2. Every 10 hours all grease fittings should be lubricated.
3. After 50 hours work, all bolts should be rechecked and tightened if necessary. Check wheel bearings and adjust if necessary.
4. After 300 hours work, clean and repack wheel bearings and replace, if necessary, cutting edges, worn pins, etc.
5. Tighten all wheel bolts after first two hours use. Check daily for two weeks. Keep torqued to 450 ft. lbs.
6. Maintain tire pressure at 35 to 40 psi on a rear unit, 40 to 50 on a front unit.

# SWIVEL HITCH ASSEMBLY

## I-130 TS2

### A125223

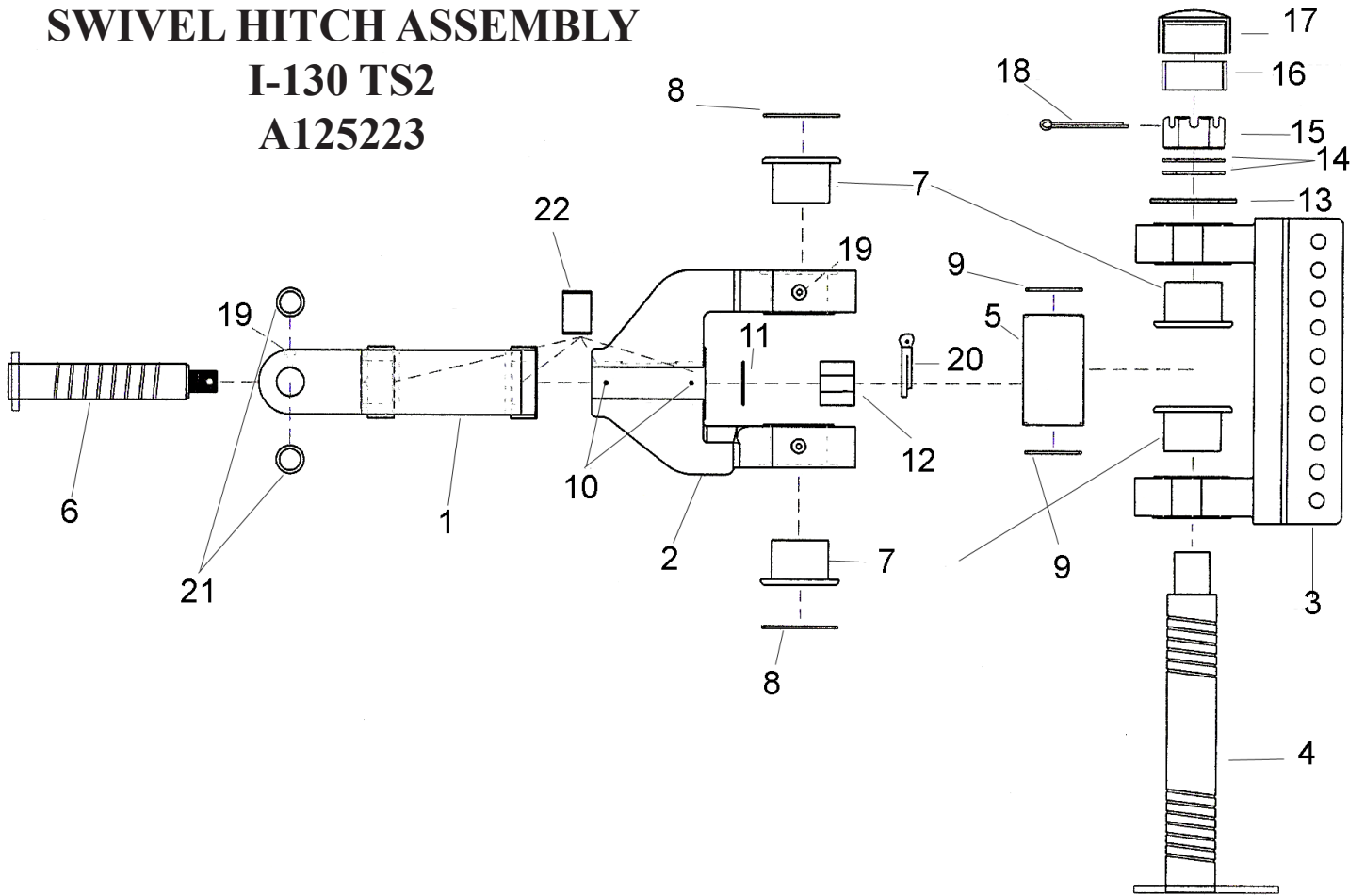

KEY #	PART NUMBER	QUANTITY REQUIRED	DESCRIPTION
1	A125223-01	1	Yoke: A-Frame
2	A125223-02	1	Swivel
3	A125223-03	1	Bracket: 10 Hole
4	A125223-04	1	Pin: Main Vertical
5	A125223-05	1	Spacer: 6"
6	A125223-06	1	Pin Horizontal
7	A125223-07	4	Bushing
8	A125223-08	2	Seal: O-ring
9	A125223-09	2	Seal: O-ring
10	AFH-00028	2	Grease Fitting: 90°
11	A125223-11	2	Washer- 1-1/2" For Horizontal Pin
12	A125223-12	1	Nut: Slotted 1-1/2" NC
13	A125223-13	1	Spacer: 6"
14	A125223-14	2	Washer: 2 1/2"
15	A125223-15	1	Nut: Slotted 2-1/2" NC
16	A125223-16	1	Sleeve: 2" Rubber
17	A125223-17	1	Cap: For Vertical Pin
18	A125223-18	1	Pin: Cotter 3/8 x 5"
19	14505	4	Grease Fitting Straight
20	8613	1	Cotter Pin: 5/16 x 2-1/2"
21	A125056-24	2	Bushing
22	A125056-27	2	Bushing

FRONT END

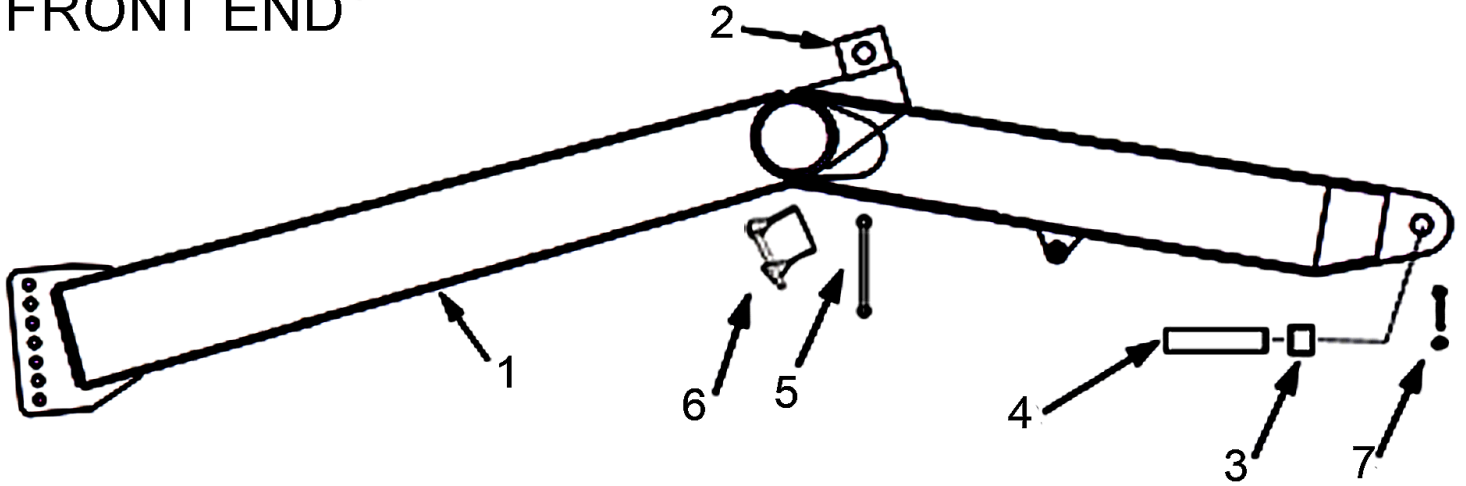

**KEY NO.**

**PART NO.**

**DESCRIPTION**

1.	A123292	Front End Assembly
2.	A123293A	Trunion Mount Block
3.	A14039	Bushing, 2-3/8" OD x 2" ID x 2" Long with Grease Passage
4.	A10152A	Frame Attachment Pin, 2" x 8-1/16"
5.	A123292-17	Travel Lock
6.	A125006	Safety Snap Pin
7.	AFB-00054	Bolt: 1/2" x 3-1/2" w/7500 Nut

## I-130TS APRON ASSEMBLY

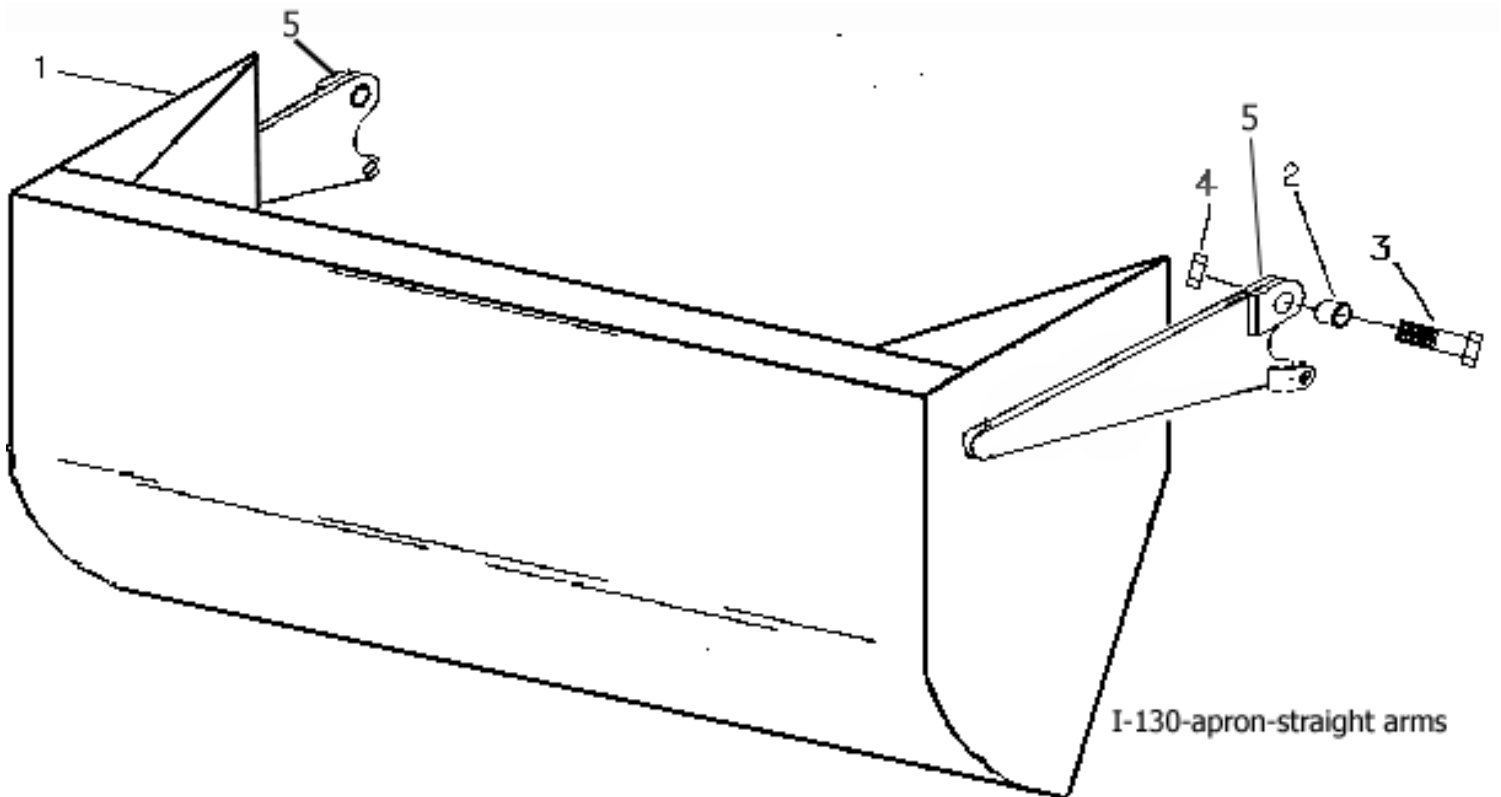

KEY NO.	PART NO.	DESCRIPTION
1	A123341	Apron
2	A123343	Bushing: 2" OD X 1-1/2" ID x 1-3/4" Long
3	AFB-00038	Bolt, 1-1/2" NF x 5-1/2" long
4	AFN-00018	Nut, Self lock 1-1/2" NF
5	14505	Grease fitting



# BOWL & FRAME ASSEMBLY

## BOWL AND FRAME ASSEMBLY

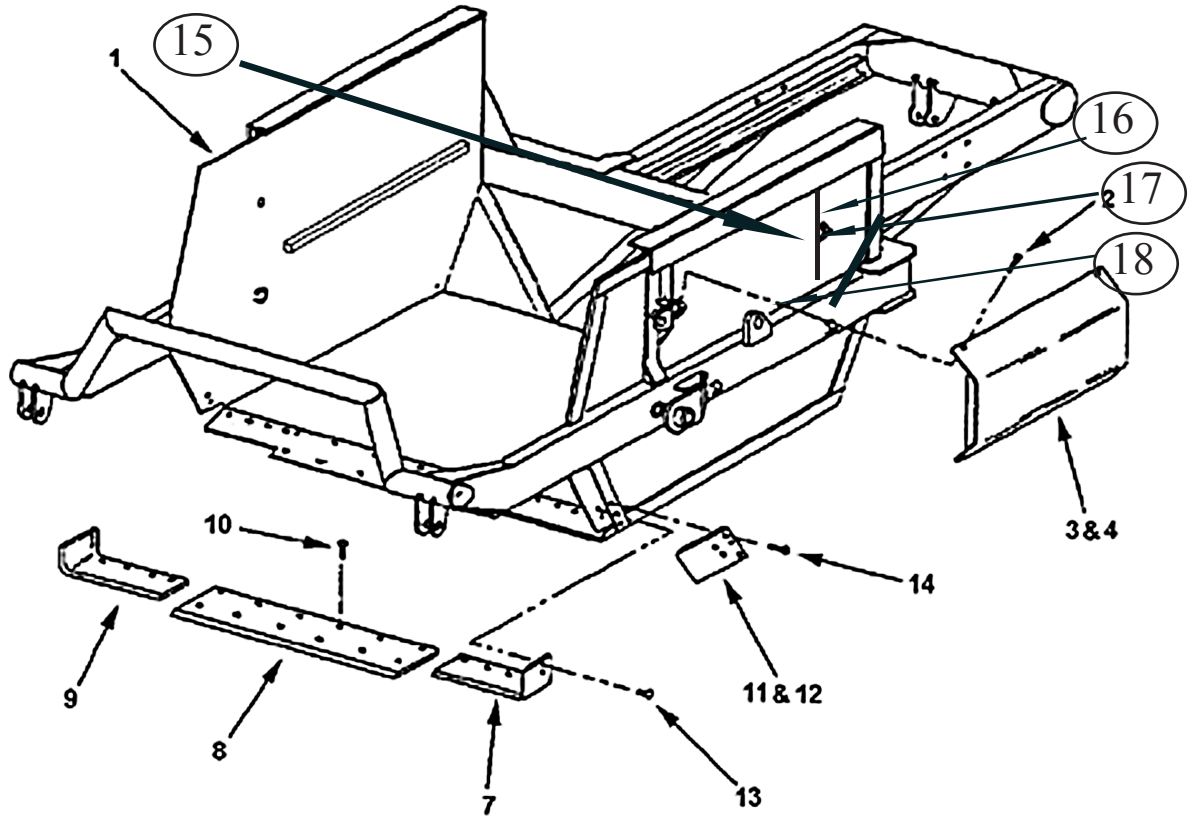

110-130 bowl

KEY NO.	PART NO.	DESCRIPTION
1	A123325	Bowl and Frame I-130TS
2	AFB-00094	Flange Bolt, 3/8" NC x 1"
3	A10157	Left hand cylinder guard
4	A10158	Right hand cylinder guard
7	A123332L	Left cutting edge, 8"
8	A123331	Center cutting edge, 12" x 54"
9	A123332R	Right cutting edge, 8"
10	PB9P-NC-088-0275	Plow bolt, 7/8" NC x 2-3/4" (12 req'd.)
	AFN-00019	Nut: 7/8" NC (12 req'd./ center blade)
11	A123338L	(Optional) Left Bank Shaver Side Blade
12	A123338R	(Optional) Right Bank Shaver Side Blade
13	PB9P-NC-088-0275	Plow bolt, 7/8" NC x 2-3/4" (6 req'd./ corner blade)
	AFN-00019	Nut: 7/8" NC (6 req'd./ corner blade)
14	PB9P-NC-088-0275	Plow bolt, 7/8" NC x 2-3/4" (4 req'd./ shaver blade)
	AFN-00019	Nut: 7/8" NC (4 req'd./ shaver blade)
	PB9P-NC-088-0225	Plow bolt, 7/8" NC x 2-1/4" (3 req'd./ shaver blade)
	AFN-00026	Nut: 7/8" NC Jam (3 req'd./ shaver blade)
15	A125019	Grease fitting 1/4-28 x .54" long (1 per side)
16	A125026	Bulkhead nut 1/8 n.p.s.m. (1 per side)
17	A123309-89	Single hole tab (1 per side)
18	A125022	18" Grease line (1 per side)



# PUSH OFF GATE ASSEMBLY

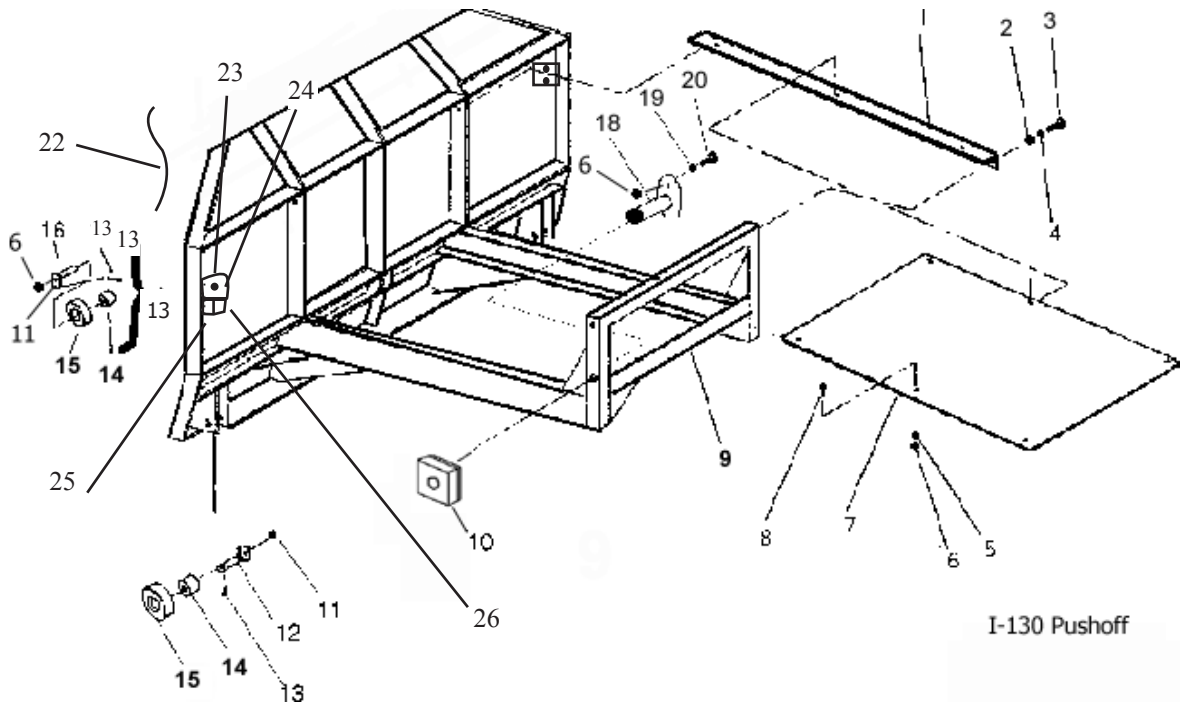

<b>KEY NO.</b>	<b>PART NO.</b>	<b>DESCRIPTION</b>	<b>QTY</b>
1.	A10159	Brace (L.H. & R. H. same)	
2.	AFN-00006	Nut: 3/4" NC	
3.	AFB-00037	Bolt: 3/4" NC x 2" Lg.	
4.	AFW-00002	Lockwasher: 3/4"	
6.	7500	Nut: 1/2" NC	
7.	A10171	Dirt Shield	
8.	AFB-00019	Bolt: 1/2" x 1-1/2" NC Bolt	
9.	A16024	Pushoff Gate: Model I-130	
10.	A123306	Roller: Rear Gate	
	A123307	Bushing" 1-5/8" OD x 1-1/4" ID	
10B.	A123305A	Pin: 1-1/4" x 2-3/4"	
10C.	A123353	Wear pad	
11.	AHF-00028	Grease Fitting: 1/8" NPT -90 degree	
12.	A6007A	Pin: 1-1/4" x 4-1/8" Lg.	
13.	AFP-00001	Cotter Pin: 1/4 X 3-1/2"	
14.	A10163	Bushing: 1-3/4" OD x 1-1/4" ID	
15.	A123459	V-Roller: 4-1/4 OD X 1-3/4 ID	
16.	A123323	Pin: 1-1/4 X 4 1/8" Tab Head	
17.	A10163	Bushing: 1-3/4" OD x 1-1/4" ID	
18.	A10164	Roller: 4-1/4 OD X 1-3/4 ID	
19.	A123305	Pin: 1-1/4 X 2-3/4" w/grease for Roller	
20.	8100	Lockwasher: 1/2"	
21.	AFB-00033	Bolt: 1/2 NC X 2-1/2"	
22.	A125020	32" grease line	2
23.	A123323-40	Double hole tab	2
24.	A125026	Bulkhead Nut	4
25.	A125021	54" greaseline	2
26.	A125019	grease fitting 1/4-28 .54" long	2

## REAR WHEEL, SPINDLE & HUB ASSEMBLY

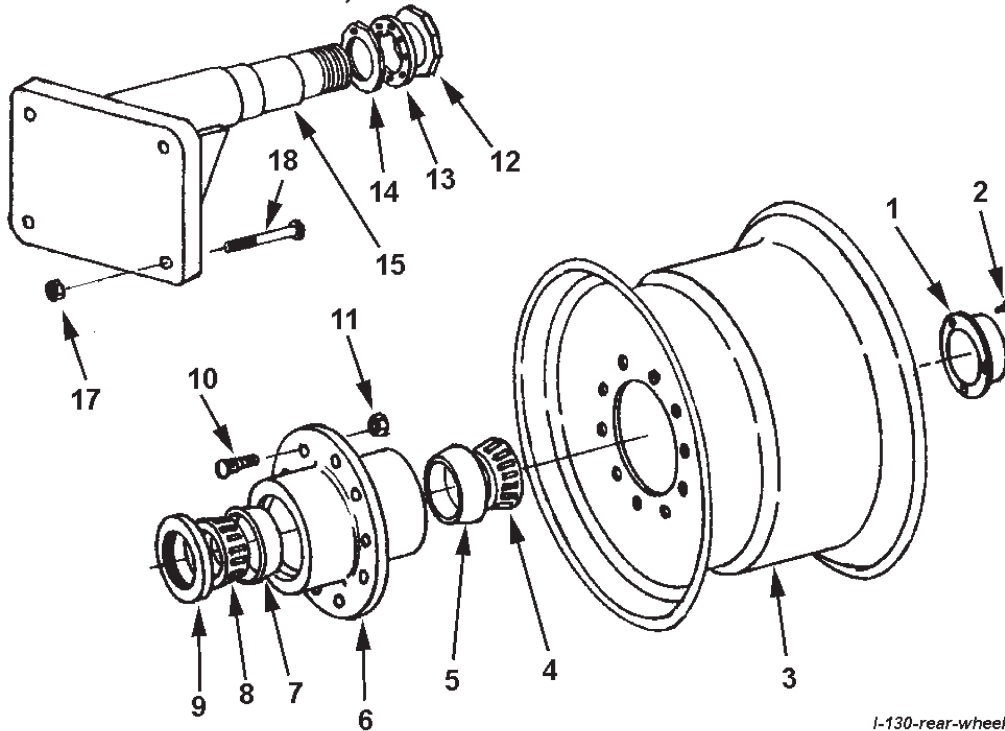

I-130-rear-wheel

<u>KEY NO.</u>	<u>PART NO.</u>	<u>DESCRIPTION</u>
1	A14035	Wheel - 17" x 25"
2	A14008	O-Ring
3	A14038	Lock Ring
4	A14015	Bearing cone (Timken 644)
5	A14014	Bearing cup (Timken 632)
6	A14010	Hub
7	A14013	Bearing cup (Timken 742)
8	A14012	Bearing cone (Timken 749)
9	A14011	Grease seal (CR 42624)
10	A10176	Stud
11	A10046	Lug nut
12	A10048	Spindle nut
13	A10049A	Lock collar
14	A10172	Nut w/ lock pin
15	A14037	Spindle
16	AFN-00001	Nut, 1" NF Toplock
17	AFB-00017	Bolt, 1" NF x 6-1/2" lg.
18	A14036	Slide Ring
19	A14016	Valve Stem
20	A14004	Hub Cap
21	8070	Lockwasher, 5/16"
22	AFB-00080	Bolt, 5/16" NC x 1/2" lg.
23	A14037E	Extended spindle plate (Option)
24	A14037P	Cross pipe
25	AFB-00092	Bolt: 1" NFX 4 Lg, 8 Reg
26	AFN-00001	Nut: 1" NF Top Lock, 8 Reg

# APRON CYLINDER 4"x13"

## Part #A125050

### s.n. 20750 and above effective 06/03

If you have 3 capscrew headcap refer to the next page.

**1\* OLD STYLE**

The older apron cylinder can be identified by 3/8" NPT ports & 3 bolts on the headcap of the gland.

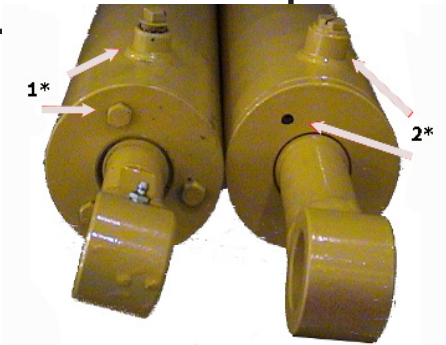

**2\* NEW STYLE**

The new style, effective 6/25/03, has 7/8" o-ring base ports & the gland is threaded into I.D. of the barrel. Identified by the 2 holes on the end of the cylinder.

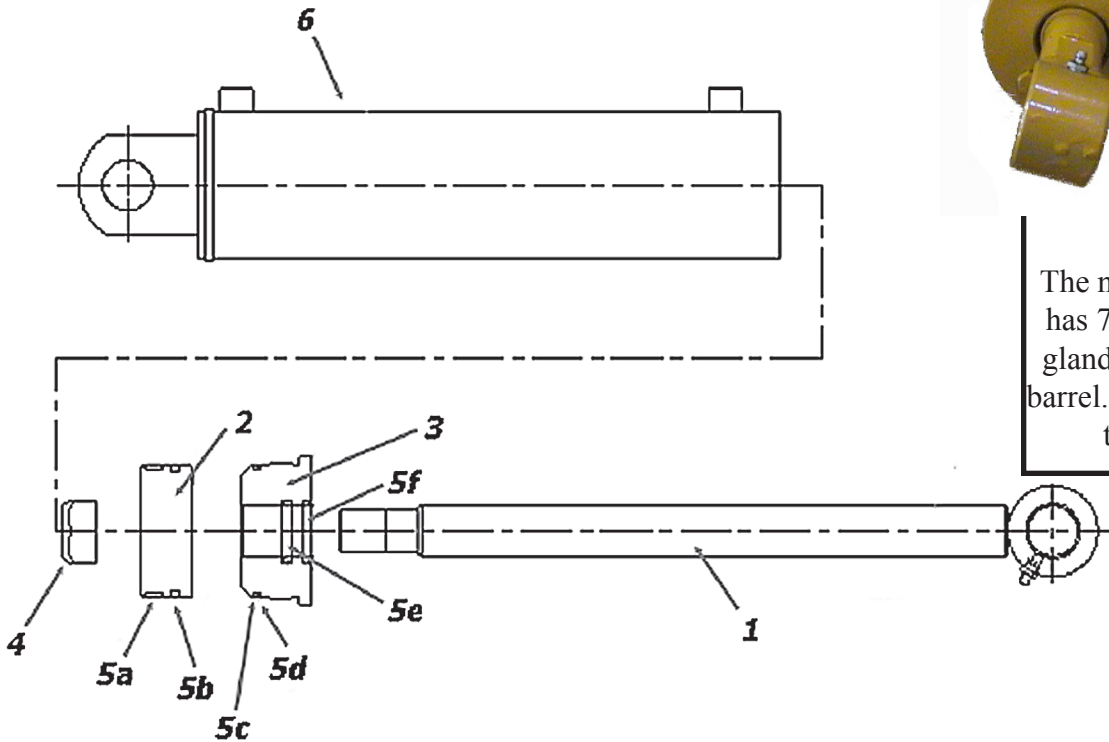

<u>ITEM</u>	<u>PART ITEM</u>	<u>DESCRIPTION</u>
1	A125050-01	Rod 1-3/4" with welded eye
2	A125050-02	Piston
3	A125050-03	Gland, Threaded
4	A125050-04	Lock Nut, 1-1/8" NF
5	A125050-05	Seal Kit, a-f
	A125050-05a	Nylon Wear Ring
	A125050-05b	FSP Seal
	A125050-05c	O-Ring
	A125050-05d	Backup Washer
	A125050-05e	Hallite Rod Seal
	A125050-05f	Snap-in Rod Wiper

# HYDRAULIC CYLINDER

# 4" x 13" APRON CIRCUIT A123319 upto s.n. 20749

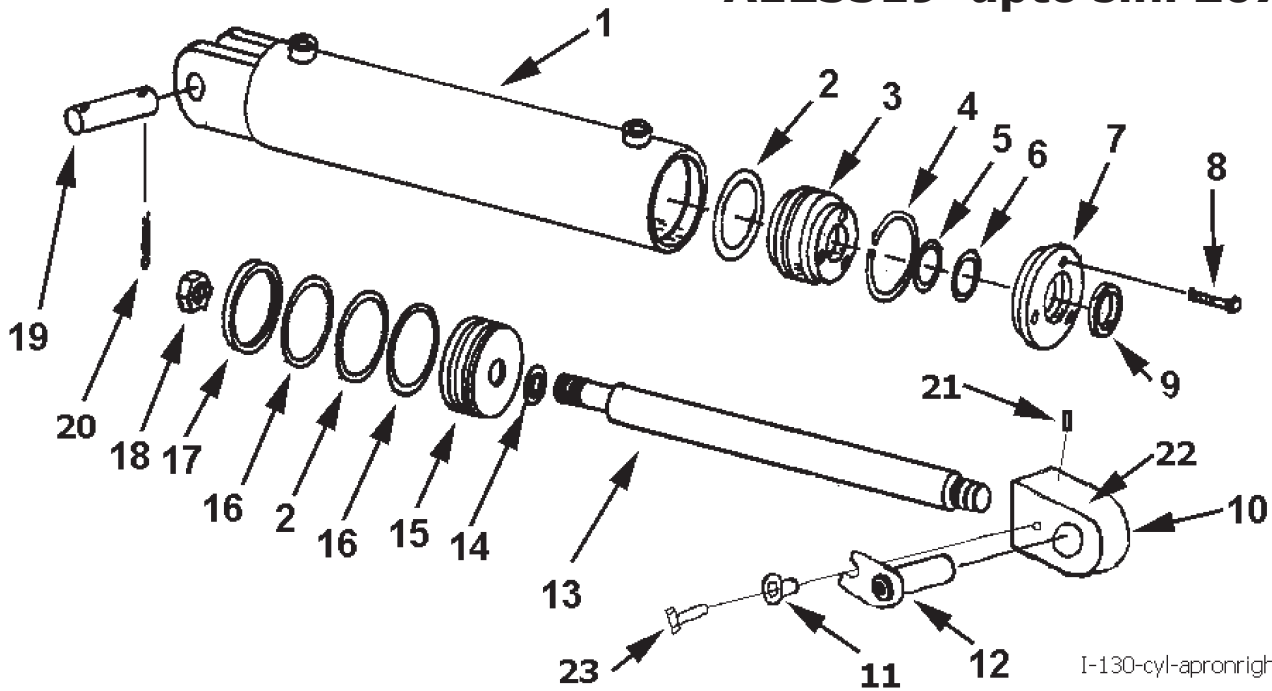

I-130-cyl-apronright

KEY NO.	PART NO.	DESCRIPTION
1	A175H01	Barrel Assembly
2	A300H06	O-ring seal, 4" OD x 3/16"
3	A300H11	Head gland
4	A300H12	Retainer ring
5	A22H15	O-ring, 1-1/2" x 1/8"
6	A22H15A	Backup washer
7	A300H13	Head cap
8	A22H18	Capscrew, 1/4 NC x 1"
9	A22H17	Wiper seal, 1-1/2" ID
10	A123345	Block type apron cyl., rod end cyl. 1"
11	A123351	Pin keeper bushing
12	A123336	Pin: Tab Head
13	A175H02	Shaft, 1-1/2" diameter
14	A45H05	Piston gasket, 1"
15	A300H07	Piston, 4" dia.
16	A300H05	Back up washer, 4" OD
17	A300H04	Cast iron ring, 4" OD
18	A300H03	Piston nut, 1" NF
19	A1217E	Pin, 1" x 3-1/2" w/tab head
20	8602	Cotter pin
21	AFB-00062	Allen set screws
22	14505	Grease fitting
23	AFB-00015	Bolt, 1/2" x 1-1/2" NC
	A300H14B	Packing kit containing:
		1 - A300H04    2 - A22H15    2 - A300H05
		1 - A22H15A    2 - A22H06    1 - A22H17
		1 - A45H05

**LIFT CYLINDER  
5" x 16" TRUNION MOUNT  
PART NO. A123324**

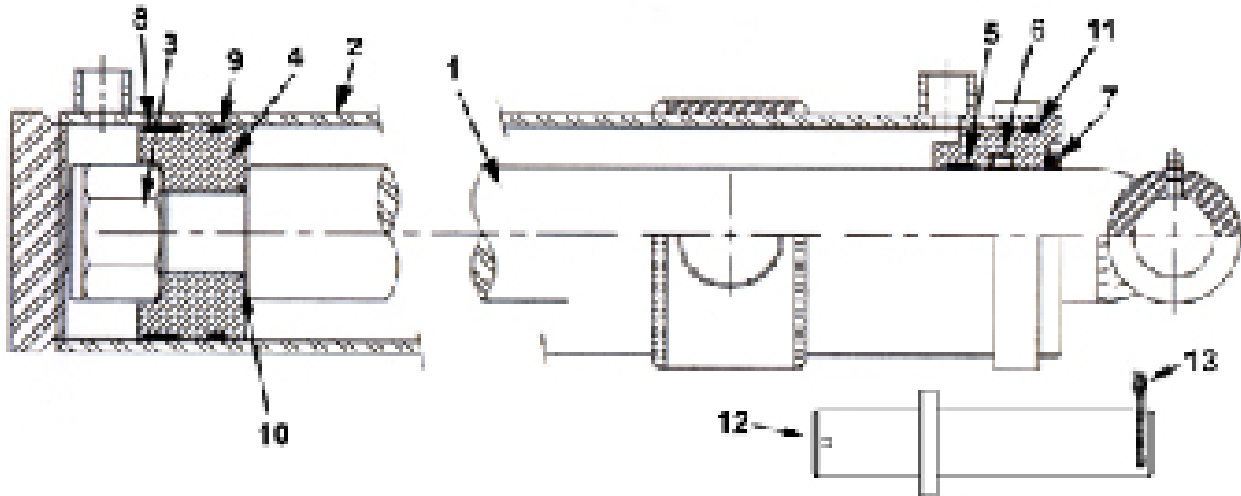

KEY NO.	PART NO.	DESCRIPTION
1	A123324-1	2-1/2" Rod
2	A123324-2	Barrel Weldment
3	A123324-3	Lock Nut 1-1/2"-12
4	A123324-4	Piston
5	A123324-5	Gland
6	A123324-6	Rod Seal
7	A123324-7	Rod Wiper
8	A123324-8	Wear Ring
9	A123324-9	Piston Seal (2-pc.)
10	A123324-10	O-ring
11	A123324-11	O-ring
	AHS-00140	Seal Kit (Items 6-11)
12	A123381	Pin 1-1/2" x 10-3/4
13	AFP-00001	1/4" x 3" Cotter Pin

# I-130 PUSH GATE CYLINDER ASSEMBLY

PART NO. A455H114

4 1/2" BORE X 54" STROKE - MODEL I-130 (SERIAL NO. 17870 & UP)

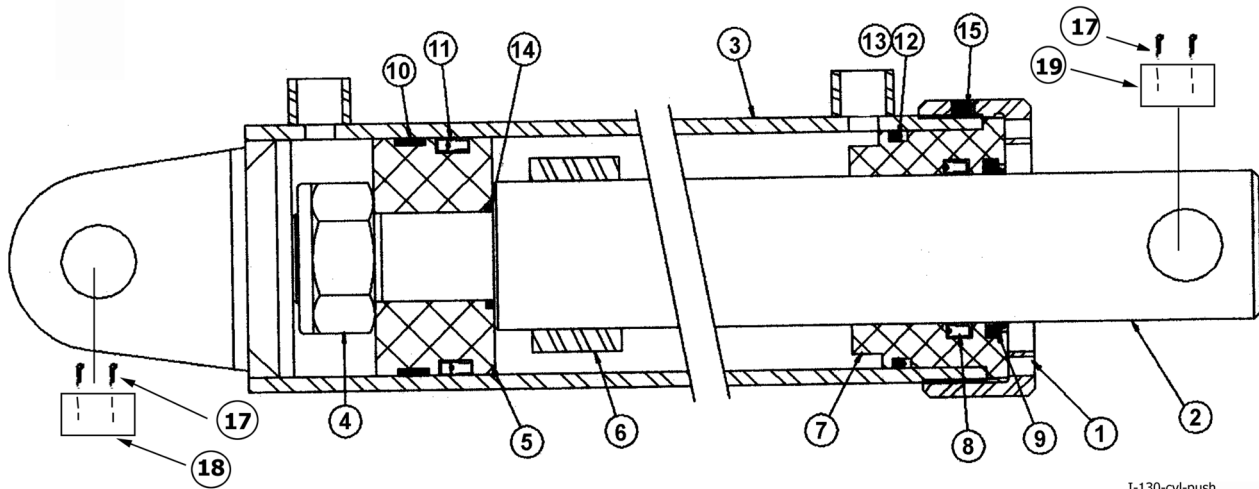

I-130-cyl-push

<u>KEY NO.</u>	<u>PART NO.</u>	<u>DESCRIPTION</u>
1	A175H10	Collar
2	A130H30	2 1/2" Rod
3	A130H29	Barrel weldment
4	A140H13	Lock nut (2" - 12)
5	A175H12	Piston
6	A17506	Spacer
7	A175H09	Head
8	A140H07	Rod seal
9	A140H08	Rod wiper
10	A175H07	Wear ring
11	A175H05	Piston seal
12	A175H03	O-ring
13	A175H04	Backup ring
14	A22H15	O-ring
15	AFB-00061	Nylon tip set screw (3/8" NC x 3/8)
16	A175H15	Seal kit (Items 8-14)
17	8602	Cotter pin, 1/4" x 2"
18	A9024	Pin, 1-1/4" diameter x 4-3/4" long
19	A14033	Pin, 1-1/4" diameter x 5" long

# I-130 Push Gate Cylinder Assembly

## Part Number A125176

### 4 1/2" BORE X 54" STROKE

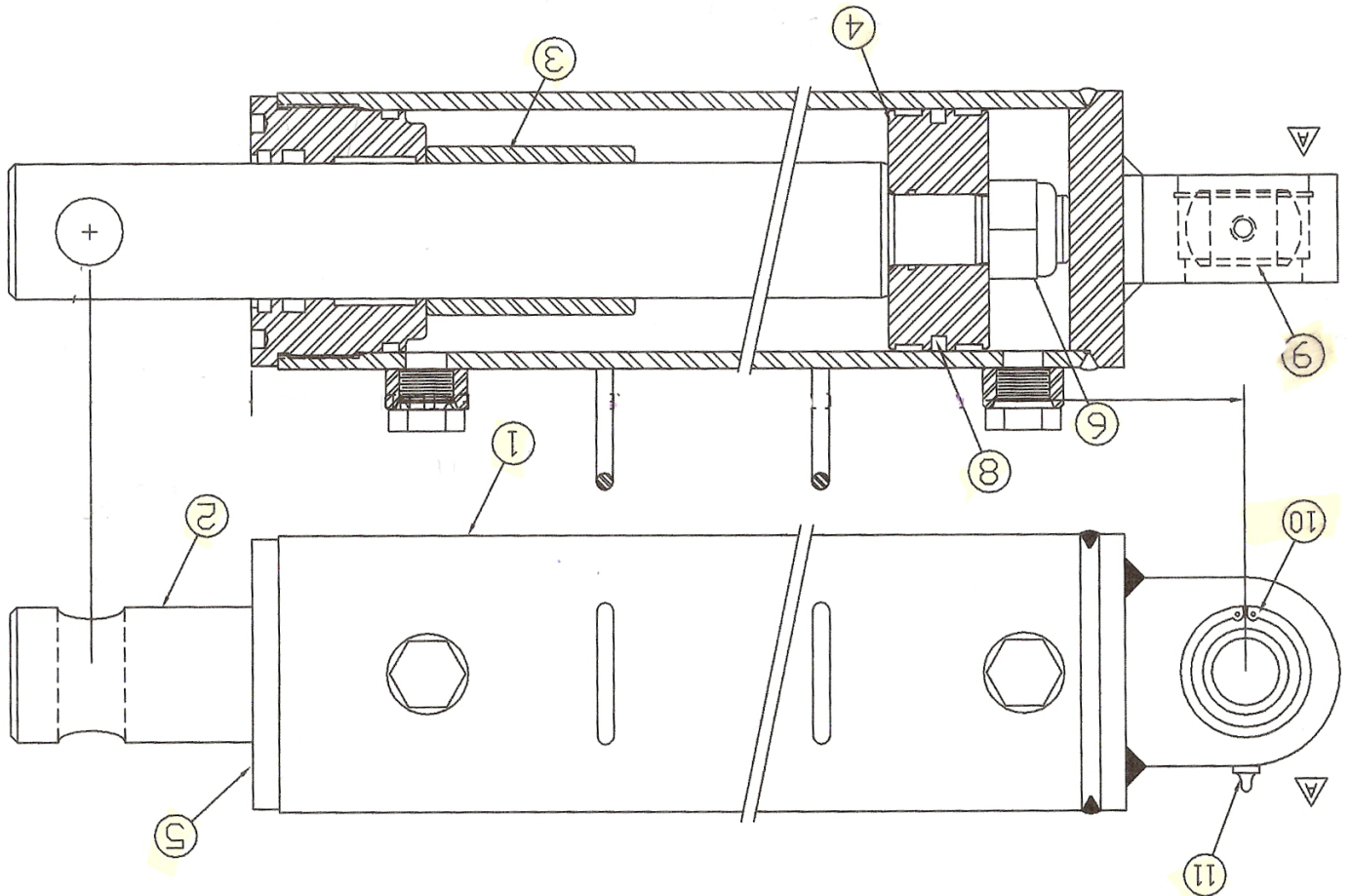

<u>KEY NO.</u>	<u>PART NO.</u>	<u>DESCRIPTION</u>
1.	A125176-10	Barrel Weldment (1)
2.	A125176-20	Shaft (1)
3.	A125176-32	Spacer (1)
4.	A125176-30	Piston (1)
5.	A125176-31	Head (1)
6.	A125175-33	1 1/4" Nylock Nut (1)
8.	A125176-40	Seal Kit (1)
9.	A125175-35	Bearing
10.	A125175-36	Snap Ring
11.	A125175-37	Grease Zerk (1)



# HYDRAULIC VALVE IDENTIFICATION



New Valve



Old Valve

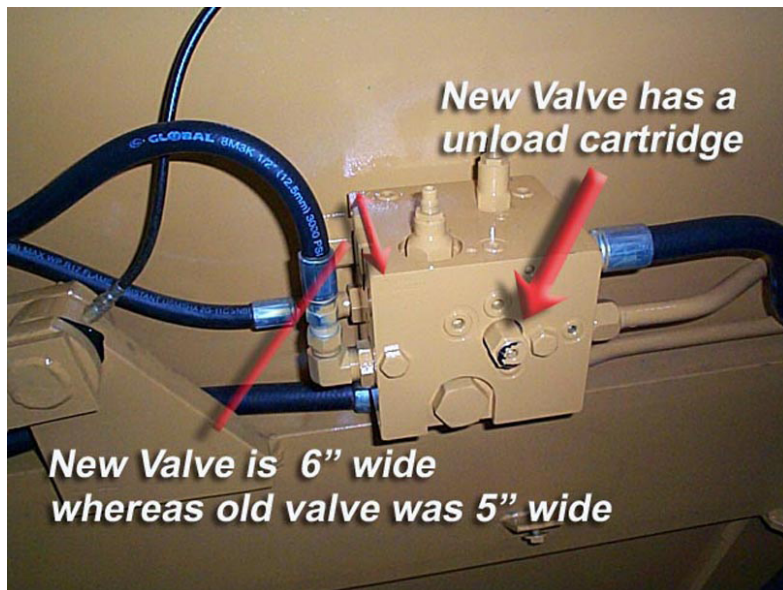

Visually there are several things you can check to ensure you have the correct valve. The new valve (shown on the left) is 6'' wide whereas the older valve (shown below) was 5'' wide. The new valve utilizes a unload cartridge that sticks outward on the side of the valve.



**IMPORTANT:** This Hyd. Manifold was intergrated into production Nov. 2003 It replaces A125055 valve which was used on S.N. 20750 to 20853. To confirm which valve you have, confirm with earlier valve I.D. page

**HYDRAULIC MANIFOLD ASSEMBLY  
A125070  
S.N. 20853 & above**

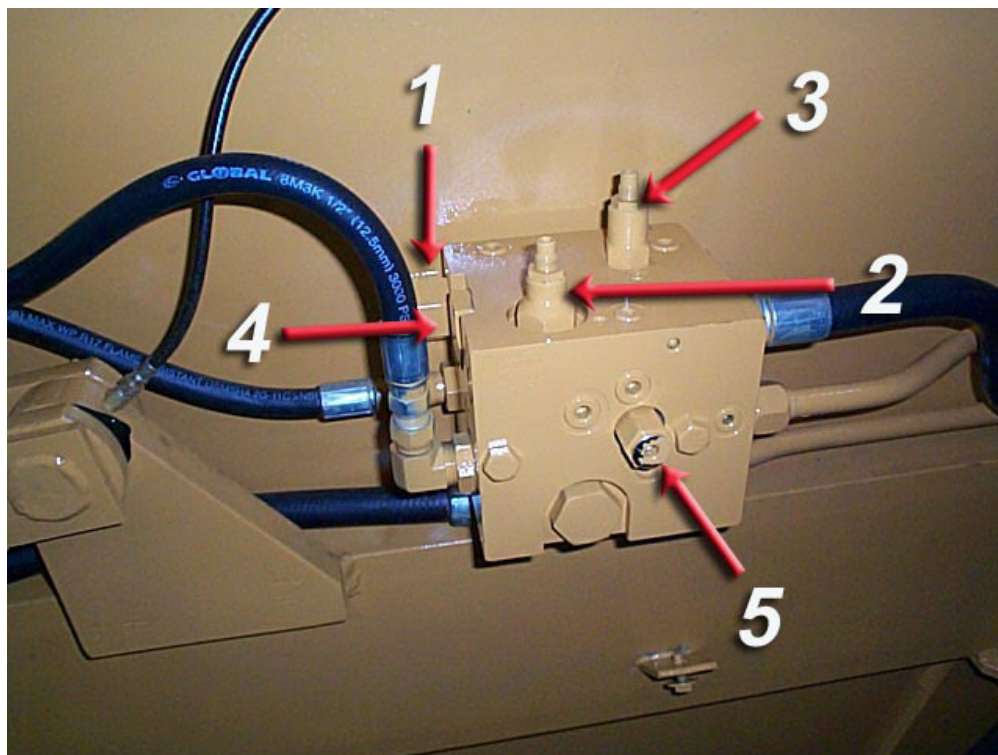

<u>ITEM #</u>	<u>PART NO.</u>	<u>DESCRIPTION</u>
1	A125070-01	DIRECTIONAL CONTROL VALVE
2	A125070-02	APRON SEQUENCE CARTRIDGE
3	A125070-03	PUSHOFF SEQUENCE CARTRIDGE
4	A125070-04	CHECK VALVE CARTRIDGE
5	A125070-05	UNLOAD CARTRIDGE



## SETTING THE APRON AND PUSHOFF VALVE

The manifold block containing the pushoff sequence valve cartridge and apron sequence valve cartridge is used to control two hydraulic circuits with one hydraulic remote. When the tractor hydraulic remote is activated, oil flows first to the apron cylinders until they are fully extended. Once the cylinders are fully extended, the apron circuits' hydraulic pressure begins to increase. Once the pressure threshold is surpassed (which is adjustable. See adjustment section), the sequence valve diverts the oil flow to the pushoff's hydraulic circuit. Once the push off is completely extended the operator then reverses the tractor's hydraulic remote. The counterbalance valve will hold the apron open until the push off is fully retracted. The Apron sequence valve then opens and allows the apron to close.

### Setting the valves:

#### STEP 1 PUSHOFF SEQUENCE VALVE

Loosen the lock nut (3/4") on the sequence valve cartridge. Turn the setscrew (1/4") clockwise until the front apron rises before the push-off begins to advance. (Earth-mover should be empty) Turn the adjustment screw an additional 1/4 turn clockwise and tighten jam nut.

#### STEP 2 APRON SEQUENCE VALVE

Loosen the lock nut (3/4") on the counterbalance valve cartridge. Turn the setscrew (4 mm) clockwise until the apron holds in a raised position while rear gate is being retracted. Turn adjustment screw an additional 1/4 turn, tighten jam nut. DO NOT tighten adjusting screw more than necessary.

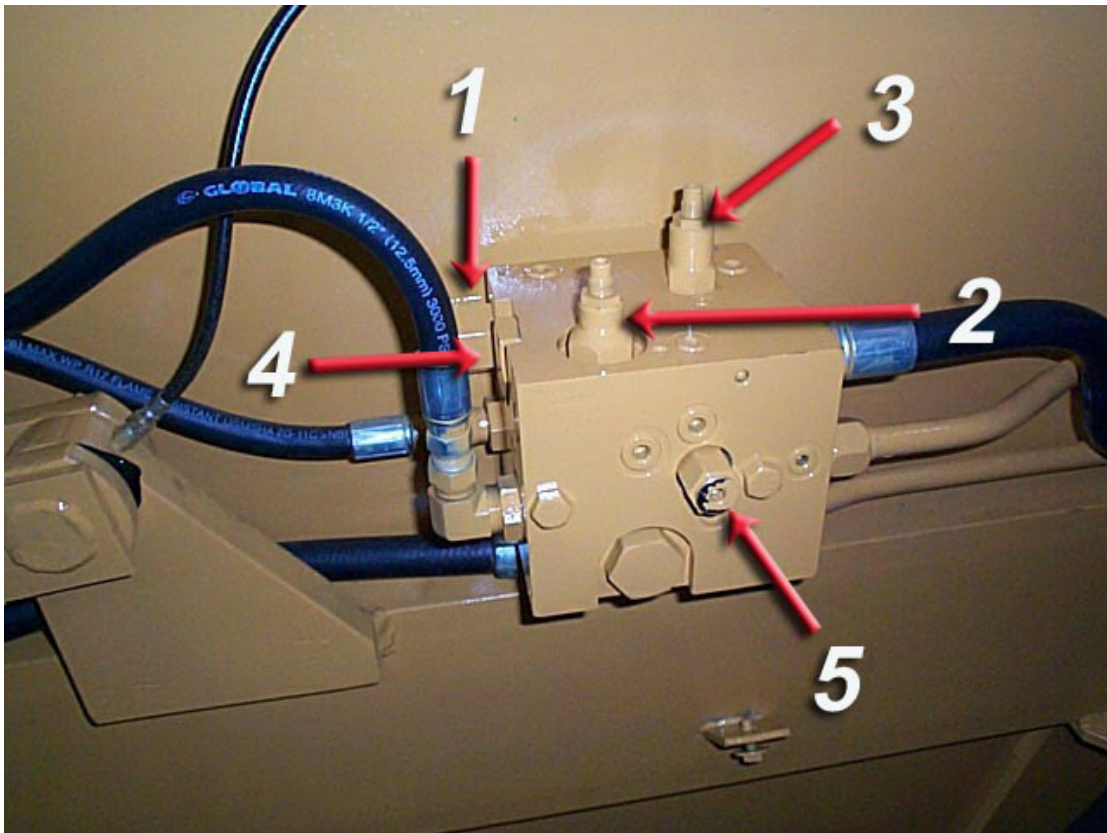

**IMPORTANT:** This Hyd. Manifold has been replaced by A125070 on Nov 2003. To confirm which valve you have, confirm with earlier valve I.D. page

**HYDRAULIC MANIFOLD ASSEMBLY  
A125055  
S.N. 20750 to 20853**



<b><u>ITEM #</u></b>	<b><u>PART NO.</u></b>	<b><u>DESCRIPTION</u></b>
1	A125055-01	DIRECTIONAL CONTROL VALVE
2	A125055-02	COUNTER BALANCE CARTRIDGE
3	A125055-03	SEQUENCE CARTRIDGE
4	A125055-04	CHECK VALVE
5	A125055	COMPLETE ASSEMBLY WITH ALL VALVES

# SEQUENCE VALVE

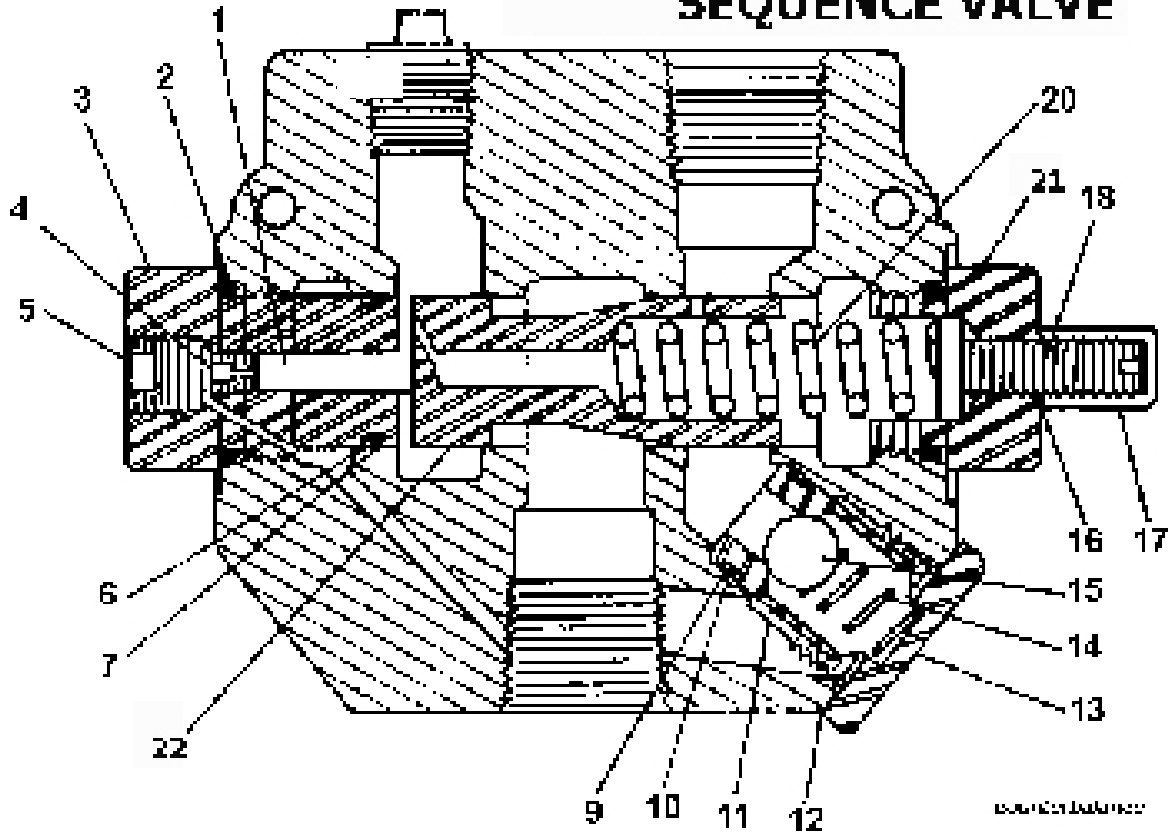

SEQUENCE VALVE PART #A101H47

# COUNTERBALANCE

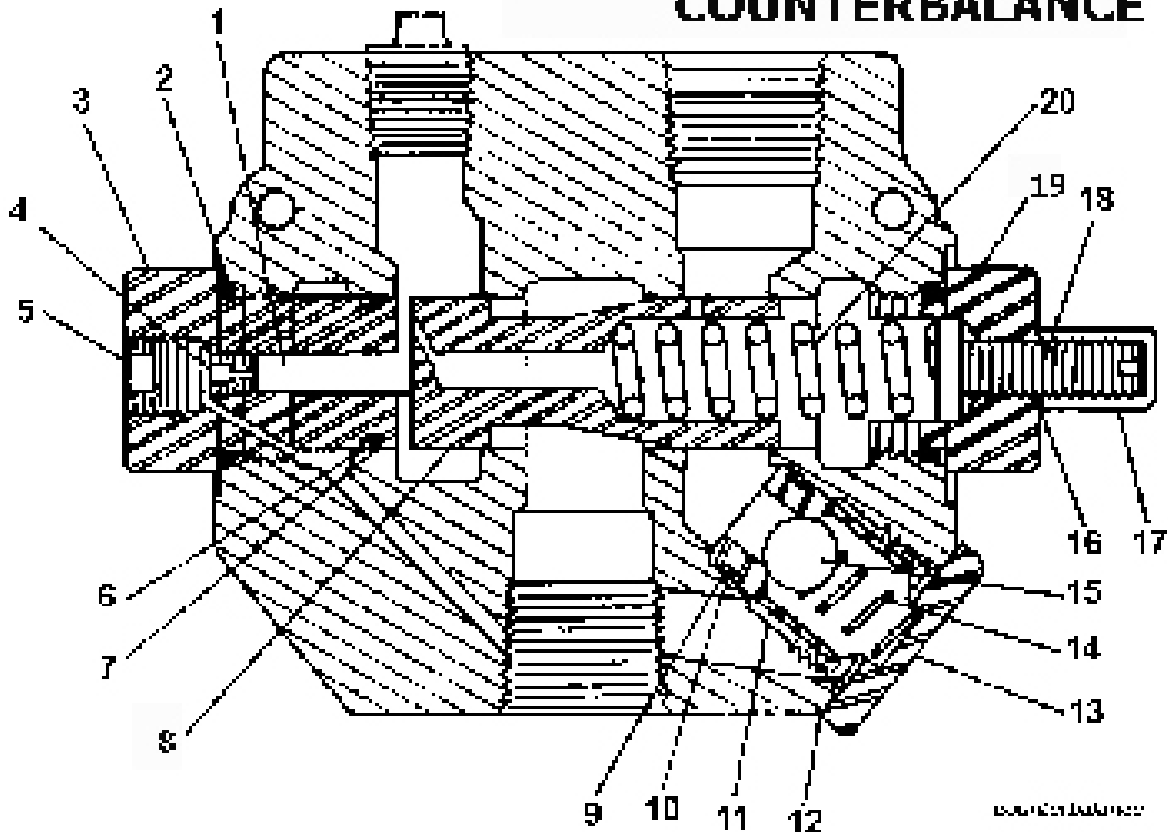

COUNTERBALANCE VALVE PART #A101H48

# SEQUENCE AND COUNTERBALANCE VALVE PARTS LIST

## SEQUENCE VALVE PART #A101H47 COUNTERBALANCE VALVE PART #A101H48

<u>KEY #</u>	<u>PART NO.</u>	<u>DESCRIPTION</u>
1	A101H49	Piston
2	A101H50	O-ring
3	A101H51	External pilot plug
4	A101H52	Orifice
5	A101H53	Plug
6	A101H54	O-ring
7	A101H55	Backup washer
*8	A101H56	Metering spool
9	A101H57	Backup washer
10	A101H58	O-ring
11	A101H59	Check seat
12	A101H60	Aluminum washer
13	A101H61	Check plug
14	A101H62	Check spring
15	A101H63	Check ball
16	A101H64	Aluminum washer
17	A101H65	Acorn nut
18	A101H66	Adjusting screw
19	A101H67	Adjusting plug - RD1075 CB
20	A101H68	Metering spring
21	A101H69	Adjusting Plug - RD1075 SM
22	A101H70	Metering Spool
*	A101H71	Valve body

\* NOT SOLD SEPARATELY

**IMPORTANT:** This Hyd. Manifold was intergrated into production April, 2006  
It replaces A125070 valve.  
For older machines see master parts book on Ashlandind.com.

## **HYDRAULIC MANIFOLD ASSEMBLY**

**A125174**

**S.N. 21403 & above**

### **SETTING THE APRON AND PUSHOFF VALVE**

The manifold block containing the pushoff sequence valve cartridge and apron sequence valve cartridge is used to control two hydraulic circuits with one hydraulic remote. when the tractor hydraulic remote is activated, oil flows first to the apron cylinders until they are fully extended. Once the cylinders are fully extended, the apron circuits' hydraulic pressure begins to increase. Once the pressure threshold is surpassed (which is adjustable. See adjustment section), the sequence valve diverts the oil flow to the pushoff's hydraulic circuit. Once the push off is completely extended the operator then reverses the tractors hydraulic remote. The counterbalance valve will hold the apron open until the push off is fully retracted. The Apron sequence valve then opens and allows the apron to close.

#### **Setting the valves:**

##### **STEP 1 PUSHOFF SEQUENCE VALVE**

Loosen the lock nut (9/16") on the sequence valve cartridge. Turn the setscrew (4mm) clockwise until the front apron rises before the push-off begins to advance. (Earthmover should be empty) Turn the adjustment screw an additional 1/4 turn clockwise and tighten jam nut.

##### **STEP 2 Counter Balance VALVE**

Loosen the lock nut (9/16") on the counterbalance valve cartridge. Turn the setscrew (4mm) counter-clockwise until the apron holds in a raised position while rear gate is being retracted. Turn adjustment screw an additional 1/4 turn, tighten jam nut. DO NOT tighten adjusting screw more than necessary.

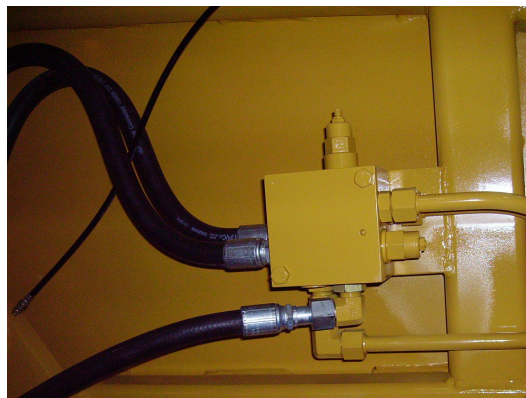

<b>ITEM #</b>	<b>PART NO.</b>	<b>DESCRIPTION</b>
1	A125162-01	CENTER BALANCE CARTRIDGE
2	A125162-02	SEQUENCE CARTRIDGE



# MAINTENANCE CHECKLIST

---

1. Grease all zerks.
  - a) Every 8 hours of operation.
  - b) See Lubrication Points section on following page.
2. Greasing the hubs.
  - a) Re-pack wheel bearings after 600 hrs of operation.
  - b) Completely clean grease out of hub and bearings every 1200 hours of operation.
3. Check tire pressure.
  - a) 20.5 - 25, 12-ply tire requires a tire pressure of 35-40 psi on a rear machine, 40-50 on a front machine..
4. Check all pins for signs of wear.
  - a) Daily
5. Check wheel lug nut torque.
  - a) After first 2 hours of operation.
  - b) Recheck daily for next 2 weeks.
  - c) Tighten wheel lug nuts in a star pattern.
  - d) Torque wheel lug nuts to 450 ft-lbs.
6. Check and retighten all bolts.
  - a) After initial 10 hours of use.
  - b) Again after 50 hours of use.
  - c) See Torque Specifications on following page.
7. Inspect cutting edges.
  - a) Daily
  - b) Replace cutting edges when center blade has been worn to approximately 6" and side edges worn to approximately 4".

---

**CAUTION!** Failure to replace worn cutting edges may result in unnecessary wear to the earthmover sides and floor.



---

Note: Please specify left or right "L" shaped cutting edges when ordering replacements.

# TORQUE SPECIFICATIONS

---

<i>Grade 8</i>	
<i>Bolt</i>	<i>Torque</i>
<i>Diameter</i>	<i>ft-lbs</i>
1/4"	12
5/16"	25
3/8"	45
7/16"	70
1/2"	110
9/16"	150
5/8"	220
3/4"	380
7/8"	600
1"	900
1-1/8"	1280
Lug Nuts	750

## LUBRICATION

---

1. Grease all zerks every 8 hrs of operation with high quality, general-purpose grease.
  - a) Grease until grease flows from around pin.

Lubrication Points (see Ill. on next page)

1. Hitch – Horizontal and vertical pins.
2. Lift Cylinders – Rod end & Trunion; Both left & right sides.
3. Front Arm Pivot Joint – Both left & right sides.
4. Apron Cylinders – Rod clevis pin; Both left & right sides.
5. Apron Pivot Pin – Both left & right sides.
6. Hold-down Rollers – Both left & right sides.
7. Floor Rollers – Both left & right sides.
8. Tapered Rollers – Both left & right sides.

# I-130TS Grease Locations

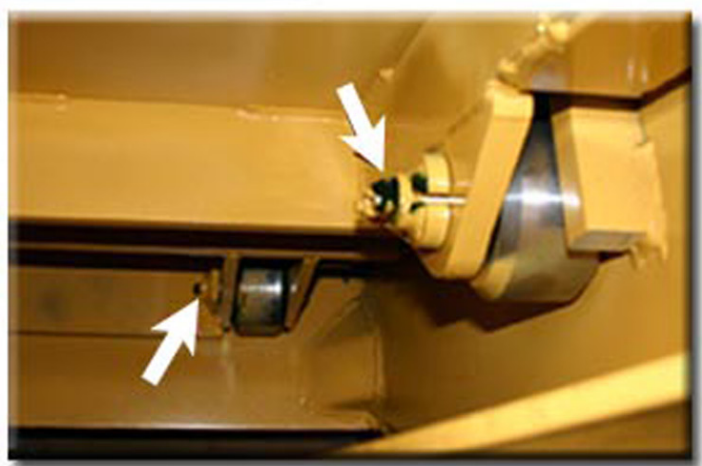
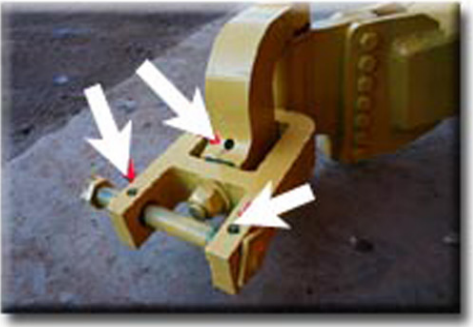
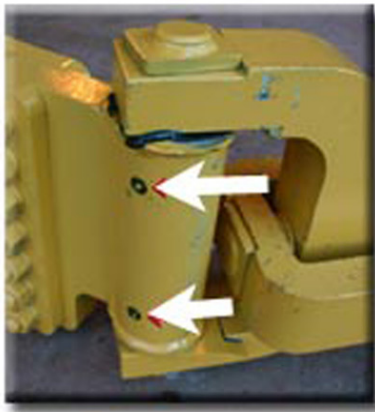
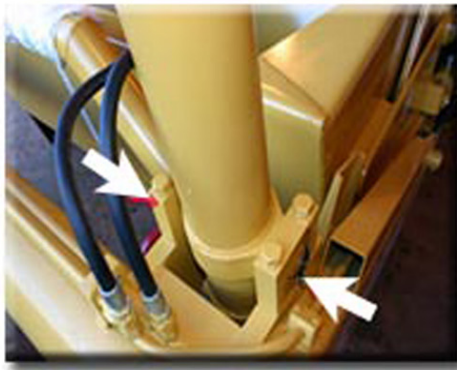

# HYDRAULIC SYSTEM

---

## **Standard Two-Circuit Hydraulic Plumbing**

The apron cylinders and the push-off cylinder are controlled on the same circuit with the sequence of the operation controlled by a sequence valve. The other hydraulic circuit controls the lift cylinders on the earthmover.

**\*To adjust the sequence valve, see Troubleshooting section.**

## **Optional Three-Circuit Hydraulic Plumbing**

The apron cylinders, push-off cylinder, and lift cylinders are all on separate hydraulic circuits.



**CAUTION!** Relieve all hydraulic pressure before working on the hydraulic system.

---

**WARNING! High Pressure Fluid Hazard – To prevent serious injury or death from high pressure fluid:**

- a) **Relieve pressure on hydraulic system before repairing, adjusting, or disconnecting.**
  - b) **Wear proper hand and eye protection when searching for leaks.**
  - c) **Keep all components in good repair.**
-

## PUSHING THE EARTHMOVER

---

The I-130TS was designed to be pushed when equipped with the optional push-bar. However, Ashland Industries, Inc. **STRONGLY** recommends using extreme caution when pushing the I-130TS earthmover to prevent any unnecessary damage.



---

**CAUTION!** The I-130TS earthmover must be pushed in a straight line with a maximum of a 100 hp dozer. Do not ram or jar the earthmover while pushing and push at a constant speed.

---



# TROUBLESHOOTING

---

## Introduction

---

With proper care and maintenance, the I-130TS will give many years of reliable service. When a situation arises where the earthmover performance is not satisfactory, this section will give some pointers on finding and correcting the problem.

---

### Grease zerk will not take grease.

---

1. Grease zerk plugged.
  - a) Remove and replace grease zerk.
2. Pin is frozen.
  - a) Remove, clean, and inspect pin.
  - b) Replace pin if necessary.
3. Bushing grease passage is not aligned with grease zerk.
  - a) Remove, clean, inspect, and realign bushing.
  - b) Replace bushing if necessary and realign.

---

### Push-off rollers do not roll.

---

1. The rollers need lubrication.
  - a) Check zerk hole and grease.
  - b) Remove pin, clean, inspect, and replace if necessary.
2. The roller bushing is worn out.
  - a) Remove roller assembly and replace bushing.
  - b) See parts manual.

---

### Cylinders will not hold in preset position, i.e. the cylinder creeps.

---

1. Seals leaking internally.
  - a) Remove and replace seal kit.



---

## Machine cuts unevenly.

---

1. Cutting edges worn unevenly.
  - a) Replace cutting edges.
2. Improperly inflated tires.
  - a) Check air pressure in tires.

---

## Apron closes slowly

or

## Apron and push-off are not working well together.

---

1. Sequence valve needs adjusting.
  - a) Remove acorn nut from end of sequence valve with a 1/2" wrench. Turn adjustment screw, using a 4mm hex wrench, clockwise until front apron rises before the push-off advances while the earthmover is empty. Turn the adjustment screw an additional 1/4 turn clockwise, then replace the acorn nut and tighten.
  - b) Torque check valve assembly and int. pilot plug to **25 ft-lbs maximum**.



**CAUTION!** Overtightening check valve assembly and int. pilot plug will cause internal damage to the sequence valve.

---

\* **Note: Check valve assembly may leak slightly when torqued to 25 ft-lbs.**

---

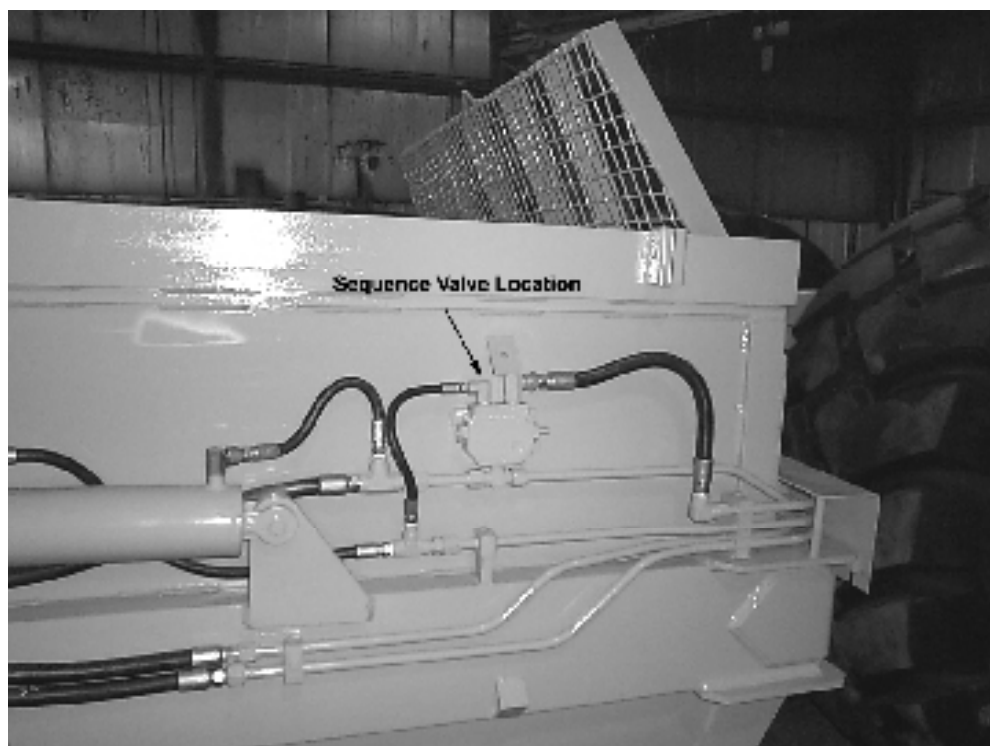



# Limited Warranty Statement

Ashland Industries Inc. warrants each new product to be free from defects in material and workmanship. This warranty is applicable only for the normal service life expectancy of the product or components, not to exceed **six consecutive months** from the date of delivery of the new Ashland Industries product to the original purchaser, or the date the product is first put into service via a rental agreement or other means, whichever occurs first.

Genuine Ashland Industries Inc. replacement parts and components will be warranted for 30 days from date of purchase, or the remainder of the original equipment warranty period, whichever is longer.

Under no circumstances will it cover any merchandise or components thereof, which in the opinion of the company, has been subjected to misuse, unauthorized modification, alterations, an accident or if repairs have been made with parts other than those obtained through Ashland Industries Inc.

Ashland Industries Inc. in no way warrants Tires since these items are warranted separately by their respective manufacturer. Please call Ashland Industries Inc. to receive phone numbers of tire suppliers.

Ashland Industries Inc. in no way warrants wearable items such as cutting edges, front dolly wheel balls, socket halves.

Our obligation under this warranty shall be limited to repairing or replacing, free of charge to the original purchaser, any part that, in our judgement, shall show evidence of such defect, provided further that such part shall be returned within 30 days from the date of failure to Ashland Industries Inc. routed through the dealer and distributor from whom the purchase was made, transportation charges prepaid. Upon warranty approval proper credits will be reimbursed for transportation.

This warranty shall not be interpreted to render Ashland Industries Inc. liable for injury or damages of any kind or nature to person or property. This warranty does not extend to the loss revenue, extra labor cost associated with downtime, substitute machinery, rental or for any other reason.

Except as set forth above, Ashland Industries Inc. shall have no obligation or liability of any kind on account of any of its equipment and shall not be liable for special or consequential damages. Ashland Industries Inc. make no other warranty, expressed or implied, and, specifically, Ashland Industries Inc. disclaims any implied warrant or merchantability or fitness for a particular purpose. Some states or provinces do not permit limitations or exclusions of implied warranties or incidental or consequential damages, so the limitations or exclusion in this warranty may not apply.

This warranty is subject to any existing conditions of supply which may direct affect our ability to obtain materials or manufacture replacement parts.

Ashland Industries Inc. reserves the right to make improvements in design or changes in specifications at any time, without incurring any obligation to owners of units previously sold

No one is authorized to alter, Modify or enlarge this warranty nor the exclusion, limitations and reservations.

Ashland Industries Inc.  
Warranty Department