



I-110-TS PARTS MANUAL

Ashland Industries Inc.
Hwy. 13 South
P.O. Box 717
Ashland, WI. 54806
877-634-4622 Toll Free - phone
715-682-4622 phone
715-682-9717 fax
www.ashlandind.com





HOW TO ORDER PARTS:

IMPORTANT

Parts must be ordered through your local authorized Ashland Industries dealer.

Be sure to state Model and Serial Number of your machine, part number, description and quantity needed.

Unless this is done, we cannot provide prompt service or assure shipment of correct parts.

INDEX

Page 3.	Operators and Maintenance Instructions
Page 4.	Illustration and Parts List - Swivel Hitch
Page 5.	Illustration and Parts List - Front End Assembly
Page 6.	Illustration and Parts List - Apron Assembly
Page 7.	Illustration and Parts List - Bowl and Frame
Page 8.	Illustration and Parts List - Push Off Gate Assembly
Page 9.	Illustration and Parts List - Rear Wheel and Hub Assembly
Page 10.	Illustration and Parts List - Apron Cylinder 4" X 13"
Page 11.	Illustration and Parts List - Lift Cylinder 5" x 16"
Page 12.	Illustration and Parts List - Push Off Cylinder 4" x 54"
Page 13.	Illustration and Parts List - Push Off Cylinder 4-1/2" x 54" Op tional
Page 14.	Illustration - Push Off Cylinder 5" x 54" Optional
Page 15.	Illustration and Parts List - Push Off Cylinder 5" x 54" Optional
Page 16-17	Illustration, Parts List and Adjustment - Sequence Valve
Page 18-22	Service Manual Appendix
Page 23-24	Troubleshooting
Page 25.	Warranty Statement

OPERATORS AND MAINTENANCE INSTRUCTIONS

The scraper is a durable piece of equipment and with proper care will yield many years of trouble free operation. The scraper requires a power source with TWO 4 way (double acting) hydraulic control valves.

The scraper should be greased at all points where grease fittings are provided. Connect hydraulic hoses to the tractor and retract lift cylinders to remove transport lock pins, then extend and retract all cylinders several times to force out any air from the hydraulic cylinders and lines. Check the oil levels in the tractor hydraulic system and add to maintain the proper level. Care should be used when adding oil or when disconnecting any oil line to keep all dirt out of the oil as dirt is a major factor in the failure of hydraulic components.

When the scraper is placed into operation, the operator will have to "feel out" the amount of depth of cut to obtain maximum loading efficiency. This is usually accomplished by taking a lesser and more uniform cut. However, some soil conditions such as loose sand may require a "pumping action" obtained by taking successive deep cuts and lifting out of cut as the tractor begins to lose power or traction.

1. After 10 hours work, all bolts should be checked and tightened if necessary.
2. Every 10 hours all grease fittings should be lubricated.
3. After 50 hours work, all bolts should be rechecked and tightened if necessary. Check wheel bearings and adjust if necessary.
4. After 300 hours work, clean and repack wheel bearings and replace, if necessary, cutting edges, worn pins, etc..
5. Tighten all wheel bolts after first two hours use. Check daily for two weeks. Keep torqued to 450 ft. lbs..
6. Maintain tire pressure at 35 to 40 psi on a rear unit, 40-50 on a front unit.



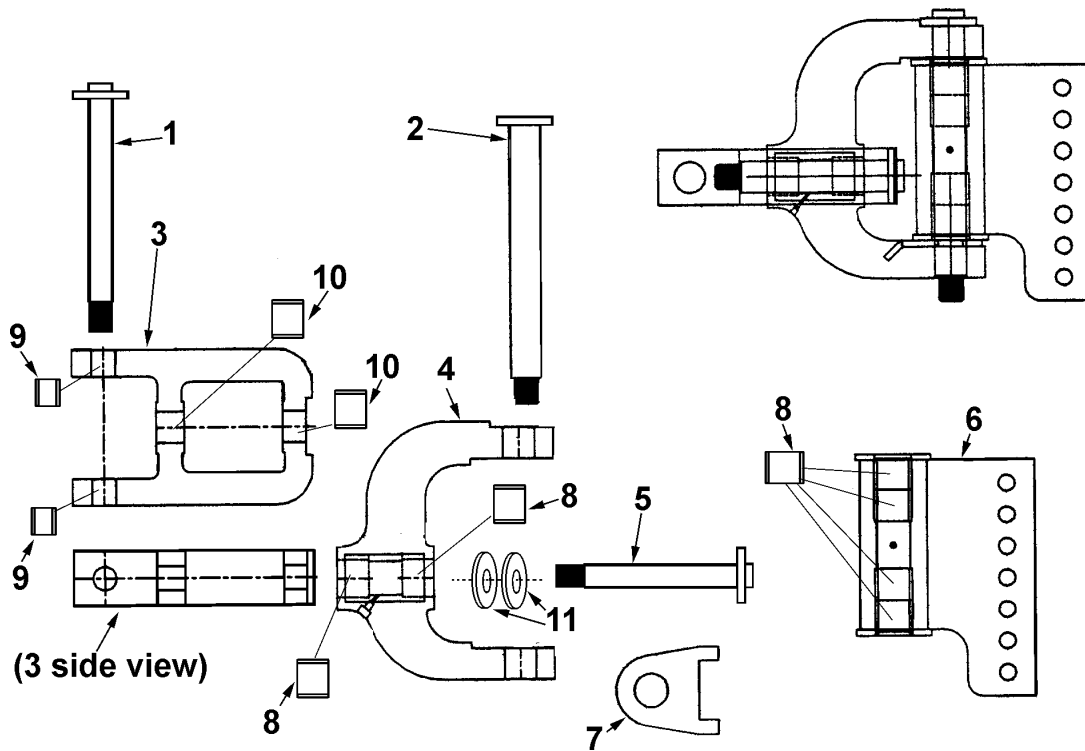

KEY NO.	PART NO.	DESCRIPTION
1.	A123299-08	Pin: Four Ear Drawbar To Hitch
	A123299-07	Pin: Two Ear Drawbar To Hitch
	AFN-00014	Nut: 1-1/2" NC Slotted
2.	A123299-06	Pin: Sq. Tab Head 2 X 18-1/2"
	AFN-00018	Nut: 1-1/2" NF Top Lock
3.	A123299-03R	A-Frame Hitch
4.	A123299-02	C-Frame Hitch: Offset
5.	A123299-05	Pin: Sq. Tab Head 1-1/2 X 12-1/2"
	AFN-00018	Nut: 1-1/2" NF Top Lock
6.	A123299-01	Vertical Mounting Tube: 7 Hole
7.	A123299-04	Wear Pad With Locking Legs
8.	ABS-00001	Bushing: 2-3/8" OD x 2" ID
9.	A123299-09	Bushing: 2" OD x 1-1/2" ID x 1-1/2" (2 req'd)
10.	A123299-10	Bushing: 2-3/8" OD x 2" ID x 1-1/2" (2 req'd)
11.	A123299-11	Hardened Washer, 2" (2 req'd)

FRONT END

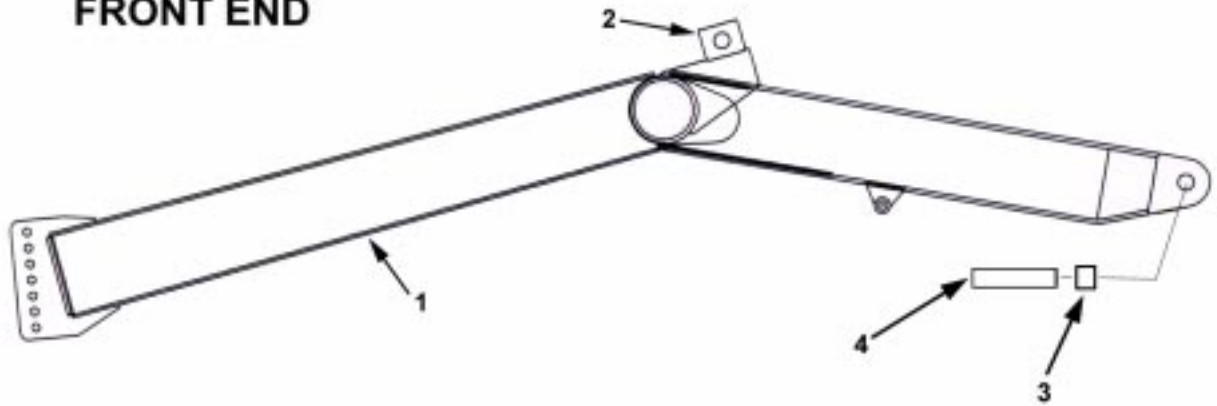

KEY NO.	PART NO.	DESCRIPTION
1.	A123292	Front End Assembly
2.	A123293A	Trunion Mount Block
3.	A14039	Bushing, 2-3/8" OD x 2" ID x 2" Long with Grease Passage
4.	A10152A	Frame Attachment Pin, 2" x 8-1/16"

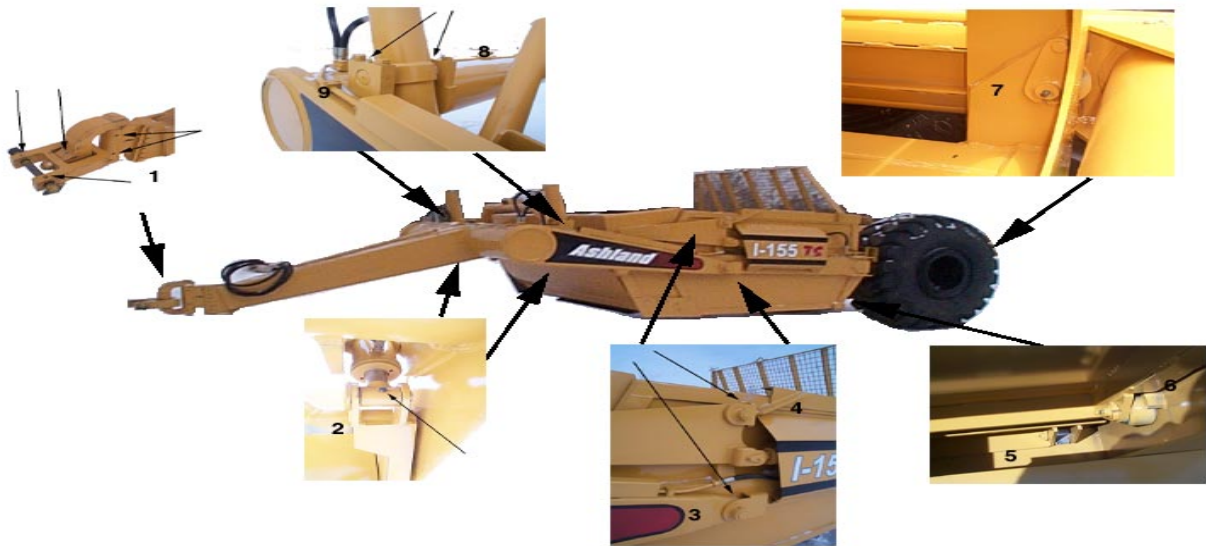

KEY NO.	PART NO.	DESCRIPTION
1	A123340	Apron
2	A123343	Bushing, 2" OD x 1-1/2" ID x 1-3/4" long,
3	A123336	Pin
4	7450	Nut: 3/8" NC
5	AFB-00049	Bolt: 3/8 NC X 3"

BOWL AND FRAME ASSEMBLY

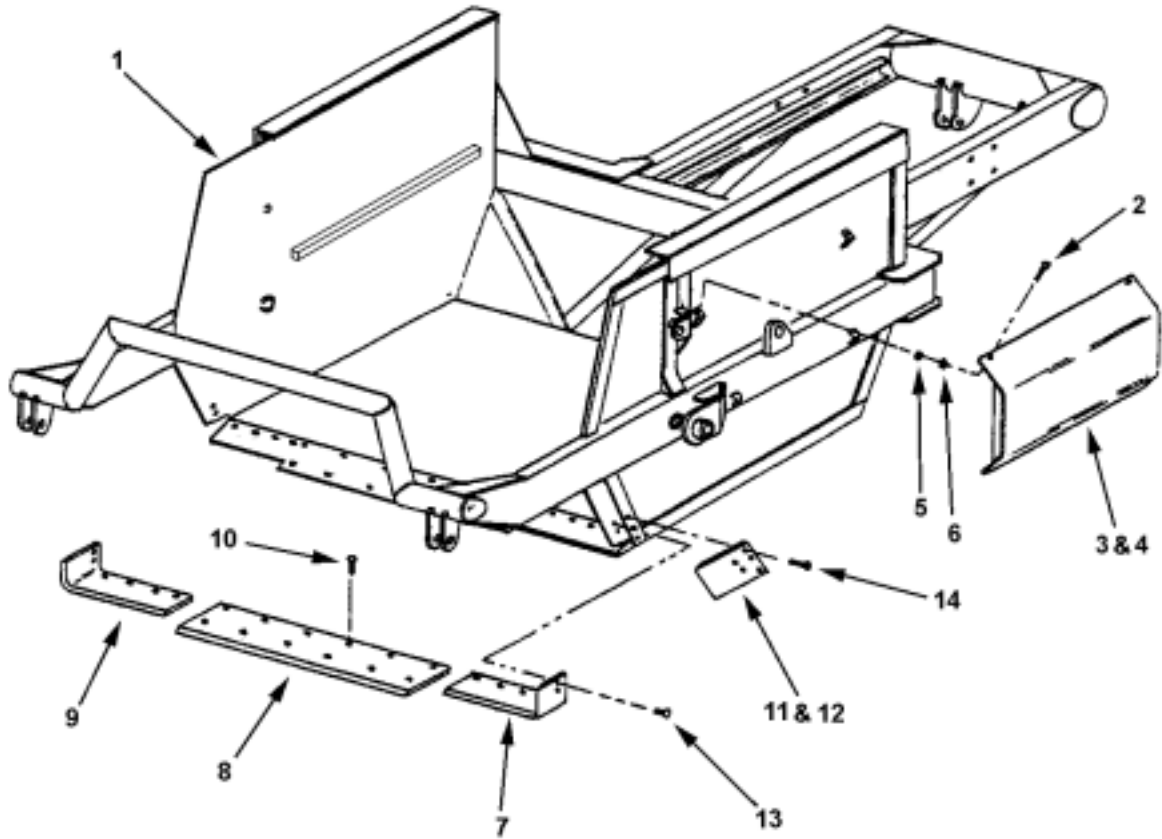

115-138 bowl

KEY NO.	PART NO.	DESCRIPTION
1	A123302B	Bowl and Frame I-110TS
2	6835	Bolt, 3/8" NC x 1"
3	A10157	Left hand cylinder guard
4	A10158	Right hand cylinder guard
5	8078	3/8" Lockwasher
6	7450	Nut, 3/8" NC
7	A123332L	Left cutting edge, 8"
8	A1233331	Center cutting edge, 12" x 54"
9	A123332R	Right cutting edge, 8"
10	PB9P-NC-088-0275	Plow bolt, 7/8" NC x 2-3/4" (12 req'd.)
	AFN-00019	Nut: 7/8" NC (12 req'd./ center blade)
11	A123338L	Left Bank Shaver Side Blade
12	A123338R	Right Bank Shaver Side Blade
13	PB9P-NC-088-0275	Plow bolt, 7/8" NC x 2-3/4" (6 req'd./ corner blade)
	AFN-00019	Nut: 7/8" NC (6 req'd./ corner blade)
14	PB9P-NC-088-0275	Plow bolt, 7/8" NC x 2-3/4" (4 req'd./ shaver blade)
	AFN-00019	Nut: 7/8" NC (4 req'd./ shaver blade)
	PB9P-NC-088-0225	Plow bolt, 7/8" NC x 2-1/4" (3 req'd./ shaver blade)
	AFN-00026	Nut: 7/8" NC Jam (3 req'd./ shaver blade)

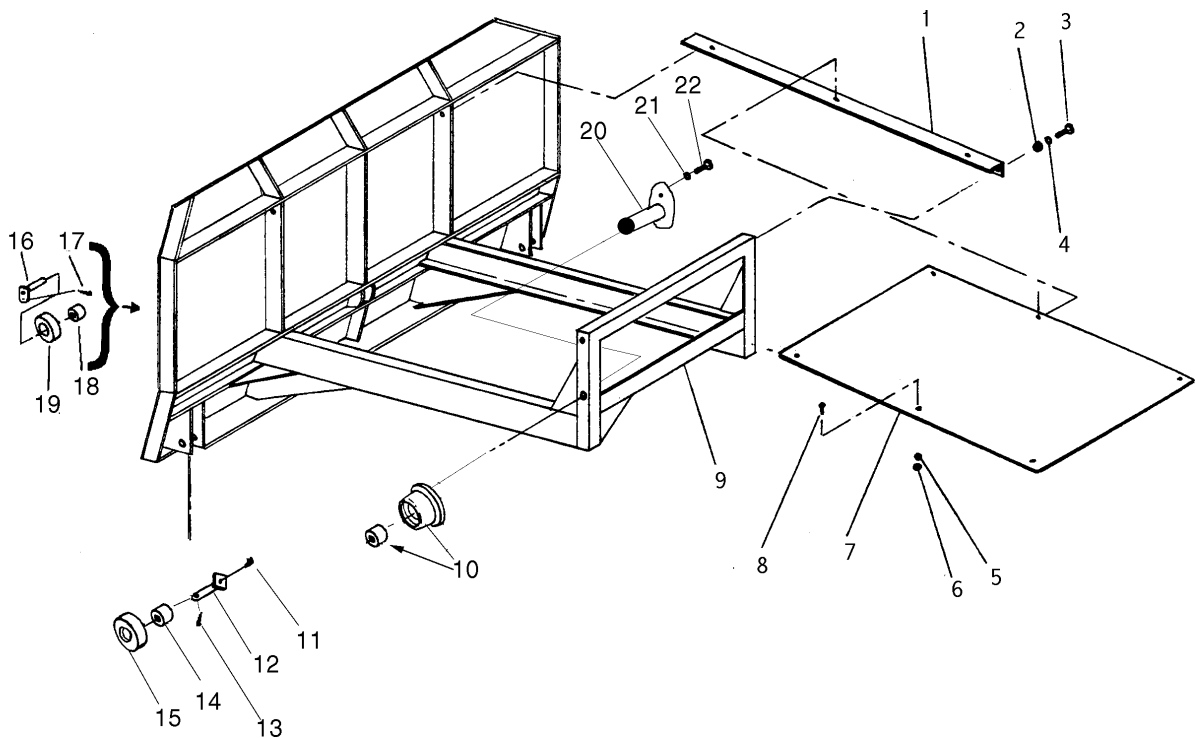

KEY NO.	PART NO.	DESCRIPTION
1.	A10159	Brace (L.H. & R. H. same)
2.	AFN-00006	Nut: 3/4" NC
3.	AFB-00037	Bolt: 3/4" NC x 2" Lg.
4.	AFW-00002	Lockwasher: 3/4"
5.	8078	Lockwasher: 3/8"
6.	7450	Nut: 3/8" NC
7.	A10171	Dirt Shield
8.	AFB-00034	Bolt: 3/8 NC x 1" Lg.
9.	A10160	Pushoff Gate: Model I-110
10.	A123306	Roller: Rear Gate
	A123307	Bushing" 1-5/8" OD x 1-1/4" ID
11.	AHF-00028	Grease Fitting: 1/8" NPT -90 degree
12.	A6007A	Pin: 1-1/4" x 4-1/8" Lg.
13.	AFP-00001	Cotter Pin: 1/4 X 3-1/2"
14.	A10163	Bushing: 1-3/4" OD x 1-1/4" ID
15.	A10164	Roller: 4-1/4 OD X 1-3/4 ID
16.	A123288	Pin: 1-1/4 X 3-1/4" Tab Head
17.	7036	Bolt: 1/2 NC X 2"
18.	A10163	Bushing: 1-3/4" OD x 1-1/4" ID
19.	A10164	Roller: 4-1/4 OD X 1-3/4 ID
20.	A123305	Pin: 1-1/4 X 2-3/4"
21.	8100	Lockwasher: 1/2"
22.	AFB-00033	Bolt: 1/2 NC X 2-1/2"

REAR WHEEL, SPINDLE & HUB ASSEMBLY

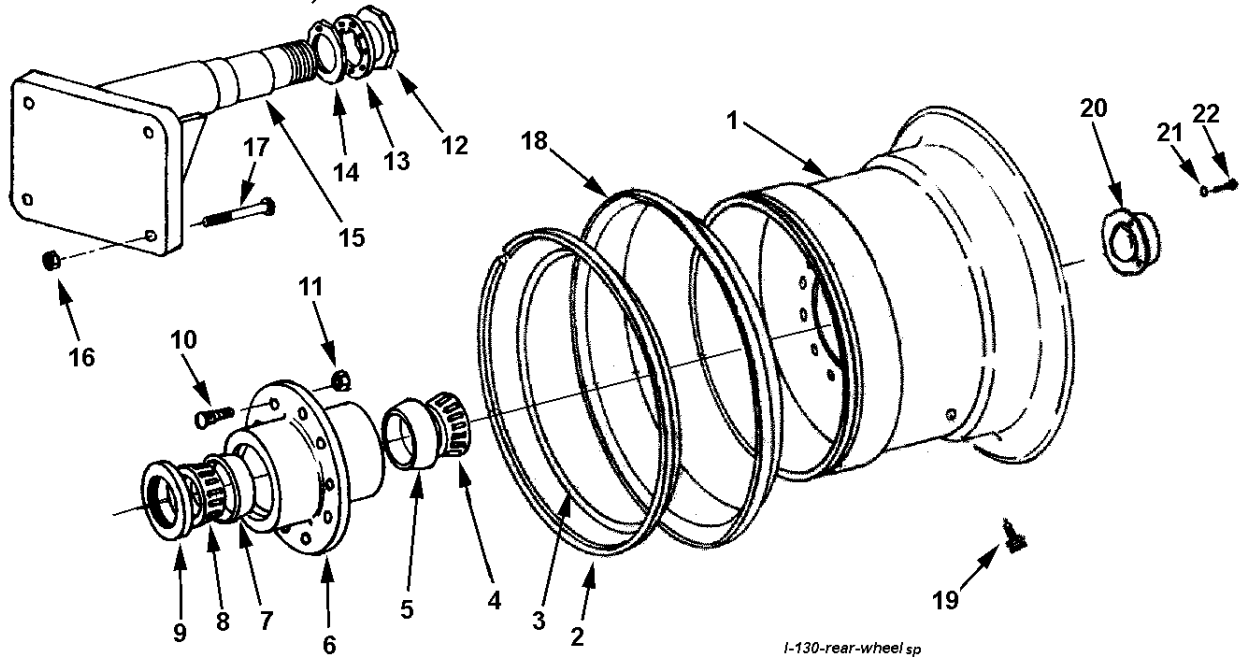

KEY NO.	PART NO.	DESCRIPTION
1	A14035	Wheel - 17" x 25"
2	A14008	O-Ring
3	A14038	Lock Ring
4	A14015	Bearing cone (Timken 644)
5	A14014	Bearing cup (Timken 632)
6	A14010	Hub
7	A14013	Bearing cup (Timken 742)
8	A14012	Bearing cone (Timken 749)
9	A14011	Grease seal (CR 42624)
10	A10176	Stud
11	A10046	Lug nut
12	A10048	Spindle nut
13	A10049A	Lock collar
14	A10172	Nut w/ lock pin
15	A14037	Spindle
16	AFN-00001	Nut, 1" NF Toplock
17	AFB-00017	Bolt, 1" NF x 6-1/2" lg.
18	A14036	Slide Ring
19	A14016	Valve Stem
20	A14004	Hub Cap
21	8070	Lockwasher, 5/16"
22	AFB-00026	Bolt, 5/16" NC x 5/8" lg.

**LEFT & RIGHT
APRON CYLINDER
A123319**

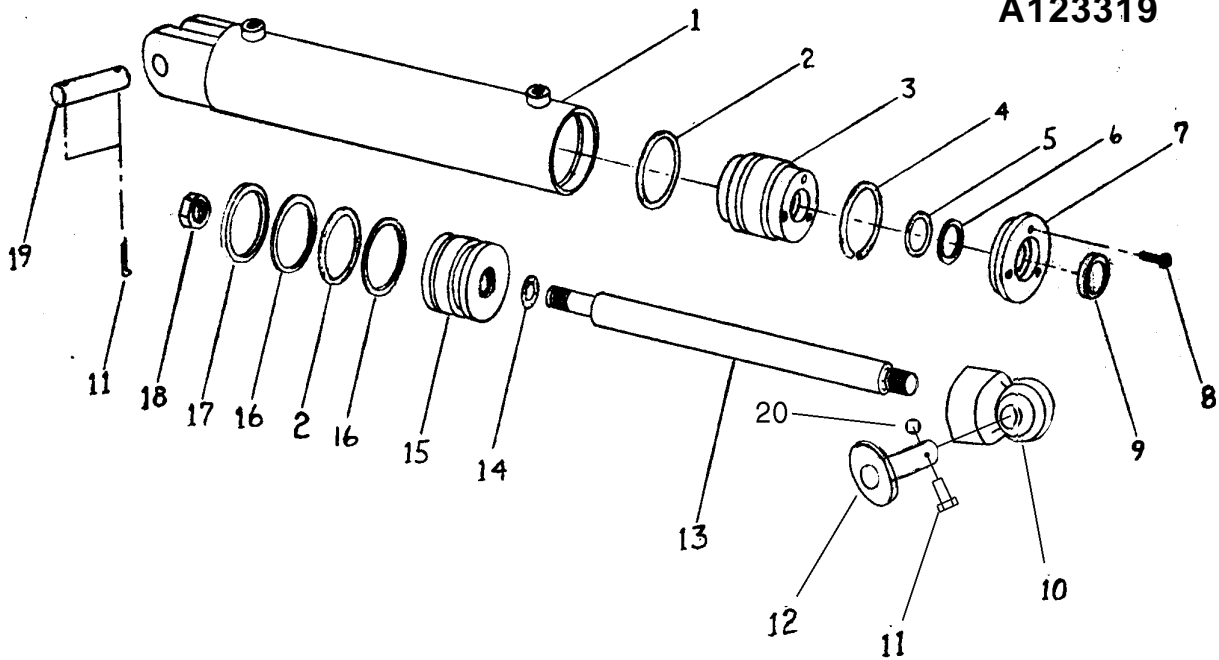

KEY NO.	PART NO.	DESCRIPTION
1	A175H01	Barrel Assembly
2	A300H06	O-ring seal, 4" OD x 3/16"
3	A300H11	Head gland
4	A300H12	Retainer ring
5	A22H15	O-ring, 1-1/2" x 1/8"
6	A22H15A	Backup washer
7	A300H13	Head cap
8	A22H18	Capscrew, 1/4 NC x 1"
9	A22H17	Wiper seal, 1-1/2" ID
10		Ball Swivel End
11	AFB-00015	HHCS: 1/2 NC x 1-1/2"
12	A123336	Pin: Tab Head w/Grease Fitting
13	A175H02	Shaft, 1-1/2" diameter
14	A45H05	Piston gasket, 1"
15	A300H07	Piston, 4" dia.
16	A300H05	Back up washer, 4" OD
17	A300H04	Cast iron ring, 4" OD
18	A300H03	Piston nut, 1" NF
19	A1217	Pin, 1" x 3-1/2"
20.	7500	Nut: 1/2" NC
	A300H14B	Packing kit containing:
		1 - A300H04 2 - A22H15 2 - A300H05
		1 - A22H15A 2 - A22H06 1 - A22H17
		1 - A45H05

LIFT CYLINDER
5" x 16" TRUNION MOUNT
PART NO. A123324

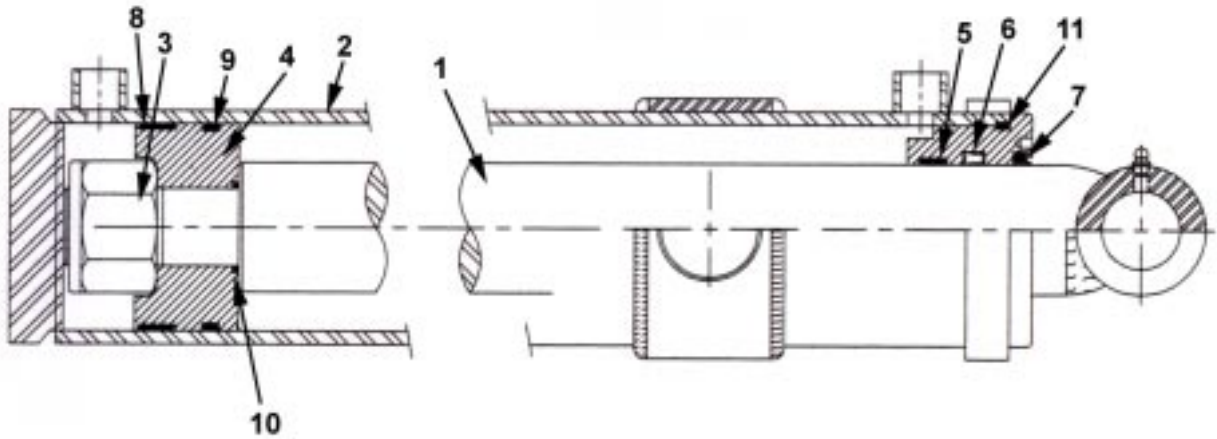

KEY NO.	PART NO.	DESCRIPTION
1	A123324-1	2-1/2" Rod
2	A123324-2	Barrel Weldment
3	A123324-3	Lock Nut 1-1/2"-12
4	A123324-4	Piston
5	A123324-5	Gland
6	A123324-6	Rod Seal
7	A123324-7	Rod Wiper
8	A123324-8	Wear Ring
9	A123324-9	Piston Seal (2-pc.)
10	A123324-10	O-ring
11	A123324-11	O-ring
	AHS-00140	Seal Kit (Items 6-11)

I-110 PUSH GATE CYLINDER ASSEMBLY PART NO. A454H114B
4" BORE X 54" STROKE

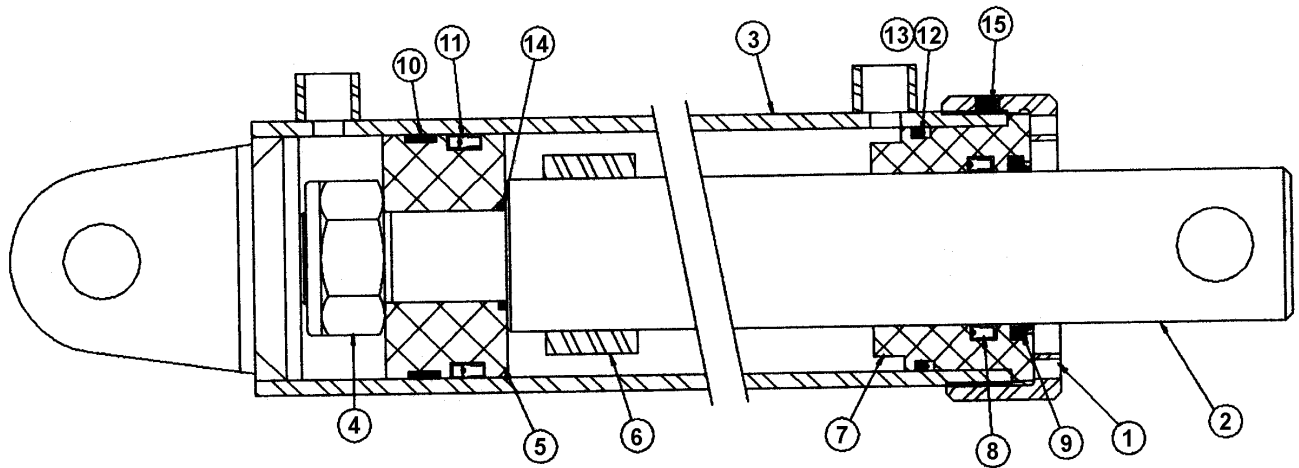

I-110-cyl-push

KEY NO.	QTY.	PART NO.	DESCRIPTION
1	1	A101H103	Collar
2	1	A101H98	2 1/2" Rod
3	1	A101H97	Barrel weldment
4	1		Lock nut (1 1/2" - 12)
5	1	A101H96	Piston
6	1	A101H99	Spacer
7	1	A101H102	Head
8	1	A140H07	Rod seal
9	1	A140H08	Rod wiper
10	1	A101H100	Wear ring
11	1	A101H101	Piston seal
12	1	A200H06	O-ring
13	1	A300H05	Backup ring
14	1	A22H15	O-ring
15	1		Nylon tip set screw (3/8" NC x 3/8)
16	1	A101H30A	Seal kit (Items 8-14)

I-1 0 PUSH GATE CYLINDER ASSEMBLY PART NO. A455H114

4 1/2" BORE X 54" STROKE

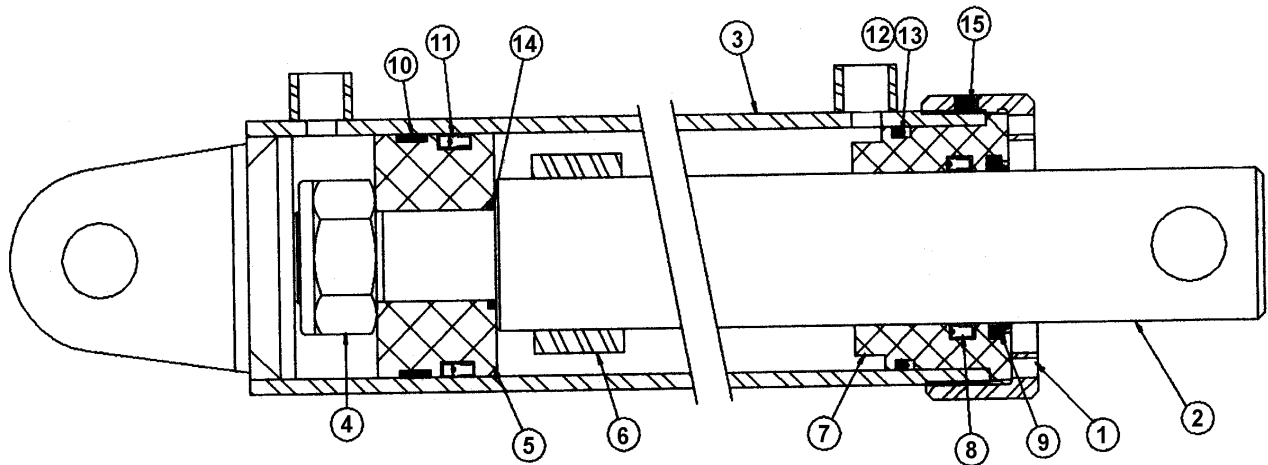

I-130-cyl-push

KEY NO.	QTY.	PART NO.	DESCRIPTION
1	1	A175H10	Collar
2	1	A130H30	2 1/2" Rod
3	1	A130H29	Barrel weldment
4	1	A140H13	Lock nut (2" - 12)
5	1	A175H12	Piston
6	1	A17506	Spacer
7	1	A175H09	Head
8	1	A140H07	Rod seal
9	1	A140H08	Rod wiper
10	1	A175H07	Wear ring
11	1	A175H05	Piston seal
12	1	A175H03	O-ring
13	1	A175H04	Backup ring
14	1	A140H14	O-ring
15	1		Nylon tip set screw (3/8" NC x 3/8)
16	1	A175H15	Seal kit (Items 8-14)

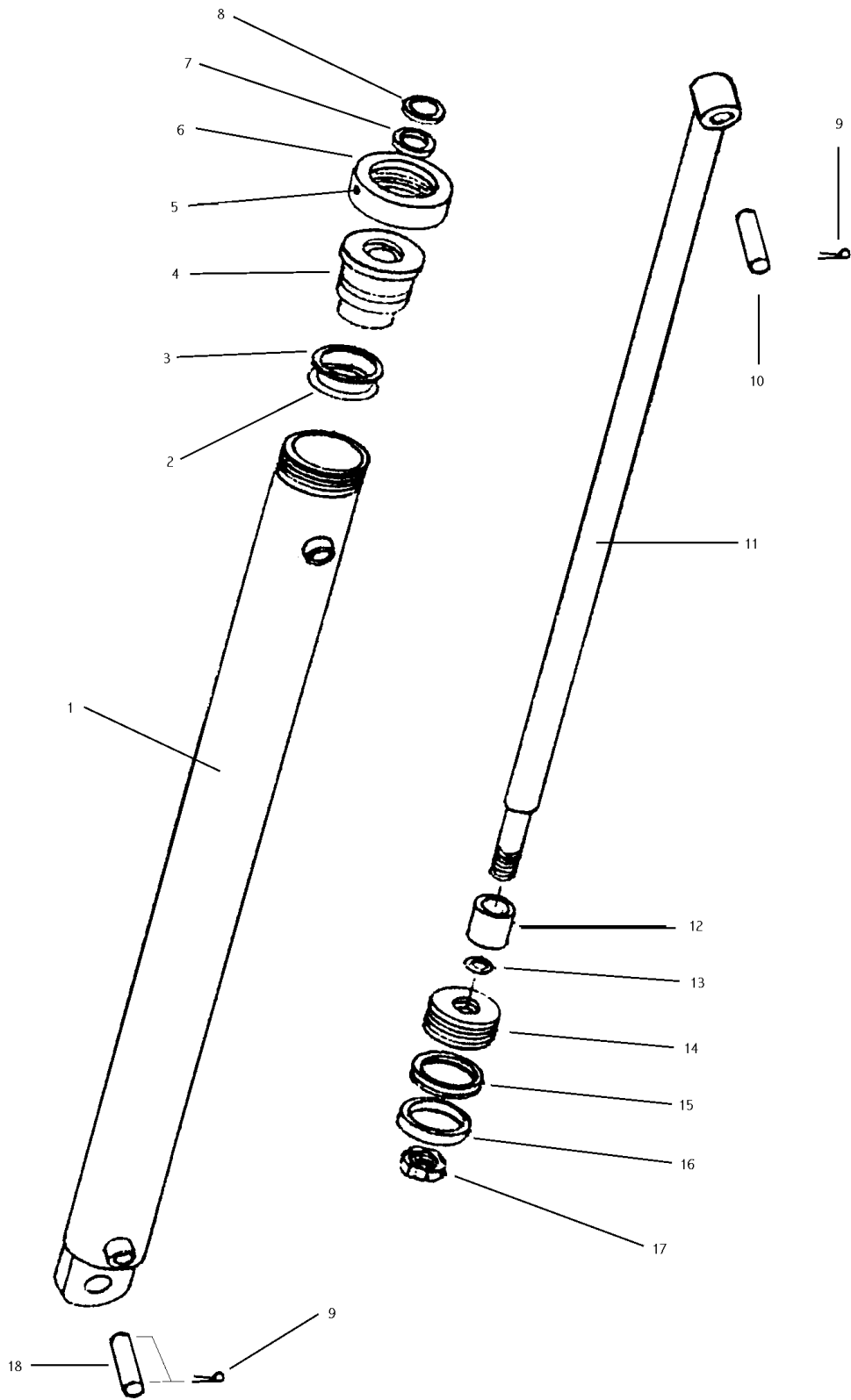

KEY NO.	PART NO.	DESCRIPTION
1.	A123324	Barrel Assembly: 5" Bore
2.	A400H06	O-Ring: 5" OD X 4-1/2" ID
3.	A400H05	Back Up Washer: 5" OD X 4-1/2" ID
4.	A140H21	Head Gland: 5"
5.	-----	Set Screw: 3/8" NC
6.	A140H19	Collar
7.	A140H07	Shaft Seal: 2-1/2" ID X 3" OD OU-Cup
8.	A140H08	Wiper Seal: 2-1/2" ID X 2-15/16" OD
9.	8602	Cotter Pin: 1/4" X 2"
10.	A14033	Pin: 1-1/4" Dia. X 5" Lg.
11.	A130H30	Shaft: 2-1/2" Dia.
12.	A175H06	Spacer
13.	A22H15	O-Ring: 1-1/2" x 1-3/4" OD
14.	A140H22	Piston: 5"
15.	A140H24	Piston Seal: 5" OD X 4-1/4" ID
16.	A140H25	Wear Ring: 5" OD
17.	AFN-00018	Lock Nut: 1-1/2" NF
	A140H28	Packing Kit: Containing:
		(1) A140H25 (1) A400H06
		(1) A140H07 (1) A140H08
		(1) A22H15 (1) A400H05
		(1) A140H24
18.	A9024	Pin: 1-1/4 X 4-3/4"

SEQUENCE VALVE

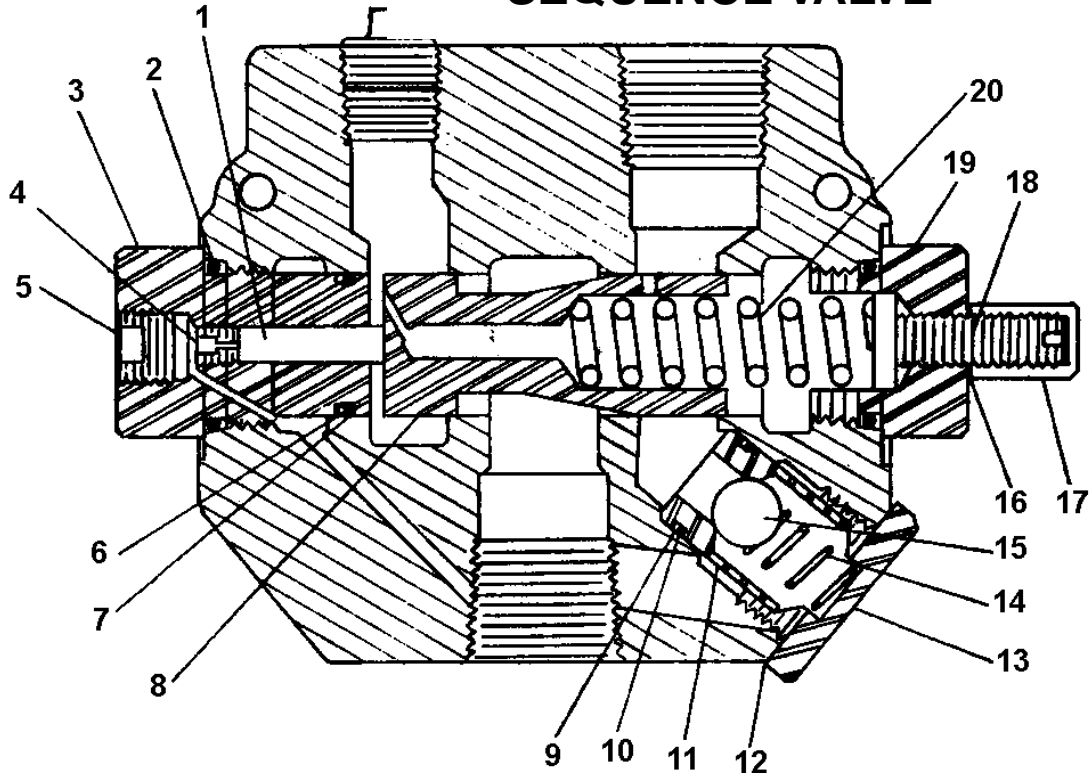

KEY NO.	PART NO.	DESCRIPTION
1	A101H49	Piston
2	A101H50	O-ring
3	A101H51	External pilot plug
4	A101H52	Orifice
5	A101H53	Plug
6	A101H54	O-ring
7	A101H55	Backup washer
*8	A101H70	Metering spool
9	A101H57	Backup washer
10	A101H58	O-ring
11	A101H59	Check seat
12	A101H60	Aluminum washer
13	A101H61	Check plug
14	A101H62	Check spring
15	A101H63	Check ball
16	A101H64	Aluminum washer
17	A101H65	Acorn nut
18	A101H66	Adjusting screw
19	A101H69	Adjusting plug - RD1075 SM
20	A101H68	Metering spring
*	A101H71	Valve body

* NOT SOLD SEPARATELY

SEQUENCE VALVE

The sequence valve controls two hydraulic circuits with one hydraulic remote. Ashland Industries incorporates a sequence valve to control the Apron and Pushoff cylinder systems. When the tractors hydraulic remote is activated, oil flows first to the apron cylinders until they are fully extended. Once the cylinders are fully extended, the apron circuits' hydraulic pressure begins to increase. Once the pressure threshold is surpassed (which is adjustable. See adjustment section), the sequence valve diverts the oil flow to the pushoff's hydraulic circuit. Once the pushoff is completely extended the operator then reverses the tractors hydraulic remote. This will direct oil first to the Apron circuit. Once the aprons cylinders are fully retracted, again the hydraulic pressure begin to increase allowing the pushoff to retract fully once the oil has been diverted from the sequence valve.

INSTRUCTIONS for establishing sequence valve setting:

Remove acorn nut from end of sequence valve with a 1/2" wrench. Turn adjustment screw, using a 4mm hex wrench, clockwise until front apron rises before the push-off advances while the earthmover is empty. Turn the adjustment screw an additional 1/4 turn clockwise, then replace the acorn nut and tighten. Torque check valve assembly and internal pilot plug to 25 ft.-lbs. maximum.

MAINTENANCE CHECKLIST

1. Grease all zerks.
 - a) Every 8 hours of operation.
 - b) See Lubrication Points section on page 3.

2. Greasing the hubs.
 - a) Re-pack wheel bearings after 600 hrs of operation.
 - b) Completely clean grease out of hub and bearings every 1200 hours of operation.

3. Check tire pressure.
 - a) 20.5 - 25, 12-ply tire requires a tire pressure of 35-40 psi on a rear machine, 40-50 on a front machine..

4. Check all pins for signs of wear.
 - a) Daily

5. Check wheel lug nut torque.
 - a) After first 2 hours of operation.
 - b) Recheck daily for next 2 weeks.
 - c) Tighten wheel lug nuts in a star pattern.
 - d) Torque wheel lug nuts to 450 ft-lbs.

6. Check and retighten all bolts.
 - a) After initial 10 hours of use.
 - b) Again after 50 hours of use.
 - c) See Torque Specifications on page 3.

7. Inspect cutting edges.
 - a) Daily
 - b) Replace cutting edges when center blade has been worn to approximately 6" and side edges worn to approximately 4".



CAUTION! Failure to replace worn cutting edges may result in unnecessary wear to the earthmover sides and floor.

Note: Please specify left or right "L" shaped cutting edges when ordering replacements.

TORQUE SPECIFICATIONS

<i>Grade 8</i>	
<i>Bolt</i>	<i>Torque</i>
<i>Diameter</i>	<i>ft-lbs</i>
1/4"	12
5/16"	25
3/8"	45
7/16"	70
1/2"	110
9/16"	150
5/8"	220
3/4"	380
7/8"	600
1"	900
1-1/8"	1280
Lug Nuts	750

LUBRICATION

1. Grease all zerks every 8 hrs of operation with high quality, general-purpose grease.
 - a) Grease until grease flows from around pin.

Lubrication Points (*see Ill. on next page*)

1. Hitch – Horizontal and vertical pins.
2. Lift Cylinders – Rod end & Trunion; Both left & right sides.
3. Front Arm Pivot Joint – Both left & right sides.
4. Apron Cylinders – Rod clevis pin; Both left & right sides.
5. Apron Pivot Pin – Both left & right sides.
6. Hold-down Rollers – Both left & right sides.
7. Floor Rollers – Both left & right sides.
8. Tapered Rollers – Both left & right sides.

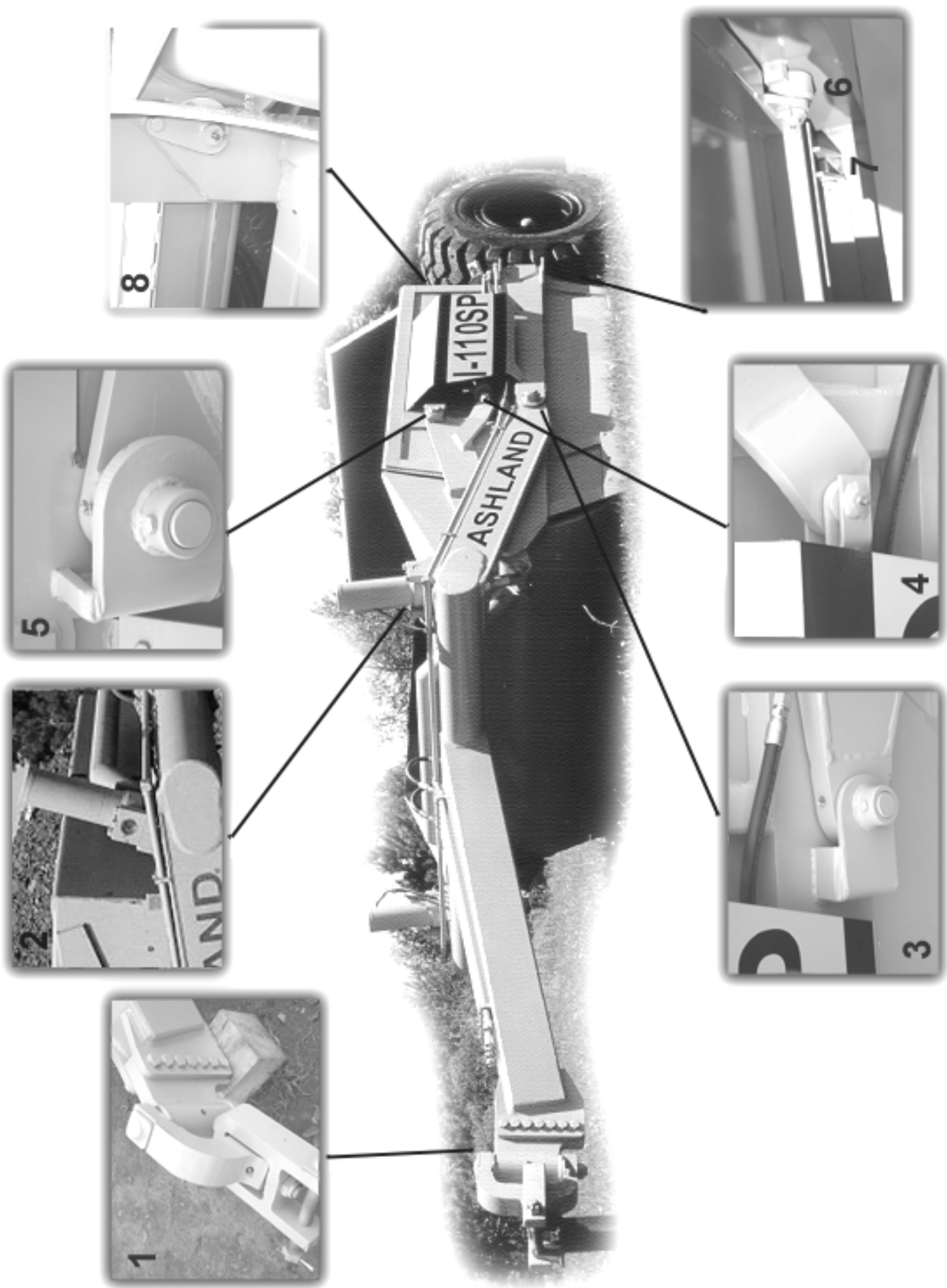

HYDRAULIC SYSTEM

Standard Two-Circuit Hydraulic Plumbing

The apron cylinders and the push-off cylinder are controlled on the same circuit with the sequence of the operation controlled by a sequence valve. The other hydraulic circuit controls the lift cylinders on the earthmover.

*To adjust the sequence valve, see Troubleshooting section.

Optional Three-Circuit Hydraulic Plumbing

The apron cylinders, push-off cylinder, and lift cylinders are all on separate hydraulic circuits.

PUSHING THE EARTHMOVER

The I-110TS was designed to be pushed when equipped with the optional push-bar. However, Ashland Industries, Inc. *STRONGLY* recommends using extreme caution when pushing the I-110TS earthmover to prevent any unnecessary damage.



CAUTION! The I-110TS earthmover must be pushed in a straight line with a maximum of a 100 hp dozer. Do not ram or jar the earthmover while pushing and push at a constant speed.



TROUBLESHOOTING

Introduction

With proper care and maintenance, the I-110TS will give many years of reliable service. When a situation arises where the earthmover performance is not satisfactory, this section will give some pointers on finding and correcting the problem.

Grease zerk will not take grease.

1. Grease zerk plugged.
 - a) Remove and replace grease zerk.
2. Pin is frozen.
 - a) Remove, clean, and inspect pin.
 - b) Replace pin if necessary.
3. Bushing grease passage is not aligned with grease zerk.
 - a) Remove, clean, inspect, and realign bushing.
 - b) Replace bushing if necessary and realign.

Push-off rollers do not roll.

1. The rollers need lubrication.
 - a) Check zerk hole and grease.
 - b) Remove pin, clean, inspect, and replace if necessary.
2. The roller bushing is worn out.
 - a) Remove roller assembly and replace bushing.
 - b) See parts manual.

Cylinders will not hold in preset position, i.e. the cylinder creeps.

1. Seals leaking internally.
 - a) Remove and replace seal kit.

Machine cuts unevenly.

1. Cutting edges worn unevenly.
 - a) Replace cutting edges.
2. Improperly inflated tires.
 - a) Check air pressure in tires.

Apron closes slowly

or

Apron and push-off are not working well together.

1. Sequence valve needs adjusting.
 - a) Remove acorn nut from end of sequence valve with a ½" wrench. Turn adjustment screw, using a 4mm hex wrench, clockwise until front apron rises before the push-off advances while the earthmover is empty. Turn the adjustment screw an additional ¼ turn clockwise, then replace the acorn nut and tighten.
 - b) Torque check valve assembly and int. pilot plug to 25 ft-lbs maximum.

CAUTION! Overtightening check valve assembly and int. pilot plug will cause internal damage to the sequence valve.



Note: Check valve assembly may leak slightly when torqued to 25 ft-lbs.



Limited Warranty Statement

Ashland Industries Inc. warrants each new product to be free from defects in material and workmanship. This warranty is applicable only for the normal service life expectancy of the product or components, not to exceed six consecutive months from the date of delivery of the new Ashland Industries product to the original purchaser, or the date the product is first put into service via a rental agreement or other means, whichever occurs first.

Genuine Ashland Industries Inc. replacement parts and components will be warranted for 30 days from date of purchase, or the remainder of the original equipment warranty period, whichever is longer.

Under no circumstances will it cover any merchandise or components thereof, which in the opinion of the company, has been subjected to misuse, unauthorized modification, alterations, an accident or if repairs have been made with parts other than those obtained through Ashland Industries Inc.

Ashland Industries Inc. in no way warrants Tires since these items are warranted separately by their respective manufacturer. Please call Ashland Industries Inc. to receive phone numbers of tire suppliers.

Ashland Industries Inc. in no way warrants wearable items such as cutting edges, front dolly wheel balls, socket halves.

Our obligation under this warranty shall be limited to repairing or replacing, free of charge to the original purchaser, any part that, in our judgement, shall show evidence of such defect, provided further that such part shall be returned within 30 days from the date of failure to Ashland Industries Inc. routed through the dealer and distributor from whom the purchase was made, transportation charges prepaid. Upon warranty approval proper credits will be reimbursed for transportation.

This warranty shall not be interpreted to render Ashland Industries Inc. liable for injury or damages of any kind or nature to person or property. This warranty does not extend to the loss revenue, extra labor cost associated with downtime, substitute machinery, rental or for any other reason.

Except as set forth above, Ashland Industries Inc. shall have no obligation or liability of any kind on account of any of its equipment and shall not be liable for special or consequential damages. Ashland Industries Inc. make no other warranty, expressed or implied, and, specifically, Ashland Industries Inc. disclaims any implied warrant or merchantability or fitness for a particular purpose. Some states or provinces do not permit limitations or exclusions of implied warranties or incidental or consequential damages, so the limitations or exclusion in this warranty may not apply.

This warranty is subject to any existing conditions of supply which may directly affect our ability to obtain materials or manufacture replacement parts.

Ashland Industries Inc. reserves the right to make improvements in design or changes in specifications at any time, without incurring any obligation to owners of units previously sold

No one is authorized to alter, Modify or enlarge this warranty nor the exclusion, limitations and reservations.

Ashland Industries Inc.
Warranty Department