

Ashland **INDUSTRIES, INC.™**

*Quality
Equipment
Since
1953*

I-110-SP PARTS MANUAL

Version 3-03



Ashland Industries Inc.
1115 Rail Drive
P.O. Box 717
Ashland, WI. 54806
Ph: 877-634-4622 *Toll Free*
Ph: 715-682-4622
Fx: 715-682-9717
www.ashlandind.com

MEMBER
CIMA
CONSTRUCTION INDUSTRY
MANUFACTURERS ASSOCIATION





HOW TO ORDER PARTS:

IMPORTANT

Parts must be ordered through your local authorized ASHLAND dealer.

Be sure to state MODEL and SERIAL NUMBER of your machine, PART NUMBER, DESCRIPTION and QUANTITY needed.

Unless this is done, we cannot provide prompt service or assure shipment of the correct parts.

INDEX

Page 3.	Operators and Maintenance Instructions
Page 4.	Safety Guidelines
Page 5.	Illustration and Parts List - Swivel Hitch
Page 6.	Illustration and Parts List - Front End Assembly
Page 7.	Illustration and Parts List - Apron Assembly
Page 8.	Illustration and Parts List - Bowl and Frame
Page 9.	Illustration and Parts List - Pushoff Gate Assembly
Page 10.	Illustration and Parts List - Rear Wheel and Hub Assembly
Page 11.	Illustration and Parts List - Apron Cylinder 4" X 13"
Page 12.	Illustration and Parts List - Lift Cylinder 5" x 16"
Page 13.	Illustration and Parts List - Pushoff Cylinder 4" x 54"
Page 14.	Illustration and Parts List - Pushoff Cylinder 4-1/2" x 54" Optional
Page 15-16	Illustration and Parts List - Pushoff Cylinder 5" x 54" Optional
Page 17-21	Service Manual Appendix
Page 22-24	Troubleshooting
Page 25.	Warranty Statement

OPERATORS AND MAINTENANCE INSTRUCTIONS

This scraper is a durable piece of equipment and with proper care will yield many years of trouble free operation. The scraper requires a power source with TWO 4 way (double acting) hydraulic control valves.

The scraper should be greased at all points where grease fittings are provided. Connect hydraulic hoses to the tractor and retract lift cylinders to REMOVE TRANSPORT LOCK PINS (point A), then extend and retract all cylinders several times to force out any air from the hydraulic cylinders and lines. Check the oil levels in the tractor hydraulic system and add to maintain the proper level. Care should be used when adding oil or when disconnecting any oil line to keep all dirt out of the oil as dirt is a major factor in the failure of hydraulic components.

When the scraper is placed into operation, the operator will have to "feel out" the amount of depth of cut to obtain maximum loading efficiency. This is usually accomplished by taking a lesser and more uniform cut; however, some soil conditions such as loose sand may require a "pumping action" obtained by taking successive deep cuts and lifting out of cut as the tractor begins to lose power or traction.

1. After 10 hours work, all bolts should be checked and tightened if necessary.
2. Every 10 hours all grease fittings should be lubricated.
3. After 50 hours work, all bolts should be rechecked and tightened if necessary. Check wheel bearings and adjust if necessary.
4. After 300 hours work, clean and repack wheel bearings and replace, if necessary, cutting edges, worn pins, etc.
5. Tighten all wheel bolts after first two hours use. Check daily for two weeks. Keep torqued to 450 ft. lbs..
6. Maintain tire pressure at 35 to 40 psi on a rear unit, 40-50 on a front unit.



SAFETY SIGNAL WORDS

Note the use of the signal words DANGER, WARNING and CAUTION with the safety messages. The appropriate signal word for each has been selected using the following guidelines:

 **DANGER:** Indicates an imminently hazardous situation that, if not avoided, will result in death or serious injury. This signal word is to be limited to the most extreme situations typically for machine components which, for functional purposes, cannot be guarded.

 **WARNING:** Indicates a potentially hazardous situation that, if not avoided, could result in death or serious injury, and includes hazards that are exposed when guards are removed. It may also be used to alert against unsafe practices.

 **CAUTION:** Indicates a potentially hazardous situation that, if not avoided, may result in minor or moderate injury. It may also be used to alert against unsafe practices.



GENERAL SAFETY GUIDELINES

Safety of the operator is one of the main concerns in designing and developing a new piece of equipment. Designers and manufacturers build in as many safety features as possible. However, every year many accidents occur which could have been avoided by a few seconds of thought and a more careful approach to handling equipment. You, the operator, can avoid many accidents by observing the following precautions in this section. To avoid personal injury, study the following precautions and insist those working with you, or for you, follow them.

Replace any CAUTION, WARNING, DANGER or instruction safety decal that is not readable or is missing. Location of such decals is indicated in this booklet.

Do not attempt to operate this equipment under the influence of drugs or alcohol.

Review the safety instructions with all users annually.

This equipment is dangerous to children and persons unfamiliar with its operation. The operator should be a responsible adult familiar with farm machinery and trained in this equipment's operations. Do not allow persons to operate or assemble this unit until they have read this manual and have developed a thorough understanding of the safety precautions and of how it works.

To prevent injury or death, use a tractor equipped with a Roll Over Protective System (ROPS). Do not paint over, remove or deface any safety signs or warning decals on your equipment. Observe all safety signs and practice the instructions on them.

Never exceed the limits of a piece of machinery. If its ability to do a job, or to do so safely, is in question - DON'T TRY IT.

SWIVEL HITCH ASSEMBLY I-110 SP

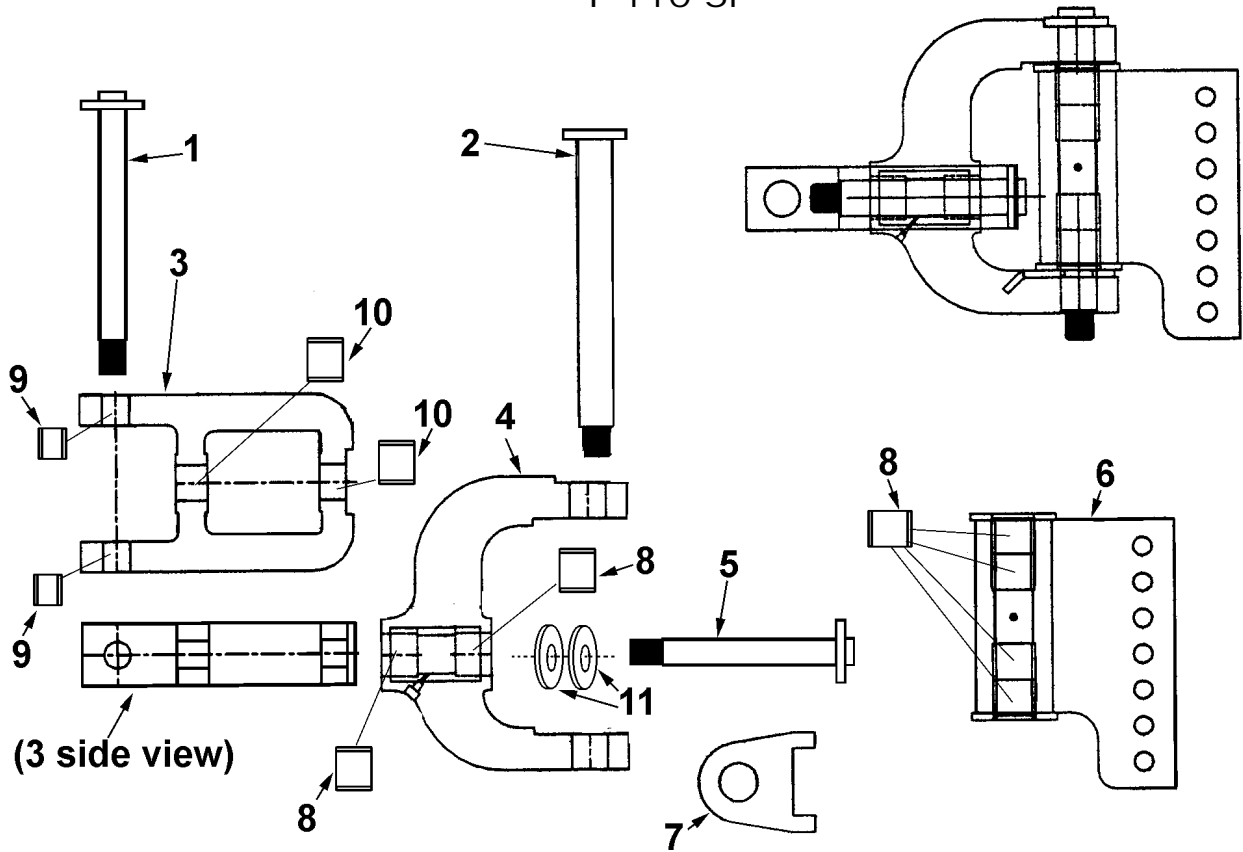

KEY NO.	PART NO.	DESCRIPTION
1.	A123299-08	Pin: Four Ear Drawbar To Hitch
	A123299-07	Pin: Two Ear Drawbar To Hitch
	AFN-00014	Nut: 1-1/2" NC Slotted
2.	A123299-06	Pin: Sq. Tab Head 2 X 18-1/2"
	AFN-00018	Nut: 1-1/2" NF Top Lock
3.	A123299-03R	A-Frame Hitch
4.	A123299-02	C-Frame Hitch: Offset
5.	A123299-05	Pin: Sq. Tab Head 1-1/2 X 12-1/2"
	AFN-00018	Nut: 1-1/2" NF Top Lock
6.	A123299-01	Vertical Mounting Tube: 7 Hole
7.	A123299-04	Wear Pad With Locking Legs
8.	ABS-00001	Bushing: 2-3/8" OD x 2" ID
9.	A123299-09	Bushing: 2" OD x 1-1/2" ID x 1-1/2" (2 req'd)
10.	A123299-10	Bushing: 2-3/8" OD x 2" ID x 1-1/2" (2 req'd)
11.	A123299-11	Hardened Washer, 2" (2 req'd)

FRONT END

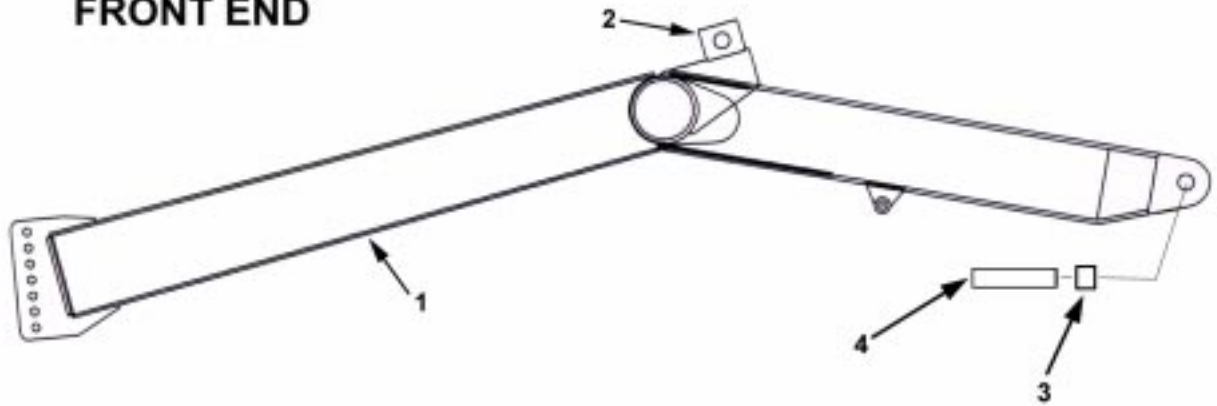

KEY NO.	PART NO.	DESCRIPTION
1.	A123292	Front End Assembly
2.	A123293A	Trunion Mount Block
3.	A14039	Bushing, 2-3/8" OD x 2" ID x 2" Long with Grease Passage
4.	A10152A	Frame Attachment Pin, 2" x 8-1/16"

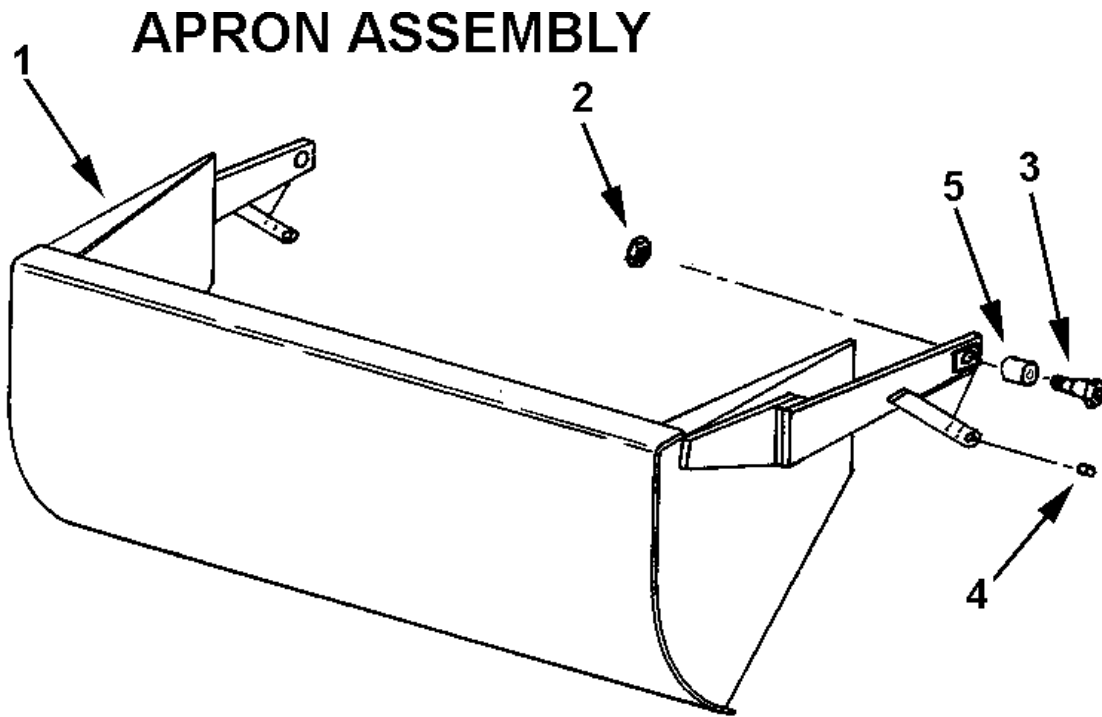

I-130-apron

KEY NO.	PART NO.	DESCRIPTION
1	A10154	Apron
2	AFN-00018	Self lock nut, 1-1/2" NF
3	AFB-00038	Bolt, 1-1/2" NF x 6" lg, s/n 17806 & up
4	A10155	Bushing, 1-1/2" OD x 1-1/2" ID x 1" long
5	A16027	Bushing, 2" OD x 1-1/2" ID x 2" long, s/n 17806 & up

BOWL AND FRAME ASSEMBLY

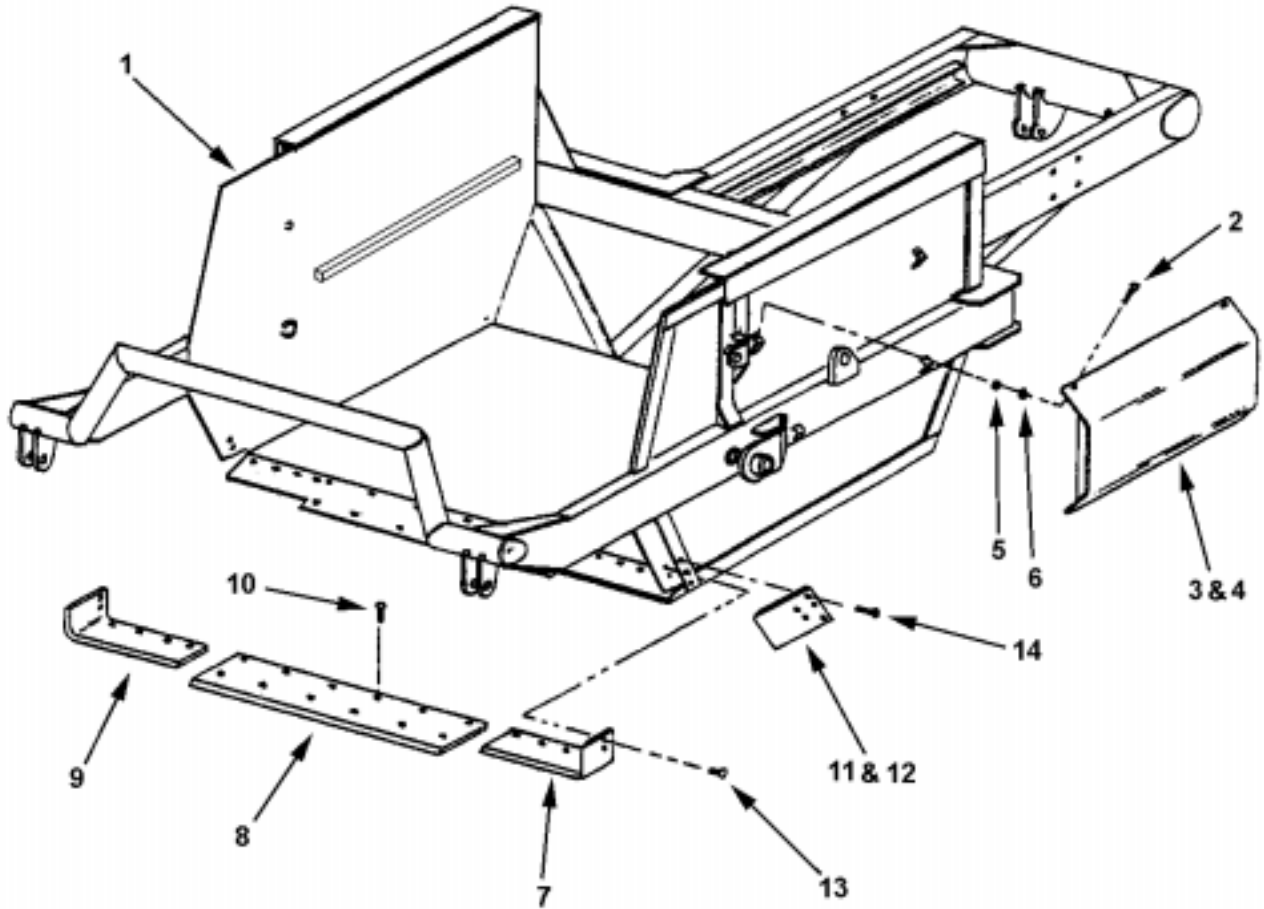

110-130 bowl

KEY NO.	PART NO.	DESCRIPTION
1	A123302B	Bowl and Frame I-110SP
2	6835	Bolt, 3/8" NC x 1"
3	A10157	Left hand cylinder guard
4	A10158	Right hand cylinder guard
5	8078	3/8" Lockwasher
6	7450	Nut, 3/8" NC
7	A10011A	Left cutting edge, 8"
8	A10012A	Center cutting edge, 12" x 54"
9	A10010A	Right cutting edge, 8"
10	PB8P-NC-063-0250	Plow bolt, 5/8" NC x 2-1/2" (12 req'd)
11	A14031A	(Optional) Left Bank Shaver Side Blade (s/n 17582 +)
12	A14032A	(Optional) Right Bank Shaver Side Blade (s/n 17582 +)
13	PB8P-NC-063-0200	Plow bolt, 5/8" NC x 2" (6 req'd / blade)
14	PB8P-NC-063-0250	Plow Bolt, 5/8" NC x 2-1/2" (7 req'd / blade)
10, 13, 14	7530	Nuts for Plow Bolts: 5/8" NC (25 req'd total)

PUSH OFF GATE ASSEMBLY

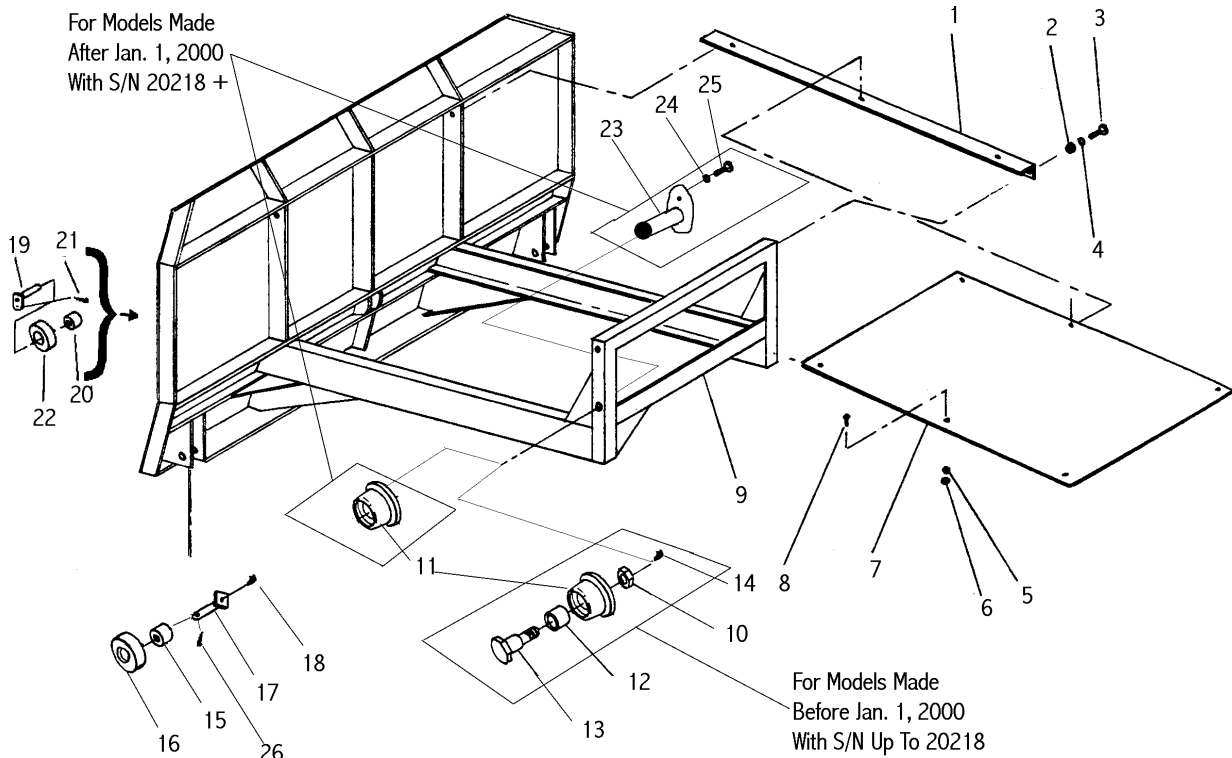

KEY NO.	PART NO.	DESCRIPTION
1.	A10159	Brace (L.H. & R. H. same)
2.	AFN-00006	Nut: 3/4" NC
3.	AFB-00037	Bolt: 3/4" NC x 2" Lg.
4.	AFW-00002	Lockwasher: 3/4"
5.	8078	Lockwasher: 3/8"
6.	7450	Nut: 3/8" NC
7.	A10171	Dirt Shield
8.	AFB-00034	Bolt: 3/8 NC x 1" Lg.
9.	A10160	Pushoff Gate: Model I-110 SP
10.	AFN-00024	Jam Nut: 1-1/4" NF
11.	A123306	Roller: Rear Gate
12.	A123307	Bushing" 1-5/8" OD x 1-1/4" ID
13.	A10008	Pin: Shoulder 1-5/8" to 1-1/4" Zerk in Thread
14.	14505	Grease Fitting: 1/8" NPT
15.	A10163	Bushing: 1-3/4" OD x 1-1/4" ID
16.	A10164	Roller: 4-1/4 OD X 1-3/4 ID
17.	A6007A	Pin: 1-1/4" x 4-1/8" Lg.
18.	AHF-00028	Grease Fitting: 1/8" NPT -90 degree
19.	A123288	Pin: 1-1/4 X 3-1/4" Tab Head
20.	A10163	Bushing: 1-3/4" OD x 1-1/4" ID
21.	7036	Bolt: 1/2 NC X 2"
22.	A10164	Roller: 4-1/4 OD X 1-3/4 ID
23.	A123305	Pin: 1-1/4 X 2-3/4"
24.	8100	Lockwasher: 1/2"
25.	AFB-00033	Bolt: 1/2 NC X 2-1/2"
26.	AFP-00001	Cotter Pin: 1/4 X 3-1/2"

REAR WHEEL, SPINDLE & HUB ASSEMBLY

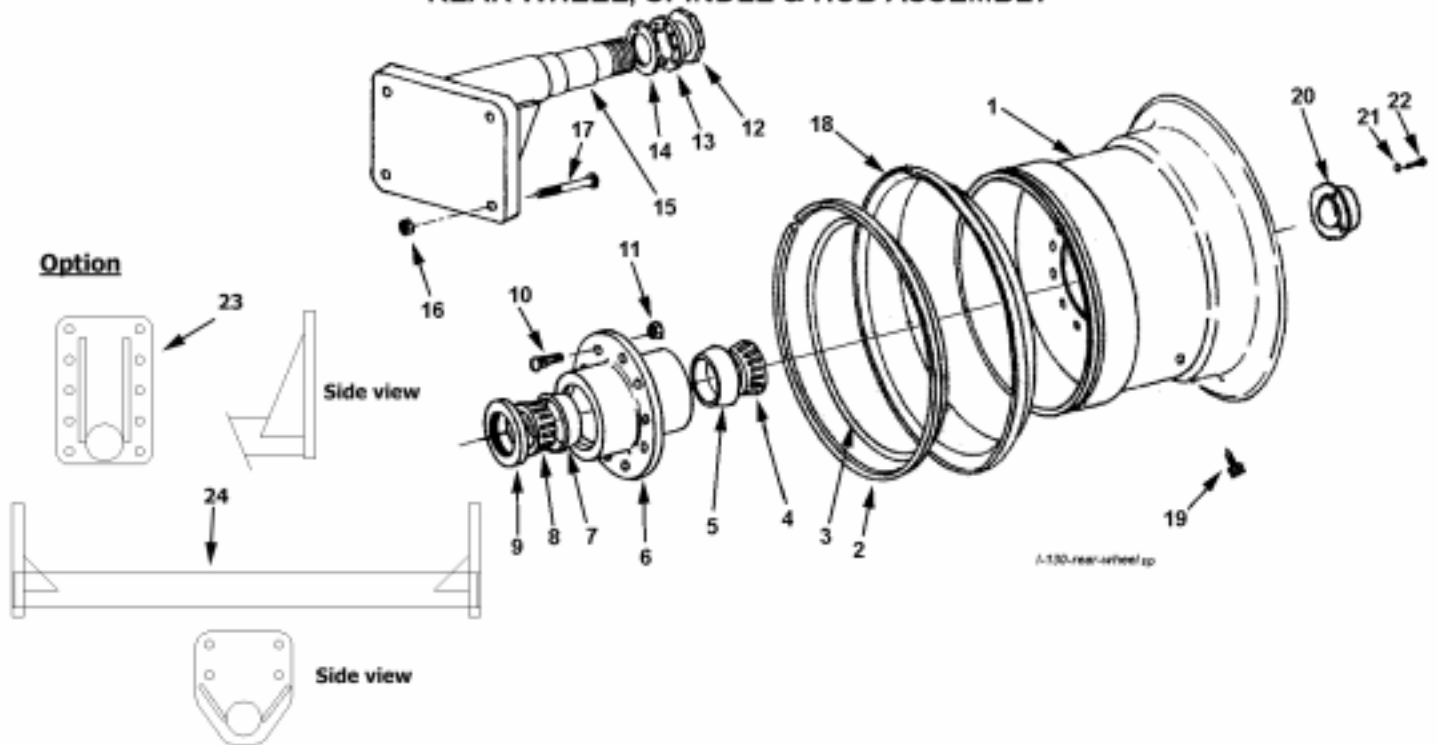

KEY NO.	PART NO.	DESCRIPTION
1	A14035	Wheel - 17" x 25"
2	A14008	O-Ring
3	A14038	Lock Ring
4	A14015	Bearing cone (Timken 644)
5	A14014	Bearing cup (Timken 632)
6	A14010	Hub
7	A14013	Bearing cup (Timken 742)
8	A14012	Bearing cone (Timken 749)
9	A14011	Grease seal (CR 42624)
10	A10176	Stud
11	A10046	Lug nut
12	A10048	Spindle nut
13	A10049A	Lock collar
14	A10172	Nut w/ lock pin
15	A14037	Spindle
16	AFN-00001	Nut, 1" NF Toplock
17	AFB-00017	Bolt, 1" NF x 6-1/2" lg.
18	A14036	Slide Ring
19	A14016	Valve Stem
20	A14004	Hub Cap
21	8070	Lockwasher, 5/16"
22	AFB-00026	Bolt, 5/16" NC x 5/8" lg.
23	A14037E	Extended spindle plate (Option)
24	A14037P	Cross pipe

HYDRAULIC CYLINDER 4" x 13" A413H1 APRON CIRCUIT, LEFT AND RIGHT SIDE

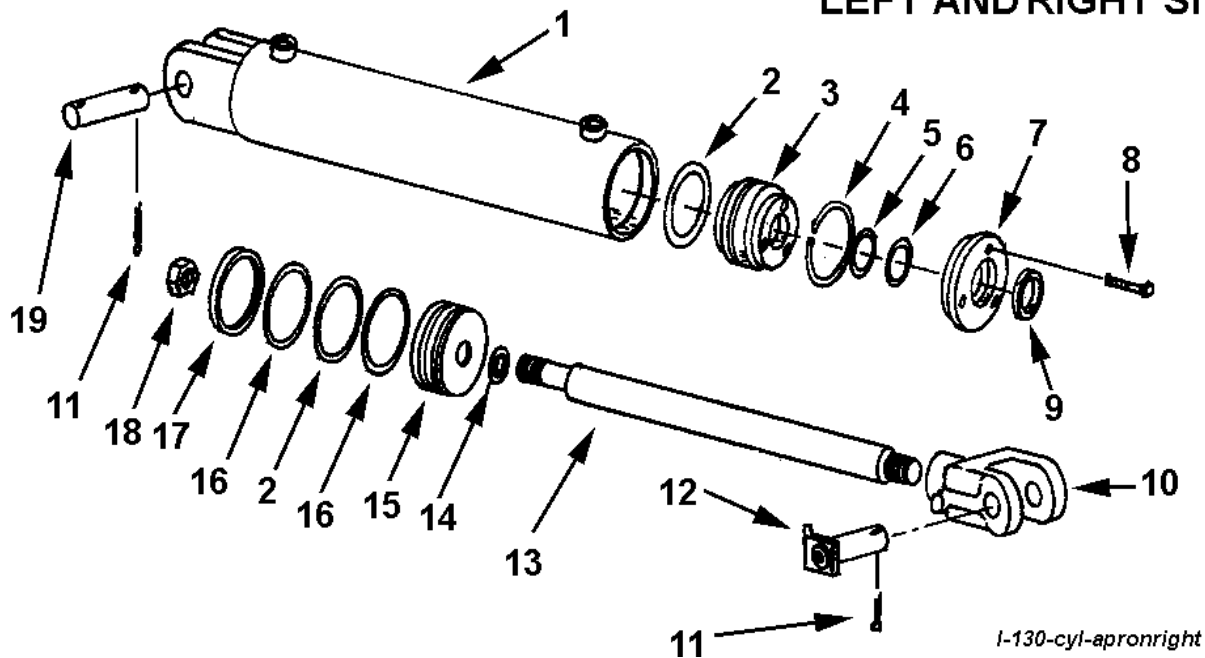

for s/n 17863 & up

KEY NO.	PART NO.	DESCRIPTION
1	A175H01	Barrel Assembly
2	A300H06	O-ring seal, 4" OD x 3/16"
3	A300H11	Head gland
4	A300H12	Retainer ring
5	A22H15	O-ring, 1-1/2" x 1/8"
6	A22H15A	Backup washer
7	A300H13	Head cap
8	A22H18	Capscrew, 1/4 NC x 1"
9	A22H17	Wiper seal, 1-1/2" ID
10	A12H03	Clevis end
11		Cotter pin, 3/16" x 1-1/2"
12	A10167	Pin, 1" x 3-1/16"
13	A175H02	Shaft, 1-1/2" diameter
14	A45H05	Piston gasket, 1"
15	A300H07	Piston, 4" dia.
16	A300H05	Back up washer, 4" OD
17	A300H04	Cast iron ring, 4" OD
18	A300H03	Piston nut, 1" NF
19	A1217	Pin, 1" x 3-1/2"
	A300H14B	Packing kit containing:
		1 - A300H04 2 - A22H15 2 - A300H05
		1 - A22H15A 2 - A22H06 1 - A22H17
		1 - A45H05

**LIFT CYLINDER
5" x 16" TRUNION MOUNT
PART NO. A123324**

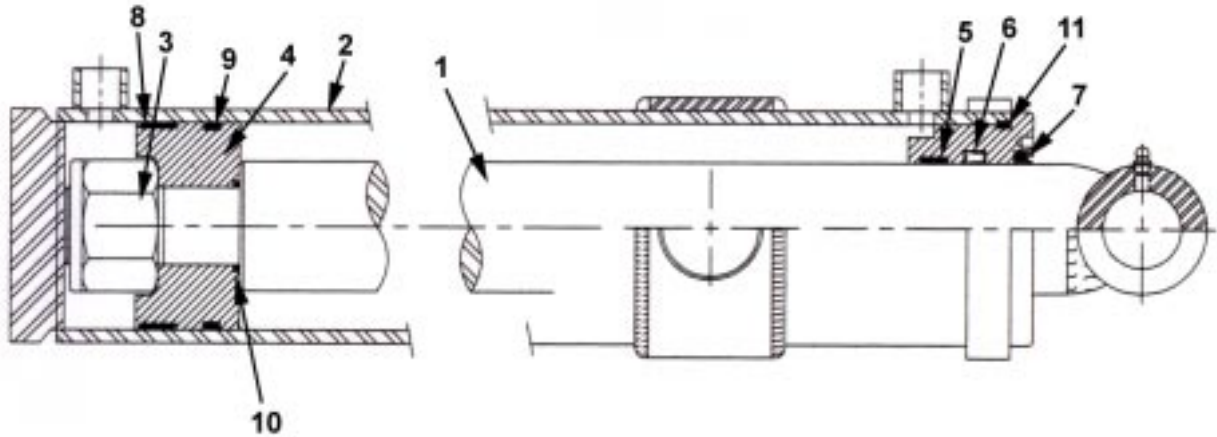

KEY NO.	PART NO.	DESCRIPTION
1	A123324-1	2-1/2" Rod
2	A123324-2	Barrel Weldment
3	A123324-3	Lock Nut 1-1/2"-12
4	A123324-4	Piston
5	A123324-5	Gland
6	A123324-6	Rod Seal
7	A123324-7	Rod Wiper
8	A123324-8	Wear Ring
9	A123324-9	Piston Seal (2-pc.)
10	A123324-10	O-ring
11	A123324-11	O-ring
	AHS-00140	Seal Kit (Items 6-11)

I-110 PUSH GATE CYLINDER ASSEMBLY PART NO. A454H114B
4" BORE X 54" STROKE - STANDARD

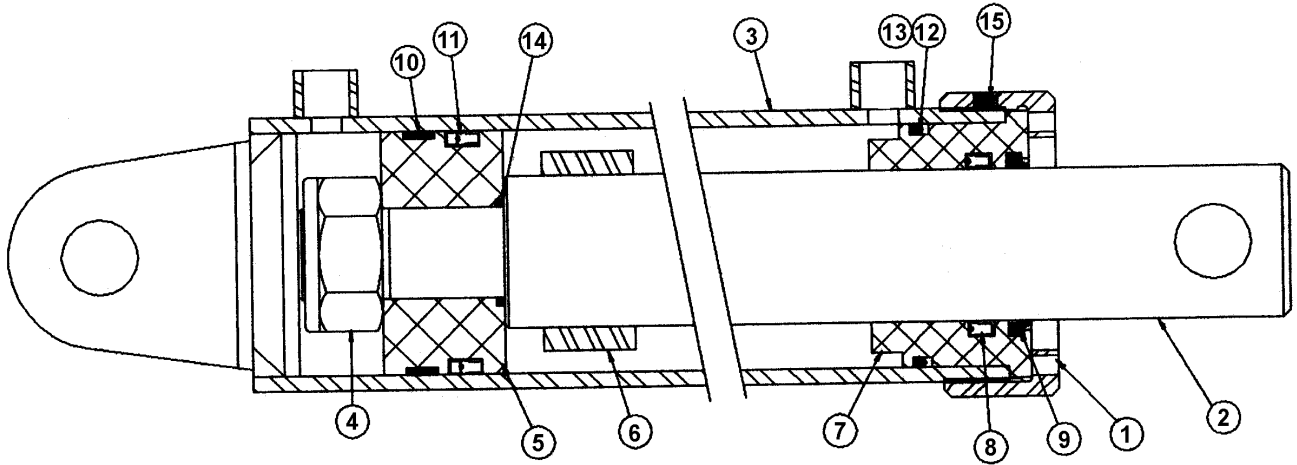

I-110-cyl-push

KEY NO.	QTY.	PART NO.	DESCRIPTION
1	1	A101H103	Collar
2	1	A101H98	2 1/2" Rod
3	1	A101H97	Barrel weldment
4	1		Lock nut (1 1/2" - 12)
5	1	A101H96	Piston
6	1	A101H99	Spacer
7	1	A101H102	Head
8	1	A140H07	Rod seal
9	1	A140H08	Rod wiper
10	1	A101H100	Wear ring
11	1	A101H101	Piston seal
12	1	A200H06	O-ring
13	1	A300H05	Backup ring
14	1	A22H15	O-ring
15	1		Nylon tip set screw (3/8" NC x 3/8)
16	1	A101H30A	Seal kit (Items 8-14)

I-1 0 PUSH GATE CYLINDER ASSEMBLY PART NO. A455H114

4 1/2" BORE X 54" STROKE

OPTIONAL

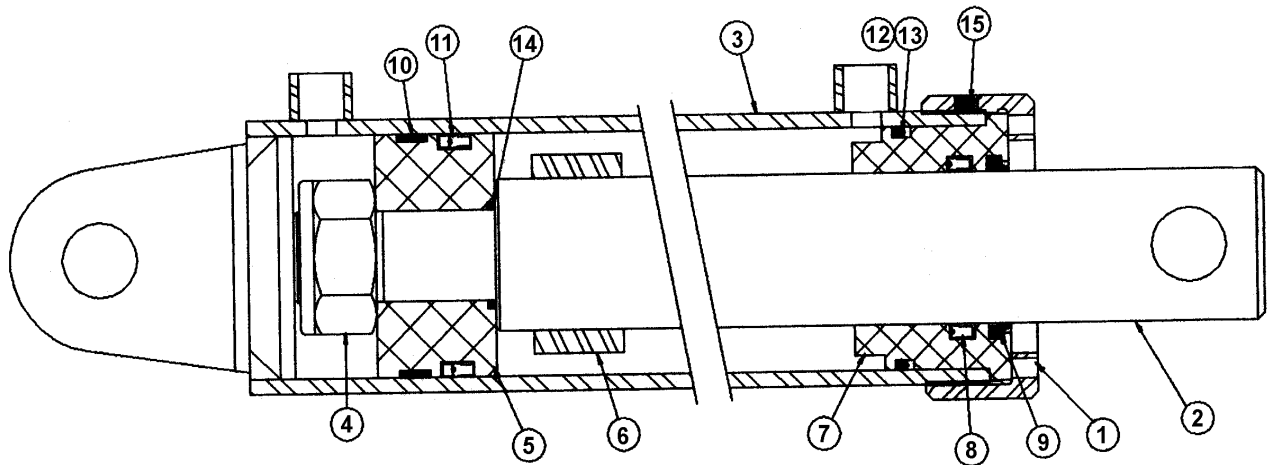

I-130-cyl-push

KEY NO.	QTY.	PART NO.	DESCRIPTION
1	1	A175H10	Collar
2	1	A130H30	2 1/2" Rod
3	1	A130H29	Barrel weldment
4	1	A140H13	Lock nut (2" - 12)
5	1	A175H12	Piston
6	1	A17506	Spacer
7	1	A175H09	Head
8	1	A140H07	Rod seal
9	1	A140H08	Rod wiper
10	1	A175H07	Wear ring
11	1	A175H05	Piston seal
12	1	A175H03	O-ring
13	1	A175H04	Backup ring
14	1	A140H14	O-ring
15	1		Nylon tip set screw (3/8" NC x 3/8)
16	1	A175H15	Seal kit (Items 8-14)

MODEL I-110 SP
PUSHOFF CYLINDER 5 X 54" - OPTIONAL
PART NO. A554H114A

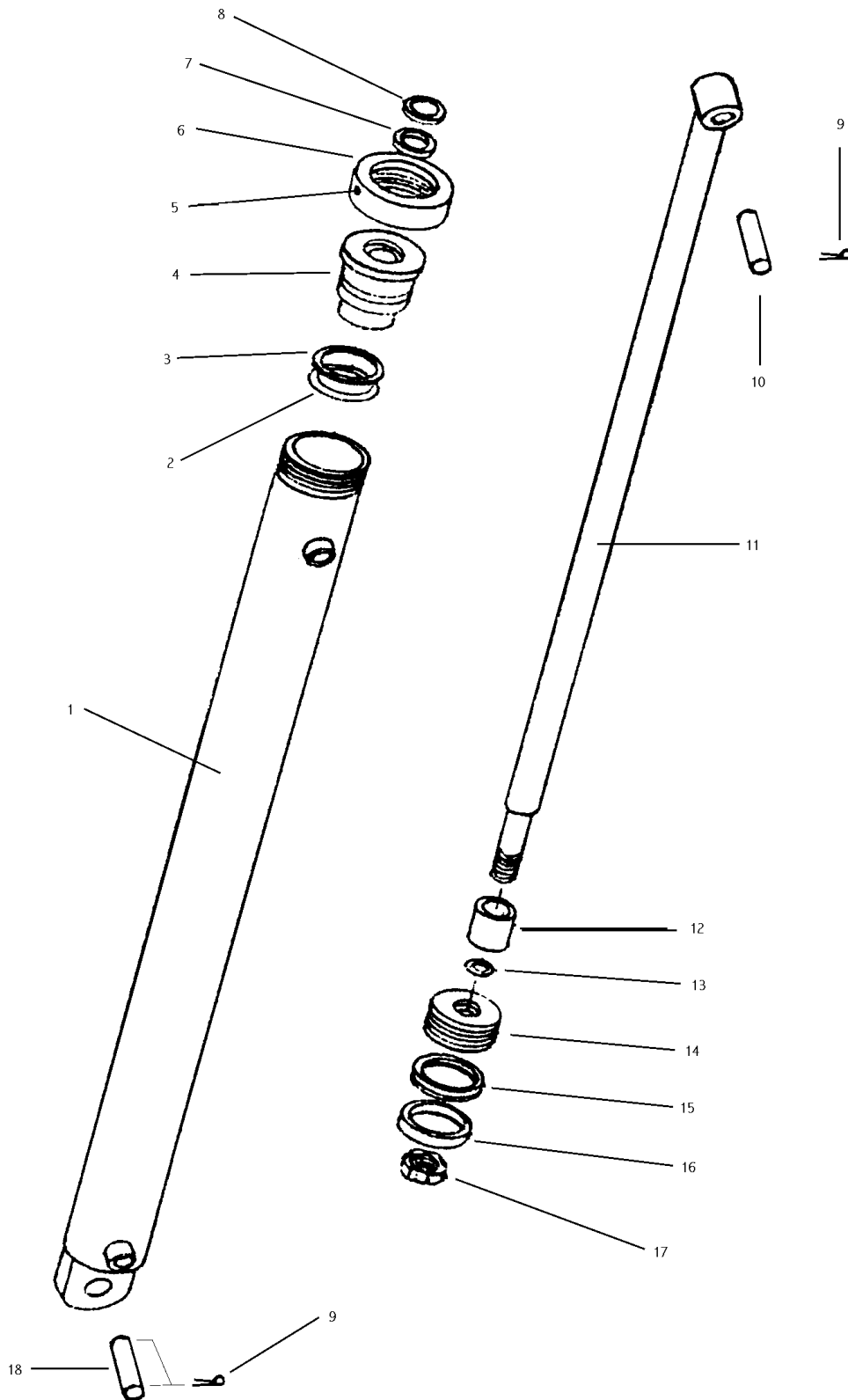

MODEL I-110 SP
 PUSHOFF CYLINDER 5 X 54" - OPTIONAL
 PART NO. A554H114A

KEY NO.	PART NO.	DESCRIPTION
1.	A123324	Barrel Assembly: 5" Bore
2.	A400H06	O-Ring: 5" OD X 4-1/2" ID
3.	A400H05	Back Up Washer: 5" OD X 4-1/2" ID
4.	A140H21	Head Gland: 5"
5.	-----	Set Screw: 3/8" NC
6.	A140H19	Collar
7.	A140H07	Shaft Seal: 2-1/2" ID X 3" OD OU-Cup
8.	A140H08	Wiper Seal: 2-1/2" ID X 2-15/16" OD
9.	8602	Cotter Pin: 1/4" X 2"
10.	A14033	Pin: 1-1/4" Dia. X 5" Lg.
11.	A130H30	Shaft: 2-1/2" Dia.
12.	A175H06	Spacer
13.	A22H15	O-Ring: 1-1/2" x 1-3/4" OD
14.	A140H22	Piston: 5"
15.	A140H24	Piston Seal: 5" OD X 4-1/4" ID
16.	A140H25	Wear Ring: 5" OD
17.	AFN-00018	Lock Nut: 1-1/2" NF
18.	A9024	Pin: 1-1/4" x 4-3/4"
	A140H28	Packing Kit: Containing:
		(1) A140H25 (1) A400H06
		(1) A140H07 (1) A140H08
		(1) A22H15 (1) A400H05
		(1) A140H24

MAINTENANCE CHECKLIST

1. Grease all zerks.
 - a) Every 8 hours of operation.
 - b) See Lubrication Points section on next page.

2. Greasing the hubs.
 - a) Re-pack wheel bearings after 600 hrs of operation.
 - b) Completely clean grease out of hub and bearings every 1200 hours of operation.

3. Check tire pressure.
 - a) 20.5 - 25, 12-ply tire requires a tire pressure of 35-40 psi on a rear machine, 40-50 on a front machine..

4. Check all pins for signs of wear.
 - a) Daily

5. Check wheel lug nut torque.
 - a) After first 2 hours of operation.
 - b) Recheck daily for next 2 weeks.
 - c) Tighten wheel lug nuts in a star pattern.
 - d) Torque wheel lug nuts to 450 ft-lbs.

6. Check and retighten all bolts.
 - a) After initial 10 hours of use.
 - b) Again after 50 hours of use.
 - c) See Torque Specifications on next page.

7. Inspect cutting edges.
 - a) Daily
 - b) Replace cutting edges when center blade has been worn to approximately 6" and side edges worn to approximately 4".



CAUTION! Failure to replace worn cutting edges may result in unnecessary wear to the earthmover sides and floor.

Note: Please specify left or right "L" shaped cutting edges when ordering replacements.

TORQUE SPECIFICATIONS

<i>Grade 8</i>	
<i>Bolt</i>	<i>Torque</i>
<i>Diameter</i>	<i>ft-lbs</i>
1/4"	12
5/16"	25
3/8"	45
7/16"	70
1/2"	110
9/16"	150
5/8"	220
3/4"	380
7/8"	600
1"	900
1-1/8"	1280
Lug Nuts	750

LUBRICATION

1. Grease all zerks every 8 hrs of operation with high quality, general-purpose grease.
 - a) Grease until grease flows from around pin.

Lubrication Points (*see Ill. on next page*)

1. Hitch – Horizontal and vertical pins.
2. Lift Cylinders – Rod end & Trunion; Both left & right sides.
3. Front Arm Pivot Joint – Both left & right sides.
4. Apron Cylinders – Rod clevis pin; Both left & right sides.
5. Apron Pivot Pin – Both left & right sides.
6. Hold-down Rollers – Both left & right sides.
7. Floor Rollers – Both left & right sides.
8. Tapered Rollers – Both left & right sides.

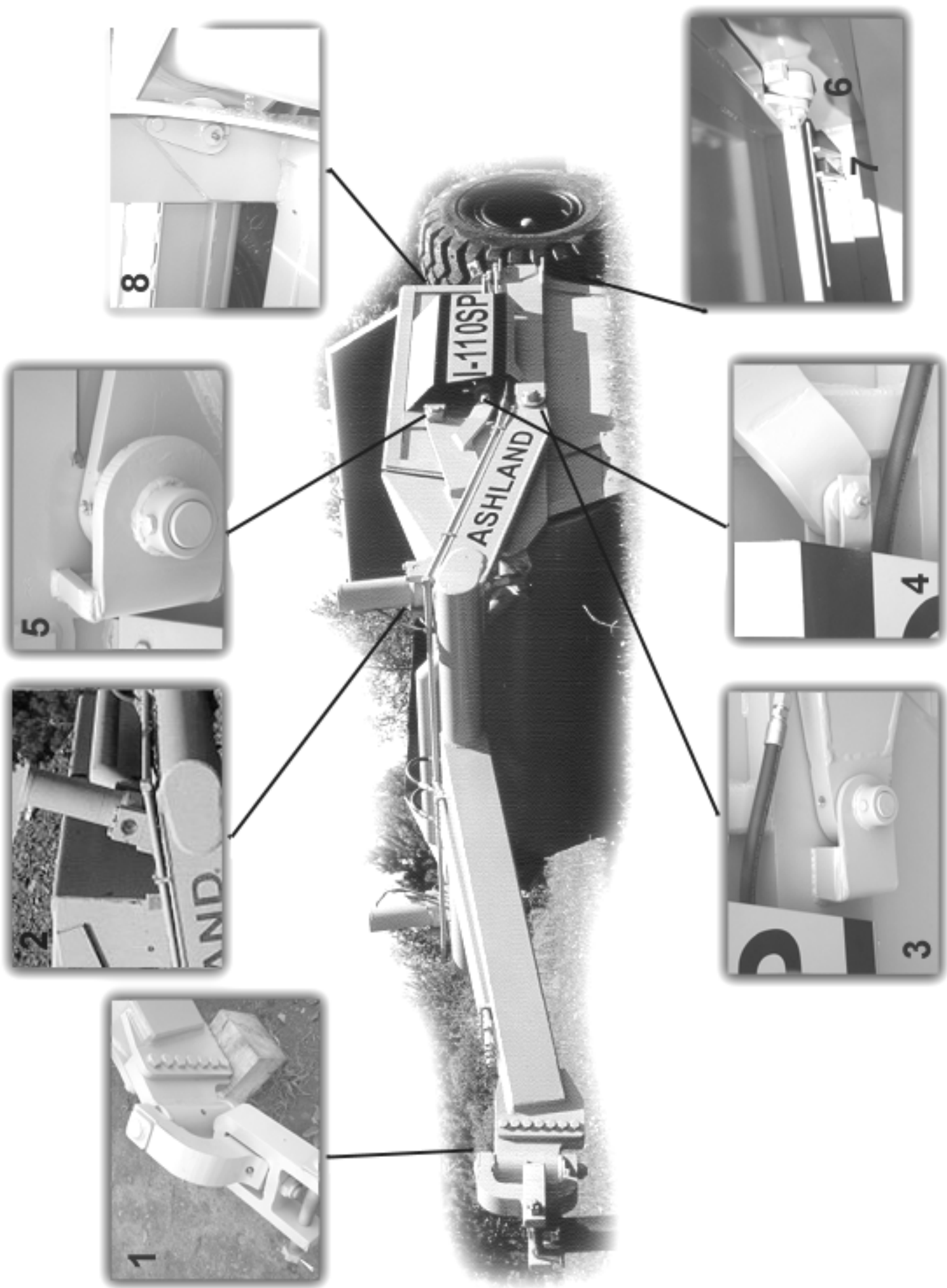

HYDRAULIC SYSTEM

Standard Two-Circuit Hydraulic Plumbing

The apron cylinders and the push-off cylinder are controlled on the same circuit with the sequence of the operation controlled by a sequence valve. The other hydraulic circuit controls the lift cylinders on the earthmover.

*To adjust the sequence valve, see Troubleshooting section.

Optional Three-Circuit Hydraulic Plumbing

The apron cylinders, push-off cylinder, and lift cylinders are all on separate hydraulic circuits.

Push-off Cylinder Hydraulic System

A pressure relief valve, in both two-circuit and three-circuit hydraulic plumbing, protects the pushoff cylinder hydraulic system. This pressure relief valve is designed to limit the hydraulic oil pressure delivered to the push-off cylinder. This valve is preset from the factory at 2000 psi.

*To adjust the pressure relief valve, see Troubleshooting section.

PUSHING THE EARTHMOVER

The I-110SP was designed to be pushed when equipped with the optional push-bar. However, Ashland Industries, Inc. *STRONGLY* recommends using extreme caution when pushing the I-110SP earthmover to prevent any unnecessary damage.



CAUTION! The I-110SP earthmover must be pushed in a straight line with a maximum of a 100 hp dozer. Do not ram or jar the earthmover while pushing and push at a constant speed.



TROUBLESHOOTING

Introduction

With proper care and maintenance, the I-110SP will give many years of reliable service. When a situation arises where the earthmover performance is not satisfactory, this section will give some pointers on finding and correcting the problem.

Grease zerk will not take grease.

1. Grease zerk plugged.
 - a) Remove and replace grease zerk.
2. Pin is frozen.
 - a) Remove, clean, and inspect pin.
 - b) Replace pin if necessary.
3. Bushing grease passage is not aligned with grease zerk.
 - a) Remove, clean, inspect, and realign bushing.
 - b) Replace bushing if necessary and realign.

Push-off rollers do not roll.

1. The rollers need lubrication.
 - a) Check zerk hole and grease.
 - b) Remove pin, clean, inspect, and replace if necessary.
2. The roller bushing is worn out.
 - a) Remove roller assembly and replace bushing.
 - b) See parts manual.

Cylinders will not hold in preset position, i.e. the cylinder creeps.

1. Seals leaking internally.
 - a) Remove and replace seal kit.

Machine cuts unevenly.

1. Cutting edges worn unevenly.
 - a) Replace cutting edges.
2. Improperly inflated tires.
 - a) Check air pressure in tires.

Push-off cylinder stalls during ejection process.

1. Adjust pressure relief valve bypass pressure.
 - a) Remove the acorn nut from the end of the pressure relief valve with a $\frac{1}{2}$ " wrench to expose the adjustment screw. Turn the adjustment screw, using a 4mm hex wrench, clockwise to increase pressure and counter-clockwise to decrease pressure. Use a pressure gauge in the hydraulic line as shown, to set the pressure.

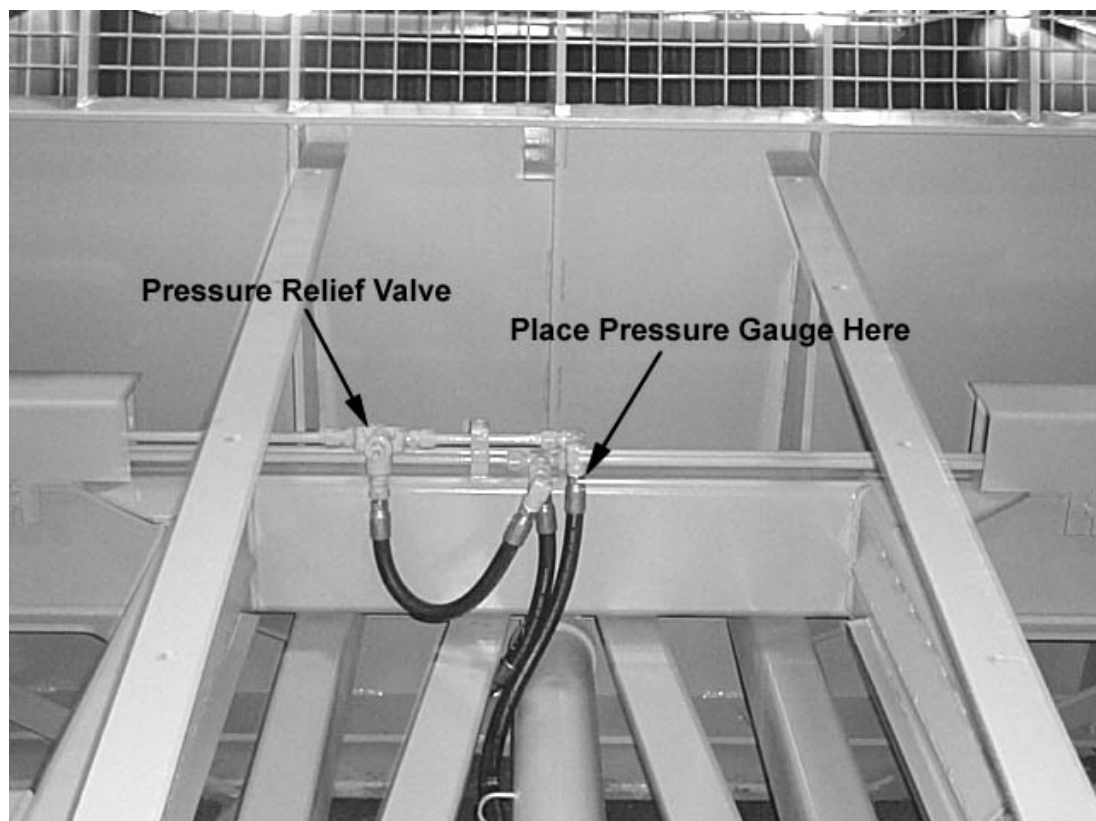

Apron closes slowly

or

Apron and push-off are not working well together.

1. Sequence valve needs adjusting.
 - a) Remove acorn nut from end of sequence valve with a ½" wrench. Turn adjustment screw, using a 4mm hex wrench, clockwise until front apron rises before the push-off advances while the earthmover is empty. Turn the adjustment screw an additional ¼ turn clockwise, then replace the acorn nut and tighten.
 - b) Torque check valve assembly and int. pilot plug to 25 ft-lbs maximum.



CAUTION! Overtightening check valve assembly and int. pilot plug will cause internal damage to the sequence valve.

* Note: Check valve assembly may leak slightly when torqued to 25 ft-lbs.

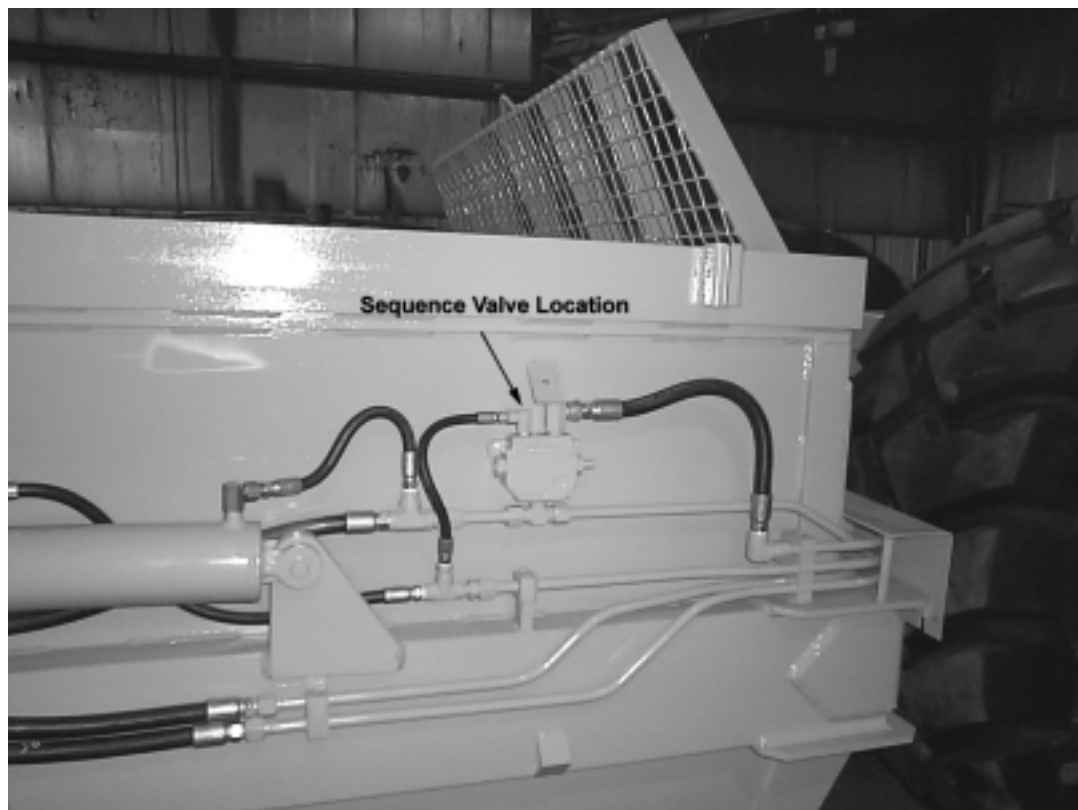

Limited Warranty Statement

Ashland Industries Inc. warrants each new product to be free from defects in material and workmanship. This warranty is applicable only for the normal service life expectancy of the product or components, not to exceed six consecutive months from the date of delivery of the new Ashland Industries product to the original purchaser, or the date the product is first put into service via a rental agreement or other means, whichever occurs first.

Genuine Ashland Industries Inc. replacement parts and components will be warranted for 30 days from date of purchase, or the remainder of the original equipment warranty period, whichever is longer.

Under no circumstances will it cover any merchandise or components thereof, which in the opinion of the company, has been subjected to misuse, unauthorized modification, alterations, an accident or if repairs have been made with parts other than those obtained through Ashland Industries Inc.

Ashland Industries Inc. in no way warrants Tires since these items are warranted separately by their respective manufacturer. Please call Ashland Industries Inc. to receive phone numbers of tire suppliers.

Ashland Industries Inc. in no way warrants wearable items such as cutting edges, front dolly wheel balls, socket halves.

Our obligation under this warranty shall be limited to repairing or replacing, free of charge to the original purchaser, any part that, in our judgement, shall show evidence of such defect, provided further that such part shall be returned within 30 days from the date of failure to Ashland Industries Inc. routed through the dealer and distributor from whom the purchase was made, transportation charges prepaid. Upon warranty approval proper credits will be reimbursed for transportation.

This warranty shall not be interpreted to render Ashland Industries Inc. liable for injury or damages of any kind or nature to person or property. This warranty does not extend to the loss revenue, extra labor cost associated with downtime, substitute machinery, rental or for any other reason.

Except as set forth above, Ashland Industries Inc. shall have no obligation or liability of any kind on account of any of its equipment and shall not be liable for special or consequential damages. Ashland Industries Inc. make no other warranty, expressed or implied, and, specifically, Ashland Industries Inc. disclaims any implied warrant or merchantability or fitness for a particular purpose. Some states or provinces do not permit limitations or exclusions of implied warranties or incidental or consequential damages, so the limitations or exclusion in this warranty may not apply.

This warranty is subject to any existing conditions of supply which may direct affect our ability to obtain materials or manufacture replacement parts.

Ashland Industries Inc. reserves the right to make improvements in design or changes in specifications at any time, without incurring any obligation to owners of units previously sold

No one is authorized to alter, modify or enlarge this warranty nor the exclusion, limitations and reservations.

Ashland Industries Inc.
Warranty Department