

## **GH 2500**

### How to Order Parts



## **HOW TO ORDER PARTS:**

### **IMPORTANT**

Parts must be ordered through your local authorized ASHLAND dealer.

Be sure to state MODEL and SERIAL NUMBER of your machine, PART NUMBER, DESCRIPTION and QUANTITY needed.



Unless this is done, we cannot provide prompt service or assure shipment of the correct parts.

Ashland Industries weldable replacement parts are available to rebuild, modify or update your scraper to current factory specifications.

# GH 2500

## Safety Guidelines



### SAFETY SIGNAL WORDS

Note the use of the signal words DANGER, WARNING and CAUTION with the safety messages. The appropriate signal word for each has been selected using the following guidelines:



**DANGER:** Indicates an imminently hazardous situation that, if not avoided, will result in death or serious injury.

This signal word is to be limited to the most extreme situations typically for machine components which, for functional purposes, cannot be guarded.



**WARNING:** Indicates a potentially hazardous situation that, if not avoided, could result in death or serious injury,

and includes hazards that are exposed when guards are removed. It may also be used to alert against unsafe practices.



**CAUTION:** Indicates a potentially hazardous situation that, if not avoided, may result in minor or moderate injury.

It may also be used to alert against unsafe practices.



### GENERAL SAFETY GUIDELINES

Safety of the operator is one of the main concerns in designing and developing a new piece of equipment. Designers and manufacturers build in as many safety features as possible. However, every year many accidents occur which could have been avoided by a few seconds of thought and a more careful approach to handling equipment. You, the operator, can avoid many accidents by observing the following precautions in this section. To avoid personal injury, study the following precautions and insist those working with you, or for you, follow them.

Replace any CAUTION, WARNING, DANGER or instruction safety decal that is not readable or is missing. Location of such decals is indicated in this booklet.

Do not attempt to operate this equipment under the influence of drugs or alcohol.

Review the safety instructions with all users annually.

This equipment is dangerous to children and persons unfamiliar with its operation. The operator should be a responsible adult familiar with farm machinery and trained in this equipment's operations. **Do not allow persons to operate or assemble this unit until they have read this manual and have developed a thorough understanding of the safety precautions and of how it works.**

To prevent injury or death, use a tractor equipped with a Roll Over Protective System (ROPS). Do not paint over, remove or deface any safety signs or warning decals on your equipment. Observe all safety signs and practice the instructions on them.

Never exceed the limits of a piece of machinery. If its ability to do a job, or to do so safely, is in question - **DON'T TRY IT.**

# **GH 2500**

## **Operator Instructions**

### **Requirements:**

Low flow hydraulics, with flat face couplers, (coupler not included)

Power Unit must meet or exceed 7,000 pound class of machine

70 + Horsepower Required

Must be a track unit or aftermarket tracks installed

Chain down loop on power unit frame for safety chain.

Universal Quick attachment plate.

All operators of this attachment must have read operators manual and fully Understand operation of the skid steer and this attachment.

Skid Steer must have a cab and a door that is capable of closing.

Cab of skid steer must have a impact resistant door.

### **Daily inspection of unit before operating:**

- Grease all zerks daily
- Check all hydraulic couplers and hydraulic hoses for leaks and condition.
- Check all hydraulic hoses to insure none are pinched or leaking
- Check tire pressure daily
- Check safety chain that is connected
- Check rollers on apron so it turns freely
- Check for excessive pin wear
- Check universal quick attachment plate and locks for cracks or excess wear
- Check cutting edges for excessive wear, cracks or loose plow bolts.
- Check cutting edges so they don't get wore down to the point that the frog is engaging the dirt (will cause premature failure of the frog).

### **Safety:**

**Never operate the machine unless you fully have read and understand the operation manual thoroughly.**

- Contact your local digger's hotline or underground utility locating service prior to starting the project.
- Before starting a project, check with your local authorities and have proper permissions and/or permits for the project, locate any property lines and or any buried items such as gas, phone, power lines etc.
- Visually inspect machine for worn parts or leaking hydraulics.
- Make sure safety chain is installed correctly and in good condition.
- Stay alert for hidden hazards or traffic.
- Do not carry passenger(s) on unit at any time.
- Never lift the Ground Hog 2500 off of the ground.
- Be aware of you environment and all hazards (people, telephone poles, guide wires, manholes etc.)
- Due to lowered visibility of operator, personnel on job site must stay at least 100 feet away from the working machine.
- When transporting skid steer and Ground Hog on the road, provide adequate warning lights to the operators of other vehicles.
- Never park unit on steep ground.
- Reduce speed when turning.
- When parking unit always lower the blade to the ground.

# GH 2500

## Operator Instructions

### Hooking skid steer to the Ground Hog 2500:

- Pull skid steer straight up to the Ground Hog 2500
- Visually inspect the Ground Hog 2500 mounting plate and universal quick attachment plates for dirt or debris ( if dirt or debris is present clean it out so proper hook up can be achieved)
- Unlock the attachment locks on universal quick attachment plate.
- Roll the universal quick attachment plate forward to engage the mounting plates.
- If you're unable to get the universal quick attachment plate to engage because it is too low or rolled under, hook up hydraulic hose and lower bowl to raise universal quick attachment plate.
- Roll the universal quick attachment plate back to engage the mounting plates.
- Secure locks on the universal quick attachment plate, do a visual inspection to make sure both pins are properly engaged with the mounting plate. If not fully engage unhook and inspect.
- Once connected lower loader arms fully to the bulk head to inspect ground clearance.
- If the bottom of the loader arms are too close to the ground while fully lowered, insert shims onto the bulk head to raise the loader arms up. The shims are usually available from the skid steer dealer (make sure not to put too many shims in the arms. Too many shims will limit the maximum depth of cut of the ground hog.)
- Secure the safety chain to the power unit by running it above or below the ground hog rockshaft onto the chain down loops on the power unit. Route the chain in a manner that it will not damage any hydraulic lines, attachment levers, shields or frame members.
- Make sure safety chain doesn't prohibit the operator's ability to enter or exit the skid steer.
- ***ALWAYS HOOK SAFETY CHAIN UP SO THE OPERATOR CAN NOT LIFT LOADER ARMS OFF THE BULKHEAD. IF OPERATED WITH LOADER ARMS UP DAMAGE TO LOADER ARMS MIGHT OCCUR***

### Operation of the Ground Hog 2500:

- **Always operate with loader arms fully lowered against bulk head while operating.**
- Before operating take time to get familiar with the operation of the skid steer controls and auxiliary hydraulics.
- While operating the groundhog use auxiliary hydraulics only.
- Leave tilt cylinders fully back (to prevent damage to the loader arms).
- When turning do not turn around in a tight circle. By making a wider turn, it will result in less wear on power unit and allow the operator to have better visibility of obstructions or personnel making for safer operation of the unit.

# GH 2500

## Operator Instructions

### Operation of the Ground Hog 2500 while **LOADING**:

- While skid steer is in motion lower cutting edge using the auxiliary control.
- Always leave the tilt cylinder fully "rolled" back (to prevent damage to the loader arms).
- If you cut with the tilt cylinder "rolled" forward, during the cut, the back of the floor of the bowl will drag during the cut causing premature wear of the floor.
- With the cutting edge engaging the ground, continue to lower cutting edge until scraper begins to consistently cut the dirt with the protruding center blade.
- To achieve a smoother cut, take longer shallower cuts while maintaining a constant ground speed.
- By keeping a consistent ground speed, the material that is loading into the bowl will constantly be turning in the bowl. With the material turning or "boiling" within the bowl, it allows you to develop bigger and quicker loads.
- During the cut, if the material is coming up onto the skid steer, using the auxiliary controls, slowly raise the cutting edge of the Ground Hog 2500 until the material quits flowing up on the skid steer and continue to load.
- If skid steer loses traction or loses ground speed slowly raise cutting edge until skid steer regains traction and/or ground speed.
- When scraper is full, raise cutting edge fully out of the ground and drive to the fill area.

**NOTE:** When loading, evaluate your job site. Things you should take into consideration, if possible load downhill, direction of travel of loaded scraper should be the shortest distance to unload site. Never run the scraper up onto stockpile higher than the operator.

### Operation of the Ground Hog while **UNLOADING**

- When unloading, evaluate your fill site. Things you should take into consideration, if possible unload on a level flat surface, direction of travel of loaded scraper should be the shortest distance to unload site.
- Never run the scraper up onto stockpile higher than the operator.
- With the skid steer moving at a safe speed, use the auxiliary hydraulics to raise the bowl of the scraper into the dump position.
- Allow the dirt to empty out of the bowl.
- Return the bowl to the carrying position.

### Operation when **TOP LOADING** the Ground Hog 2500:

- Make sure that you do not approach the loader or excavator on there blind side.
- Always come to a complete stop before starting to load the Ground Hog 2500.
- Always lower the Ground Hog 2500 bowl fully to the ground before loading (this will prevent damage to the lift cylinders and pins of the Ground Hog 2500).
- Never open door of skid steer or get out of the Skid Steer when the Ground Hog 2500 is being top-loaded.
- Once the Ground Hog 2500 is loaded, raise the bowl to a carrying position.
- Make sure the excavator or loader and all personnel are clear of the skid steer and groundhog and proceed to the fill area.

# **GH 2500**

## **Operator Instructions**

### **Operation of the Ground Hog on SIDE SLOPES:**

- ***Never under any circumstances operate the unit on a slope greater than a 4:1 (25%) slope.***
- ***Always consult operator's manual of skid steer for the limits of unit while operating on a side slope.***
- When operating on a side slope run the unit from the top to bottom (to prevent accidental overturn of skid steer and Ground Hog).
- When on a side slope always keep the unit as low to the ground as possible (to prevent accidental overturn of the machine).
- ***Whenever possible try not to run unit on side slope.***

### **LOADING the Ground Hog onto a TRAILER:**

- **Always transport the Ground Hog empty.**
- Remove any dirt or debris that may fall off during transport.
- Check for obstructions on the trailer bed (chains, blocks, etc.) if present, remove them from trailer before loading.
- Make sure the truck and trailer is rated to carry the gross weight of the skid steer and Ground Hog 2500 (if not sure consult the owners manual of both units).
- Make sure ramps are properly secured to trailer to prevent ramps from becoming un-attached while loading.
- You may find it necessary to undo the safety chain to provide higher clearance for the Ground Hog while loading (only lift groundhog high enough to clear the trailer as you are loading it).
- Make sure skid steer is in park or emergency brake is engaged and blade is lowered to the bed of the trailer.
- Make sure skid steer and ground hog is properly chained to trailer before transport.

### **Unloading from a trailer:**

- Visually inspect area (make sure trailer is on a flat level surface).
- Remove chains and binders.
- Make sure ramps are properly secured to trailer to prevent ramps from becoming un-attached while unloading.
- Check for obstructions on the trailer bed (chains, blocks, etc.) if present, remove them from trailer before loading.
- Have a spotter present to insure proper alignment of skid steer and groundhog to ramps.
- When the skid steer and Ground Hog 2500 is safely off the trailer, re-attach the safety chain.

## OPERATORS AND MAINTENANCE INSTRUCTIONS

This scraper is a durable piece of equipment and with proper care will yield many years of trouble free operation. The scraper requires a power source with TWO 4 way (double acting) hydraulic control valves.

The scraper should be greased at all points where grease fittings are provided. Connect hydraulic hoses to the tractor and retract lift cylinders to **REMOVE TRANSPORT LOCK PINS** (point A), then extend and retract all cylinders several times to force out any air from the hydraulic cylinders and lines. Check the oil levels in the tractor hydraulic system and add to maintain the proper level. Care should be used when adding oil or when disconnecting any oil line to keep all dirt out of the oil as dirt is a major factor in the failure of hydraulic components.

When the scraper is placed into operation, the operator will have to "feel out" the amount of depth of cut to obtain maximum loading efficiency. This is usually accomplished by taking a lesser and more uniform cut; however, some soil conditions such as loose sand may require a "pumping action" obtained by taking successive deep cuts and lifting out of cut as the tractor begins to lose power or traction.

1. After 10 hours work, all bolts should be checked and tightened if necessary.
2. Every 10 hours all grease fittings should be lubricated.
3. After 50 hours work, all bolts should be rechecked and tightened if necessary. Check wheel bearings and adjust if necessary.
4. After 300 hours work, clean and repack wheel bearings and replace, if necessary, cutting edges, worn pins, etc.

# WARNING

Because of the potential safety hazard to eyes from hydraulic leaks and/or flying debris, Ashland Industries feels that the **“USE OF PROTECTIVE EYEWEAR IS ABSOLUTELY MANDATORY”** for operators and others in the work area.

Due to the potential of danger of flying debris, it is **“ABSOLUTELY MANDATORY THAT IMPACT RESISTANT SHIELDING”** be provided on the power unit to protect the operator. The owner of the power unit is responsible for providing the operator protection devices on the power unit.



# GH 2500

## Safety Procedures

### Safety First

Accidents can be prevented by recognizing the causes or hazards before an accident occurs and doing something about them. Read this manual carefully and become familiar with the controls and proper use of the machine. Know how to stop the unit by disengagement of the controls. Be sure the operator knows how to exercise the mandatory shut down procedure.

Regardless of the care used in the design and construction of this equipment, there are some areas that cannot be safeguarded without interfering with accessibility and efficient operation.

**TAKE NOTE! THIS SAFETY ALERT SYMBOL FOUND THROUGHOUT THIS MANUAL IS USED TO CALL YOUR ATTENTION TO INSTRUCTIONS INVOLVING YOUR PERSONAL SAFETY AND THE SAFETY OF OTHERS. FAILURE TO FOLLOW THESE INSTRUCTIONS CAN RESULT IN INJURY OR DEATH.**

The following safety information is a general overview of precautions that should be adhered to:

1. Read this manual carefully. Become thoroughly familiar with the controls and proper use of this machine. Insure that all operators know how to stop the unit by disengagement of the controls using the "Mandatory Shut-Down Procedure" as per your power units operators manual.
2. Remember, it is the owner's responsibility for communicating all information on the safe and proper use and maintenance of this machine.
3. Never allow children to operate equipment. Allow Adults to operate equipment only after receiving the proper instructions. Keep the area of operation clear of all unauthorized persons.

### Safety Procedures

#### CAUTION:

- Keep children, spectators and other workers off and away from the machine while it is operating or engine is running. Do not carry passengers.
- Read and observe all warning decals on the machine and power unit before attempting to operate the scraper. So not attempt to operate this machine unless all factory devices and decals are in place. Keep all safety decals free of dirt and grime. Keep all guards, shields and decals in place.
- The operator must not use drugs or alcoholic beverages which would impair his/her coordination while working. An operator who is taking prescription drugs must get medical advice to determine is he can safely operate a machine.
- Stay alert for hidden hazards or traffic.
- Never operate scraper without good light and visibility.
- Make sure all controls, (levers, pedals and switches), are in neutral position before starting the loader engine.



#### WARNING:

- Keep all guards, shields & decals in place.
- Before working under any hydraulically controlled implement, be certain it is securely blocked!
- Because of the potential safety hazard to eyes from hydraulic leaks and/or flying debris, **"USE OF PROTECTIVE EYEWEAR IS ABSOLUTELY MANDATORY"** for operator and others in work area.
- Always use an approved roll bar and seatbelt for safe operation, overturning a loader without a rollbar and seatbelt can result in injury or death.

# GH 2500

## Safety Procedures

- The use of handholds and step plates when getting on and off the loader to prevent falls. Keep steps and platform cleared of mud and debris.
- Operate the scraper only from the operator's seat.
- Keep your feet on the pedals, (floor plates) seat belt fastened snugly and seat bar lowered, when operating the scraper.

### Operation Safety:

- Because this machine will be operated in a potentially hazardous environment it is **ABSOLUTELY MANDATORY** that you read and follow these safety precautions.



### **WARNING:**

- Due to the possible danger of flying debris within the load, it is **ABSOLUTELY MANDATORY** that **IMPACT RESISTANT SHIELDING** be provided on the power unit to protect the operator. The owner is responsible for providing the operator protection devices on the power unit.
- Stay alert for hidden hazards or traffic, do not carry passengers.
- Never operate the scraper without good light or visibility.
- When transporting the scraper on the road during the day or night, provide adequate warning to operators and vehicles.
- Never park on a steep incline.
- Do leave equipment in raised position.
- **DO NOT** allow ANY people or animals within 100 feet of the work area while operating this machine.

- Thoroughly clear the work area of ALL foreign objects such as: fence posts, rebar, and other long objects that can project forward through the cab while loading.
- When high pressure fluid escapes, it can be almost invisible, yet have enough pressure to penetrate the skin and enter the blood stream. Never attempt to use hands to search for suspected oil leaks. If injured by escaping fluid, consult a doctor at once! Serious reaction or infection can occur if proper medical treatment is not obtained immediately.
- Never operate the scraper without guards, shields, plates or other safety devices in place. Shields are for your protection; please keep all shields in place.



### **Danger:**

- Never get off the Skid Steer while it is in motion.

# **GH 2500**

## Parts diagram

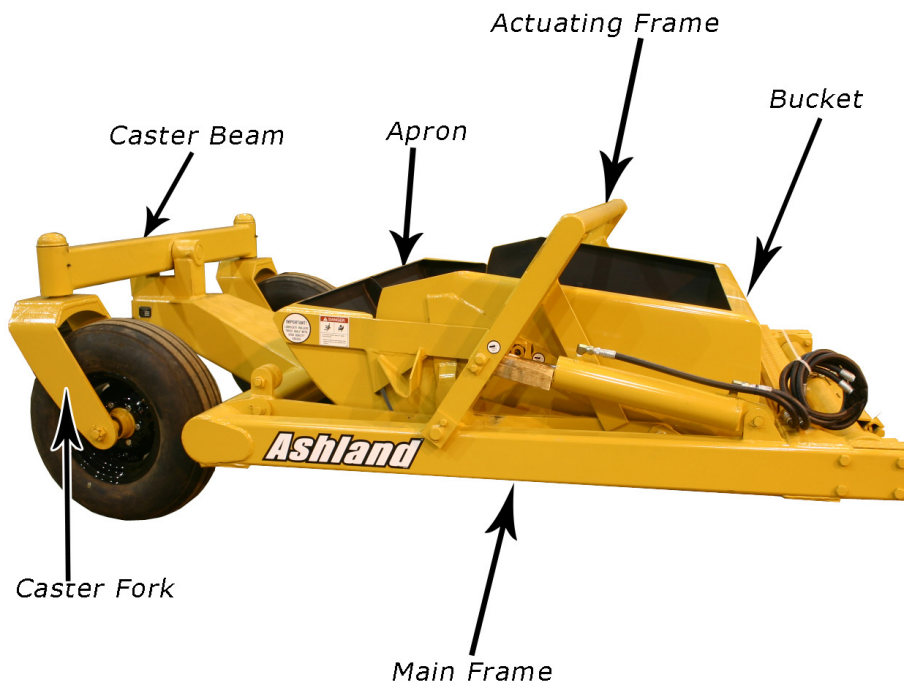

GH\_diagram1-ILL

# GH 2500

## Actuating Frame Assembly

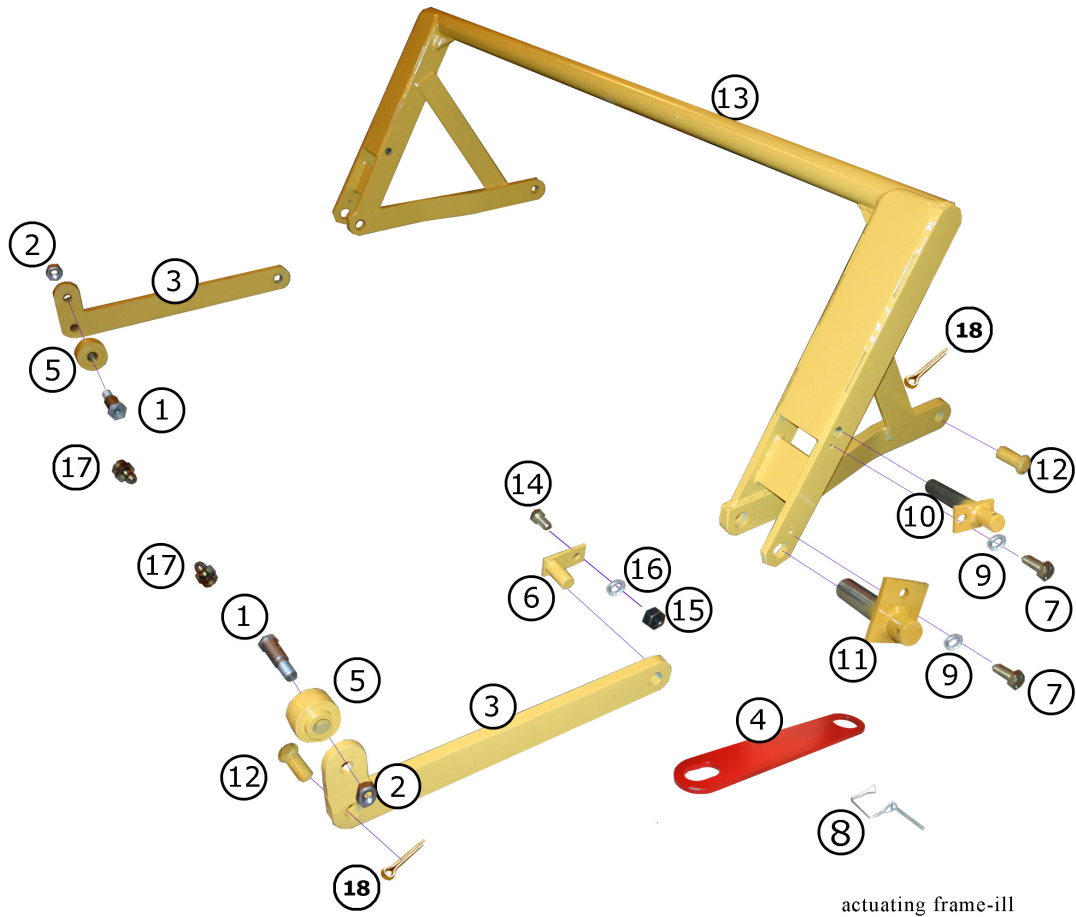

Key Number	Part Number	Description	Qty Required
1	A30003	Pin: 1-1/4 to NF 1" x 2-1/2" Shoulder, includes nut AFN 00001 & Zerk 14505	2
10	A3318A	Pin	2
11	A2502A	Pin	2
12	A3310	Pin	2
13	A2506	Actuating frame	1
14	7115	HHCS: 5/8 NC x 1-1/4	2
15	7530	Nut: 5/8	2
16	A110	5/8" LW	2
17	14505	Grease Zerk st 1/8" npt	2
18	8602	1/4 x 2 cotter pin	4
2	AFN-00001	Nut: Lock 1" NF	2
3	A012165	Act. Arm: Right & Left	2
4	A123475	Transport Lock	2
5	A30002	Roller: Actuating Arm - Cast	2
6	A4505	Pin	2
7	7000	HHCS: 1/2" NC x 1"	4
8	A125006	Snap Pin	2
9	8100	1/2" Lock Washer	4

# GH 2500

## Hydraulic Line Tubing & Plumbing

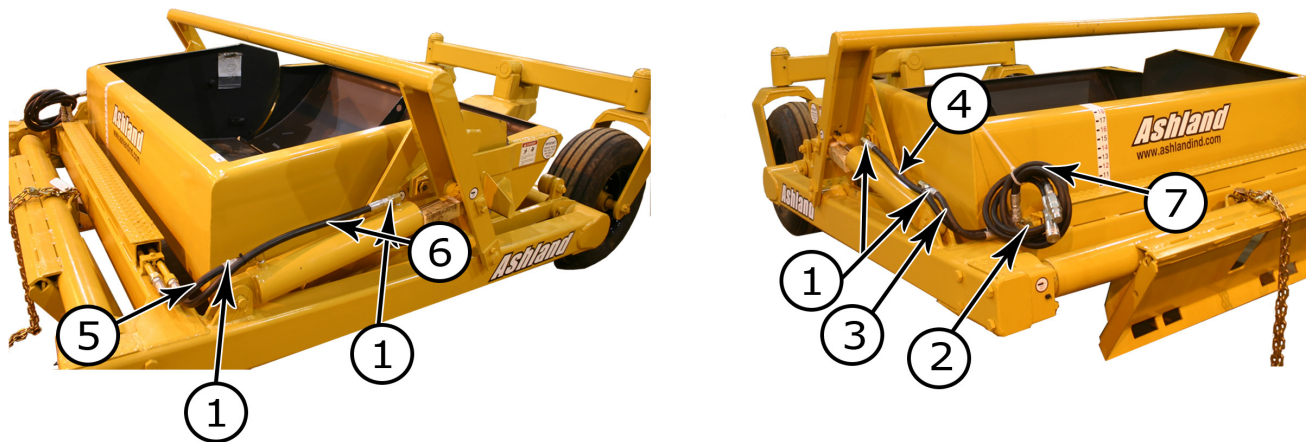

GH\_hydtub-ILL

Key Number	Part Number	Description	Qty Required
1	A45H07	Adapter: 90 Swiv. 1/2 MP x 1/2 FP S.N.'s 21584 and below	4
1	AHA-0023	Adapter: 90 Swiv. moro ? FP ORB S.N.'s 21585 and above	4
2	AHA-00049	Adapter: T 3/4 MJ x 3/4 MJ x 3/4 MJ	2
3	A125218	Hose Ass'y.: Left Cyl. - Rear	1
4	A125219	Hose Ass'y.: Left Cyl. - Front	1
5	A125218	Hose Ass'y.: Right Cyl. - Rear	1
6	A125219	Hose Ass'y.: Right Cyl. - Front	1
7	A125220	Hose Ass'y.: Connecting	2

# GH 2500

## Hydraulic Cylinder

### HYDRAULIC CYLINDER 3-1/2" BORE X 16" STROKE (STANDARD)

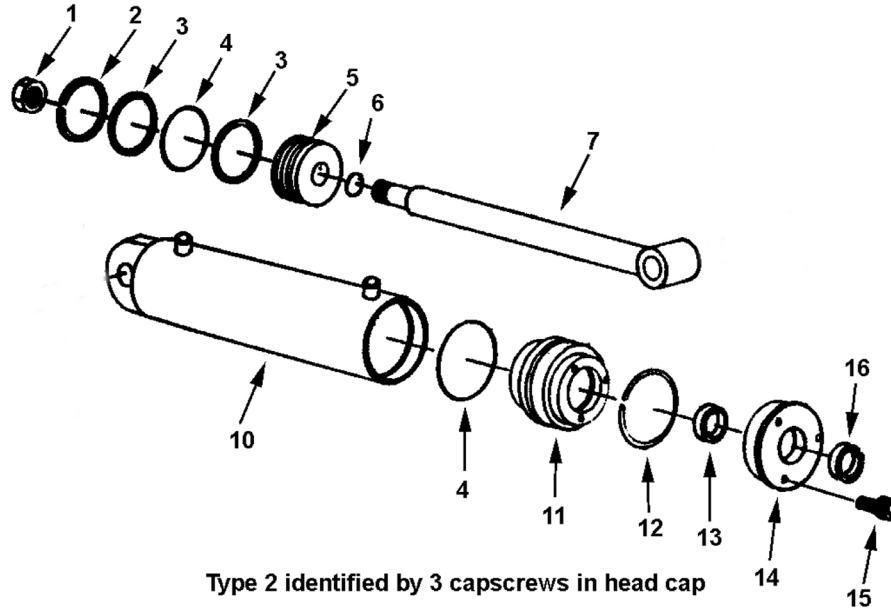

A-3516H1-ILL

Qty.	Part Number	Qty.	Part Number
1	A22H06	1	A22H15B
2	A22H07	1	A22H10A
2	A22H08	1	A22H17

Key Number	Part Number	Description	Qty Required
1	A22H05	Piston nut, 3/4" NF	1
12	A22H14	Retainer Ring	1
13	A22H15B	ucup	1
14	A22H16	Head Cap	1
15	A22H18	Gapscrew, 1/4" x 1"	3
16	A22H17	Wiper Seal, 1-1/2" ID	1
17	A22H19B	Packaging Kit Containing: *See Note*	
17	14505	Grease Zerk	1
2	A22H06	Cast iron ring, 3-1/2" OD	1
3	A22H07	Back up washer, 3-1/4" OD	2
4	A22H08	O-ring seal, 3-1/2" x 3/16"	2
5	A22H09	Piston, 3-1/2"	1
6	A22H10	Piston Gasket, 3/4" ID	1
7	A22H11	Shaft, 1-1/2" diameter	1
10	A22H12	Barrel Assembly	1
11	A22H13	Head Gland, 3 1/2"	1

# GH 2500

## Main Frame

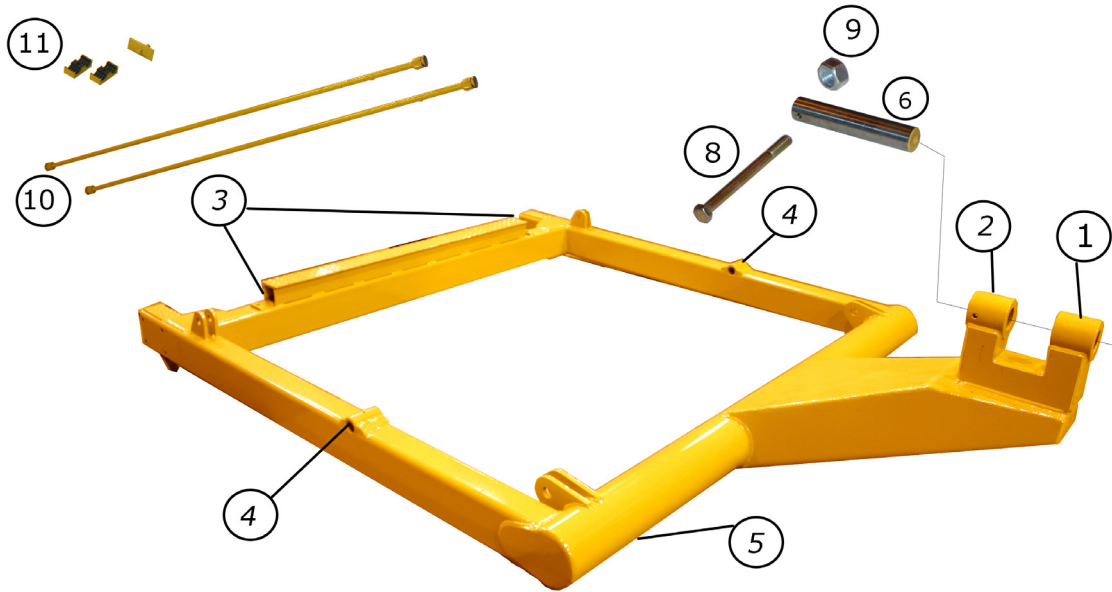

GH\_A123466-III

Key Number	Part Number	Description	Qty Required
1	A123465-21	Bushing: Main Pivot Ground Hog (weld-in)	1
11	AHL-00002	Tube Clamp Ass'y	2
2	A123465-21A	Bushing: Main Pivot w/Hole Ground Hog (weld-in)	1
3	AHL-00002	Clamp: Hyd. Line - 2 Tube Ass'y	2
4	A123465-5	Bushing: Apron/Act. Frame Pivot (Weld in)	2
5	A123466	Main Frame	1
6	A123469-05	Pin: Castor Beam Pivot	1
8	AFB-00089	HHCS: 1/2 NC x 5-1/2" Gr. 8	1
9	7500	Nut: 1/2" NC Gr. 5 zinc	1
10	A12-5039	Tube Ass'y.	2

# **GH 2500**

## **Wheel & Hub Assembly**

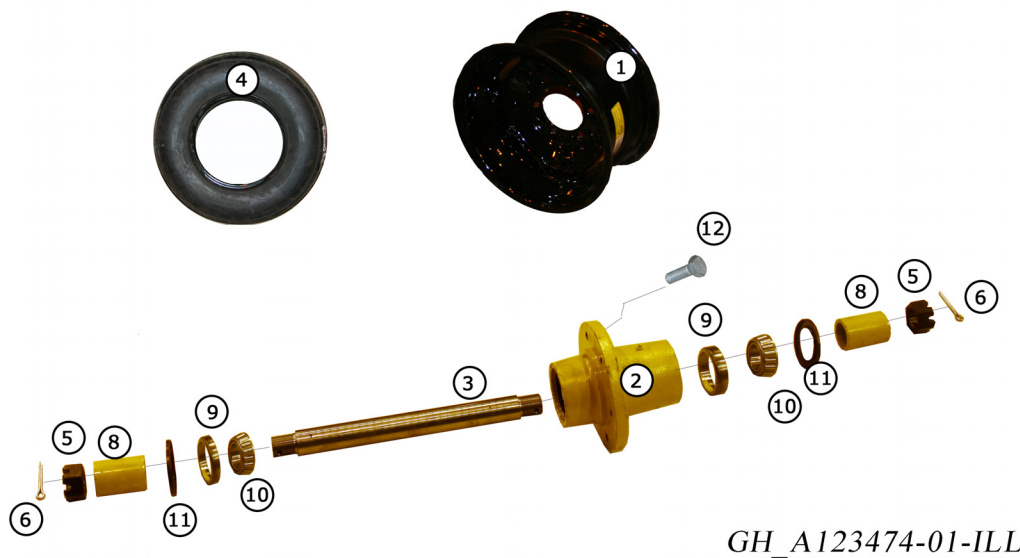

GH\_A123474-01-ILL

<b>Key Number</b>	<b>Part Number</b>	<b>Description</b>	<b>Qty Required</b>
1	A3319A	Wheel: 15 x 8" DC 6 Hole	1
11	A125197-03	Seal	2
12	A2236	Wheel Bolt	6
2	A125197	Hub	1
3	A123474-01	Axle: Front Caster Wheel	1
4	ATI-00002	Tire: 11L - 15 8 Ply	1
5	AFN-00010	Nut: Slotted 1-1/4" NF	2
6	8602	Cotter Pin 1/4 x 2	2
8	A123474-02	Spacer	2
9	A125197-01	Bearing: Cup	2
10	A125197-02	Bearing: Cone	2



# GH 2500

## Rock Shaft

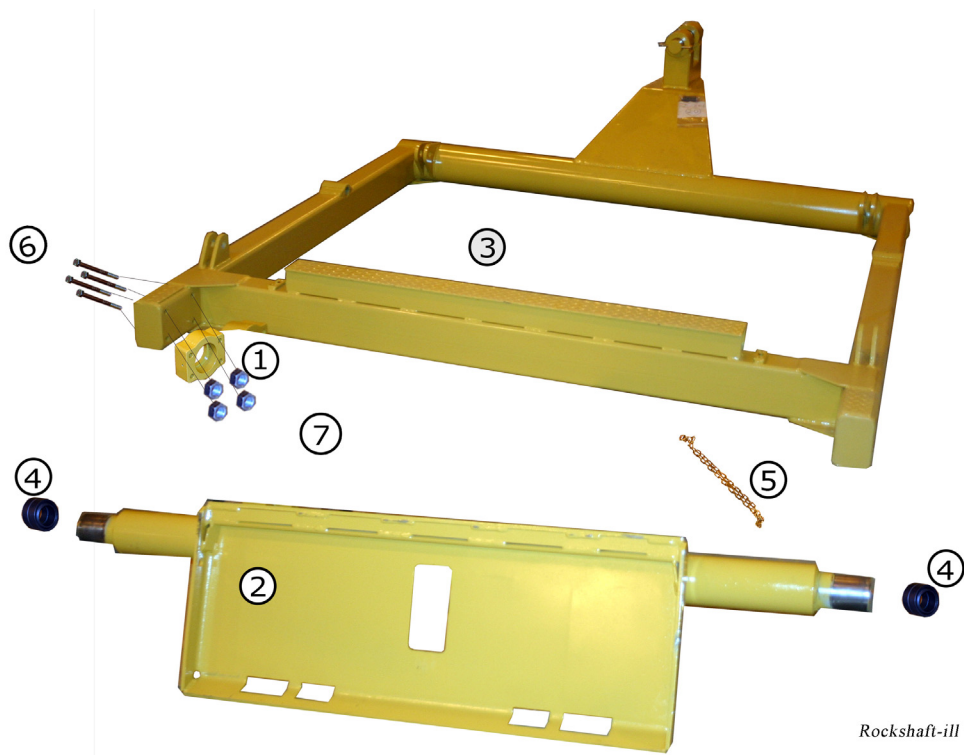

Key Number	Part Number	Description	Qty Required
1	A123471-03	Ball Bushing Mount	1/side (2 total)
2	A123472	Rock Shaft Assembly	1
3	A123466	Frame	1
4	A125212	Ball Bushing	1/side (2 total)
5	A125215	Safety Chain	1
6	AFB-00111	HHCS: 3/4 NC x 8" Gr. 8 Zinc	4/side (8 total)
7	750439	Nut: Lock 3/4" NC Gr 8 Zinc	4/side (8 total)

# GH 2500

## Oscillating Beam

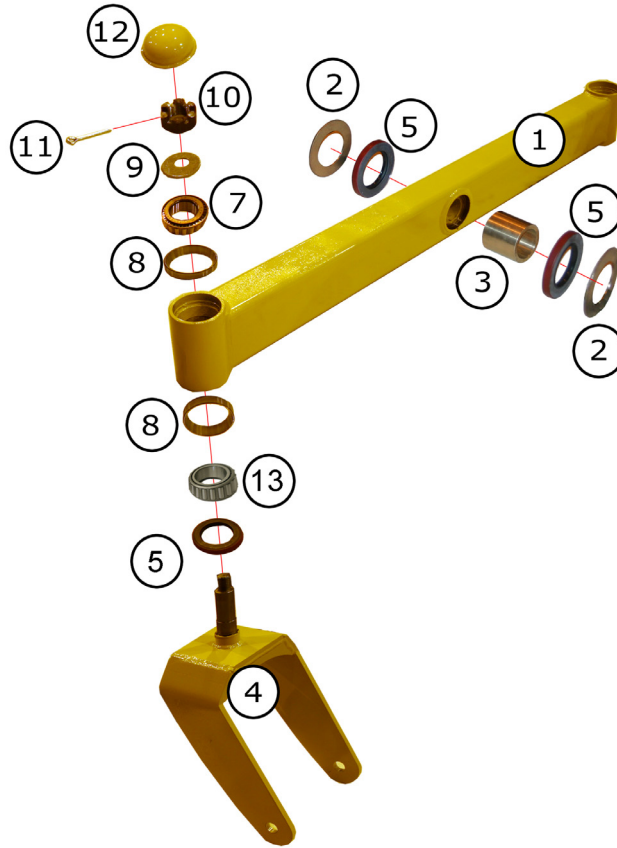

*GH\_A123470-ill*

Key Number	Part Number	Description	Qty Required
1	A123470	Oscillating Beam	1
11	8602	Cotter Pin	1
12	A8026	Cap: Hub Mod's 80 & 900	1
13	A125216	Cone Bottom	
2	A125209	Bushing: Thrust Ground Hog	2
3	A125200	Bushing: Pivot Ground Hog	1
4	A123468	Caster Fork Ground Hog	1
5	A4512	Seal: Grease 3-7/8"OD x 2-1/2" ID	3
7	A125205	Bearing: Cone top	1
8	A4514	Bearing: Cup	2
9	A8027	Spindle Washer	1
10	AFN-00010	Nut: Slotted 1-1/4" NF	1

# GH 2500

## Bucket & Apron

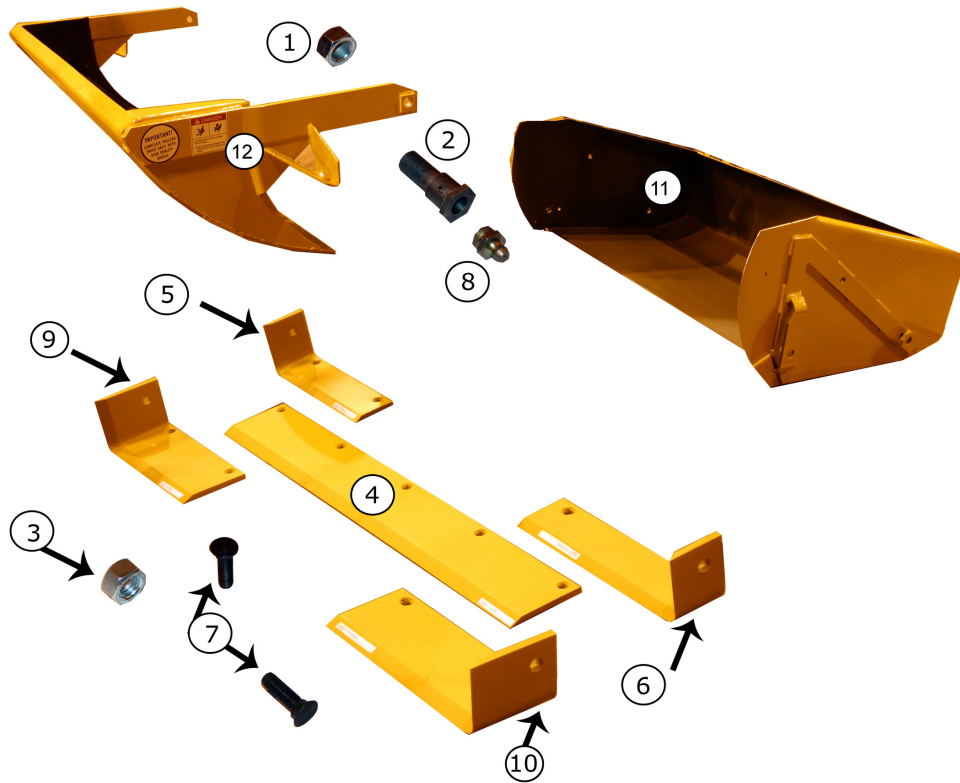

GH\_A2504-ill

Key Number	Part Number	Description	Qty Required
1	AFN-00001	Nut: Lock 1" NF	1/per side
10	A2222	Opt 6" Left	1
11	A2504	Bowl	1
12	A3317	Apron	1
2	A30020	Pin: 1-1/4" to 1" NFX 1-1/8" L Shoul. includes (1) AFN-00001	1/per side
3	7500	Nut: 1/2" NC Gr. 5 Zinc	11/per set of blades
4	A30021	Blade: Center 1/2 x 6 x 42" (25, 35)	1
5	A2221	Blade: Left 1/2 x 4" (25, 35)	1
6	A2224	Blade: Right 1/2 x 4" (25, 35)	1
7	PB5P-NC-050-0175	Bolt: Plow 1/2 NC x 1-3/4" Gr. 8	11 per set
8	14505	Grease Zerk	1/ per side
9	A2225	Opt 6" Right	1

# GH 2500

## Decals

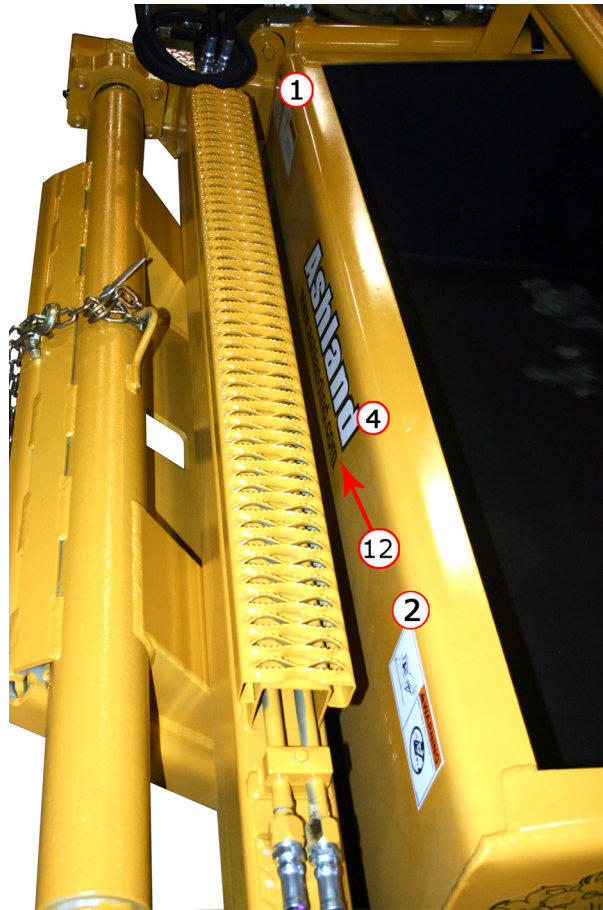

GH\_decals1-III

Key Number	Part Number	Description	Qty Required
1	750464	Decal: "High Pressure Fluid Hazard"	2
10	ADS-00019	Twice Daily	8
11	ADS-00020	Lubricate Rollers	2
12	ADS-00020	www.ashlandind.com	1
2	ADS-00011	Decal: "Pinch Point"	2
3	ADS-00029	Decal: patent pending	1
4	ADS-00002	Decal: Small Ashland Logo ( 4 x 21.55")	4
5	ADS-00030	Decal: Turning	3
6	ADS-00031	Decal: Loader Arms	1
7	ADS-00034	Ground Hog decal Long	1
8	ADS-00033	Ground Hog decal Large	2
9	ADS-00032	Ground Hog decal Small	1

## **Limited Warranty Statement**

Ashland Industries Inc. warrants each new product to be free from defects in material and workmanship. This warranty is applicable only for the normal service life expectancy of the product or components, not to exceed **six consecutive months** from the date of delivery of the new Ashland Industries product to the purchaser, or the date the product is first put into service via a rental agreement or other means, whichever occurs first.

The major components of swivel hitches used on Industrial series scrapers are warranted for three consecutive months from the date of delivery of the new Ashland Industries product to the purchaser, or the date the product is first put into service via a rental agreement or other means, whichever occurs first, except those components described below.

Genuine Ashland Industries Inc. replacement parts and components will be warranted for 30 days from date of purchase, or the remainder of the original equipment warranty period, whichever is longer.

Under no circumstances will it cover any merchandise or components thereof, which in the opinion of the company, has been subjected to misuse, unauthorized modification, alterations, an accident or if repairs have been made with parts other than those obtained through Ashland Industries Inc.

Ashland Industries Inc. in no way warrants Tires since their respective manufacturer warrants these items separately. Please call Ashland Industries Inc. to receive phone numbers of tire suppliers.

Ashland Industries Inc. in no way warrants wearable items such as cutting edges, front dolly wheel balls, socket halves, rollers, bushings, yoke hitch pins, hitch bushings, etc..

Our obligation under this warranty shall be limited to repairing or replacing, free of charge to the original purchaser, any part that, in our judgement, shall show evidence of such defect, provided further that such part shall be returned within 30 days from the date of failure to Ashland Industries Inc. routed through the dealer and distributor from whom the purchase was made, transportation charges prepaid. Upon warranty approval proper credits will be reimbursed for transportation.

This warranty shall not be interpreted to render Ashland Industries Inc. liable for injury or damages of any kind or nature to person or property. This warranty does not extend to the loss revenue, extra labor cost associated with downtime, substitute machinery, rental or for any other reason.

Except as set forth above, Ashland Industries Inc. shall have no obligation or liability of any kind on account of any of its equipment and shall not be liable for special or consequential damages. Ashland Industries Inc. make no other warranty, expressed or implied, and, specifically, Ashland Industries Inc. disclaims any implied warrant or merchantability or fitness for a particular purpose. Some states or provinces do not permit limitations or exclusions of implied warranties or incidental or consequential damages, so the limitations or exclusion in this warranty may not apply.

This warranty is subject to any existing conditions of supply which may direct affect our ability to obtain materials or manufacture replacement parts.

Ashland Industries Inc. reserves the right to make improvements in design or changes in specifications at any time, without incurring any obligation to owners of units previously sold

No one is authorized to alter, Modify or enlarge this warranty nor the exclusion, limitations and reservations.

Ashland Industries Inc.  
Warranty Department