

Ashland

EARTHMOVERS

CS18-HD

PARTS MANUAL

Version 03-09



Ashland Industries Inc.
1115 Rail Drive
P.O. Box 717
Ashland, WI. 54806
877-634-4622 Toll Free - phone
715-682-4622 phone
715-682-9717 fax
www.ashlandind.com

MEMBER



CONSTRUCTION INDUSTRY
MANUFACTURERS ASSOCIATION





HOW TO ORDER PARTS:

IMPORTANT

Parts must be ordered through your local authorized ASHLAND dealer.

Be sure to state MODEL and SERIAL NUMBER of your machine, PART NUMBER, DESCRIPTION and QUANTITY needed.



Unless this is done, we cannot provide prompt service or assure shipment of the correct parts.

Ashland Industries weldable replacement parts are available to rebuild, modify or update your scraper to current factory specifications.

Index

- Page 2-5. Safety Guidelines
- Page 6-12. Operator and Maintenance Instructions
- Page 13. Assembly-Illustration
- Page 14. Hitch-Illustration and parts
- Page 15. Front Section Frame-Illustration and parts
- Page 16. Lift Cylinder 5 ½ X 20 – Illustration and parts
- Page 17. Apron Assembly – Illustration and parts
- Page 18. Apron Cylinder – Illustration and parts
- Page 19. Bowl and Frame Assembly – Illustration and parts
- Page 20. Dump Cylinder – Illustration and parts
- Page 21. Wheel Assembly – Illustration and parts
- Page 22. Wheel and Hub – Illustration and parts
- Page 23. Pins – Illustration
- Page 24. Hydraulic Valve – Identification, Illustration, Parts, and Adjustment
- Page 25. Hydraulic Schematic
- Page 26-27. Maintenance Checklist and Lubrication
- Page 28. Troubleshooting
- Page 29. Warranty Statement

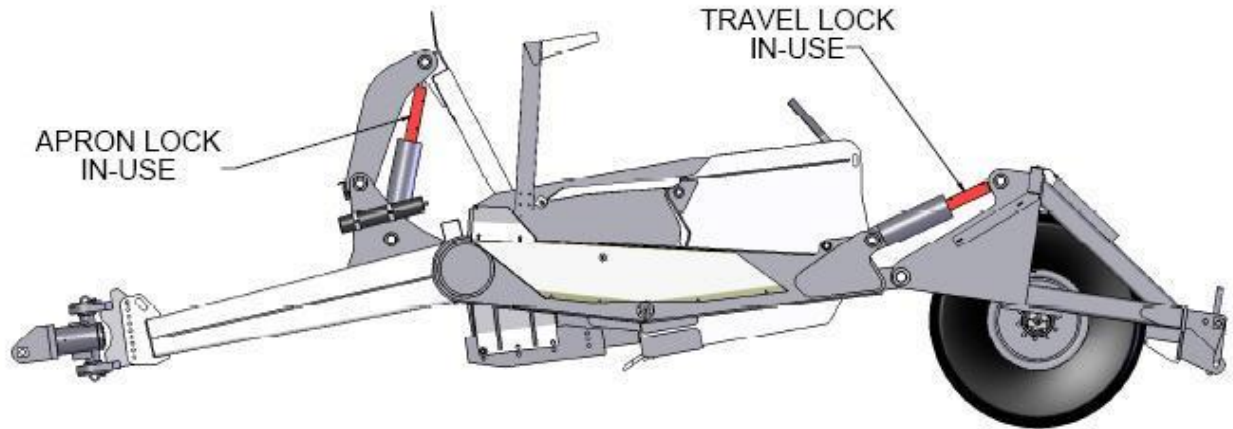

Figure 1

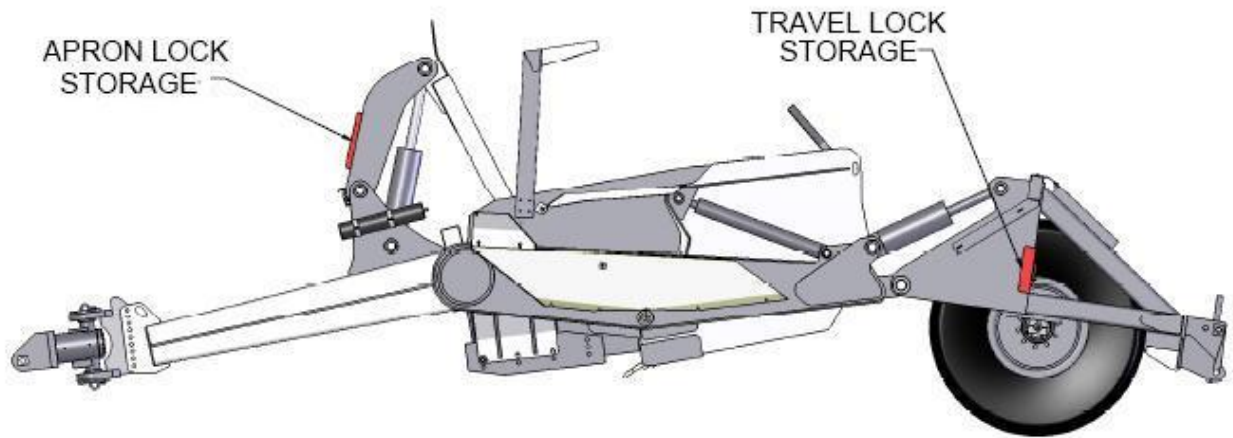

Figure 2

IMPORTANT

Please locate red Transport Links and remove prior to operation. Retract Lift Cylinder Circuit, Remove Safety Snap Pin, Remove link and replace into storage position as shown in figure 2.

Reinstall Safety Snap Pins.

**SAFETY SIGNAL WORDS**

Note the use of the signal words **DANGER**, **WARNING** and **CAUTION** with the safety messages. The appropriate signal word for each has been selected using the following guidelines:



DANGER: Indicates an imminently hazardous situation that, if not avoided, will result in death or serious injury.

This signal word is to be limited to the most extreme situations typically for machine components which, for functional purposes, cannot be guarded.



WARNING: Indicates a potentially hazardous situation that, if not avoided, could result in death or serious injury, and includes hazards that are exposed when guards are removed. It may also be used to alert against unsafe practices.



CAUTION: Indicates a potentially hazardous situation that, if not avoided, may result in minor or moderate injury. It may also be used to alert against unsafe practices.

**GENERAL SAFETY GUIDELINES**

Safety of the operator is one of the main concerns in designing and developing a new piece of equipment. Designers and manufacturers build in as many safety features as possible. However, every year many accidents occur which could have been avoided by a few seconds of thought and a more careful approach to handling equipment. You, the operator, can avoid many accidents by observing the following precautions in this section. To avoid personal injury, study the following precautions and insist those working with you, or for you, follow them.

Replace any **CAUTION**, **WARNING**, **DANGER** or instruction safety decal that is not readable or is missing. Location of such decals is indicated in this booklet.

Do not attempt to operate this equipment under the influence of drugs or alcohol.

Review the safety instructions with all users annually.

This equipment is dangerous to children and persons unfamiliar with its operation. The operator should be a responsible adult familiar with farm machinery and trained in this equipment's operations. **Do not allow persons to operate or assemble this unit until they have read this manual and have developed a thorough understanding of the safety precautions and of how it works.**

To prevent injury or death, use a tractor equipped with a Roll Over Protective System (ROPS). Do not paint over, remove or deface any safety signs or warning decals on your equipment. Observe all safety signs and practice the instructions on them.

Never exceed the limits of a piece of machinery. If its ability to do a job, or to do so safely, is in question - **DON'T TRY IT.**

OPERATORS AND MAINTENANCE INSTRUCTIONS

This scraper is a durable piece of equipment and with proper care will yield many years of trouble free operation. The life of your scraper can be severely shortened by poor maintenance. Follow consistent maintenance practices and use good quality grease and hydraulic oil (compatible with the power unit's hydraulic system) to insure the longest, most productive use from your equipment.



Before starting the job, make sure Diggers Hot Line has been contacted and all underground utilities have been properly located (electric, phone and pipelines). Have a clear understanding of all local, OSHA and MSHA rules that apply to the job. Beware of your environment and keep others a safe distance from the machine while familiarizing yourself with the machine's controls. The scraper requires a power source with TWO 4 way (double acting) hydraulic control valves.

The scraper should be greased at all points where grease fittings are provided. Connect hydraulic hoses to the tractor and retract lift cylinders to **REMOVE TRANSPORT LOCK PINS** (point A), then extend and retract all cylinders several times to force out any air from the hydraulic cylinders and lines. Check the oil levels in the tractor hydraulic system and add to maintain the proper level. Care should be used when adding oil or when disconnecting any oil line to keep all dirt out of the oil as dirt is a major factor in the failure of hydraulic components. Each time the scraper is holed to a power unit, the sequencing valve needs to be checked for proper timing. This will insure optimum performance from the scraper.

When the scraper is placed into operation, the operator will have to "feel out" the amount of depth of cut to obtain maximum loading efficiency. This is usually accomplished by taking a lesser and more uniform cut; however, some soil conditions such as loose sand may require a "pumping action" obtained by taking successive deep cuts and lifting out of cut as the tractor begins to lose power or traction. The operation of the scraper will vary depending upon soil type, moisture content, power-unit and jobsite. Results will vary.

1. After 10 hours work, all bolts should be checked and tightened if necessary.
2. Every 10 hours all grease fittings should be lubricated.
3. After 50 hours work, all bolts should be rechecked and tightened if necessary. Check wheel bearings and adjust if necessary.
4. After 300 hours work, clean and repack wheel bearings and replace, if necessary, cutting edges, worn pins, etc.

OPERATORS AND MAINTENANCE INSTRUCTIONS**SCRAPER DAMAGE CAN OCCUR IF:**

1. The scraper is running over the haul road with the bowl fully raised.
2. A power unit that is above the horsepower rating is pulling the scraper.
3. The scraper is being used to level haul roads with the apron closed.
4. The scraper is being top loaded with the bowl is a raised position.
5. The scraper is being used to load rock.

These types of damage are not covered by warranty. Warranty only covers defects in material or workmanship and not abuse because of improper use.

KNOW THE JOB:

1. Know the weight of the material to be moved.
2. Lay the job out to take advantage of grades when loading, if possible.
3. Keep hauls as short as possible.
4. Keep haul roads smooth.
5. If more than one unit is on the job, make sure the haul roads are one way and that the operators understand the direction.
6. Brief the operators as to what the job consists of so there is not misunderstanding.
7. Know the moisture content in the material to be moved.
8. Will water be needed for proper compaction?
9. Will drainage be a problem?
10. How many units will be needed to efficiently complete the job?

TRANSPORT SCRAPER SAFELY:

1. Always empty scraper.
2. Clean all material from exterior of scraper.
3. Make sure all road rules are followed.
4. Use proper lighting and flagging.
5. Lower scraper bowls to provide just enough clearance over obstacles.
6. Transport at a safe speed to avoid roll over.
7. Reduce speed on curves and when going down hill.

OPERATORS AND MAINTENANCE INSTRUCTIONS

APRON OPENING GUIDELINES:

You will need to determine the ideal opening for your soil condition. It is important to have the apron opened prior to loading. To receive the highest production possible, it is important to know the general characteristics of the material that you will be loading. In heavier soils like clay or gumbo, the soil will slab up and remain together after being cut by the blades. In lighter soils, like sand or dry loose top soil, the material will pile up or push after being cut by the blade. Use the suggestions listed below:

Topsoil with heavy vegetation (12" to 24" opening):

When cutting undisturbed soils, you will need to open the apron high enough to allow debris to easily enter the scraper bowl. If the apron is opened too high, the rolling up sod will fall out past the apron and hinder the incoming material. If the apron is not adjusted quick enough, the material will bunch or push ahead of the machine. If this happens, you should close the apron and pull out the cut quickly. If you wait too long, you may develop too large a pile to clear the scraper while rising out of the cut. This can cause the power unit to lose traction and possibly cause you to get stuck.

Clay or loamy material (6" to 12" opening):

To cut clay or loam soils, lower the apron to approximately 6" to 12" between the blades and the bottom of the apron. When you first lower the bowl, you'll see the material being cut by the blades and entering the bowl. As you continue to move forward, small clumps will fall past the apron and develop a small pile ahead of the apron. By limiting this apron opening, the small pile will "blade off" any loose material ahead of the machine. Adjustments should be made if large objects such as rocks or deep gouges are within the cut.

Sand or loose top soil (15" to 30" opening):

Loading sand or loose top soil is the most difficult type of soil to load. In combination with the larger apron opening, you'll want to operate at a faster ground speed. By traveling faster and lowering the blade deeper than normal, it forces the material into the scraper bowl.

We encourage you to experiment with different apron openings to determine the best condition for your jobsite.



The Apron is designed to capture material inside of the scraper bowl and should not be used as a large blade. Obstructions like large rocks or dense piles may cause the apron to bend inward after prolonged exposure to these conditions.

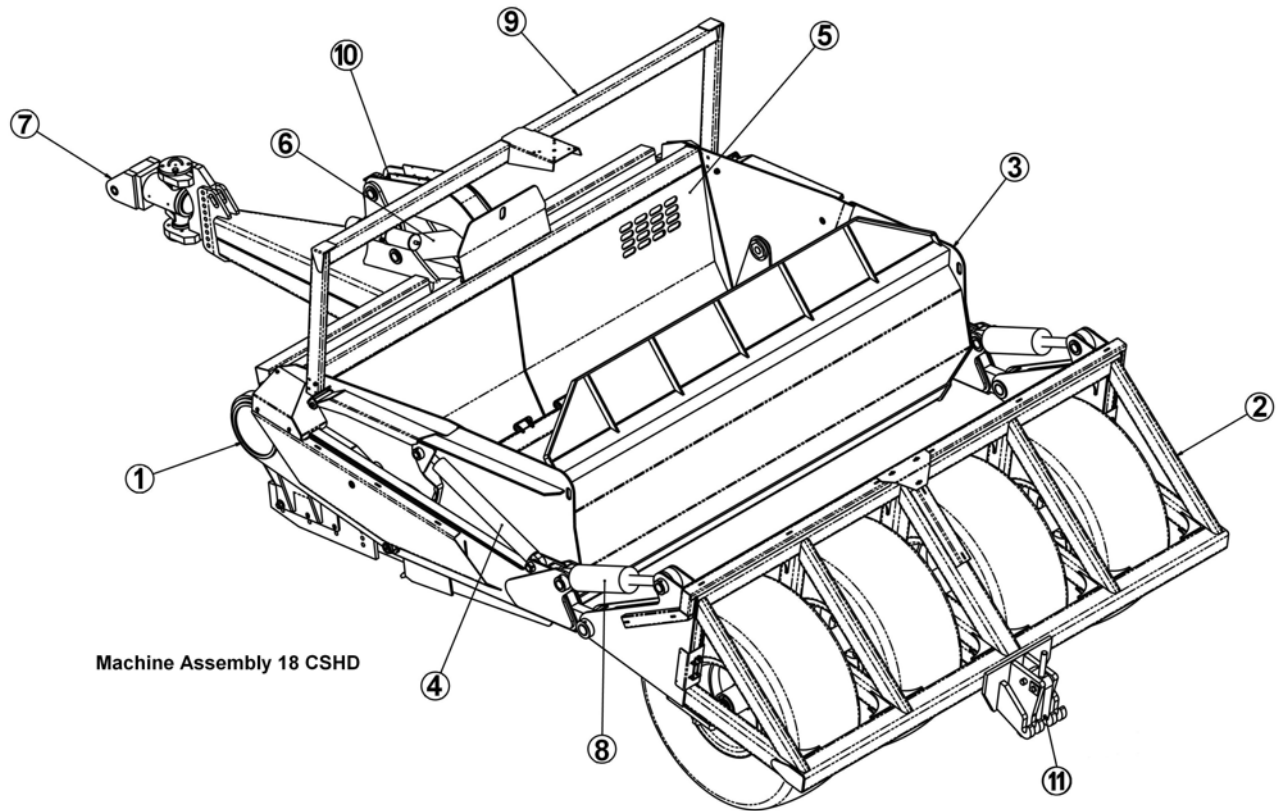

Machine Assembly 18 CSHD

Key Number	Part Number	Description
1	700001	Front Section
2	700002	Rear Section
3	700004	Bowl
4	A125160	Bowl Dump Cylinder
5	700003	Apron
6	A125158	Apron Lift Cylinder
7	A125224	Super Swivel Hitch
8	A125159	Main Lift Cylinder
9	700005	Laser Mount (Optional)
10	600031	Apron Lift Arm
11	600009	Locking Lug

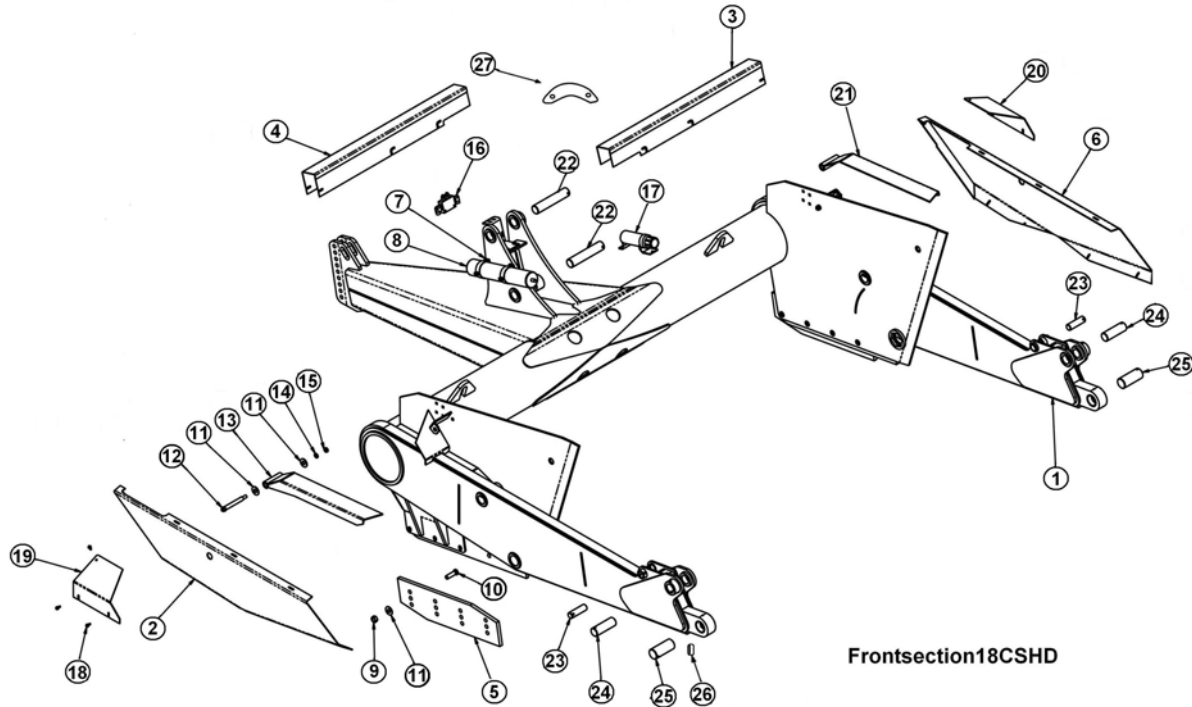

Key Number	Part Number	Description
1	600033	Frame-Front Section
2	600003	Arm Guard LH
3	600008	Front Pipe Guard RH
4	600007	Front Pipe Guard LH
5	500164	Bank Edge
6	600004	Arm Guard RH
7	A125009	Accumulator Bracket
8	A125051	Accumulator
9	AFN-00012	1" NC Heavy Hex Nut
10	PB1P-NC-100-0375	1" Plow Bolt x 3 3/4" Lg
11	AFW-00001	1" Flat Washer
12	600002	Top Shield Pin
13	600005	Top Pivot Shield LH
14	AFW-00002	3/4" NC Lock Washer
15	7680	3/4" NC Hex Jam Nut
16	A125211	Valve
17	A125180	Manual Canister
18	AFB-00094	3/8"NC Flanged Bolt
19	500395	Guard Corner LH
20	500394	Guard Corner RH
21	600006	Top Pivot Shield RH
22	500332	Pin-Apron Lift Cylinder
23	500335	Pin-Bowl Dump Cylinder-Lower
24	500336	Pin-Rear Section Cylinder-Lower
25	500338	Pin-Rear Section Pivot
26	A123320-08	Bushing
27	600031	Apron Lift Arm

PART #A125159

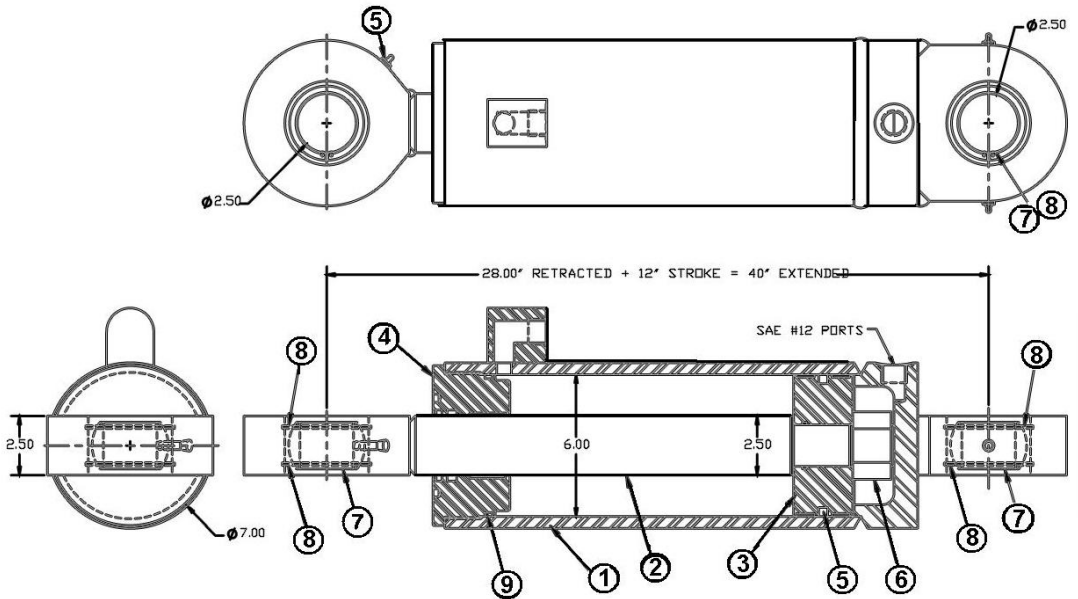

LiftCylinder 18CSHD

Key Number	Part Number	Description
1	125159-10	Barrel Weldment
2	125159-20	Shaft Weldment
3	125159-30	Piston, 6.00" dia.
4	125159-31	Head, 6"00 dia.
5	125159-33	Grease Fitting
6	125159-34	Nut, 1/34" NF Toplock
7	125159-35	Unibal, 2 1/2" ID
8	125159-36	Snap Ring
9	125159-40	Seal Kit

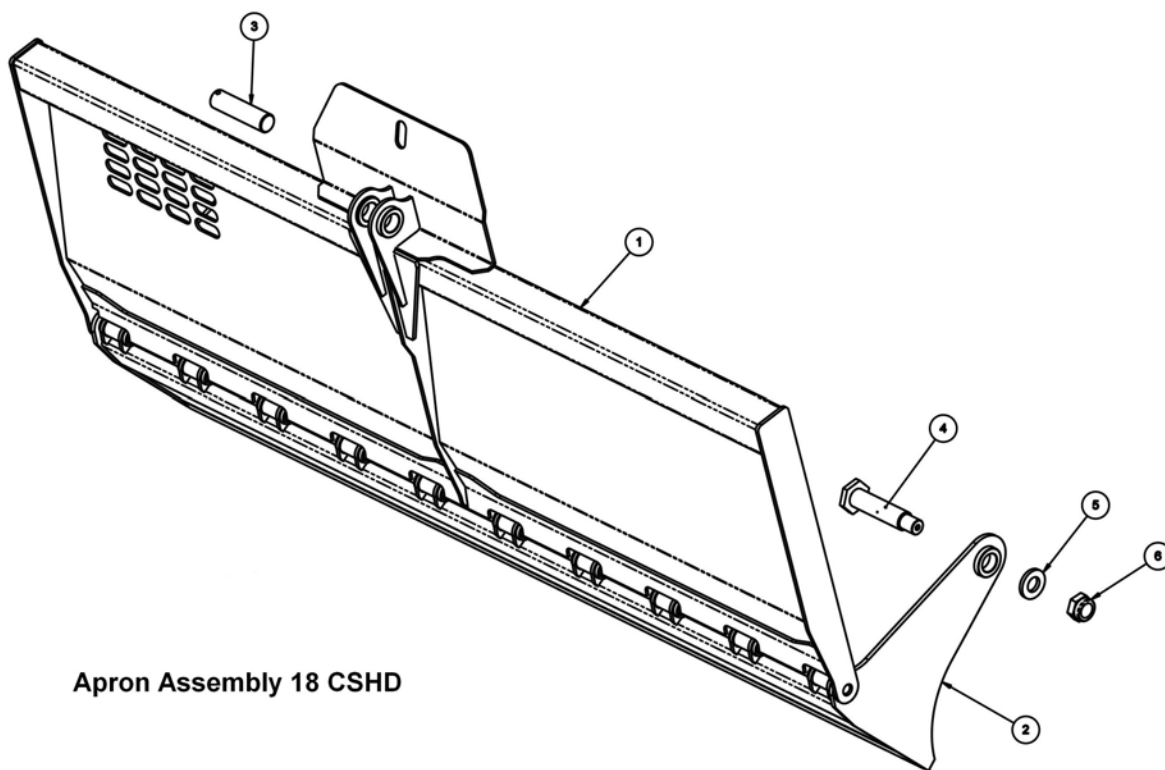

Apron Assembly 18 CSHD

Key Number	Part Number	Description
1	600039	Upper Apron
2	600040	Lower Apron
3	500333	Pin-Apron Lift Arm
4	600000	Assembly-Apron Pivot Pit
5	500330	Washer-Apron Pin Spacer
6	AFN-00033	Jam Nut

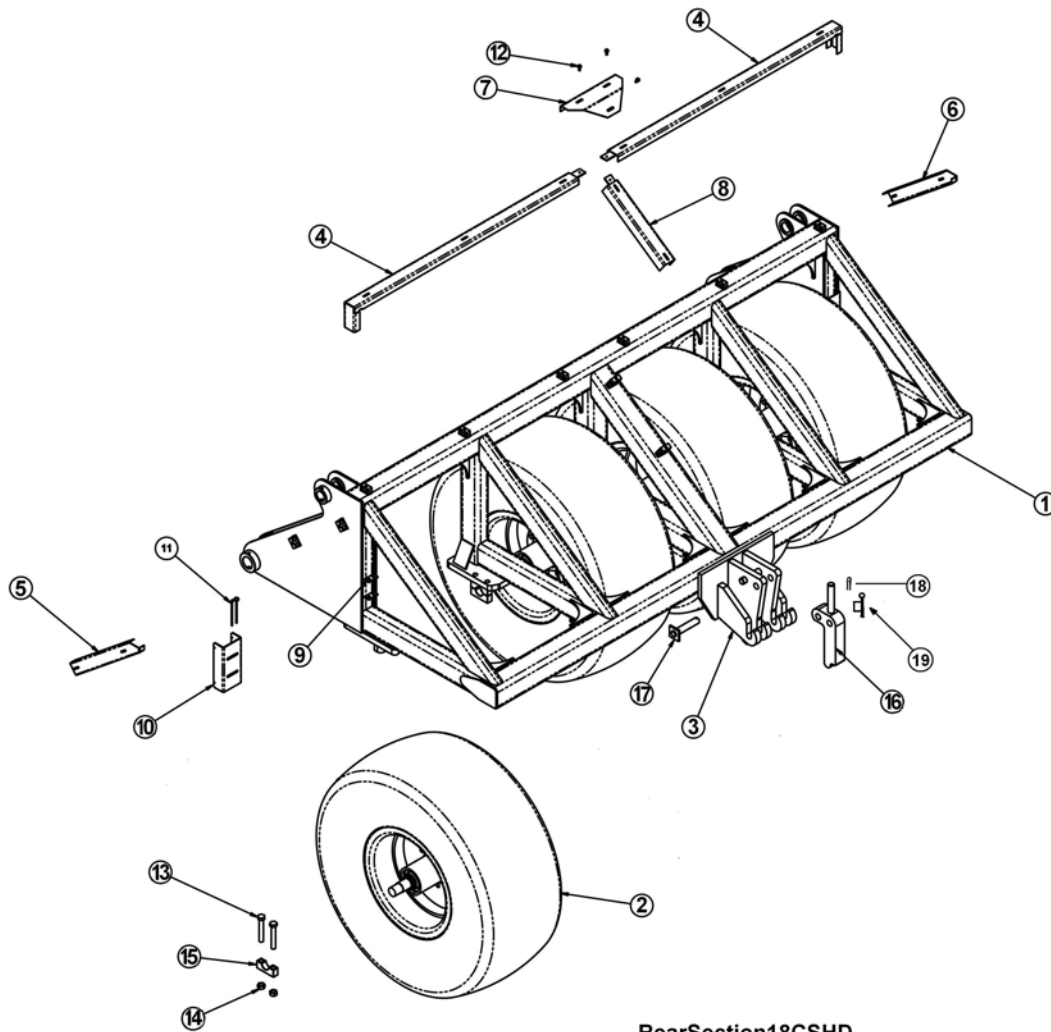

RearSection18CSHD

Key Number	Part Number	Description
1	600025	Frame Assembly-Rear Section
2	600022	Wheel Assembly
3	600018	Quick Hitch
4	600021	Guard-Rear Section Top
5	500408	Guard-Side LH
6	500405	Guard-Side RH
7	500409	Guard-Top Center
8	600020	Guard-Rear Center
9	A125227	Grommet
10	500415	Transport Lock-Rear Section
11	A125226	Quick Release Pin
12	AFB-00094	3/8 NC Flange Head Bolt
13	AFB-00017	1" NF x 6.5 Lg. Hex Bolt
14	AFN-00001	1" NF Locknut
15	500205	Axle Clamp Block
16	600019	Assembly-Locking Lug
17	A123321-98	Pin-Quick Hitch
18	AFP-00001	Cotter Pin
19	A125006	Safety Snap Pin

PART #A125158

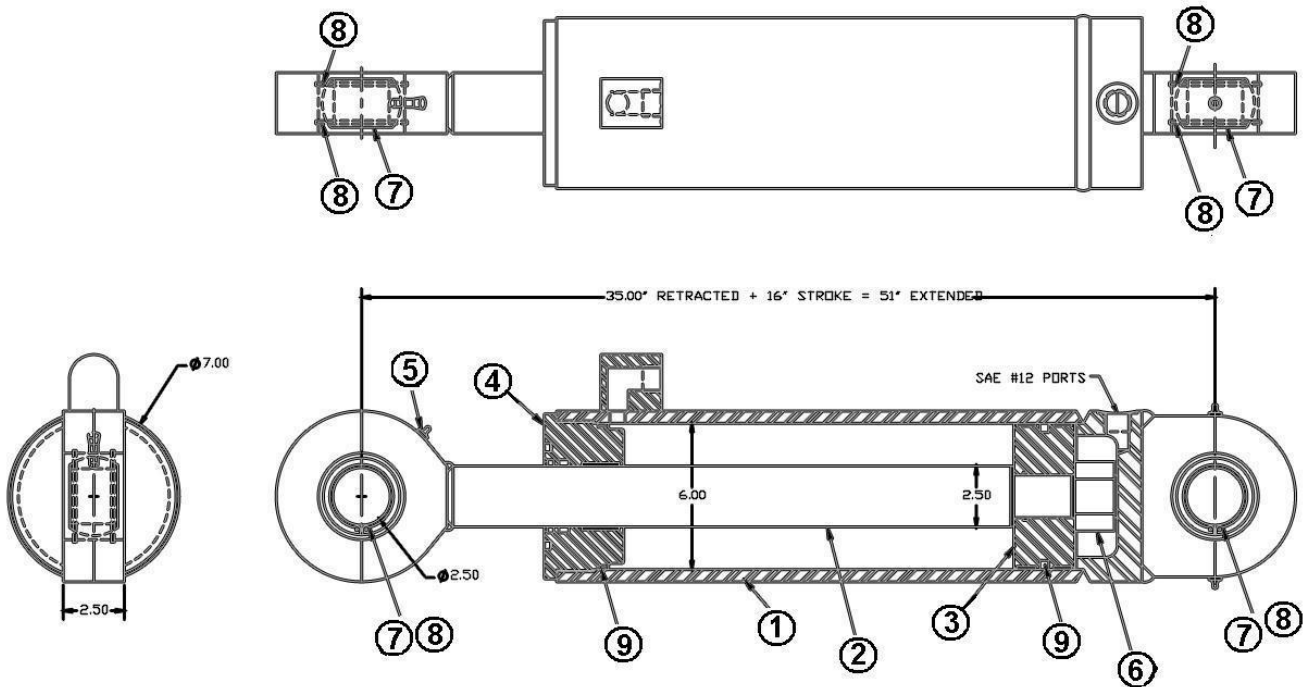

Apron Cylinder 18CSHD

Key Number	Part Number	Description
1	125158-10	Barrel Weldment
2	125158-20	Shaft Weldment
3	125159-30	Piston, 6.00" dia.
4	125159-31	Head, 6.00" dia.
5	125159-33	Grease Fitting, 1/8 NPT
6	125159-34	Nut, 1 3/4" NF Toplock
7	125159-35	Unbal, 2 1/2" ID
8	125159-36	Snap Ring
9	125159-40	Seal Kit

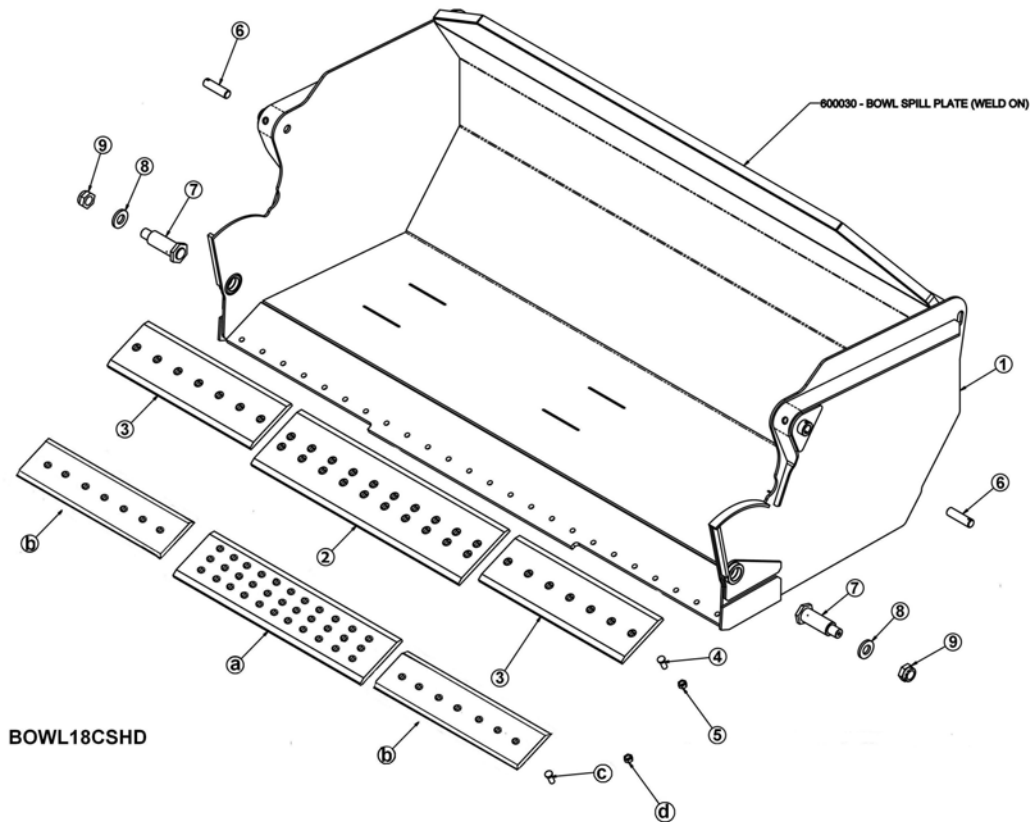

Note: New Style Blades have 24 – bolt hole pattern and 1” plow bolts (blade #'s 500418, and 500419)

Old Style Blades have 25 – bolt hole pattern and ¾” plow bolts (blade #'s A125198 and A125199)

Key Number	Part Number	Description
1	600026	Frame Assembly
2	500418	Center Blade: 10 Hole
3	500419	Corner Blade
4	PB1P-NC-100-0275	1" Plow Bolt x 2 3/4" Lg
5	AFN-00012	1" NC Hex Nut
a	A125198	Center Blade: Old Style 11 Hole
b	A125199	Corner Blade: Old Style
c	PB7P-NC-750-0275	Plow Bolt: 3/4 NC X 2 3/4" gr.8
d	AFN-00006	Nut: 3/4" NC Gr. 8
6	500334	Pin-Upper Bowl Dump
7	600001	Assembly-Bowl Pivot Pin
8	500330	Washer-Apron Pin Spacer
9	AFN-00033	2.00NF-Jam Nut

PART #A125160

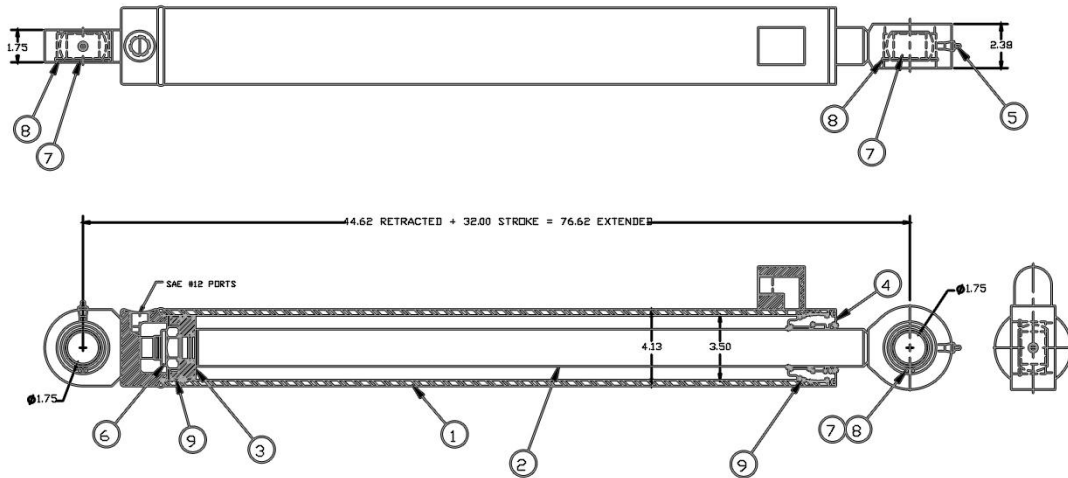

Dump Cylinder CD18HD

Key Number	Part Number	Description
1	A125160-10	Barrel Weldment
2	A125160-20	Shaft Weldment
3	A125160-30	Piston, 3.50" Dia.
4	A125160-31	Head, 3.50" Dia.
5	A125160-33	Grease Fitting, 1/8-NPT
6	A125160-34	Nut, 1 1/4"
7	A125160-35	Uniball, 1 3/4" ID
8	A125160-36	Snap Ring
9	A125160-40	Seal Kit

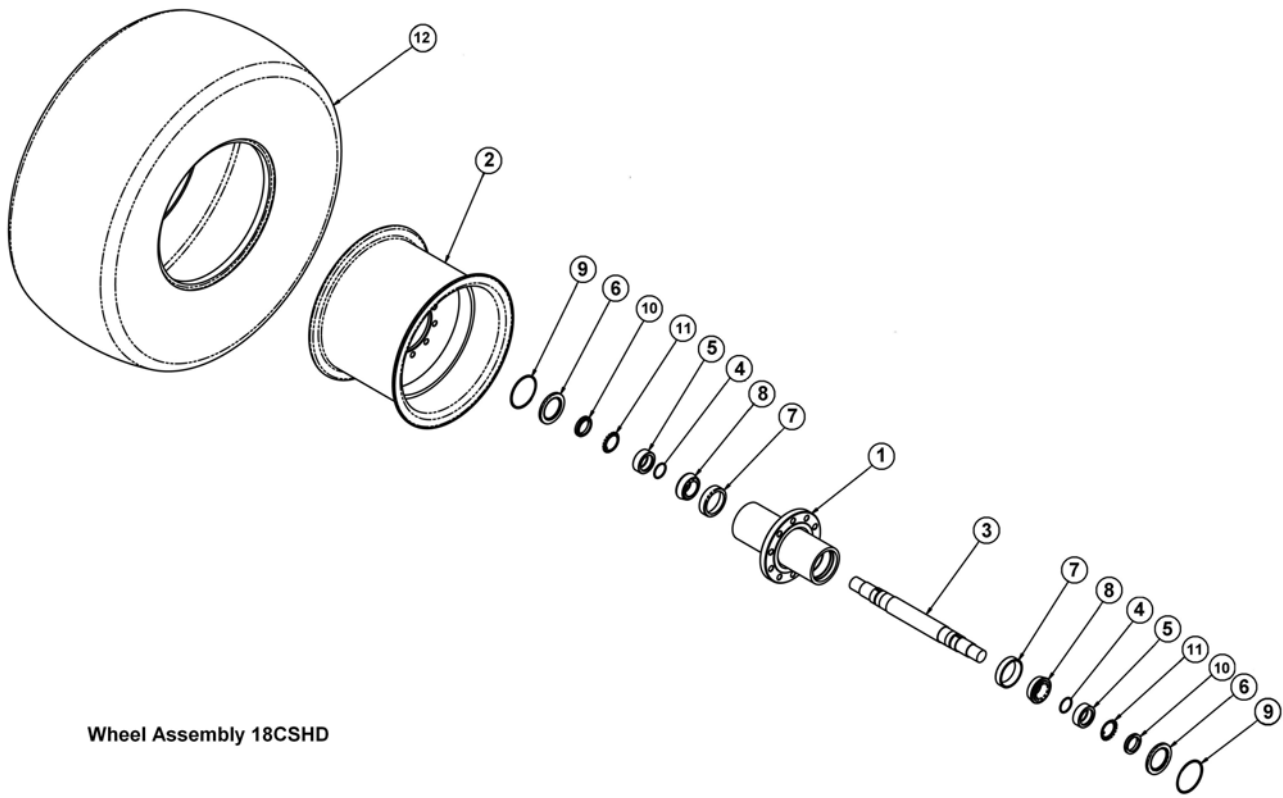

Wheel Assembly 18CSHD

Key Number	Part Number	Description
1	500278	Hub
2	500279	Rim - 25 X 19.5
3	500138	Axle
4	A130H13	O-Ring 2.50 ID X 2.88 OD
5	500140	Spacer Bearing
6	A125214	Seal
7	A14014	Bearing Cup
8	A14015	Bearing Cone
9	A125204	Retaining Ring
10	A125202	Locknut
11	A125203	Lockwasher
12	ATI-00024	Tire-23.5 X 25

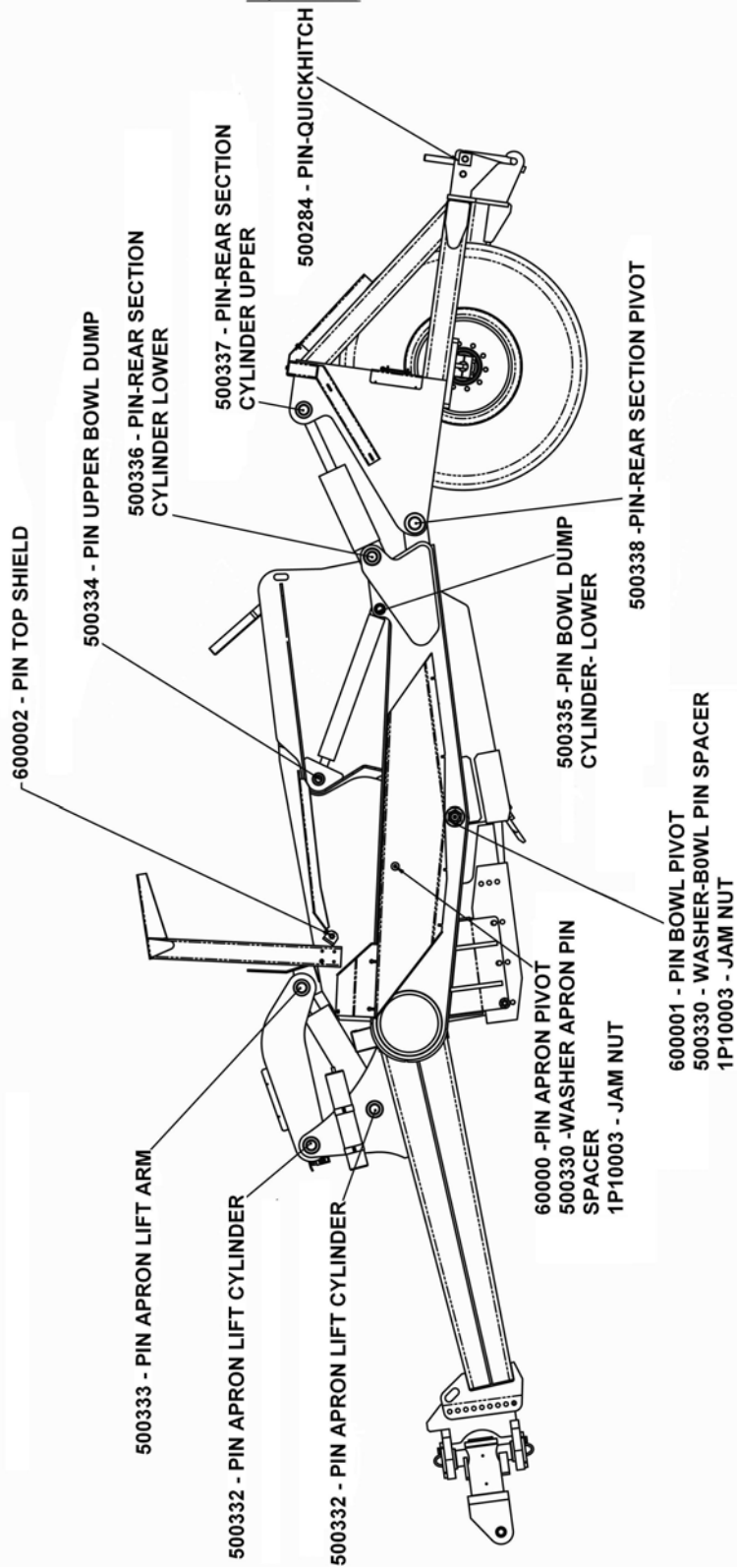

PINS18CSHD