

# **ASHLAND INDUSTRIES**

## Parts Manual

07-17

# ***2014CS-003***



1115 Rail Drive  
P.O. Box 717  
Ashland, WI U.S.A.  
Toll Free: (877) 634-4622  
Business: (715) 682-4622  
Fax: (715) 682-9717

***Ashland Industries***  
*Crafting Quality since 1953!*

[www.ashlandind.com](http://www.ashlandind.com)  
[www.scraperdrawbar.com](http://www.scraperdrawbar.com)

# Table of Contents

## Categorized Listing

<b>ASHLAND SCRAPERS</b>	<b>1</b>
Introduction	1
Operation and Maintenance	2
Safety Guidelines	5
Assembly - 2014-CS-003	6
Ashland Hitch - 601135	7
Apron - 703010	8
Apron Link Arm	10
Bowl - (701015)	11
Wire Harness	12
Front Section Guards - 2014CS	13
Pins - 2014 Front Section	14
Laser Mast - 2014	15
Rear Frame - 706002	16
Rear Hitch - 2014	17
Rear Wheel (2014)	18
Apron Cylinder - 400227	19
Apron Cylinder - (400227) - diagram	20
Bowl Cylinder - (400228)	21
Bowl Cylinder - (400228) - drawing	22
Lift Cylinder - (400258)	23
Lift Cylinder - (400258) - drawing	24
Decals (2014CS)	25
Scraper Decals	26
Hydraulic Manifold (A125211)	28
Hydraulic Plumbing Clamps	29
Axle Service Recommendations	30
Grease Locations CS	32
Hub-Axle Assembly	33
Hub-Axle Disassembly	34
Tire Inflation	35
Maintenance Check List	36
Service: Tire Service	37
Troubleshooting	38
Warranty Statement	39

---

# Table of Contents

## Alphabetized Listing

<b>A</b>		Tire Inflation	35
Apron - 703010	8	Troubleshooting	38
Apron Cylinder - (400227) - diagram	20	<b>W</b>	
Apron Cylinder - 400227	19	Warranty Statement	39
Apron Link Arm	10	Wire Harness	12
Ashland Hitch - 601135	7		
ASHLAND SCRAPERS	1-39		
Assembly - 2014-CS-003	6		
Axle Service Recommendations	30		
<b>B</b>			
Bowl - (701015)	11		
Bowl Cylinder - (400228)	21		
Bowl Cylinder - (400228) - drawing	22		
<b>D</b>			
Decals (2014CS)	25		
<b>F</b>			
Front Section Guards - 2014CS	13		
<b>G</b>			
Grease Locations CS	32		
<b>H</b>			
Hub-Axle Assembly	33		
Hub-Axle Disassembly	34		
Hydraulic Manifold (A125211)	28		
Hydraulic Plumbing Clamps	29		
<b>I</b>			
Introduction	1		
<b>L</b>			
Laser Mast - 2014	15		
Lift Cylinder - (400258)	23		
Lift Cylinder - (400258) - drawing	24		
<b>M</b>			
Maintenance Check List	36		
<b>O</b>			
Operation and Maintenance	2		
<b>P</b>			
Pins - 2014 Front Section	14		
<b>R</b>			
Rear Frame - 706002	16		
Rear Hitch - 2014	17		
Rear Wheel (2014)	18		
<b>S</b>			
Safety Guidelines	5		
Scraper Decals	26		
Service: Tire Service	37		
<b>T</b>			



## Introduction

Thank you for choosing an Ashland scraper for your earthmoving needs. Years of research, testing and successful application have been spent to ensure quality and maximum performance for our customers.

### QUALITY POLICY

**It is our mission to exceed our customers' expectations in quality, delivery, and cost through continuous improvement and customer interaction.**

Please read and understand this manual before attempting to attach or operate this scraper. This manual should always remain with the machine. Be sure and fill out and send in the owners registration form at the beginning of this manual, or you may fill out the form on-line by going to [ashlandind.com](http://ashlandind.com) and click on "Register your Machine" in the parts section drop-down. If you have questions, please feel free to call or email us. You can visit us on-line at [www.ashlandind.com](http://www.ashlandind.com).

Ashland Industries hours of operation are 8:00 a.m. to 5:00 p.m. CST. We can be reached toll free at: 877-634-4622.

### SCRAPER ID NUMBER

The serial number plate for the scraper is located on the apron cylinder weldment on the front hitch of the 2014. The letter and numbers stamped identify the serial number, model number and capacity of the scraper. Please record this serial number for use in ordering parts, warranty issues and to track your equipment if it is ever stolen.

References to serial number breaks on parts are located in the manual with a reference sequence of XXXXX-XXXXX. The beginning number records the serial number start of the use of that part. The ending number is the final serial number use of the part within this machine.



### IMPORTANT

Parts must be ordered through your local authorized ASHLAND dealer. Be sure to state MODEL and SERIAL NUMBER of your machine. Ashland Industries weldable replacement parts are also available to rebuild, modify or update your scraper to current factory specifications.

**ASHLAND SCRAPERS****Operation and Maintenance**

Your Ashland scraper is a durable piece of equipment and with proper care will yield many years of trouble free operation. However, the life of your scraper can be severely shortened by poor maintenance. You must follow consistent maintenance practices and use good quality grease and hydraulic oil (compatible with the power unit's hydraulic system) to insure the longer, most productive use from your scraper.

Your scraper should be greased at all points where grease fittings are provided. **REMOVE TRANSPORT LOCKS** prior to operation. Next, extend and retract all cylinders several times to force out any air from the hydraulic cylinders and lines. Check the oil levels in the tractor hydraulic system and add to maintain the proper level. Care should be used when adding oil or when disconnecting any oil line to keep all dirt out of the oil as dirt is a major factor in the failure of hydraulic components.

When your scraper is placed into operation, the operator will have to "feel out" the amount of depth of cut to obtain maximum loading efficiency. This is usually accomplished by taking a lesser and more uniform cut; however, some soil conditions such as loose sand may require a "pumping action" obtained by taking successive deep cuts and lifting out of cut as the tractor begins to lose power or traction.

- After 8 hours of operation, all bolts should be checked and tightened if necessary and all grease fittings lubricated. Check tire pressures daily. Also, check pins and cutting edges for signs of wear.
- After 50 hours work, all bolts should be rechecked and tightened if necessary. Check wheel bearings and adjust if necessary.
- Check wheel lug nut torque.
  - After first 2 hours of operation.
  - Recheck daily for the next 2 weeks.
  - Tighten wheel lug nuts in a star pattern.
  - Torque wheel lug nut (see Torque Specifications).
- After 300 hours work, clean and repack wheel bearings and replace, if necessary, cutting edges, worn pins, etc.



**Failure to replace worn cutting edges may result in unnecessary wear to the earthmover sides and floor.**

**ASHLAND SCRAPERS****Operation and Maintenance**

Before starting a job, make sure Diggers Hot Line has been contacted and all underground utilities have been properly located (electric, phone and pipelines). Have a clear understanding of all local, OSHA and MSHA rules that apply to the job. Beware of your environment and keep others a safe distance from the machine while familiarizing yourself with the machine's controls. The scraper requires a power source with **TWO** 4-way (double acting) hydraulic control valves.

**Scraper damage can occur if:**

1. The scraper is running over the haul road with the bowl fully raised. On scrapers that have factory installed nitrogen over hydraulic accumulators, the lift cylinders should be lowered 3 to 4 inches to allow the cushioned ride to work properly.
2. The heaped payload repeatedly exceeds the design ISO 6485 Earth-moving machinery-Tractor-scraper volumetric rating.
3. The fully loaded scraper exceeds the 10 mph on smooth haul roads and dramatically less on uneven haul roads.
4. The scraper is being top-loaded without the bowl being fully lowered to the ground prior to placing the material into the bowl.
5. The scraper is being used to level haul roads with the apron closed, not allowing material to enter the bowl.
6. The scraper is being used to load rock.
7. The scraper is being aggressively push loaded with a dozer.
8. A power unit that is above the horsepower rating is pulling the scraper.

These types of damage are not covered by warranty. Warranty only covers defects in material or workmanship and not abuse because of improper use.

**Know the job:**

1. Know the weight of the material to be moved.
2. Lay the job out to take advantage of grades when loading, if possible.
3. Keep hauls as short as possible.
4. Keep haul roads smooth.
5. If more than one unit is on the job, make sure the haul roads are one way and that the operators understand the direction.
6. Brief the operators as to what the job consists of so there is not misunderstanding.
7. Know the moisture content in the material to be moved.
8. Will water be needed for proper compaction?
9. Will drainage be a problem?
10. How many units will be needed to efficiently complete the job?

**Transport the scraper safely:**

1. Always empty scraper.
2. Clean all material from exterior of scraper.
3. Make sure all road rules are followed.
4. Use proper lighting and flagging.
5. Lower scraper bowls to provide just enough clearance over obstacles.
6. Transport at a safe speed to avoid roll over.
7. Reduce speed on curves and when going downhill.

**ASHLAND SCRAPERS****Operation and Maintenance****Apron Opening Guidelines:**

You will need to determine the ideal opening for your soil condition. It is important to have the apron opened prior to loading. To receive the highest production possible, it is important to know the general characteristics of the material that you will be loading. In heavier soils like clay or gumbo, the soil will slab up and remain together after being cut by the blades. In lighter soils, like sand or dry loose top soil, the material will pile up or push after being cut by the blade. Use the suggestions listed below:

**Topsoil with heavy vegetation (12" to 24" opening):**

When cutting undisturbed soils, you will need to open the apron high enough to allow debris to easily enter the scraper bowl. If the apron is opened too high, the rolling up sod will fall out past the apron and hinder the incoming material. If the apron is not adjusted quick enough, the material will bunch or push ahead of the machine. If this happens, you should close the apron and pull out the cut quickly. If you wait too long, you may develop too large a pile to clear the scraper while rising out of the cut. This can cause the power unit to lose traction and possibly cause you to get stuck.

**Clay or loamy material: (6" to 12" opening):**

To cut clay or loam soils, lower the apron to approximately 6" to 12" between the blades and the bottom of the apron. When you first lower the bowl, you'll see the material being cut by the blades and entering the bowl. As you continue to move forward, small clumps will fall past the apron and develop a small pile ahead of the apron. By limiting this apron opening, the small pile will "blade off" any loose material ahead of the machine. Adjustments should be made if large objects such as rocks or deep gouges are within the cut.

**Sand or loose topsoil (15" to 30" topsoil):**

Loading sand or loose top soil is the most difficult type of soil to load. In combination with the larger apron opening, you'll want to operate at a faster ground speed. By traveling faster and lowering the blade deeper than normal, it forces the material into the scraper bowl.

We encourage you to experiment with different apron openings to determine the best condition for your jobsite.



The Apron is designed to capture material inside of the scraper bowl and should not be used as a large blade. Obstructions like large rocks or dense piles may cause the apron to bend inward after prolonged exposure to these conditions.



## Safety Guidelines



**Safety Signal Words:** Please note the use of signal words such as DANGER, WARNING, and CAUTION paired with the safety messages on your scraper. The appropriate signal word for each safety message has been selected using the following guidelines:

- **Danger:** Indicates an imminently hazardous situation that, if not avoided, will result in death or serious injury. This signal word is limited to the most extreme situations—typically for machine components which, for functional purposes, cannot be guarded.
- **Warning:** Indicates a potentially hazardous situation that, if not avoided, could result in death or serious injury. For example, hazards that are exposed when guards are removed. This signal word may also be used to alert against unsafe practices.
- **Caution:** Indicates a potentially hazardous situation that, if not avoided, may result in minor or moderate injury. This signal word may also be used to alert against unsafe practices.

Operator safety is a main concern in designing and developing equipment. Designers and manufacturers include as many safety features as possible. However, every year many accidents occur which could have been avoided by extra thought and a more careful approach to handling equipment. The operator can avoid many accidents by observing the precautions in this section. To avoid personal injury, study the following precautions and insist those working with, or for you, follow them.

Replace any CAUTION, WARNING, DANGER or instruction safety decal that is not readable or missing. Locations of decals are indicated in this booklet.

Do not attempt to operate this equipment under the influence of drugs or alcohol.

Review the safety instructions in the operator's manual with all users annually.

**Operators should be responsible adults who are familiar with machinery and trained in the equipment's operations. Do not allow persons to operate or assemble this unit until they have read this manual and the owner's manual and have developed a thorough understanding of the safety precautions and scraper operation.**

**Assembly - 2014-CS-003**

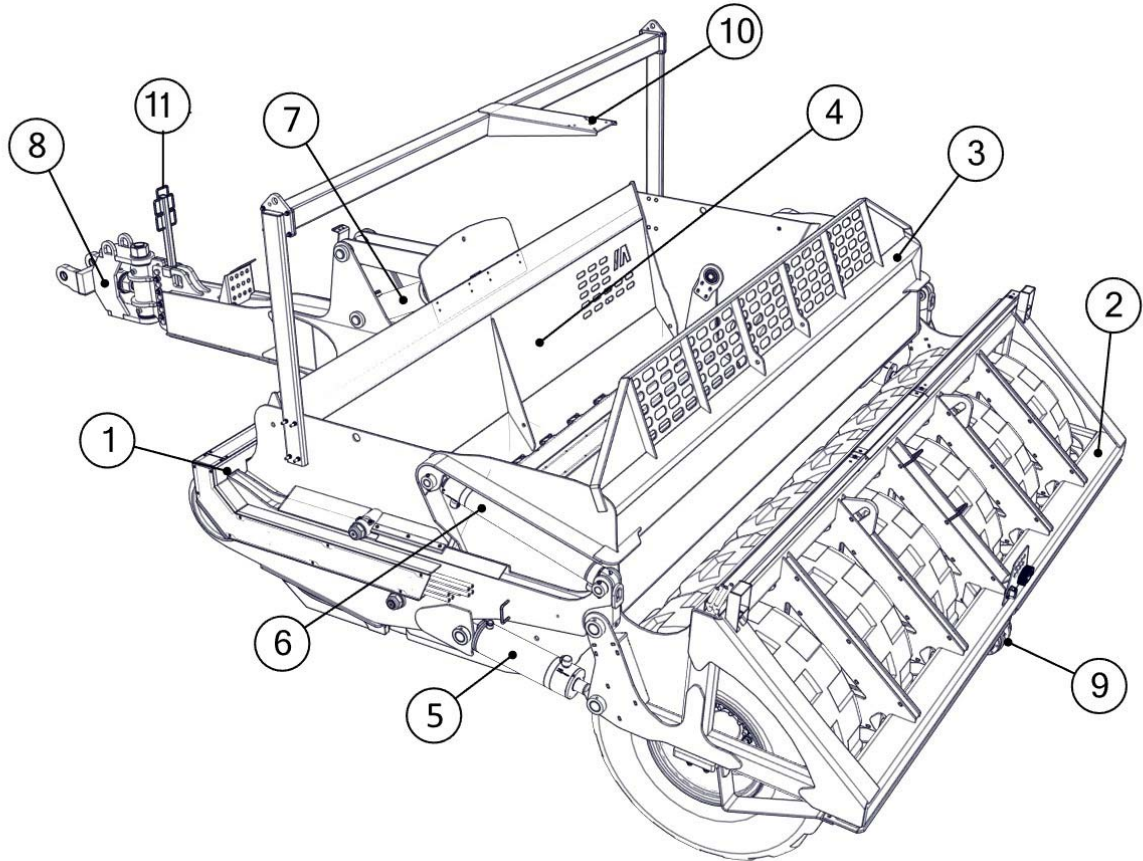

ITEM	PART	DESCRIPTION
		2014-CS MAIN SCRAPER ASSEMBLY
1	704010	Front Section
2	706002	Rear Frame
3	701015	Bowl
4	703010	Apron
5	400258	Lift Cylinder
6	400228	Bowl Cylinder
7	400227	Apron Cylinder
8	600903	Front Hitch
9	600948	Rear Hitch
10	600890	Laser Mast (Optional)
11	600912	Line Keeper

**ASHLAND SCRAPERS**

**Ashland Hitch - 601135**

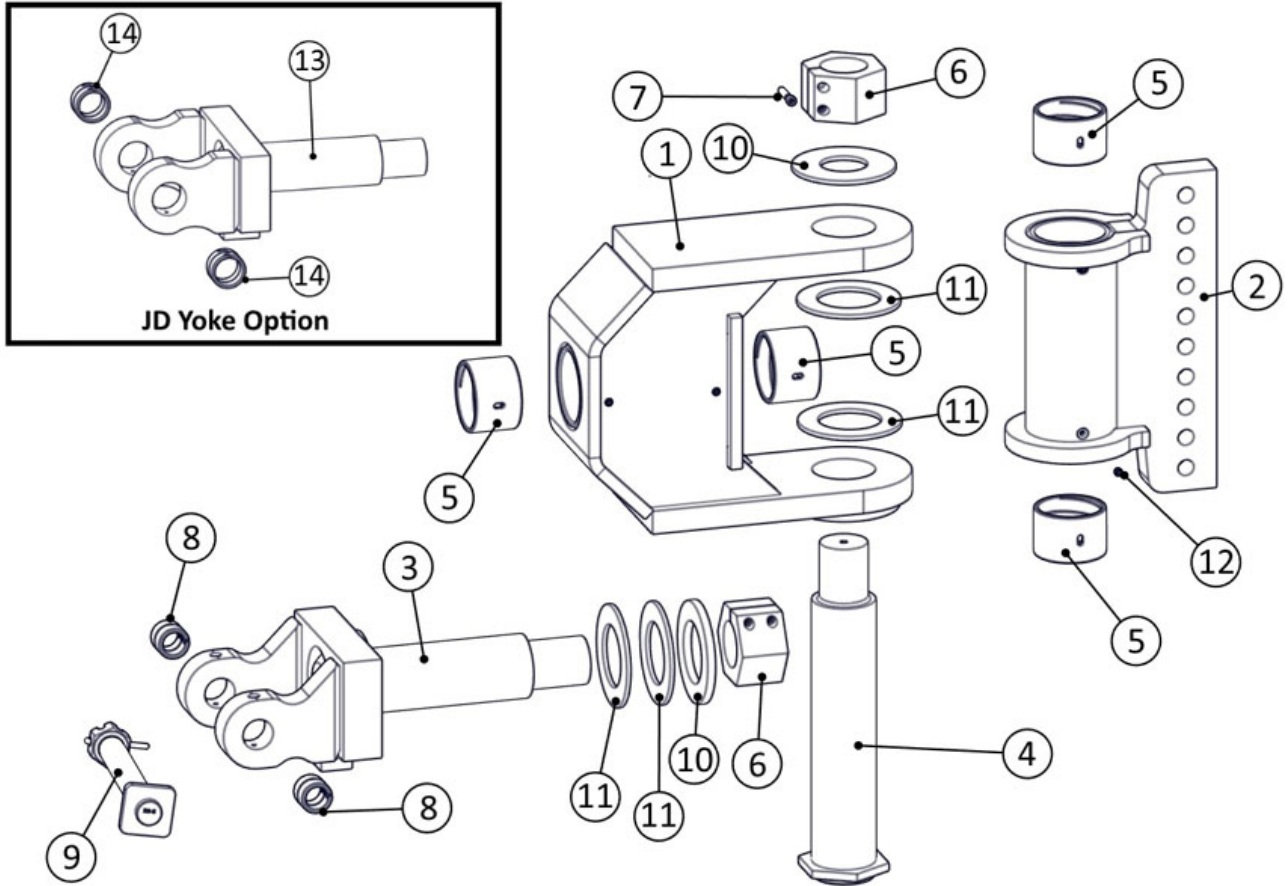

ITEM	PART	DESCRIPTION
1	601139	Hitch: Housing
2	601138	Hitch: Vertical 10-hole bracket
3	601090	Yoke: Ashland Swivel
4	600925	Pin: Vertical 4"
5	400312	Bushing: 4 X 4 1/2" X 3"L
6	601026	Nut: Clamping 3"-8
7	AFB-00184	Bolt: 3/8 X 2" Cap Screw
8	A123343	Bushing: Ashland, Steel Spring
9	CNH-84260964	Hitch Pin w/nut & cotter pin
10	501937	Washer: Steel, 3 1/8 ID
11	400318	Washer: UHMW-R 4ID X 1/4"
12	14505	Fitting: Grease Zerk
13	601121	Yoke: JD, 60mm Swivel (Optional)
14	400216	Bushing: JD, Steel Spring (Optional)

**Apron - 703010**

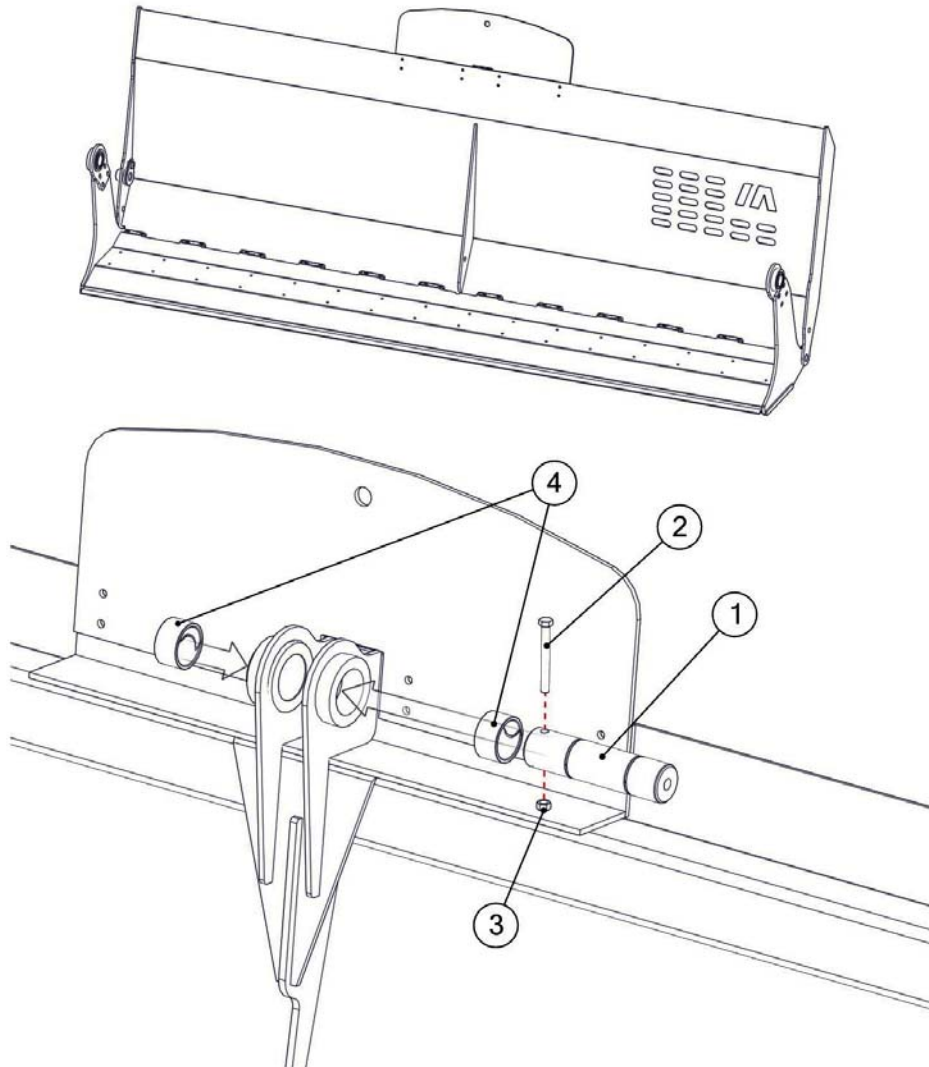

ITEM	PART	DESCRIPTION
1	502197	Pin: 2 1/2 X 10" Greasable
2	AFB-00012	Bolt: 1/2 X 4 1/2" Gr 8 Hex Cap
3	AFN-00060	Nut: 1/2" Gr 8
4	400175	Bushing: 3 OD X 2 1/2" ID X 1 5/8"L

**Apron - 703010**

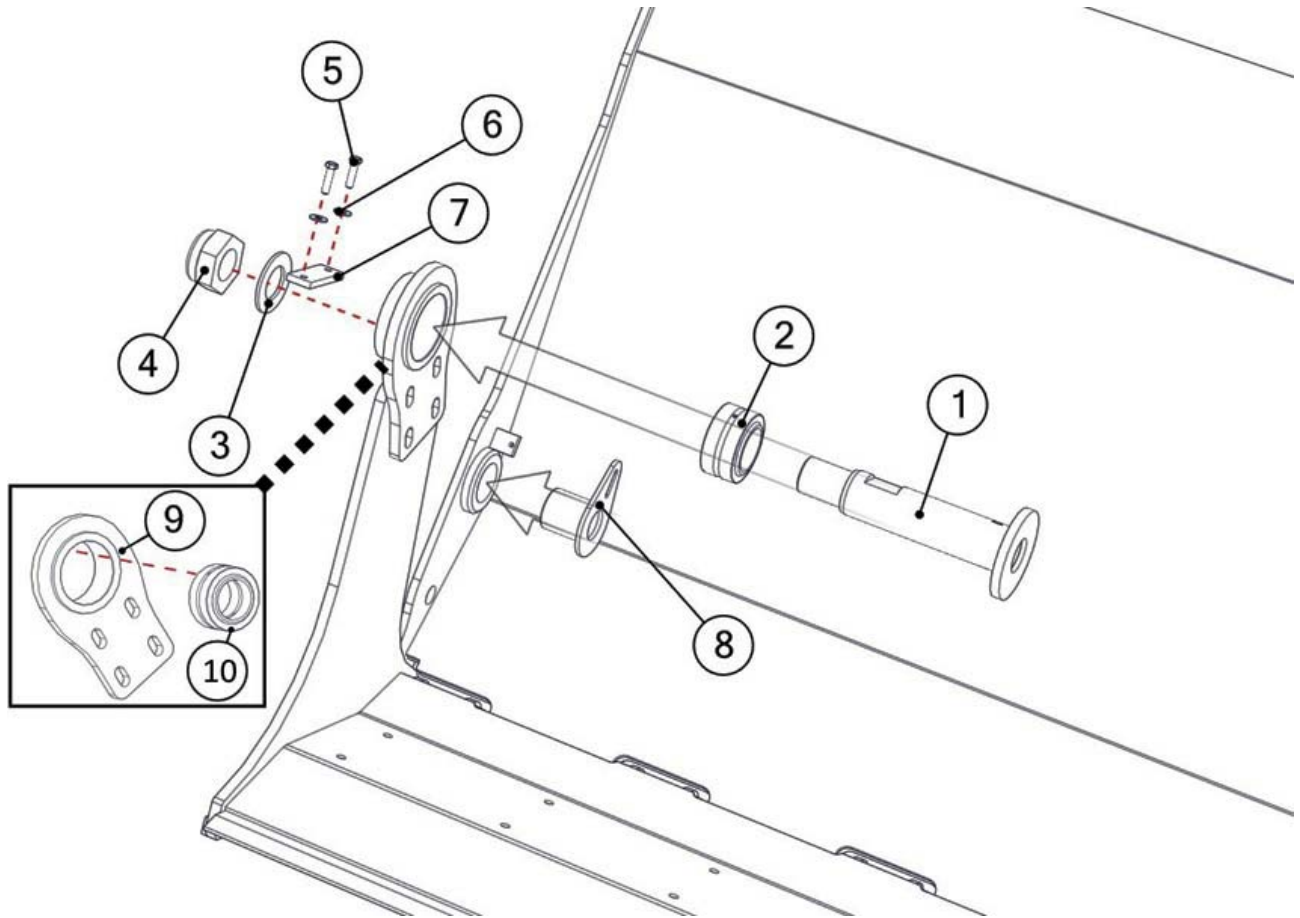

ITEM	PART	DESCRIPTION
1	600850	Pin: 2 1/2" Dia. Greasable
2	A125159-35	Bushing: 2 1/2" ID
3	502202	Washer: 2.031 ID X 3.653 OD X 3/16"
4	AFN-00033	Nut: 2" Lock
5	AFB-00027	Bolt: 3/8 X 1 1/2" Gr. 5 Hex Cap
6	AFW-00010	Washer: 3/8" Flat
7	502369	Keeper: Apron Pin
8	600930	Pin Lock: Apron
9	502371	Support: Boss
10	A125159-35	Bushing: 2 1/2" ID Ball
	AFB-00037	(Fasteners) Bolt: 3/4 X 2" Gr 8 Hex Cap
	AFN-00006	(Fasteners) Nut: 3/4" Hex
	AFW-00007	(Fasteners) Washer: 3/4" Flat

## Apron Link Arm

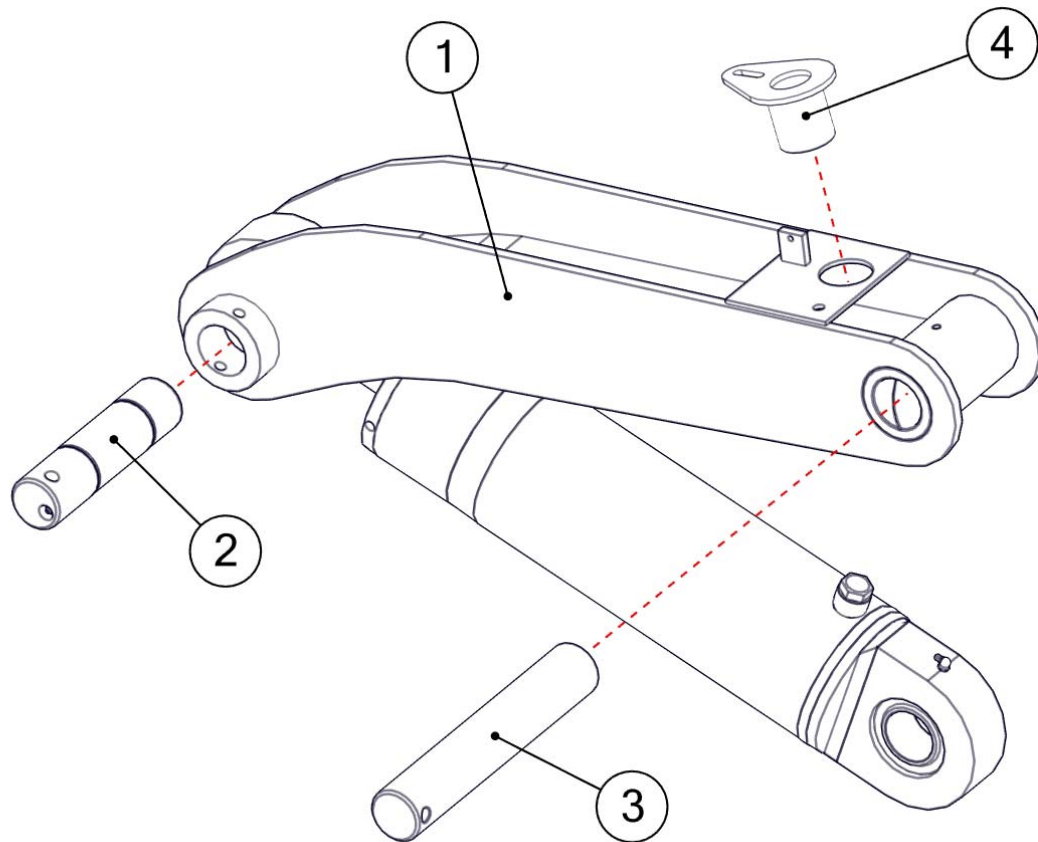

ITEM	PART	DESCRIPTION
1	600604	Apron Arm Link (Banana)
2	502197	Pin: 2 1/2 X 10" Greasable
3	501895	Pin: 2 1/2 X 14.50"
4	600930	PIN LOCK-APRON (LOCK STORAGE LOCATION)

**Bowl - (701015)**

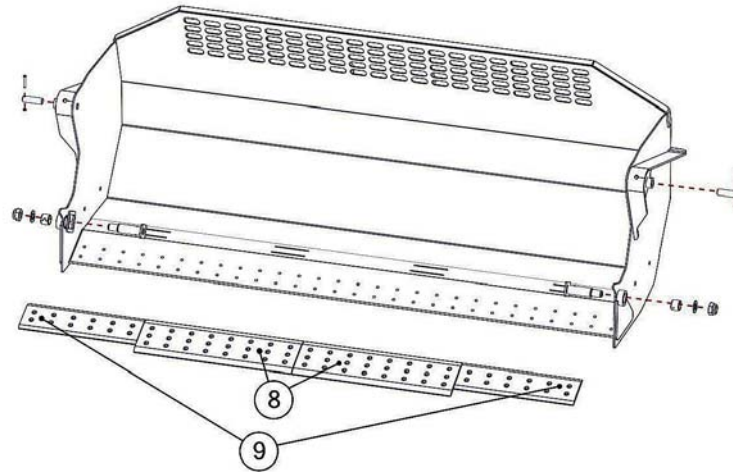
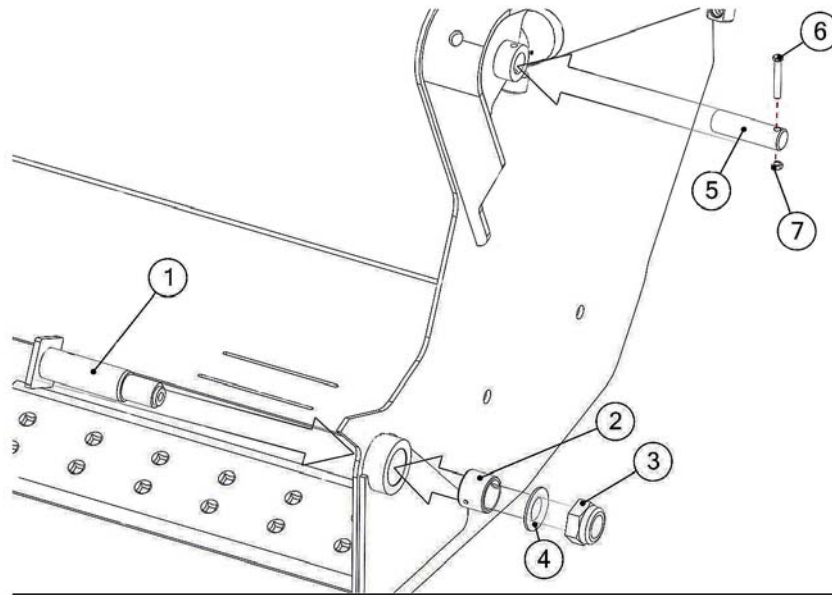

ITEM	PART	DESCRIPTION
	701015	BOWL - 2014
1	600875	Pin: 2 1/2" Dia. Greasable, Sq. Head
2	400057	Bushing: 3 OD X 2 1/2 ID X 2 1/4" L Spring
3	AFN-00033	Nut: 2" Lock Nut
4	502202	Washer: 2.031 ID X 3.653 OD X 3/16"
5	501894	Pin: 1 3/4 X 6.25"
6	AFB-00113	Bolt: 1/2 X 3 1/2" Gr 8 Hex Cap
7	AFN-00015	Nut: 1/2" Gr 8 Hex
8	502661	Blade: Center 7/8 X 13 X 47.88" Straight Rev.
9	502662	Blade: Corner 3/4 X 1- X 35.82" Straight Rev.
	PB7P-NC-074-0114	(FASTENERS) Bolt: Plow 3/4" X 2 1/4" Gr. 8
	AFN-00006	(FASTENERS) Nut: 3/4" Gr 8 Hex

**Wire Harness**

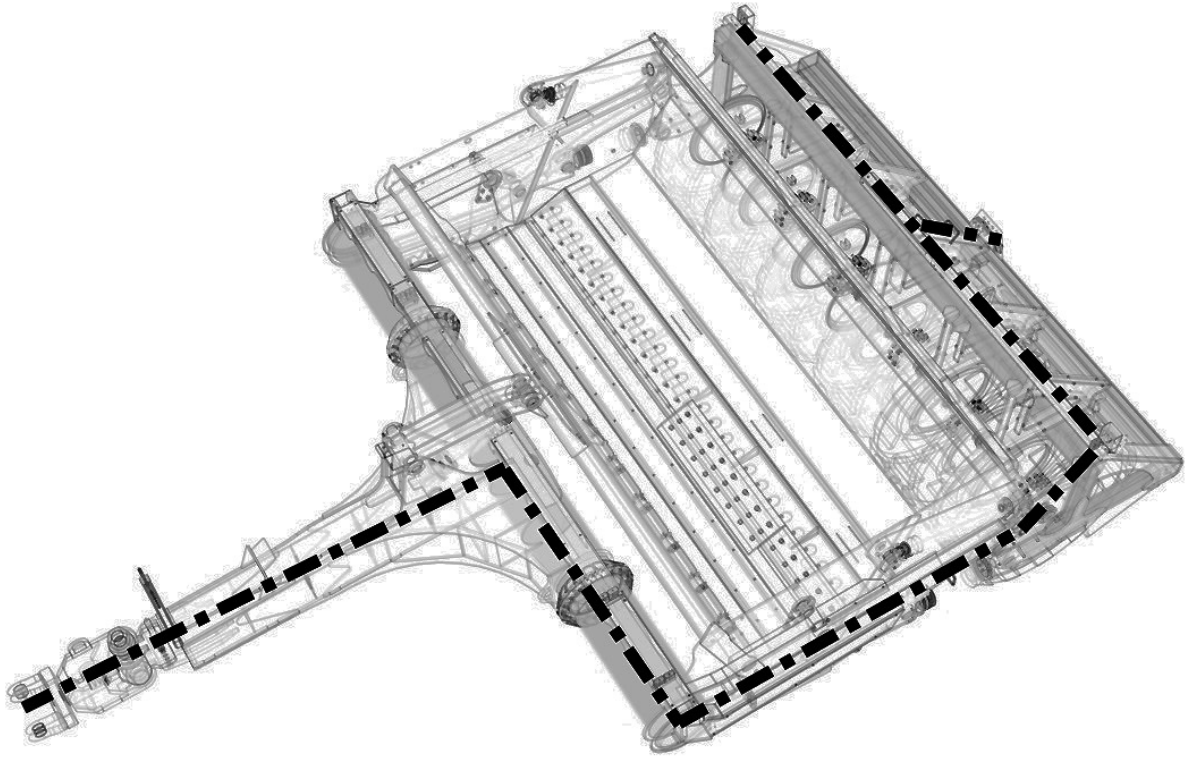

PART	DESCRIPTION
400295	Wire Harness



**ASHLAND SCRAPERS**

**Front Section Guards - 2014CS**

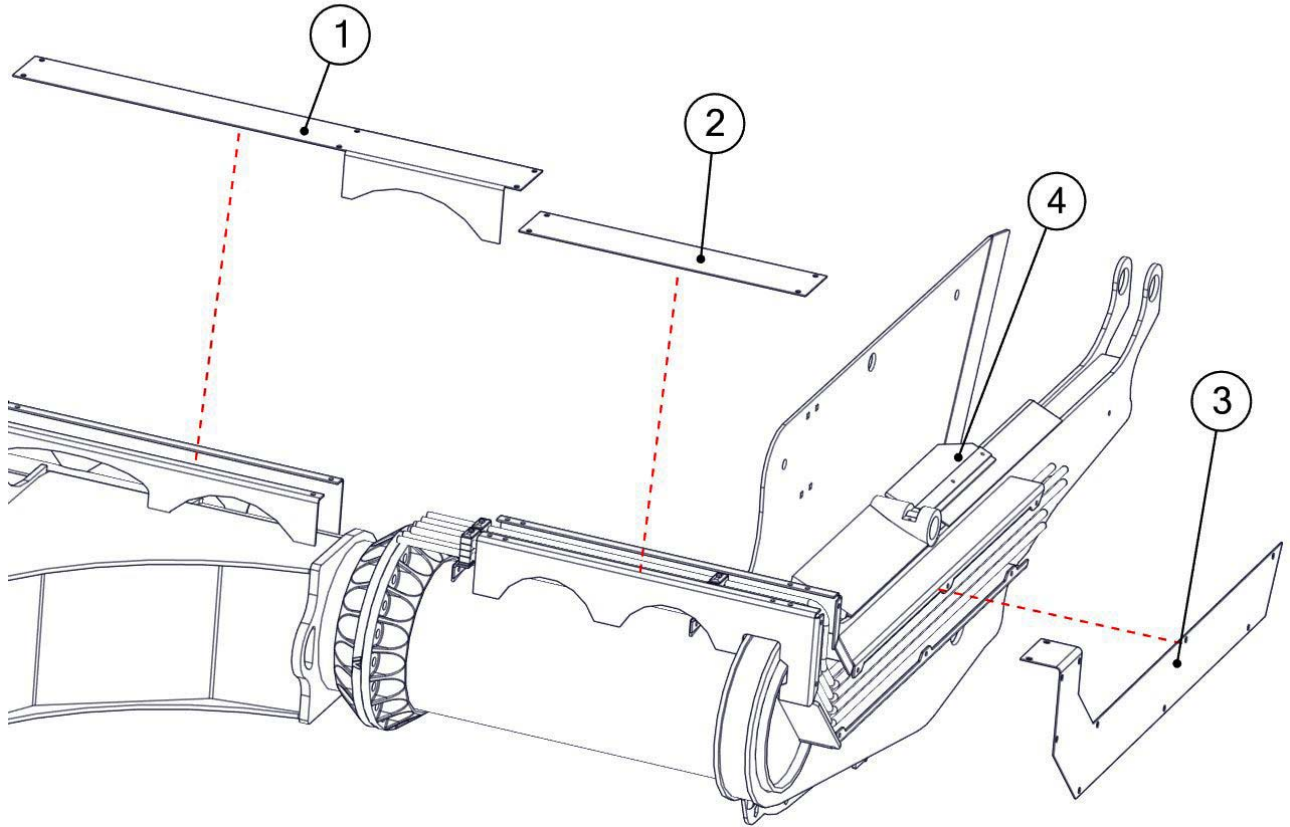

ITEM	PART	DESCRIPTION
1	502569/502570	Guard: Front Left/Front Right
2	502561	Guard: Cap, Front
3	502606/502607	Guard: Trailing Arm Left Side/Trailing Arm Right Side
4	502597	Shield: Rubber Wiper Guard
	AFB-00128	Bolts: 3/8 X 1" Flange

**Pins - 2014 Front Section**

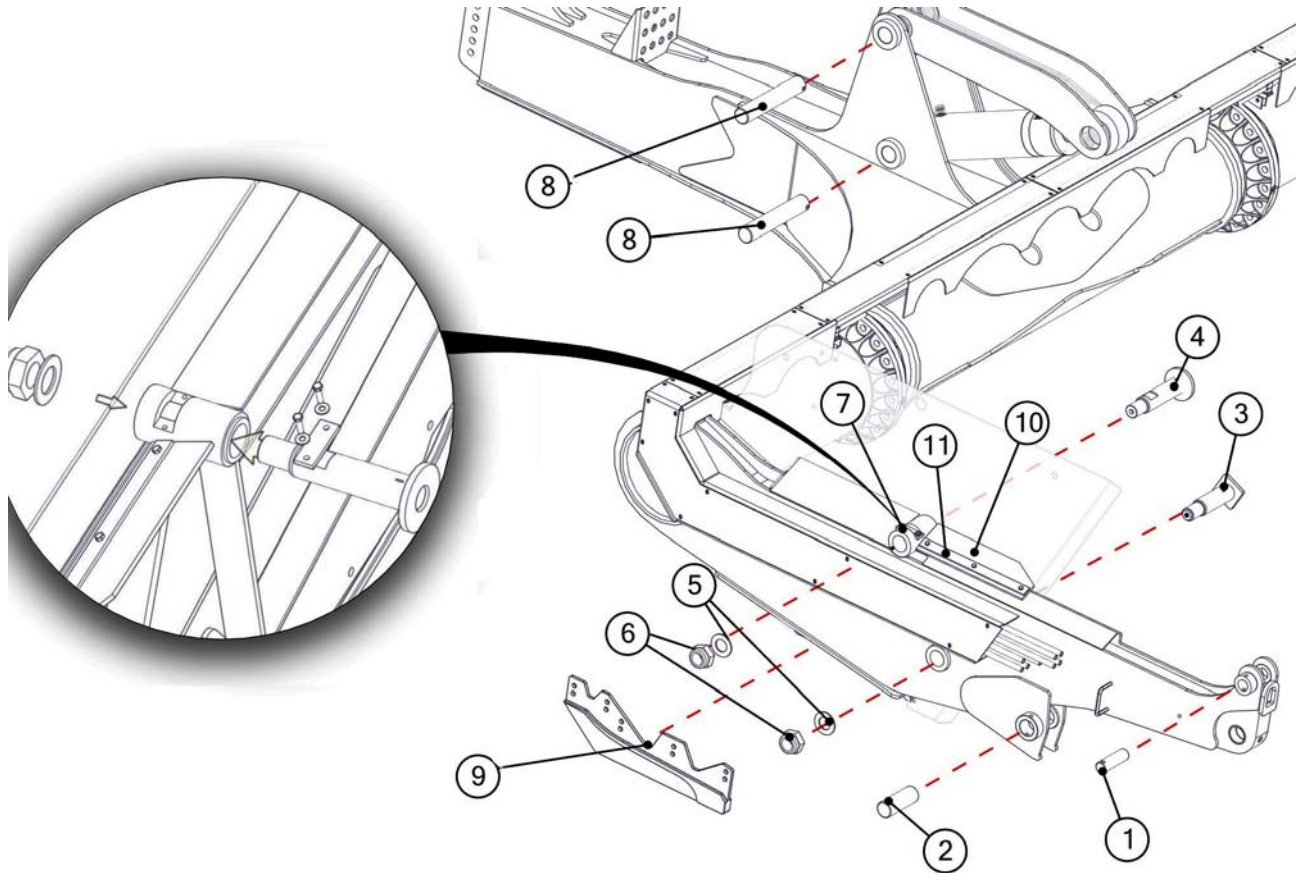

ITEM	PART	DESCRIPTION
1	501894	Pin: 1 3/4 X 6.25"
2	502353	Pin: 2 1/2" X 7" 0.656" Keeper
3	600875	Pin: 2 1/2" Dia., Greasable, Square Head
4	600850	Pin: 2 1/2" Dia., Greasable, Round Head
5	502202	Washer: 2.031 ID X 3.653 OD X 3/16" Thick
6	AFN-00033	Nut: 2" Lock Nut
7	502369	Keeper: Apron Pin
8	501895	Pin: 2 1/2 X 14 3/4"
9	400073	Blade: Router Bit
	AFB-00079	Bolt: 5/8 X 1 1/2 Gr. 8 Hex Cap
	AFN-00050	Nut: 5/8 Hex Nut
10	502597	Shield: Rubber Wiper Guard
11	502596	Plate: Bolting, Rubber Guard
	AFB-00128	Bolt: 3/8 X 1" Flange

**Laser Mast - 2014**

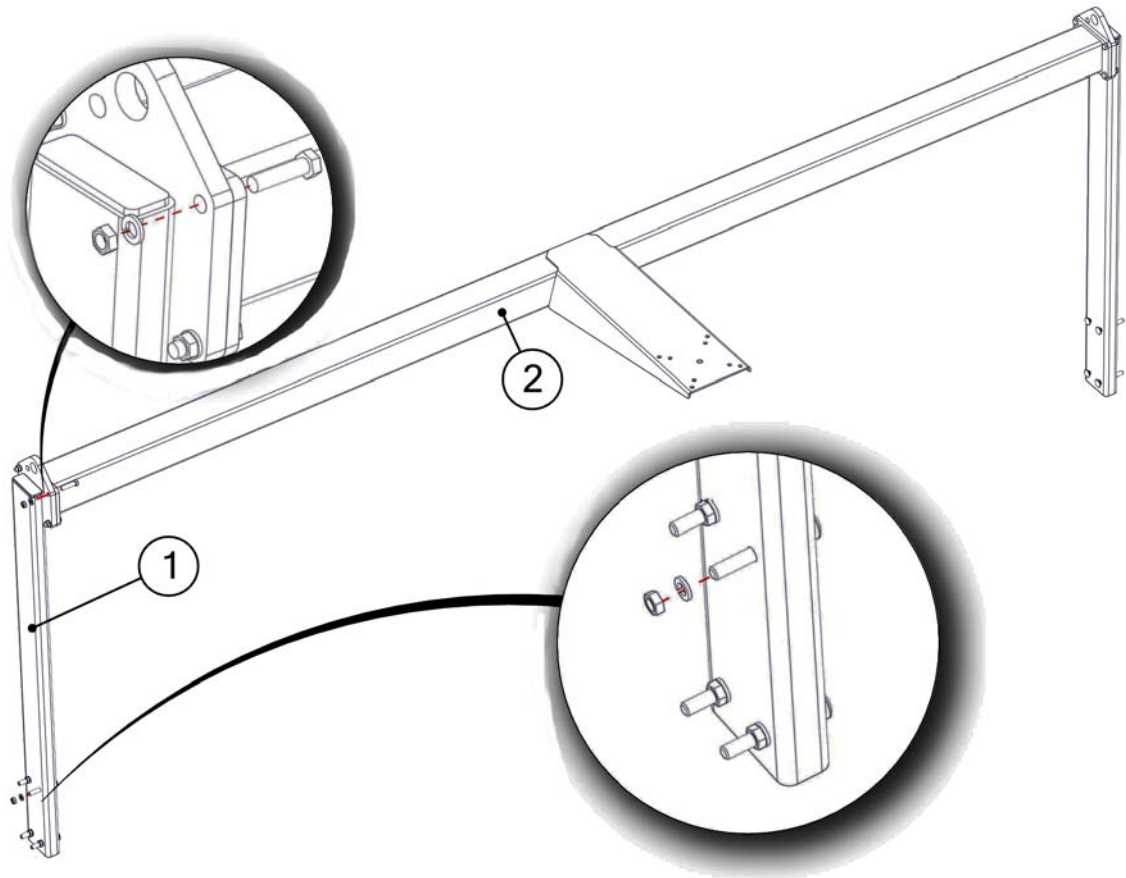

ITEM	PART	DESCRIPTION
1	600891/600892	Mount Assembly: Laser Mast Left/Laser Mast Right
	AFB-00144	Bolt: 1/2" X 2" Gr 8 Hex Cap
	AFW-00030	Washer: 1/2" Split Lock
	AFN-00060	Nut: 1/2" Gr 8 Hex
2	600893	Mount Assembly: Laser Mast Center
	AFB-00121	Bolt: Carriage 1/2" X 4" Round
	AFW-00030	Washer: 1/2" Split Lock
	AFN-00060	Nut: 1/2" Gr 8 Hex

**Rear Frame - 706002**

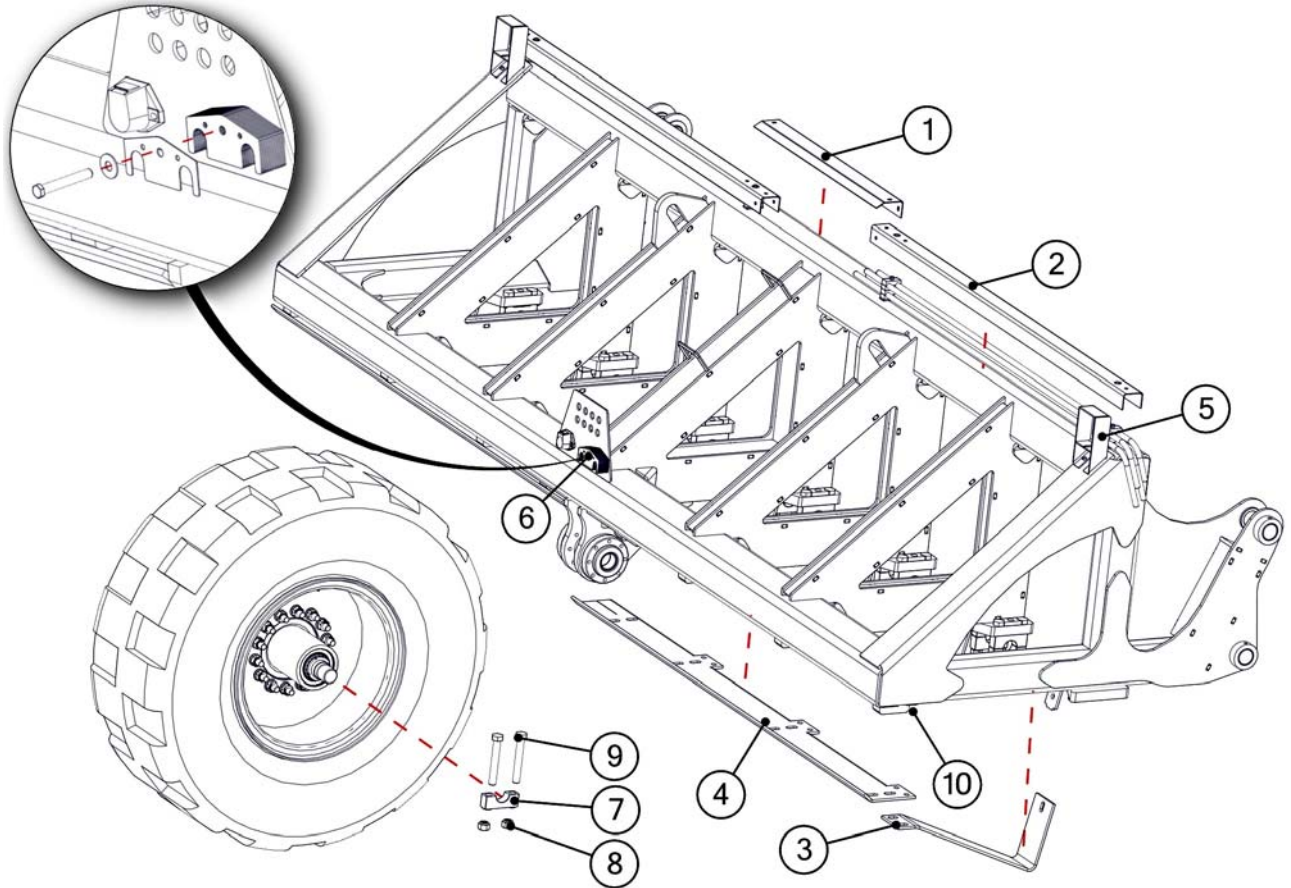

ITEM	PART	DESCRIPTION
	706002	REAR FRAME
1	502591	Guard: Top Cover Center
2	502560	Guard: Top Cover Left & Right
3	502546	Mud Scraper: Support (optional)
4	502588/502542	Mud Scraper: Left Base/Right Base (optional)
	AFB-00005	Bolt: 3/4" X 2 1/2" (Fastener)
	AFW-00002	Washer: 3/4" Split Lock (Fastener)
5	600909	Guard: Light Housing, Bolt-on
6	A125410	Light: 4" Round Amber LED
7	500205	Mount Block: Axle
8	AFN-00074	Nut: 1" Lock Nut
9	AFB-00024	Bolt: 1 X 7" Gr. 8 Hex Cap
10		Weld-on Optional mud scraper blocks

**Rear Hitch - 2014**

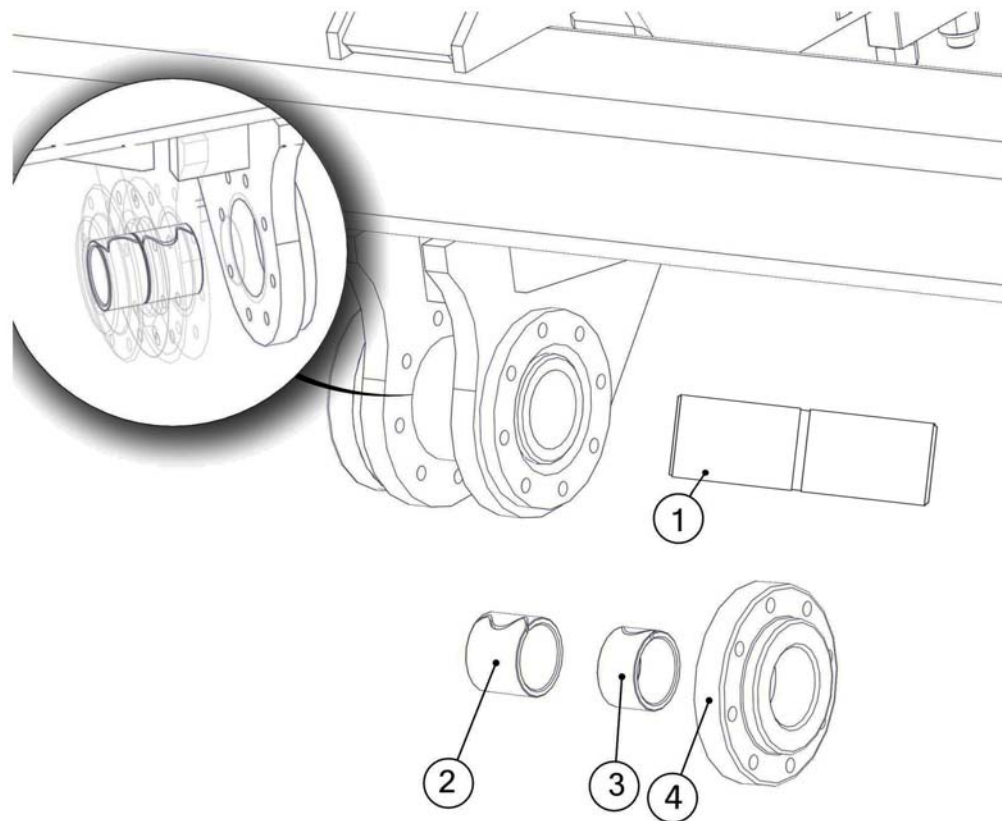

ITEM	PART	DESCRIPTION
1	DB-1018	Ashland Hitch Bushing: 60mm to 1.50"ID @ 6.375" L
2	A125397 (JD Bushing)	Bushing: 2 1/4" L Spring
3	400287	Bushing: 1 5/8"L for JD Adapt. (Optional)
4	502751	Boss: Stepped JD Adapter (Optional)
	AFB-00113	Bolt: 1/2 X 3 1/2" Gr 8 Hex Cap (Opt.)
	AFW-00030	Washer: 1/2" Split Lock (Opt.)
	AFN-00015	Nut: 1/2" Gr 8 Hex (Opt.)
5	A123299-07	Nut: 1/2" Gr 8 Hex (Opt.)

**Rear Wheel (2014)**

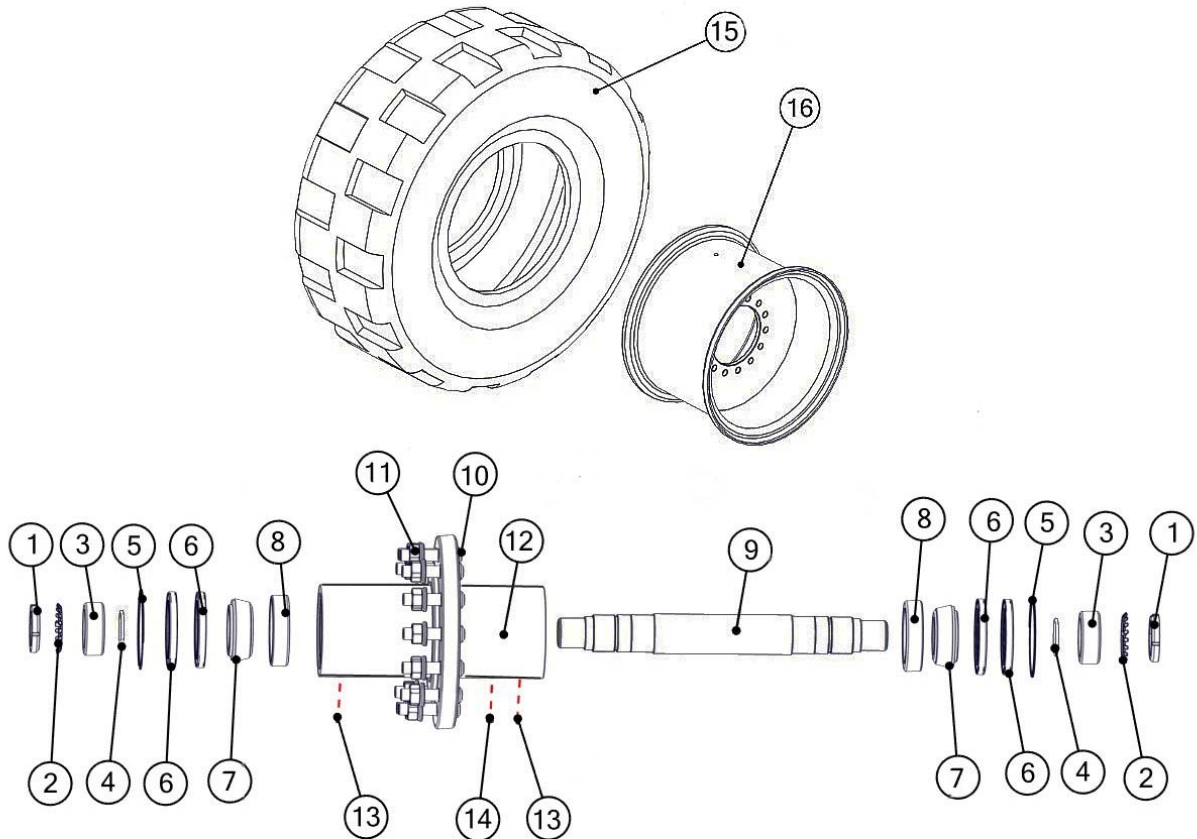

ITEM	PART	DESCRIPTION
1	A125202	Nut: Spindle 2 3/4"
2	A125203	Washer: Lock
3	500140	Spacer: Bearing
4	A130H13	Seal: O-Ring 2 1/2 X 2 7/8 X 3/16"
5	A125204	Retaining Ring: Spindle 6"
6	400221	Seal: Grease
7	A14015	Bearing: Cone Outer
8	A14014	Bearing: Cup Outer
9	502424	Axle: 3" dia. X 25"L
10	A125236	Stud
11	A125229	Nut: Wheel Flanged
12	600705	Hub: 14-Hole
13	14505	Fitting: Grease 1/8"
14	A125466	Vent: Pressure Relief
15	ATI-00011	Tire: 20.5-25" 20 Ply
16	400068	Wheel 17 X 25" 14 Hole
17		Wheel 17 X 25" 14 Hole

**Apron Cylinder - 400227**

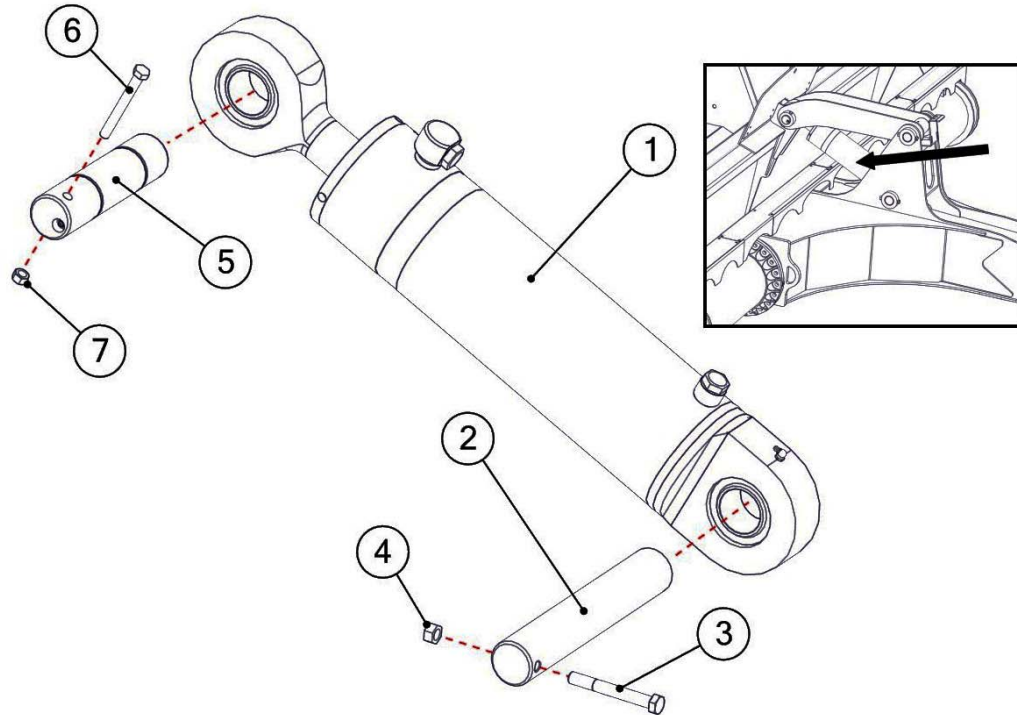

ITEM	PART	DESCRIPTION
1	400227	APRON CYLINDER (6 X 15.88)
2	501895	Pin: 2 1/2 X 14 3/4"
3	AFB-00046	Bolt: 5/8" X 5" Gr 8 Hex Cap
4	AFN-00050	Nut: 5/8" Gr 8 Hex
5	502197	Pin: 2 1/2 X 10" Greasable
6	AFB-00012	Bolt: 1/2 X 4 1/2" Gr 8 Hex Cap
7	AFN-00060	Nut: 1/2" Hex
	432024P	Seal Kit

**ASHLAND SCRAPERS**

**Apron Cylinder - (400227) - diagram**

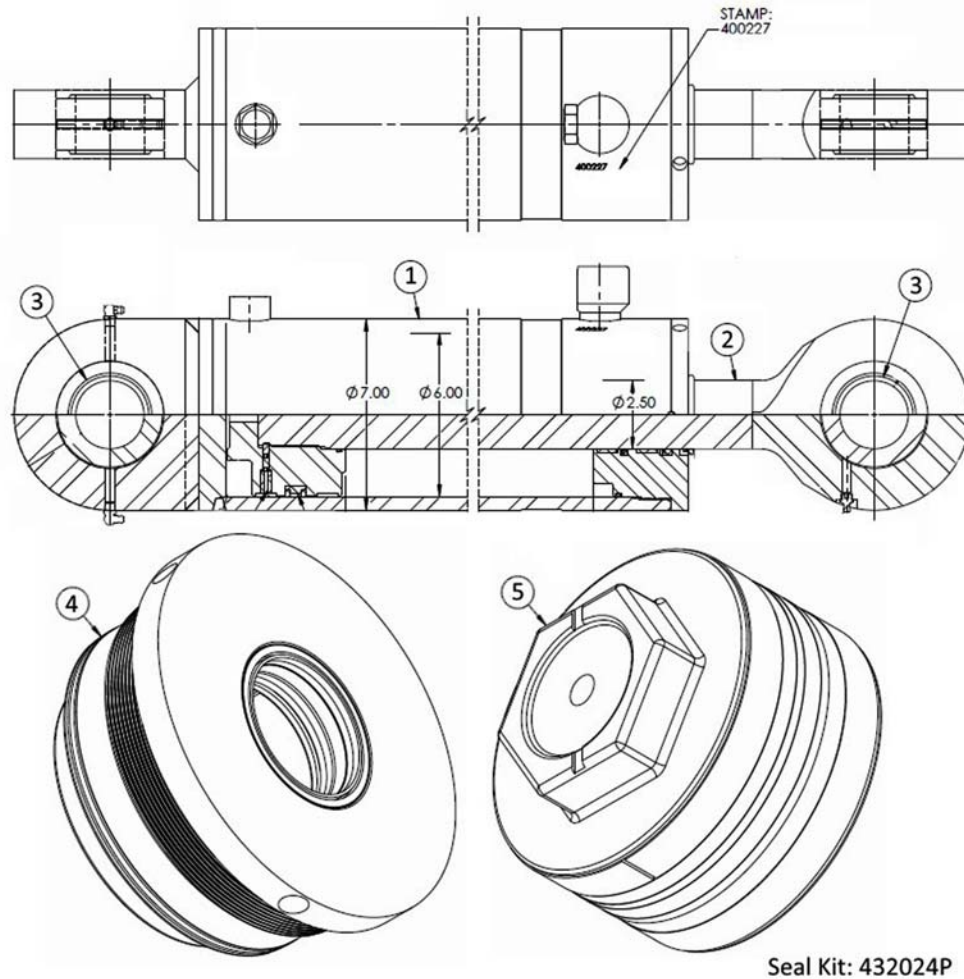

ITEM	PART	DESCRIPTION
1	201878P	Barrel
2	301545P	Rod
3	A125159-35	Bearing: Spherical 2.5
4	511193P	Head 6.00 X 2.50 IT
5	411085P	Piston 6.00 X 2.38-12 UN CT



**Bowl Cylinder - (400228)**

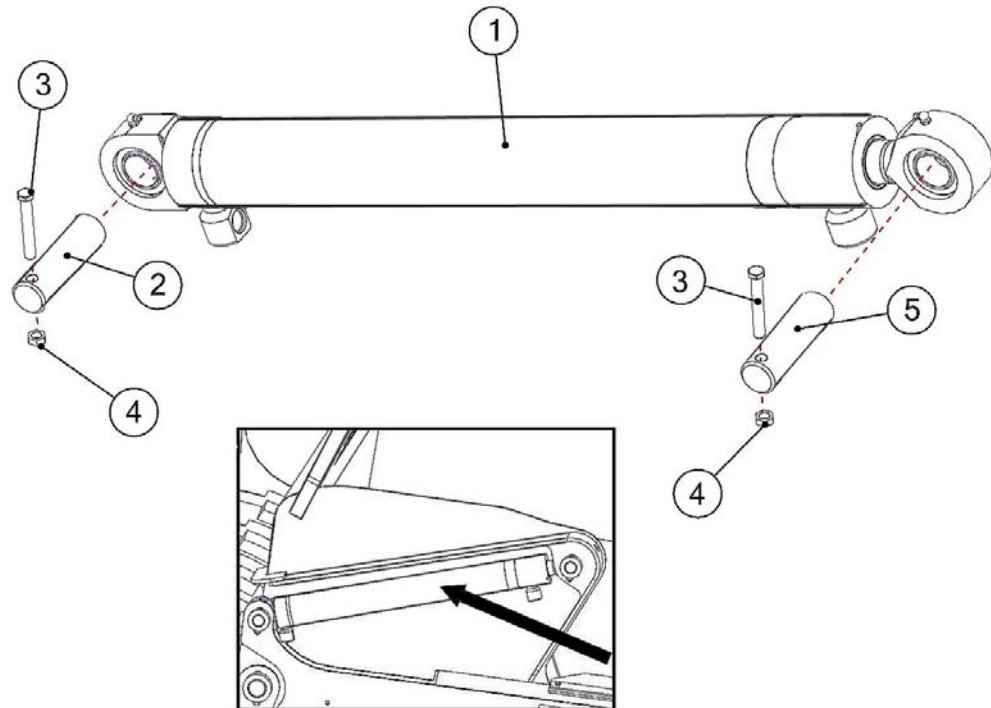

ITEM	PART	DESCRIPTION
1	400228	Bowl Cylinder (3.5 X 31.88 X 2")
2	501894	Pin: 1 3/4 X 6"
3	AFB-00113	Bolt: 1/2 X 3 12" Gr 8 Hex Cap
4	AFN-00015	Nut: 1/2" Gr 8 Hex
5	502924	Pin: 1 3/4 X 6.5"

**ASHLAND SCRAPERS**

**Bowl Cylinder - (400228) - drawing**

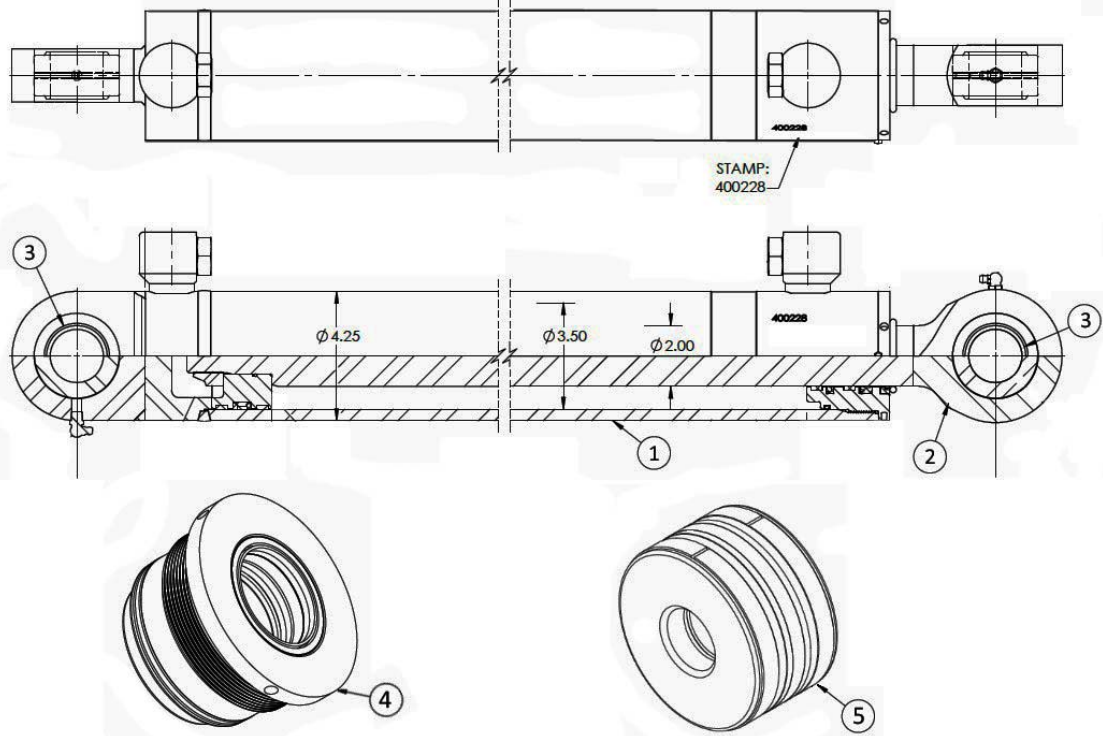

Seal Kit: 432022P

ITEM	PART	DESCRIPTION
1	201876P	Barrel
2	30154P	Rod
3	A125454-35	Bearing: spherical 1.75
4	500854P	Head: 3.50 X 2.00 IT
5	400698P	Piston: 3.50 X 1.13 CT

**Lift Cylinder - (400258)**

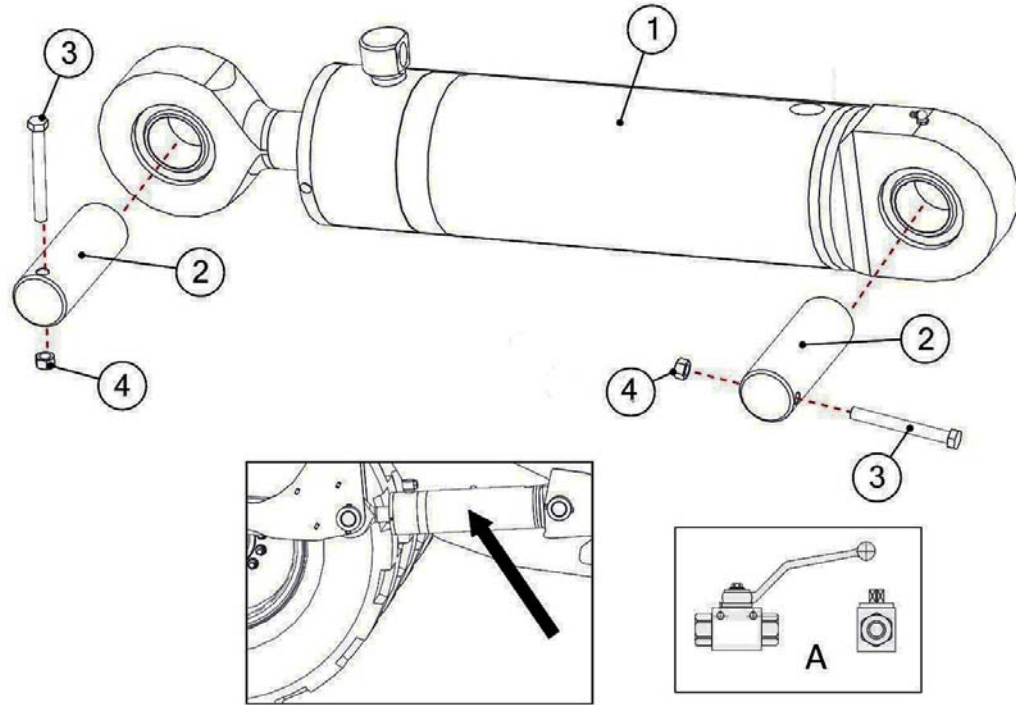

ITEM	PART	DESCRIPTION
1	400258	LIFT CYLINDER (6.5 x 15.88 x 2.5")
2	501862	Pin: 2 1/2 X 7"
3	AFB-00112	Bolt: 1/2 X 4 12 Gr 8 Hex Cap
4	AFN-00060	Nut: 1/2 Gr 8 Hex Cap
A	400220	Valve: Safety Shut Off Ball

**ASHLAND SCRAPERS**

**Lift Cylinder - (400258) - drawing**

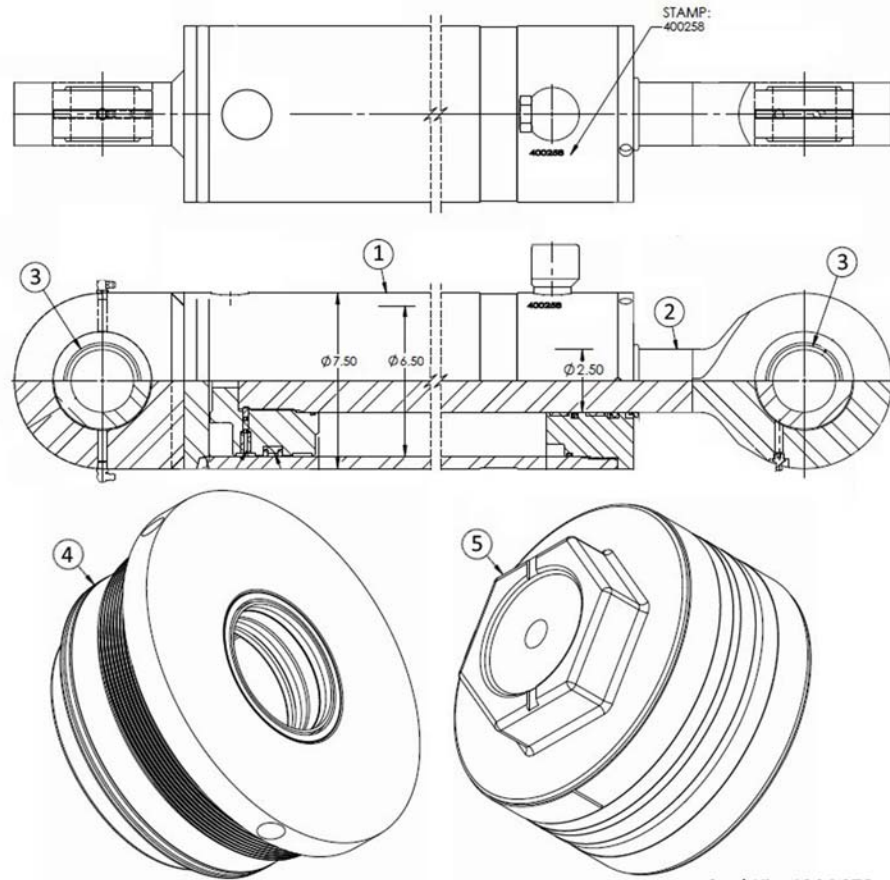

Seal Kit: 432067P

ITEM	PART	DESCRIPTION
1	201910P	Barrel
2	301580P	Rod
3	A125159-35	Bearing: Spherical 2.50
4	500870P	Head 6.50 X 2.50 IT
5	400714P	Piston: 6.50 X 2.38-12 UN CT

**Decals (2014CS)**

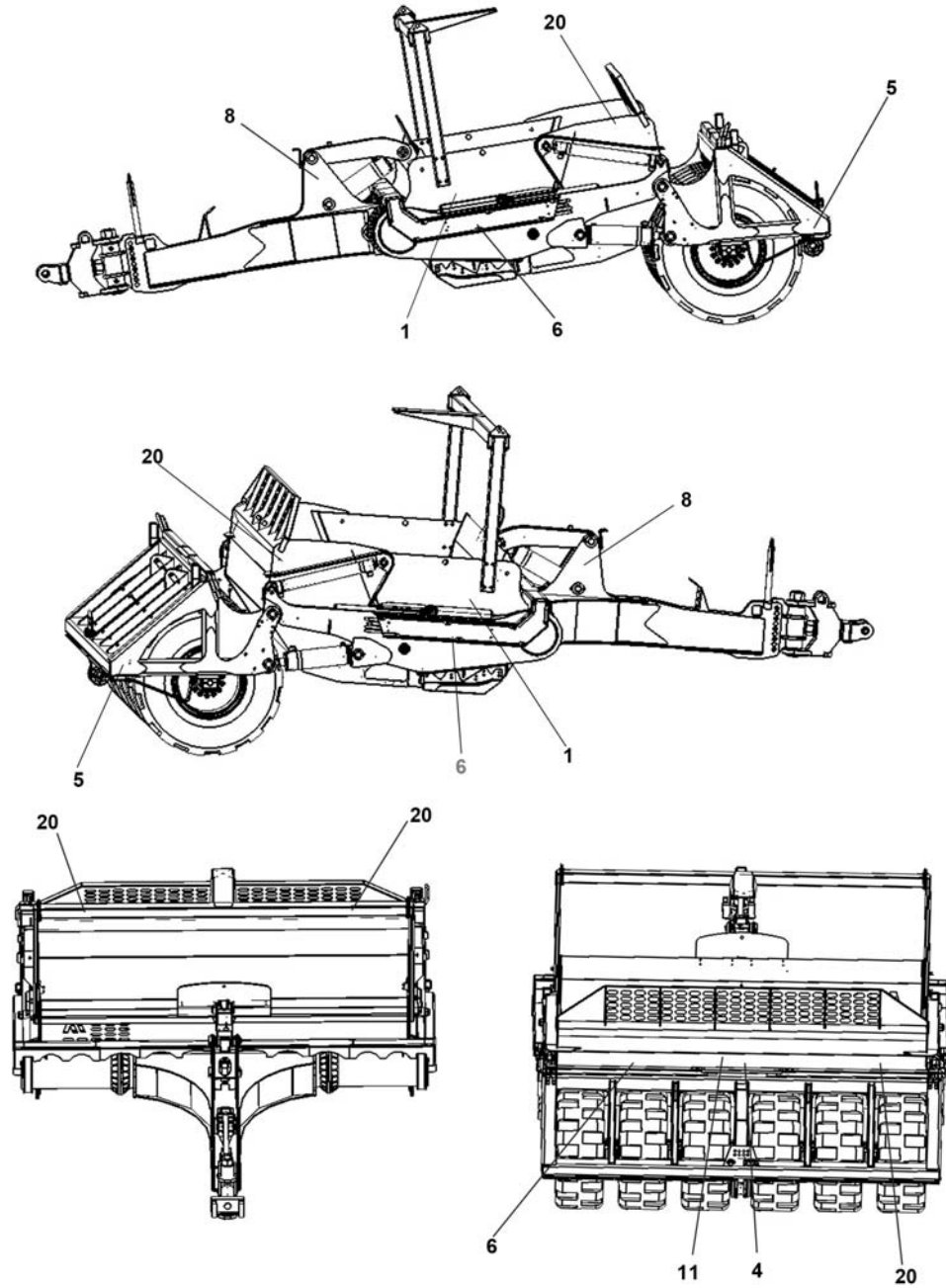

**Scraper Decals**

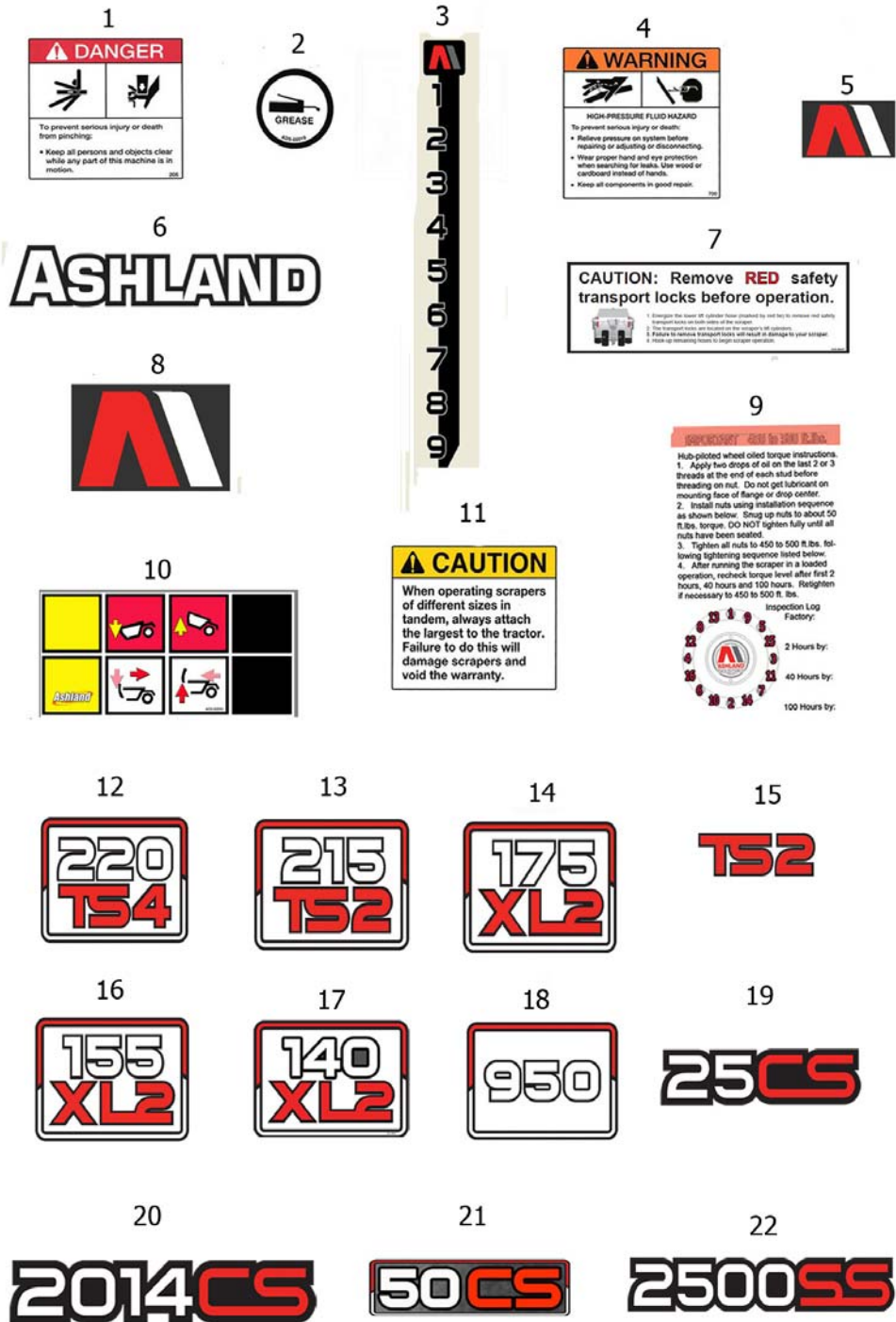

**ASHLAND SCRAPERS****Scraper Decals**

ITEM	PART	DESCRIPTION
1	ADS-00011	Pinch Point
2	ADS-00019	Grease Point
3	A123286	Depth Gauge
4	750464	High Pressure Fluid Hazard
5	ADS-00064	Small "Ashland"
6	ADS-00065	Large "Ashland"
7	ADS-00047	Transport Lock Advisory
8	ADS-00065	AI Logo Large
9	ADS-00054	Tighten Bolt Guide
10	ADS-00041	Plumbing Controls
11	ADS-00015	'Caution' Tandem Use
12	ADS-00060	Model 220TS4 Badge
13	ADS-00059	Model 215TS2 Badge
14	ADS-00058	Model 175XL2 Badge
15	ADS-00063	Model TS2 Badge Insert
16	ADS-00057	Model 155XL2 Badge
17	ADS-00067	Model 140XL2 Badge
18	ADS-00055	Model 950 Badge
19	ADS-00073	Model 25 CS Badge
20	ADS-00076	Mdel 2014 CS Badge
21	ADS-00070	Model 50 CS Badge
22	ADS-00072	Model 2500 SS Badge

**Hydraulic Manifold (A125211)**

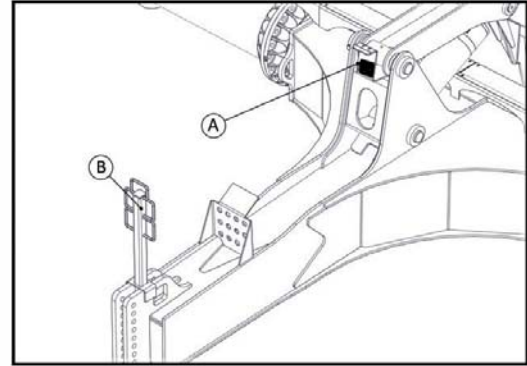
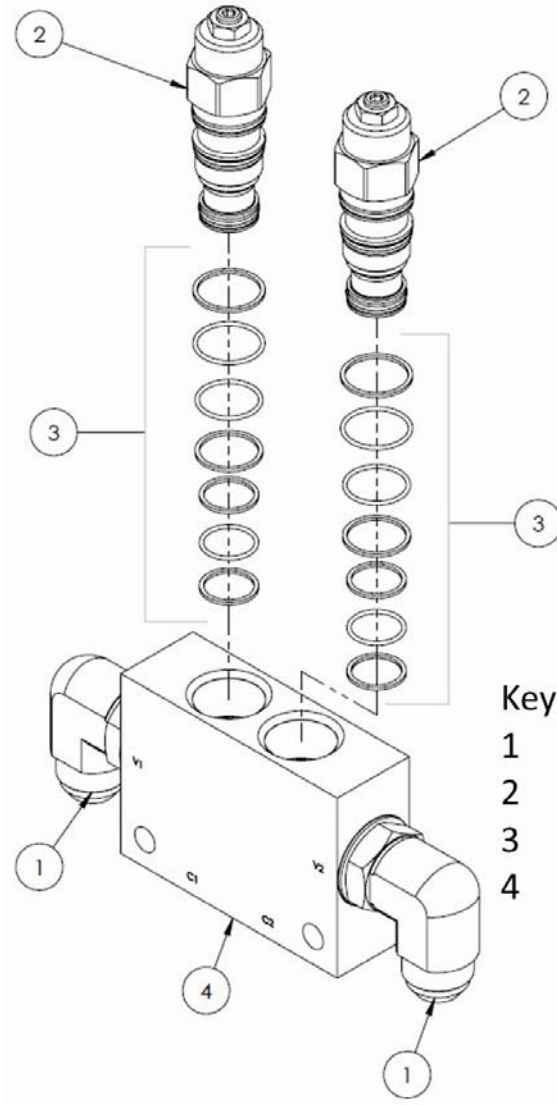

Key#	Part Number	Description
1	AHA-00044	#12 M-ORB x #12MJIC 90
2	A125211-01	Counterbalance Valve
3	A125211-01KIT	Seal Kit
4	A125211-02	Manifold

ITEM	PART	DESCRIPTION
A	A125211	Valve: Manifold Assembly, with Cartridges
B	600912	Hose Holder: Line Keeper



**ASHLAND SCRAPERS**

**Hydraulic Plumbing Clamps**

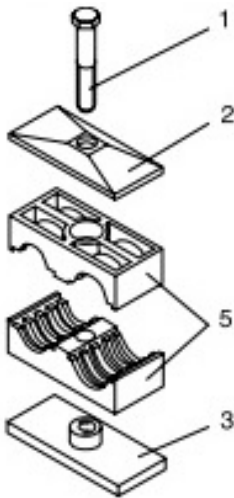

Twin Clamp with  
Weld Plate

AHL-00002

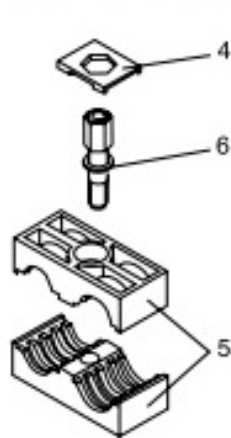

Twin Clamp  
Stacking Module

AHL-00022

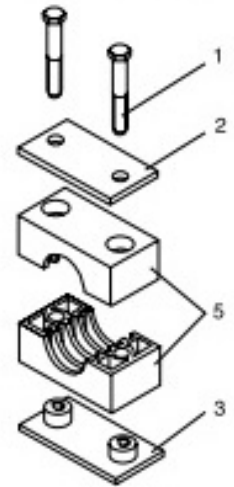

Single Clamp with  
Weld Plate

AHL-00001

Parts Legend	
1	Hex Head Bolt
2	Top Plate
3	Weld Plate
4	Safety Plate
5	Clamp Pair
6	Stacking Bolt

## Axle Service Recommendations

### Grease Maintenance

- 5 Pumps Every 50 Hours

- Inspect / Re-Pack Wheel Bearings after First Initial 300 hours of Operations

- Complete Cleaning and inspection every 2,000 hours

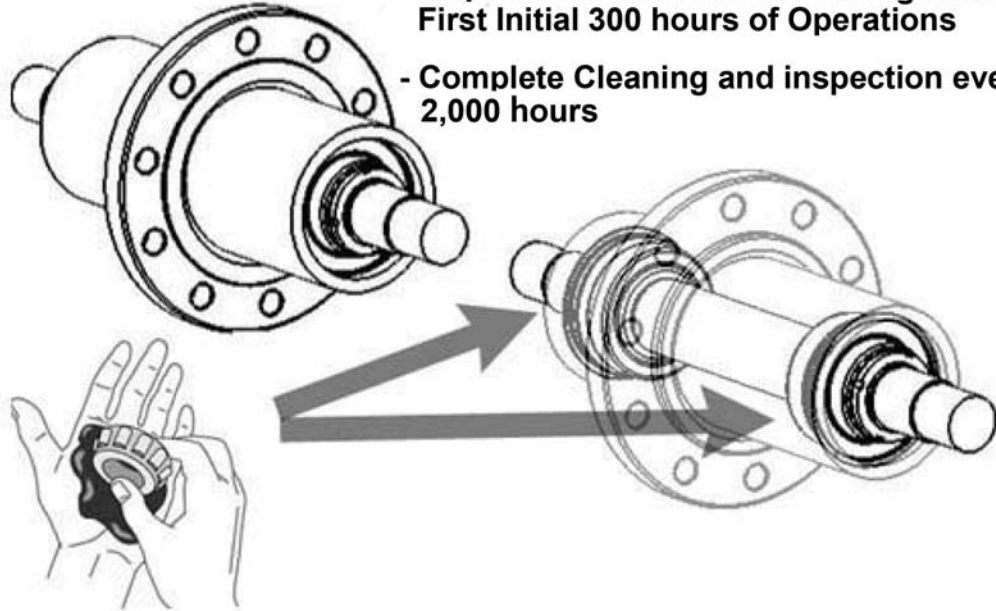

The bearings within the rear axle of the scraper are fully greased with a Mobilgrease XHP 222 series grease at the factory. This series of grease is an extended service lithium complex greases intended for a wide variety of applications and severe operating conditions. Ashland uses special bearing grease packer to ensure the bearing is effectively & evenly lubricated. Generous amounts of additional grease are added on both sides of the bearing prior to install within the hub.

Before installing or re-installing the hub, follow this procedure to ensure spindle machined surfaces are clean and undamaged.

1. Remove old lubricant and thoroughly clean spindle.
2. Inspect machined spindle seal surface for nicks, scratches, burrs or marks. If needed, use crocus cloth or emery cloth to repair damaged areas.
3. Clean spindle threads thoroughly with a wire brush to avoid false bearing adjustments and to avoid introduction of contaminants into the hub.
4. Thoroughly clean spindle machined surfaces of rust, dirt, grease or other contaminants that could damage the hub seal and cause it to leak.

**ASHLAND SCRAPERS****Axle Service Recommendations****Mobilgrease XHP™ 222**

Mobilgrease XHP 222, part of the Mobilgrease XHP™ 220 series, is an extended service lithium complex greases intended for a wide variety of applications and severe operating conditions. These greases were designed to outperform conventional products by applying cutting edge, proprietary, lithium complex manufacturing technology. They are formulated to provide excellent high temperature performance with superb adhesion, structural stability and resistance to water contamination. These greases have a high level of chemical stability and offer excellent protection against rust and corrosion. These greases feature high dropping points and maximum recommended operating temperature of 140° C (284°F).

**Caution**

Too much grease volume (overgreasing) in a bearing cavity will cause the rotating bearing elements to begin churning the grease, pushing it out of the way, resulting an increase of bearing component temperatures. This leads to rapid oxidation (chemical degradation) of the grease as well as an accelerated rate of oil bleed, which is a separation of the oil from the thickener. The heat that has been generated over time along with the oil bleed eventually will cook the grease thickener into a hard, crusty build-up that can impair proper lubrication and even block new grease from reaching the core of the bearing. This can result in accelerated wear of the rolling elements and then component failure.

## Grease Locations CS

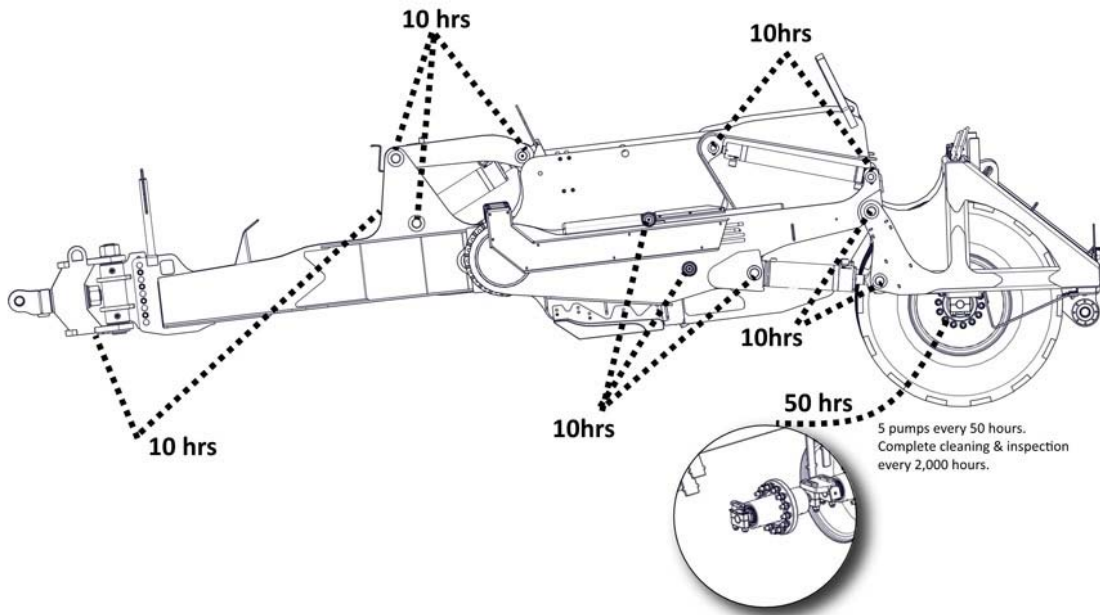

### Lubrication Points (see Ill.)

1. Hitch – Horizontal and vertical pins.
2. Lift Cylinders – Rod end & Base End; Both left & right sides.
3. Front Arm Pivot Joint – Both left & right sides.
4. Apron Cylinders – Rod clevis pin; Both left & right sides.
5. Apron Pivot Pin – Both left & right sides.
6. Hold-down Rollers – Both left & right sides.
7. Floor Rollers – Both left & right sides.
8. Tapered Rollers – Both left & right sides.
9. Hubs

**ASHLAND SCRAPERS****Hub-Axle Assembly**

1. Lubricate bearings cones (item 7,X2).
2. Install (1) bearing cones onto axle.
3. Install new o-rings (item 3, x2) onto axle.
4. Install bearing spacer against lubricated bearing.
5. Install (1) lockwasher against bearing spacer with internal tab positioned in keyway of axle.
6. Install (1) locknut. Torque to 50 ft-lb. Bend appropriate lockwasher tab into locknut slot.
7. Install axle assembly into hub from "fixed" end.
8. Repeat steps 2-5 for parts on "pre-load" end of hub.
9. Install locknut and torque as follows:
  - Initial torque locknut to 200 ft-lb.
  - Back off locknut one full turn.
  - Rotate axle at least 5 revolutions.
  - Torque locknut to 50 ft-lb while rotating axle.
  - Back off locknut 1/4-1/2 turn.
  - Final torque locknut to 55-65 in-lb.
10. Bend appropriate lockwasher tab into locknut slot.
11. Lubricate seals and install into hub.
12. Install retaining rings (item 8,x2).

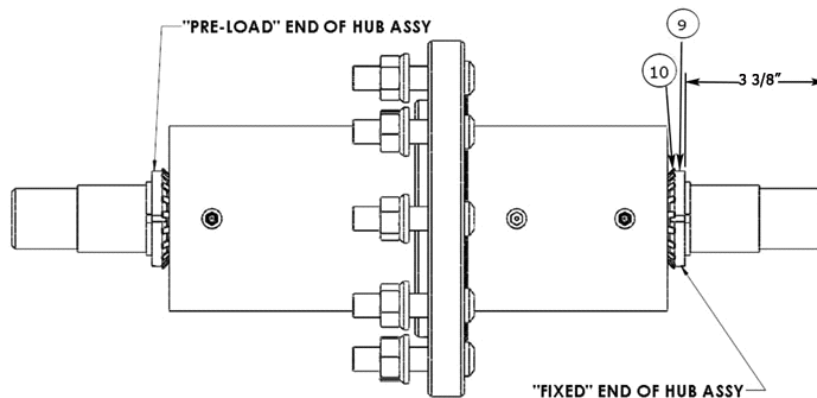

**ASHLAND SCRAPERS****Hub-Axle Disassembly**

1. Disengage lock tab on "pre-load" side of axle lockwasher (item 10).
2. Remove axle locknut (item 9) and lockwasher (item 10).
3. Remove seal retaining rings (item 8, x2).
4. Remove hub seals (item 5, x2).
5. Remove axle (item 2) out "fixed" end of hub.
6. Remove bearing spacers (item 4, x2).
7. Remove bearing cones (item 7, x2).
8. Remove o-rings from axle (item 3, x2).

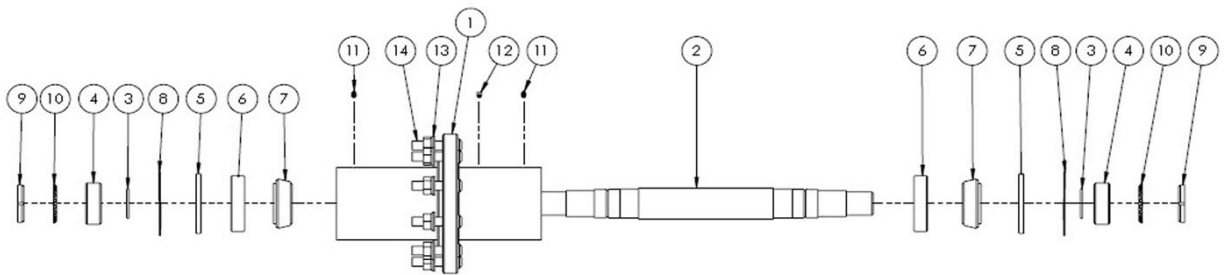

**ASHLAND SCRAPERS**
**Tire Inflation**

**TIRE INFLATION & TORQUE CHARTS**

TIRE INFLATION (PSI)				
Scraper Model	Front Tire Size (XL)	Max PSI	Rear Tire Size	Max PSI
25			11L-15 8 Ply	35
50			16.5L-16.1 10 Ply	36
950	16.5L-16.1 10 Ply	36	16.9-24 8 Ply	35
140	550/45-22.5 16 Ply	41	18.4-26 18 ply	46
140 LGP	550/45-22.5 16 Ply	41	23.5-25 20 Ply	44
155	20.5-25 12 Ply	38	29.5-25 28 Ply	62
175	20.5-25 12 Ply	38	29.5-25 28 Ply	62
175 (Big Tire)	23.5-25 20 Ply	44	29.5-25 28 Ply	62
215			20.5-25 20 Ply	65
220			20.5-25 20 Ply	65
2014			20.5-25 20 Ply	65

**On new machines, the wheels should be retorqued after the first two hours of use.** Then check tires daily to ensure correct inflation levels. Check tire pressure with an accurate gauge having 6.9 kPa (0.07 bar) 1 psi gradations. Check tires daily to ensure correct inflation levels. Also check for:

- Tire Damage
- Loose or missing wheel lugs, nuts or caps
- Uneven wear
- Damaged Rims

**Standard Torque Chart:**

Torque Ft-lbs	Bolt Diameter
12	1/4"
25	5/16"
45	3/8"
70	7/16"
110	1/2"
150	9/16"
220	5/8"
380	3/4"
600	7/8"

**ASHLAND SCRAPERS****Maintenance Check List**

1. Grease all zerks.
  - a) Every 8 hours of operation.
  - b) See Lubrication Points section on next page.
  
2. Greasing the hubs.
  - a) Re-pack wheel bearings after 300 hrs of operation.
  - b) Completely clean grease out of hub and bearings every 1200 hours of operation.
  
3. Check tire pressure.
  - a) See Tire Pressure Chart.
  
4. Check all pins for signs of wear.
  - a) Daily
  
5. Check wheel lug nut torque.
  - a) After first 2 hours of operation.
  - b) Recheck daily for next 2 weeks.
  - c) Tighten wheel lug nuts in a star pattern.
  - d) Torque wheel lug nuts (See Torque Specifications).
  
6. Check and retighten all bolts.
  - a) After initial 10 hours of use.
  - b) Again after 50 hours of use.
  - c) See Torque Specifications.
  
7. Inspect cutting edges.
  - a) Daily
  - b) Replace cutting edges when center blade has been worn to approximately 6" and side edges worn to approximately 4".



**CAUTION!** Failure to replace worn cutting edges may result in unnecessary wear to the earthmover sides and floor.

Note: Please specify left or right "L" shaped cutting edges when ordering replacements. Left or right side parts are determined by viewing from rear of the scraper.



**ASHLAND SCRAPERS****Service: Tire Service**

**The task of servicing tires and wheels can be extremely dangerous and should be performed by trained personnel only, using the correct tools and following specific procedures. Do not attempt to mount, demount or inflate a tire if you do not have the proper equipment and experience to perform the job. Call a qualified repair service to inspect the assembly and make necessary repairs. Failure to heed warnings could lead to serious injury or death.**

Visually inspect tires and wheels daily. Carefully inspect any rim and tire assembly that has been run underinflated or flat before reinflating the tire to make sure there is no damage to either the rim or tire.

- ALWAYS wear personal protection equipment such as gloves, footwear, eye protection, hearing protection and head gear when servicing tire and wheel components.
- DO NOT operate with damaged rims, tire cuts or bubbles, missing lug bolts or nuts or damaged rims.
- ALWAYS maintain the correct tire pressure. NEVER exceed recommended tire inflation pressure.
- INSPECT any rim and tire assembly that has been run flat or severely underinflated before reinflating the tire. Damage to the rim and tire may have developed.
- NEVER inflate a tire that has lost air pressure or has been run flat without determining and correcting the problem.
- NEVER try to repair wheel, rim, or tire components parts. Parts that are cracked, worn, pitted with corrosion, or damaged must be discarded, and replaced with good parts.
- ALWAYS use approved tire and rim combinations for the model scraper that you have and verify that part numbers of components are correctly matched for the assembly.
- ALWAYS exhaust all air from the tire prior to demounting.
- ALWAYS place wheel and tire assemblies in restraining devices (safety cage) when inflating tires. Use a clip-on chuck and long extension hose to allow you to stand to the side of the tire and not in front of it.
- NEVER weld or cut on an inflated tire assembly. Welding heat can cause increased pressure which could result in tire explosion.
- ALWAYS use proper lifting techniques, and mechanized lifting aids to move heavy components and assemblies.
- NEVER leave a tire, wheel, or assembly unsecured in a vertical position.
- ALWAYS take care when moving tires and wheels that other people in the area are not endangered.

**ASHLAND SCRAPERS****Troubleshooting**

With proper care and maintenance, your Ashland Scraper will give many years of reliable service. When a situation arises where the earthmover performance is not satisfactory, this section will give some pointers on finding and correcting the problem.

---

**Grease zerk will not take grease.**

---

1. Grease zerk plugged.
  - a) Remove and replace grease zerk.
2. Pin is frozen.
  - a) Remove, clean, and inspect pin.
  - b) Replace pin if necessary.
3. Bushing grease passage is not aligned with grease zerk.
  - a) Remove, clean, inspect, and realign bushing.
  - b) Replace bushing if necessary and realign.

---

**Push-off rollers do not roll.**

---

1. The rollers need lubrication.
  - a) Check zerk hole and grease.
  - b) Remove pin, clean, inspect, and replace if necessary.
2. The roller bushing is worn out.
  - a) Remove roller assembly and replace bushing.
  - b) See parts manual.

---

**Cylinders will not hold in preset position, i.e. the cylinder creeps.**

---

1. Seals leaking internally.
  - a) Remove and replace seal kit.

---

**Machine cuts unevenly.**

---

1. Cutting edges worn unevenly.
  - a) Replace cutting edges.
2. Improperly inflated tires.
  - a) Check air pressure in tires.

## ASHLAND SCRAPERS

# Warranty Statement

### The Purpose of Warranty

Ashland Industries warrants each new product to be free from defects in material and workmanship. This warranty is applicable only for the normal service life expectancy of the product or components, not to exceed one year from the date of delivery of the new Ashland Industries product to the original purchaser, or the date the product is first put into service via a rental agreement or other means, whichever occurs first.

### Dealer Responsibilities

The following responsibilities are to be performed when the dealer delivers a product to the purchaser or otherwise places it into warranty service:

Complete the Warranty Registration Form and forward it to Ashland Industries within 30 days of the sale, rental or other use of the product. Warranty reimbursement is contingent upon product registration.

Review the warranty statement and operator's manual with purchaser to assure understanding of purchaser's responsibilities as related to warranty, service, and the proper and safe operation of the product. Purchasers/Renters should be advised to have failed parts repaired or replaced immediately upon failure, as continued use will result in additional damage, excessive wear, and may result in personal injury.

Contact Ashland Industries prior to beginning repair or replacement of failed parts to make certain that the cost of repairs are consistent with the value of the product being sold.

Warranty requests for units in dealer's inventory may be submitted to Ashland Industries when defects are noted in products prior to the retail sale or rental of that unit.

Provide warranty and service repairs as directed by Ashland Industries' "Service Repairs Bulletins" or other instructions.

All warranty work must be completed within 30 days of failure. Notify Ashland Industries' warranty department if repairs will require more than 30 days after failure for an extension. No claim will be accepted for warranties that exceed this 30 day period.

No warranty will be allowed on units delivered to the retail customer prior to the full payment of that unit to the manufacturer by the dealer.

If diagnostic time is required, contact Ashland Industries Inc. prior to beginning the warranty repair for approval. Ashland Industries must approve travel time reimbursement prior to beginning the warranty repair.

### Ashland Industries Responsibilities

Reimbursement for parts used in warranty repair will be credited only when the parts are purchased from Ashland Industries Inc. Parts will be credited at dealer's net cost. No warranty will be allowed on parts that are past due.

Dealer should use parts from their parts inventory first. In the event that parts must be shipped from Ashland Industries Inc., freight will be paid by Ashland Industries and will be shipped by the most economical means to arrive in the shortest possible time. Air, Next Day Air, Priority and other special shipment methods requested by the dealer will be at the customer's expense.

Warranty Labor Reimbursement for labor expense to the dealer is made by payment of the established hourly shop rate.

Repair times will be reviewed by Ashland Industries Inc. and may be adjusted to average repair time required by other dealers to make similar repairs. Labor is not paid on the warranty associated with repair parts purchased by the retail customer that are used on a product that is not currently in warranty time frame.

Reimbursements for repairs made by an outside source (not dealer personnel) will be made for those services deemed necessary for the resolution of the warranty by Ashland Industries' warranty department.

Outside repair invoices must have prior approval from Ashland Industries' service department and must be attached to the warranty claim after approval.

**ASHLAND SCRAPERS****Warranty Statement****Other Warranty Provisions**

The following guidelines are to be followed when performing warranty repairs:

In all cases, the most economical repair should be performed unless otherwise directed. Credit will not be allowed for assemblies or groups if it is practical to make the repair with individual parts. In some cases, the assembly or group price may be less than the total of the parts and labor required to complete the repair. In those cases, an assembly or group may be used.

Only those parts provided by Ashland Industries are covered under Warranty. The use of parts from other sources will not be eligible for warranty consideration.

All parts removed during warranty repair should be held for a period of 90 days after the warranty claim has been submitted to Ashland Industries Inc. These parts can be discarded if disposition or return request hasn't been made during this period. Parts that are requested must be returned within 30 days of claim disposition. These parts will be discarded after the 30 day period.

Ashland Industries Inc. reserves the right to deny or reverse any and all warranty claims for parts, labor or miscellaneous charges when errors are found, warranty provisions are abused, or fraudulent claims are submitted.

**Warranty Reimbursement is Not Possible**

When failure falls under the "limitations" as identified in Ashland's Limited Warranty Statement.

When Ashland Industries has requested the return of certain parts, assemblies or information and has not received the material with 30 days of date posted on return request.

On claims due to damage or shortage that are obviously the responsibility of dealer or the delivering carrier.

On the entire claim when warranty policy and provisions are not followed.

*All dealers will warranty their technician's work to the purchaser and will indemnify Ashland Industries Inc. from such claims.*

**Service Bulletins**

Service Bulletins will be issued when necessary to alert dealers of special repairs. Each bulletin will give detailed directions and procedures to complete the service.

**Procedures For Completion Of Warranty Form**

Complete the warranty form available at [www.ashlandind.com](http://www.ashlandind.com) or in your dealer's yellow Ashland Sales Book. Return this form to Ashland Industries within 30 days of failure.

**Use of Photos**

Pictures of the failure are recommended but not required. Photos should be attached to dealer's claim when their inclusion will help identify the condition of the part being repaired or replaced, and thus assisting in approval of the claim. In many cases, the use of photos may eliminate the need to return parts for evaluation. Photos will not be returned unless specifically requested. Digital photography will also be acceptable and can either be mailed or email to [warranty@ashlandind.com](mailto:warranty@ashlandind.com)

**Delayed Warranty Repairs**

Warranty repairs should be scheduled and performed as soon as possible after notifying dealer and Ashland Industries. There may be circumstances that require the use of the product for a short period of time by the retail customer, or the availability of repair parts may require the work to extend past a 30 day period. In these cases, the dealer must notify Ashland Industries in writing of the extenuating circumstance and advise that the continued use of the product will not enlarge the warranty claim. These claims will then be processed as if the product is still within the warranty period.

**Denied Claim**

Dealers will be notified of a denied claim in writing, and notification will state the reason for denial. A dealer has the right to appeal this claim and must do so within 30 days of notification of denial. If there has been no appeal within the 30 day period, the claim will be considered closed.

**ASHLAND SCRAPERS****Warranty Statement****Limited Warranty Statement**

Ashland Industries Inc. warrants each new product to be free from defects in material and workmanship. This warranty is applicable for products or components, not to exceed one year from the date of delivery of the new Ashland Industries product to the original purchaser, or the date the product is first put into service via a rental agreement or other means, whichever occurs first.

The major components of swivel hitches used on Industrial series scrapers are warranted for three consecutive months from the date of delivery of the new Ashland Industries product to the purchaser, or the date the product is first put into service via a rental agreement or other means, whichever occurs first, except those components described below.

Genuine Ashland Industries Inc. replacement parts and components will be warranted for 30 days from date of purchase, or the remainder of the original equipment warranty period, whichever is longer.

Under no circumstances will it cover any merchandise or components thereof, which in the opinion of the company, has been subjected to misuse, unauthorized modification, alterations, an accident or if repairs have been made with parts other than those obtained through Ashland Industries Inc.

Ashland Industries Inc. in no way warrants tires since their respective manufacturer warrants these items separately. Please call Ashland Industries Inc. to receive phone numbers of tire suppliers.

Ashland Industries Inc. in no way warrants wearable items such as cutting edges, front dolly wheel balls, socket halves, rollers, bushings, yoke hitch pins, hitch bushings, etc.

Our obligation under this warranty shall be limited to repairing or replacing, free of charge to the original purchaser, any part that, in our judgement, shall show evidence of such defect, provided further that such part shall be returned within 30 days from the date of failure to Ashland Industries Inc. routed through the dealer and distributor from whom the purchase was made, transportation charges prepaid. Upon warranty approval proper credits will be reimbursed for transportation.

This warranty shall not be interpreted to render Ashland Industries Inc. liable for injury or damages of any kind or nature to person or property. This warranty does not extend to the loss revenue, extra labor cost associated with downtime, substitute machinery, rental or for any other reason.

Except as set forth above, Ashland Industries Inc. Shall have no obligation or liability of any kind on account of any of its equipment and shall not be liable for special or consequential damages. Ashland Industries Inc. make no other warranty, expressed or implied, and, specifically, Ashland Industries Inc. disclaims any implied warrant or merchantability or fitness for a particular purpose. Some states or provinces do not permit limitations or exclusions of implied warranties or incidental or consequential damages, so the limitations or exclusion in this warranty may not apply.

This warranty is subject to any existing conditions of supply which may directly affect our ability to obtain materials or manufacture replacement parts.

Ashland Industries Inc. reserves the right to make improvements in design or changes in specifications at any time, without incurring any obligation to owners of units previously sold. No one is authorized to alter, modify or enlarge this warranty nor the exclusion, limitations and reservations.

**Owner Registration**

Be sure to complete the Owner Registration form that you received with your machine and return it to Ashland Industries within 30 days of the sale, rental or other use of your product. Warranty reimbursement is contingent upon product registration. If your product is not registered, it is NOT covered under warranty.