

ASHLAND INDUSTRIES

Parts Manual

I-130XL2

09-15



Ashland Industries

Crafting Quality since 1953!



1115 Rail Drive
P.O. Box 717
Ashland, WI U.S.A.
Toll Free: (877) 634-4622
Business: (715) 682-4622
Fax: (715) 682-9717

www.ashlandind.com
www.scaperdrawbar.com

Table of Contents

Alphabetized Listing

A		XL Assembly	6
	Apron Assembly (130-1020)	8	
	Apron Cylinder (#A125050) 4" X 13"	17	
	ASHLAND SCRAPERS	1-35	
	Assembly - Push Off (110-130)	11	
	Assembly - Wheel Front (130)	14	
	Assembly - Wheel Rear (130X) Optional	16	
B			
	Bowl & Frame Assembly	9	
G			
	Gooseneck Frame Assembly (130)	7	
H			
	Hydraulic Hoses (I-130XL2)	25	
	Hydraulic Hoses (I-130XL2) Illustration	26	
	Hydraulic Manifold (#A125174)	20	
	Hydraulic Plumbing Front (I-110-130)	23	
	Hydraulic Plumbing Rear (I-110-130)	24	
	Hydraulic Schematic: I-130XL2	27	
	Hydraulic Valve Ports Assembly	21	
	Hydraulic Valve Seals	22	
I			
	Introduction	1	
L			
	Lift Cylinder (#A516H114) 5" X 16"	18	
	Lubrication Points	32	
M			
	Maintenance Check list	31	
O			
	Operation and Maintenance	2	
P			
	Pole & Axle Assembly (130)	13	
	Push Off Cylinder (400045) 4 1/2 X 54"	19	
	Pushing the Earthmover	33	
R			
	Rear Wheel Assembly (110X-130X)	15	
S			
	Safety Guidelines	5	
	Scraper Specifications I-130XL	30	
T			
	Tire Inflation & Torque Charts	28	
	Tire Warning	29	
	Troubleshooting	34	
W			
	Warranty Statement	35	
X			

ASHLAND SCRAPERS

Introduction

Thank you for choosing an Ashland scraper for your earthmoving needs. Years of research, testing and successful application have been spent to ensure quality and maximum performance for our customers.

QUALITY POLICY

It is our mission to exceed our customers' expectations in quality, delivery, and cost through continuous improvement and customer interaction.

Please read and understand this manual before attempting to attach or operate this scraper. This manual should always remain with the machine. Be sure and fill out and send in the owners registration form at the beginning of this manual, or you may fill out the form on-line by going to ashlandind.com and click on "Register your Machine" at the bottom of the page. If you have questions, please feel free to call or email us. You can visit us on-line at www.ashlandind.com.

Ashland Industries hours of operation are 8:00 a.m. to 5:00 p.m. CST. We can be reached toll free at: 877-634-4622.

SCRAPER ID NUMBER

The serial number plate for the scraper is located on the right rear area of the scraper. The letter and numbers stamped identify the serial number, model number and capacity of the scraper. Please record this serial number for use in ordering parts, warrantee issues and to track your equipment if it is ever stolen.

References to serial number breaks on parts are located in the manual with a reference sequence of XXXXX-XXXXX. The beginning number records the serial number start of the use of that part. The ending number is the final serial number use of the part within this machine.



IMPORTANT

Parts must be ordered through your local authorized ASHLAND dealer. Be sure to state MODEL and SERIAL NUMBER of your machine. Ashland Industries weldable replacement parts are also available to rebuild, modify or update your scraper to current factory specifications.

ASHLAND SCRAPERS

Operation and Maintenance

Your Ashland scraper is a durable piece of equipment and with proper care will yield many years of trouble free operation. However, the life of your scraper can be severely shortened by poor maintenance. You must follow consistent maintenance practices and use good quality grease and hydraulic oil (compatible with the power unit's hydraulic system) to insure the longer, most productive use from your scraper.

Your scraper should be greased at all points where grease fittings are provided. **REMOVE TRANSPORT LOCKS** prior to operation. Next, extend and retract all cylinders several times to force out any air from the hydraulic cylinders and lines. Check the oil levels in the tractor hydraulic system and add to maintain the proper level. Care should be used when adding oil or when disconnecting any oil line to keep all dirt out of the oil as dirt is a major factor in the failure of hydraulic components.

When your scraper is placed into operation, the operator will have to "feel out" the amount of depth of cut to obtain maximum loading efficiency. This is usually accomplished by taking a lesser and more uniform cut; however, some soil conditions such as loose sand may require a "pumping action" obtained by taking successive deep cuts and lifting out of cut as the tractor begins to lose power or traction.

- After 8 hours of operation, all bolts should be checked and tightened if necessary and all grease fittings lubricated. Check tire pressures daily. Also, check pins and cutting edges for signs of wear.
- After 50 hours work, all bolts should be rechecked and tightened if necessary. Check wheel bearings and adjust if necessary.
- Check wheel lug nut torque.
 - After first 2 hours of operation.
 - Recheck daily for the next 2 weeks.
 - Tighten wheel lug nuts in a star pattern.
 - Torque wheel lug nut (see Torque Specifications).
- After 300 hours work, clean and repack wheel bearings and replace, if necessary, cutting edges, worn pins, etc.



Failure to replace worn cutting edges may result in unnecessary wear to the earthmover sides and floor.

ASHLAND SCRAPERS

Operation and Maintenance

Before starting a job, make sure Diggers Hot Line has been contacted and all underground utilities have been properly located (electric, phone and pipelines). Have a clear understanding of all local, OSHA and MSHA rules that apply to the job. Beware of your environment and keep others a safe distance from the machine while familiarizing yourself with the machine's controls. The scraper requires a power source with **TWO** 4-way (double acting) hydraulic control valves.



Scraper damage can occur if:

1. The scraper is running over the haul road with the bowl fully raised.
2. A power unit that is above the horsepower rating is pulling the scraper.
3. The scraper is being used to level haul roads with the apron closed.
4. The scraper is being top loaded with the bowl in a raised position.
5. The scraper is being used to load rock.

These types of damage are not covered by warranty. Warranty only covers defects in material or workmanship and not abuse because of improper use.

Know the job:

1. Know the weight of the material to be moved.
2. Lay the job out to take advantage of grades when loading, if possible.
3. Keep hauls as short as possible.
4. Keep haul roads smooth.
5. If more than one unit is on the job, make sure the haul roads are one way and that the operators understand the direction.
6. Brief the operators as to what the job consists of so there is not misunderstanding.
7. Know the moisture content in the material to be moved.
8. Will water be needed for proper compaction?
9. Will drainage be a problem?
10. How many units will be needed to efficiently complete the job?

Transport the scraper safely:

1. Always empty scraper.
2. Clean all material from exterior of scraper.
3. Make sure all road rules are followed.
4. Use proper lighting and flagging.
5. Lower scraper bowls to provide just enough clearance over obstacles.
6. Transport at a safe speed to avoid roll over.
7. Reduce speed on curves and when going downhill.

ASHLAND SCRAPERS

Operation and Maintenance

Apron Opening Guidelines:

You will need to determine the ideal opening for your soil condition. It is important to have the apron opened prior to loading. To receive the highest production possible, it is important to know the general characteristics of the material that you will be loading. In heavier soils like clay or gumbo, the soil will slab up and remain together after being cut by the blades. In lighter soils, like sand or dry loose top soil, the material will pile up or push after being cut by the blade. Use the suggestions listed below:

Topsoil with heavy vegetation (12" to 24" opening):

When cutting undisturbed soils, you will need to open the apron high enough to allow debris to easily enter the scraper bowl. If the apron is opened too high, the rolling up sod will fall out past the apron and hinder the incoming material. If the apron is not adjusted quick enough, the material will bunch or push ahead of the machine. If this happens, you should close the apron and pull out the cut quickly. If you wait too long, you may develop too large a pile to clear the scraper while rising out of the cut. This can cause the power unit to lose traction and possibly cause you to get stuck.

Clay or loamy material: (6" to 12" opening):

To cut clay or loam soils, lower the apron to approximately 6" to 12" between the blades and the bottom of the apron. When you first lower the bowl, you'll see the material being cut by the blades and entering the bowl. As you continue to move forward, small clumps will fall past the apron and develop a small pile ahead of the apron. By limiting this apron opening, the small pile will "blade off" any loose material ahead of the machine. Adjustments should be made if large objects such as rocks or deep gouges are within the cut.

Sand or loose topsoil (15" to 30" topsoil):

Loading sand or loose top soil is the most difficult type of soil to load. In combination with the larger apron opening, you'll want to operate at a faster ground speed. By traveling faster and lowering the blade deeper than normal, it forces the material into the scraper bowl.

We encourage you to experiment with different apron openings to determine the best condition for your jobsite.



The Apron is designed to capture material inside of the scraper bowl and should not be used as a large blade. Obstructions like large rocks or dense piles may cause the apron to bend inward after prolonged exposure to these conditions.

ASHLAND SCRAPERS**Safety Guidelines****SAFETY GUIDELINES**

SAFETY SIGNAL WORDS: Please note the use of signal words such as DANGER, WARNING, and CAUTION paired with the safety messages on your scraper. The appropriate signal word for each safety message has been selected using the following guidelines:

- **DANGER:** Indicates an imminently hazardous situation that, if not avoided, will result in death or serious injury. This signal word is limited to the most extreme situations—typically for machine components which, for functional purposes, cannot be guarded.
- **WARNING:** Indicates a potentially hazardous situation that, if not avoided, could result in death or serious injury. For example, hazards that are exposed when guards are removed. This signal word may also be used to alert against unsafe practices.
- **CAUTION:** Indicates a potentially hazardous situation that, if not avoided, may result in minor or moderate injury. This signal word may also be used to alert against unsafe practices.

Operator safety is a main concern in designing and developing equipment. Designers and manufacturers include as many safety features as possible. However, every year many accidents occur which could have been avoided by extra thought and a more careful approach to handling equipment. The operator can avoid many accidents by observing the precautions in this section. To avoid personal injury, study the following precautions and insist those working with, or for you, follow them.

Replace any CAUTION, WARNING, DANGER or instruction safety decal that is not readable or missing. Locations of decals are indicated in this booklet.

Do not attempt to operate this equipment under the influence of drugs or alcohol.

Review the safety instructions in the operator's manual with all users annually.

Operators should be responsible adults who are familiar with machinery and trained in the equipment's operations. Do not allow persons to operate or assemble this unit until they have read this manual and the owner's manual and have developed a thorough understanding of the safety precautions and scraper operation.

ASHLAND SCRAPERS

XL Assembly

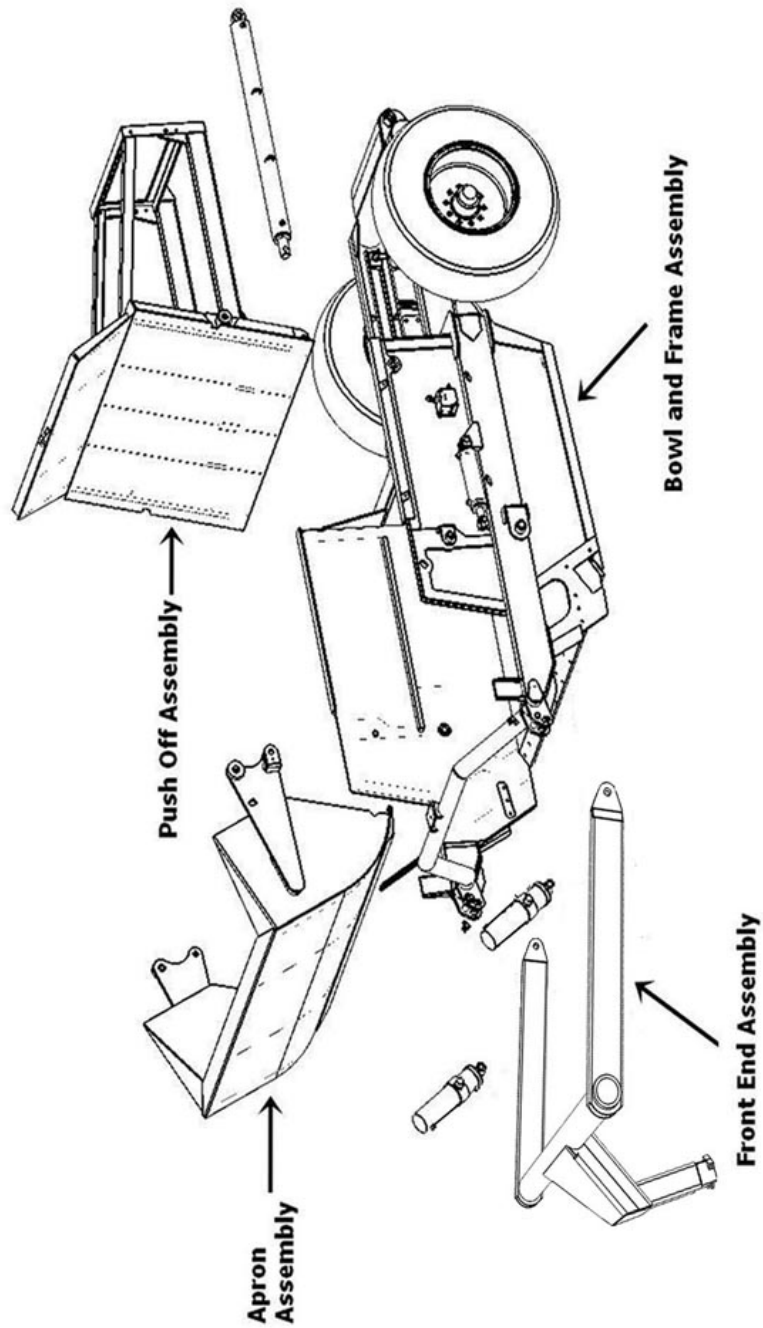

SXL300A001

ASHLAND SCRAPERS

Gooseneck Frame Assembly (130)

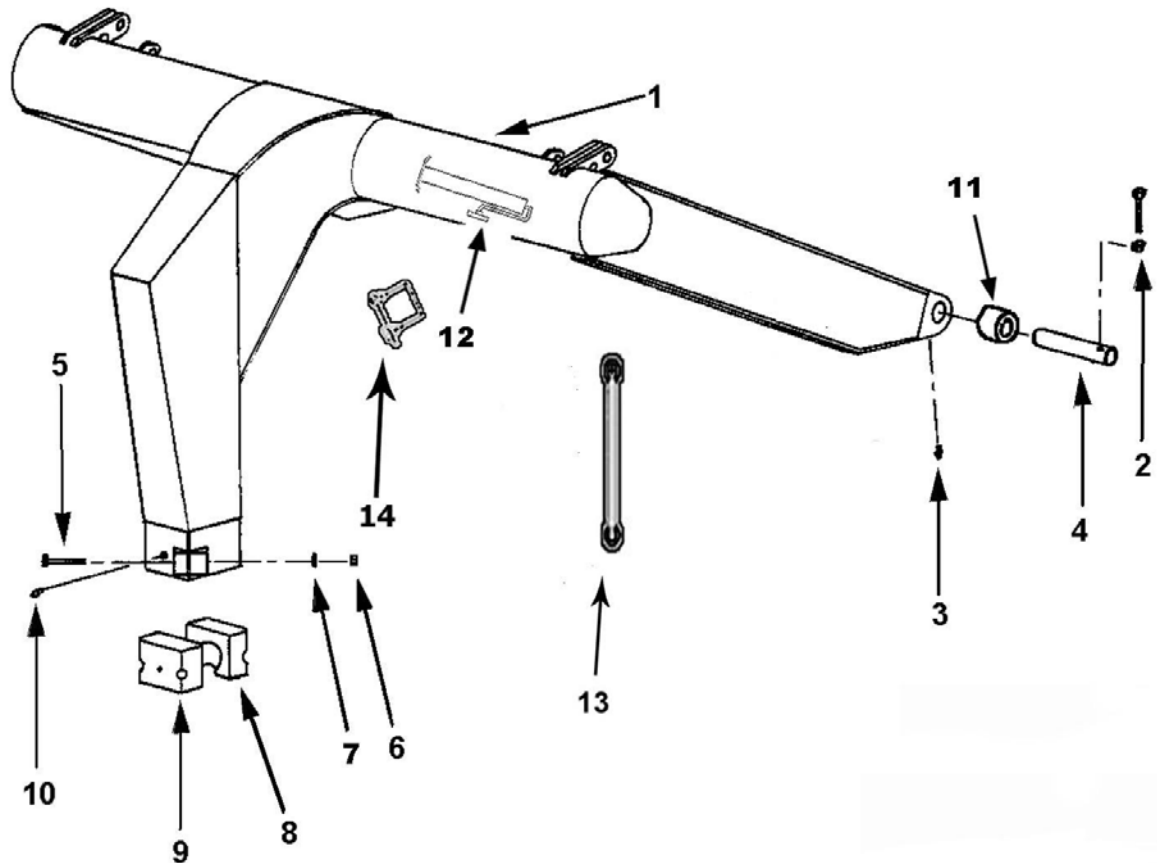

SXL300A003

KEY	PART	DESCRIPTION
1	A13011	Gooseneck Frame Assembly 130
2	AFB-00054	Bolt, 1/2" NC x 3-1/2" w/ 7500 nut
3	AHF-00028	Greasefitting 90° 1/8 NPT
4	A10152A	Pin, Frame attachment, 2" OD x 8-1/16" Long
5	AFB-00081	Bolt, 7/8" NF X 5" NF
6	7597	Nut, 7/8" NF
7	8125	Lockwasher, 7/8"
8	A14002	Cast socket half, rear
9	A14003	Cast socket half, front w/ zerk hole
10	A2206	Grease zerk, long shank"
11	A14039	Bushing, 2.375 OD x 2.00 ID x 2" Long, grease Passage
12	OPT-00001	Hitch jack
13	A030672-33	Dog Bone
14	A125006	Safety Snap Pin

ASHLAND SCRAPERS

Apron Assembly (130-1020)

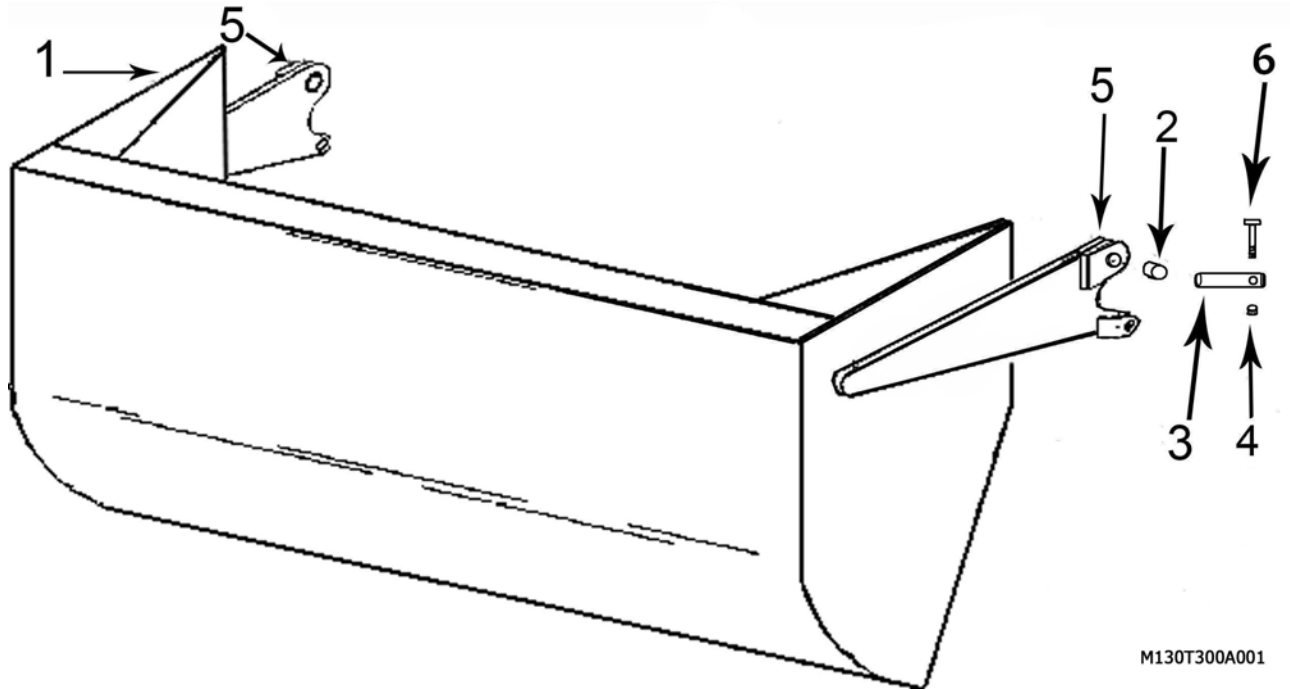

M130T300A001

KEY	PART	DESCRIPTION
1	A123341	Apron
2	A123343	Bushing: 2" OD X 1-1/2" ID x 1-3/4" L
3	A123337	Pin: 1 1/2" X 5 3/8"L
4	7450	Nut: 3/8 NC
5	14505	Grease fitting
6	AFB-00049	Bolt: 3/8 NC X 3"

Bowl & Frame Assembly (110-130-860-1020)

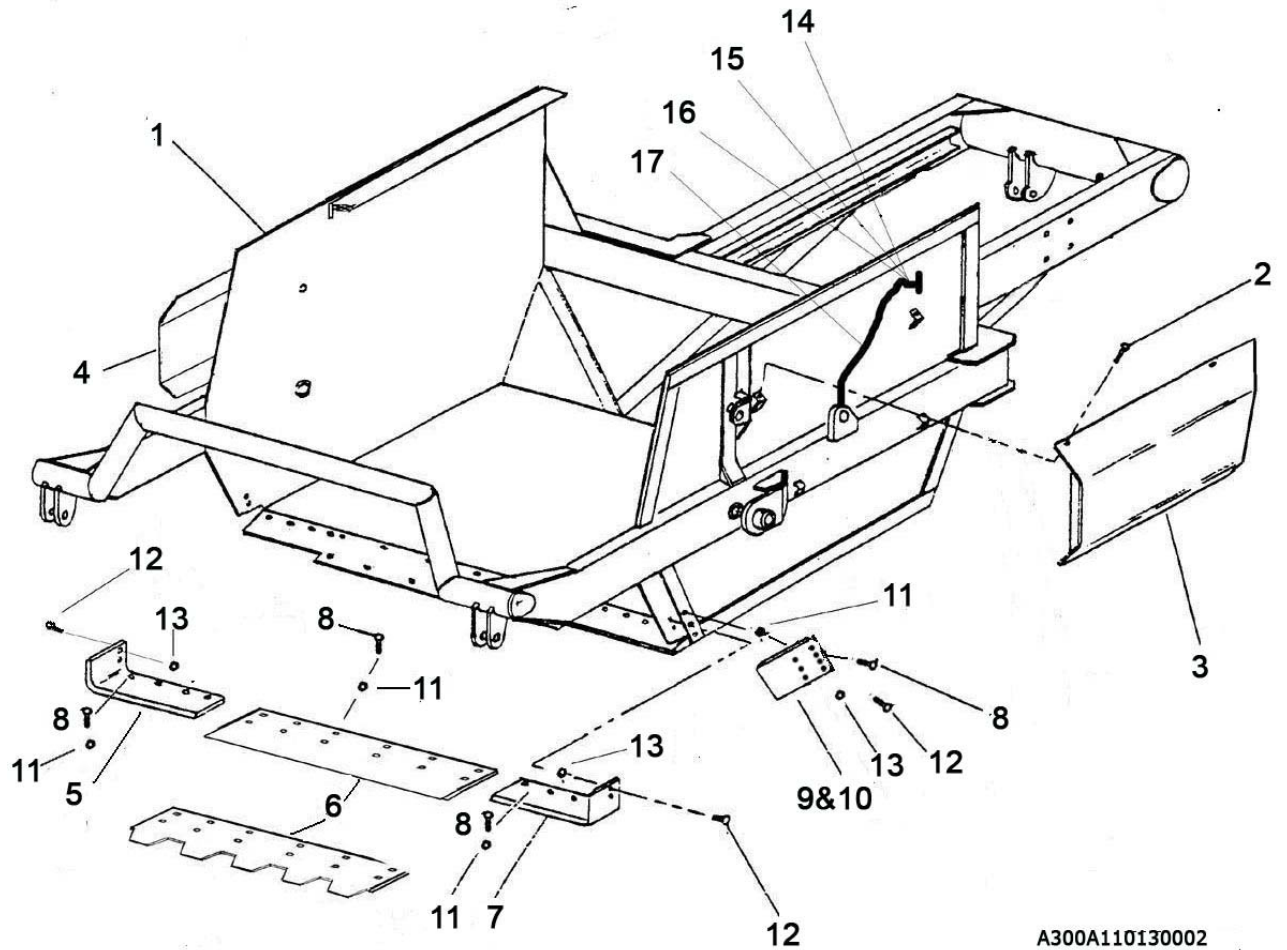

Blade Bolts Required:	Bolts	Nuts	Qty
A123331 (& Ser)	PB9P-NC-088-0275	AFN-00019	12
A123332L & R	PB9P-NC-088-0275	AFN-00019	4
	PB9P-NC-088-0225	AFN-00019	2
A123338L & R	PB9P-NC-088-0275	AFN-00019	4
	PB9P-NC-088-0225	AFN-00019	3

KEY	PART	DESCRIPTION	SN 130XL2
1	A123164	Bowl and Frame I-130XL2	
2	AFB-00094	Flanged Bolt: 3/8 NC X 1"	
3	501896	Apron Cylinder Guard - Left Side (Yellow or Gray?)	
4	501897	Apron Cylinder Guard - Right Side (Yellow or Gray?)	
5	A123332R	Right Cutting Edge-8" X 22 1/2" X 7/8" Hardened	20413-XXXXX
6	A123331	Center Cutting Edge, 13" x 54" Hardened	20413-XXXXX
	A123331-SER	Center Cutting Edge, (Optional) Serrated 1-1/8" x 12" x 63"	20413-XXXXX
7	A123332L	Left Cutting Edge-8" X22 1/2" X 7/8" Hardened	20413-XXXXX

ASHLAND SCRAPERS
Bowl & Frame Assembly (110-130-860-1020)

KEY	PART	DESCRIPTION	SN 130XL2
8	PB9P-NC-088-0275	"Plow bolt, 7/8" NC x 2-3/4"	20413-XXXXX
9	A123338L	(Optional) Left Bank Shaver Side Blade	20413-XXXXX
10	A123338R	(Optional) Right Bank Shaver Side Blade	20413-XXXXX
11	AFN-00019	Nut: 7/8" NC	20413-XXXXX
12	PB9P-NC-088-0225	"Plow bolt, 7/8" NC x 2-1/4"	20413-XXXXX
13	AFN-00026	Nut: 7/8" NC Jam	20413-XXXXX
14	A125019	Grease fitting 1/4-28 x .54" long	
15	A125026	Bulkhead nut 1/8 n.p.s.m.	
16	A123309-89	Single Hole Tab	
17	A125022	18" Grease Line	

Assembly - Push Off (110-130)

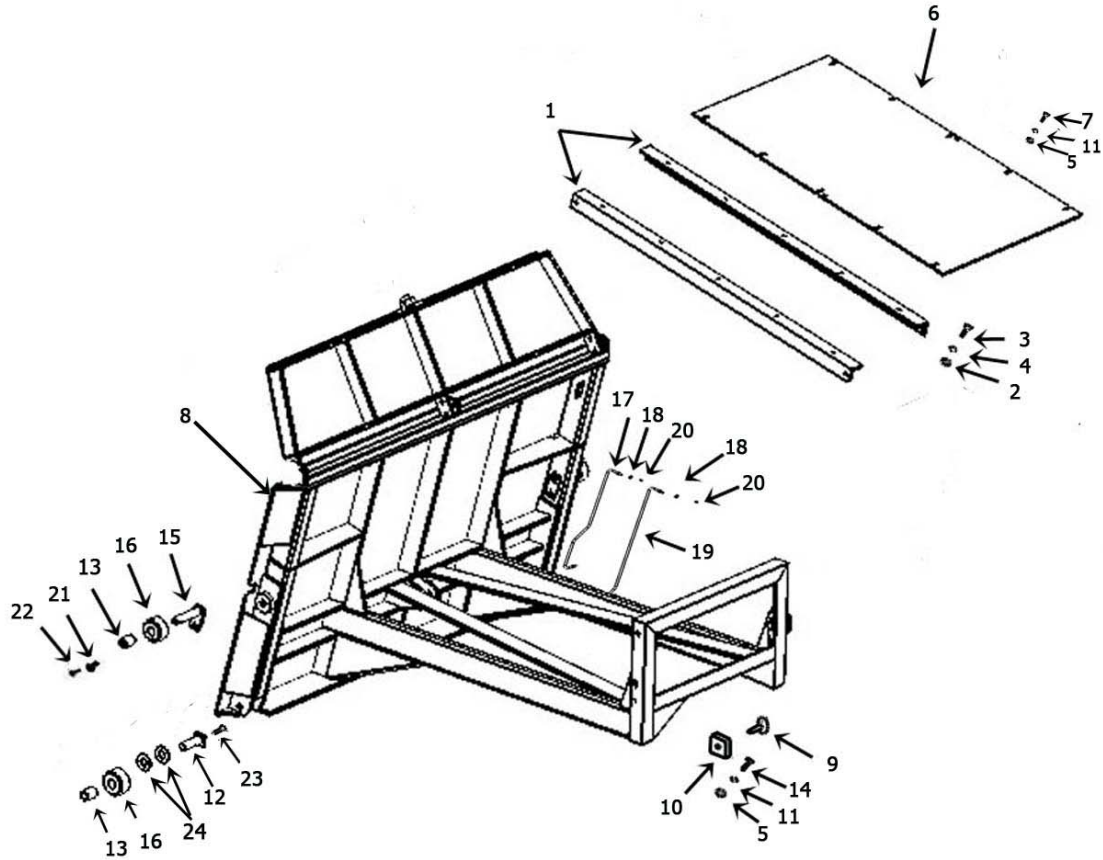

A300A110130006

KEY	PART	DESCRIPTION	SN 130XL2
1	A10159	Brace (L.H. & R.H. same)	
2	AFN-00006	Nut: 3/4" NC	
3	AFB-00037	Bolt: 3/4" NC x 2" Lg.	
4	AFW-00002	Lockwasher: 3/4"	
5	7500	Nut: 1/2" NC	
6	A10171	Dirt Shield	
7	AFB-00019	Bolt: 1/2" x 1-1/2" NC bolt	
8	A16024	Pushoff Gate: Model 130	22081-XXXXX(except 22083 old)
9	A123305A	Pin: 1-1/4" x 2-3/4"	
10	A123353	Wear Pad	
11	8100	Lockwasher: 1/2"	
12	A123323-21	Pin: Pin: Lower Roller 1 1/4" X 5 1/4"	
13	A10163	Bushing: 1-3/4" OD x 1-1/4" ID	
14	AFB-00033	Bolt: 1/2 NC X 2 1/2" Gr. 8	
15	500465	Pin: 1/4 X 7"	

ASHLAND SCRAPERS**Assembly - Push Off (110-130)**

KEY	PART	DESCRIPTION	SN 130XL2
16	A10164	Roller:4-1/4" OD x 1-3/4" ID	
17	A125020	32" grease line	
18	A125026	Bulkhead Nut	
19	A125021	54" greaseline	
20	A125019	Greasefitting 1/4-28 .54" long	
21	A123358	Pin Keeper Bushing	
22	AFB-00079	Bolt: 5/8" X 1 1/2" Gr. 8	
23	AFP-00001	Cotter Pin: 1/4 X 3 1/2"	
24	AFW-00015	Washer: 1 1/4" Flat	

ASHLAND SCRAPERS

Pole & Axle Assembly (130)

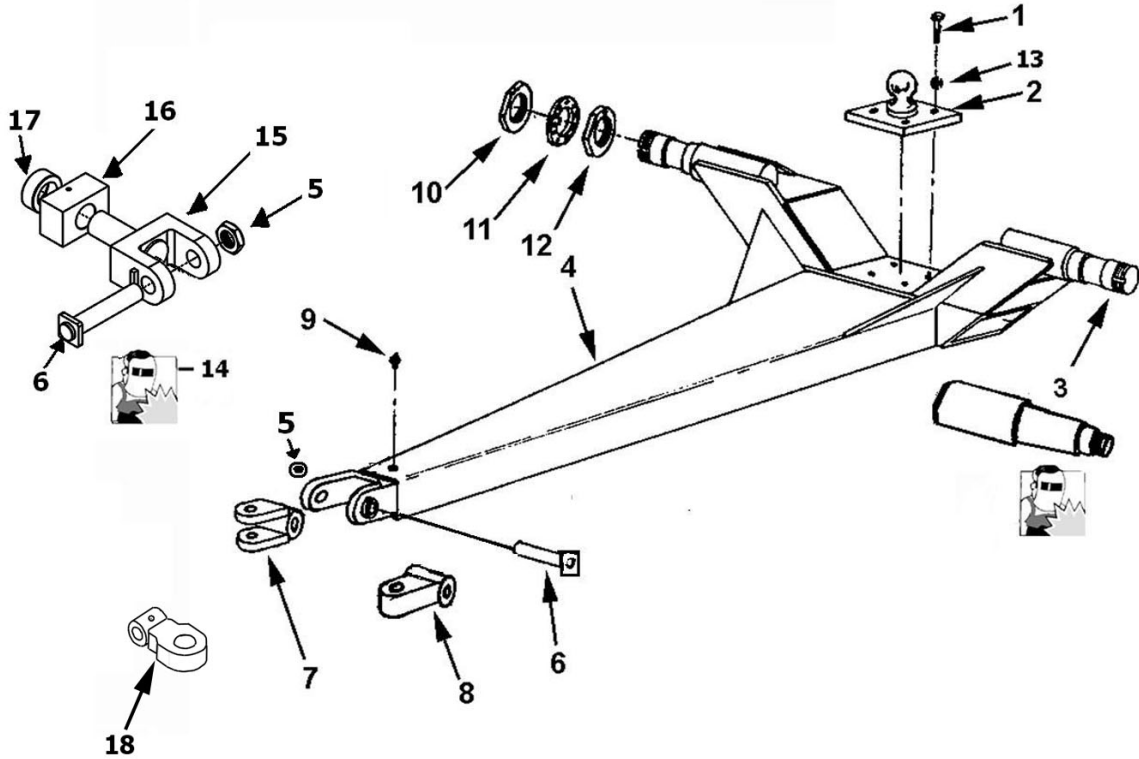

M130X300A005.1

KEY	PART	DESCRIPTION	SN 130XL2
1	AFB-00018	Bolt, 1" NC X 3" lg.	
2	A14017	Ball Swivel	
3	500581	Flat Sided spindle (weld on)	XXXXX-23339
3	A14021	Spindle (weld on)	23340-XXXXX
4	A13006	Pole	
5	500462	Nut, Swivel Pin	
6	600055	Pin, Swivel Hitch	
7	A17511	Swivel hitch, double lip (optional)	
8	A17510	Swivel hitch, single lip	
9	14505	Grease fitting	
10	A10048	Spindle Nut	
11	A10049A	Lock collar	
12	A10172	Nut w/lock pin	
13	AFW-00006	Lockwasher, 1"	
14	A123232A	Yoke hitch rebuild kit: (includes block, collar, yoke, pin, nut (5,6,15,16,17))	
15	A123232-3	Swivel Yoke Assembly	
16	A123232-2	Swivel Block	
17	A123232-1A	Retaining Collar	
18	A17512	Hitch: Single Lip Swivel - Cat 5 - (Optional) (2 3/4") pin	

ASHLAND SCRAPERS

Assembly - Wheel Front (130)

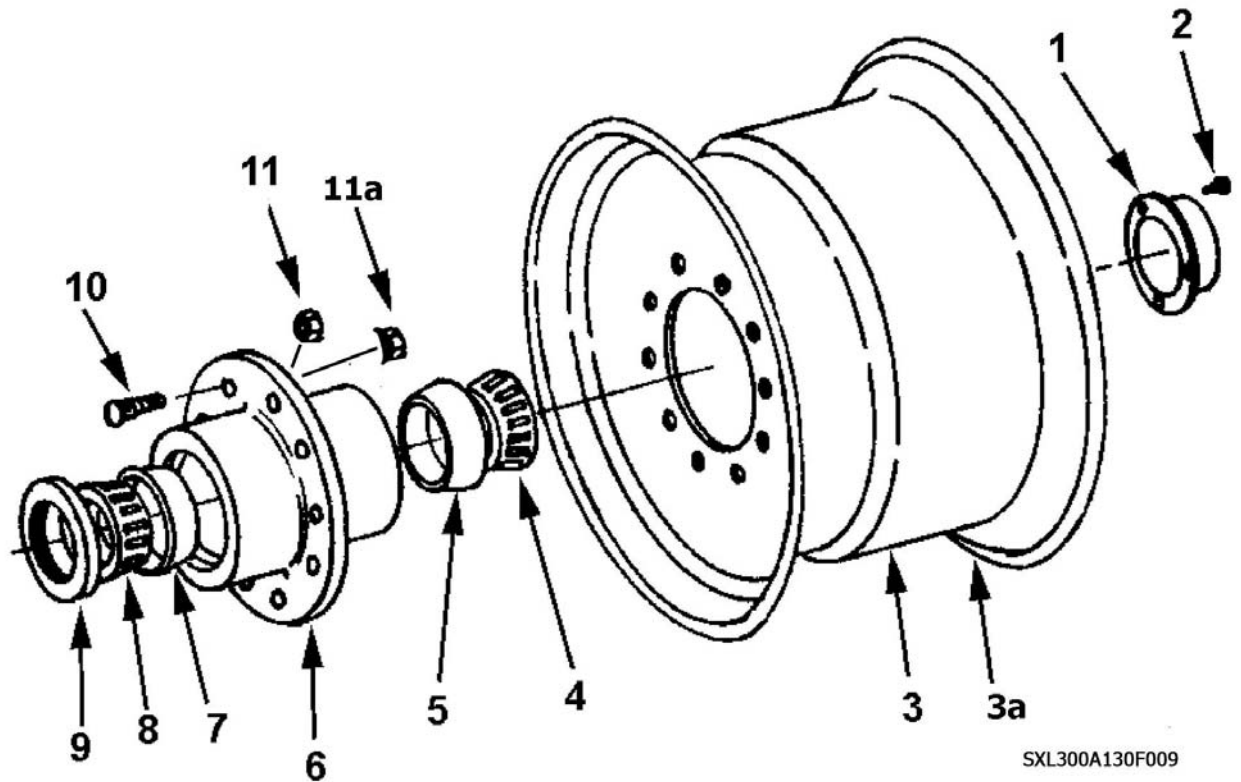

KEY	PART	DESCRIPTION
1	A14004	Hub Cap
2	AFB-00080	Bolt, 5/16 NC X 1/2 L.
3	A13007	18 X 16.1 Wheel, Old Style Rim (has gussets/chamfer holes
3a	A13007A	18 X 16.1 Wheel, New Style Rim (uses flanged wheel nut)
4	A14015	Bearing Cone
5	A14014	Bearing Cup
6	A14010A	Hub
7	A14013	Bearing Cup
8	A14012	Bearing Cone
9	A14011	Grease Sear
10	A10176	Stud
11	A10046	Lug Nut
11a	A125346	Flanged Nut

ASHLAND SCRAPERS

Rear Wheel Assembly (110X-130X)

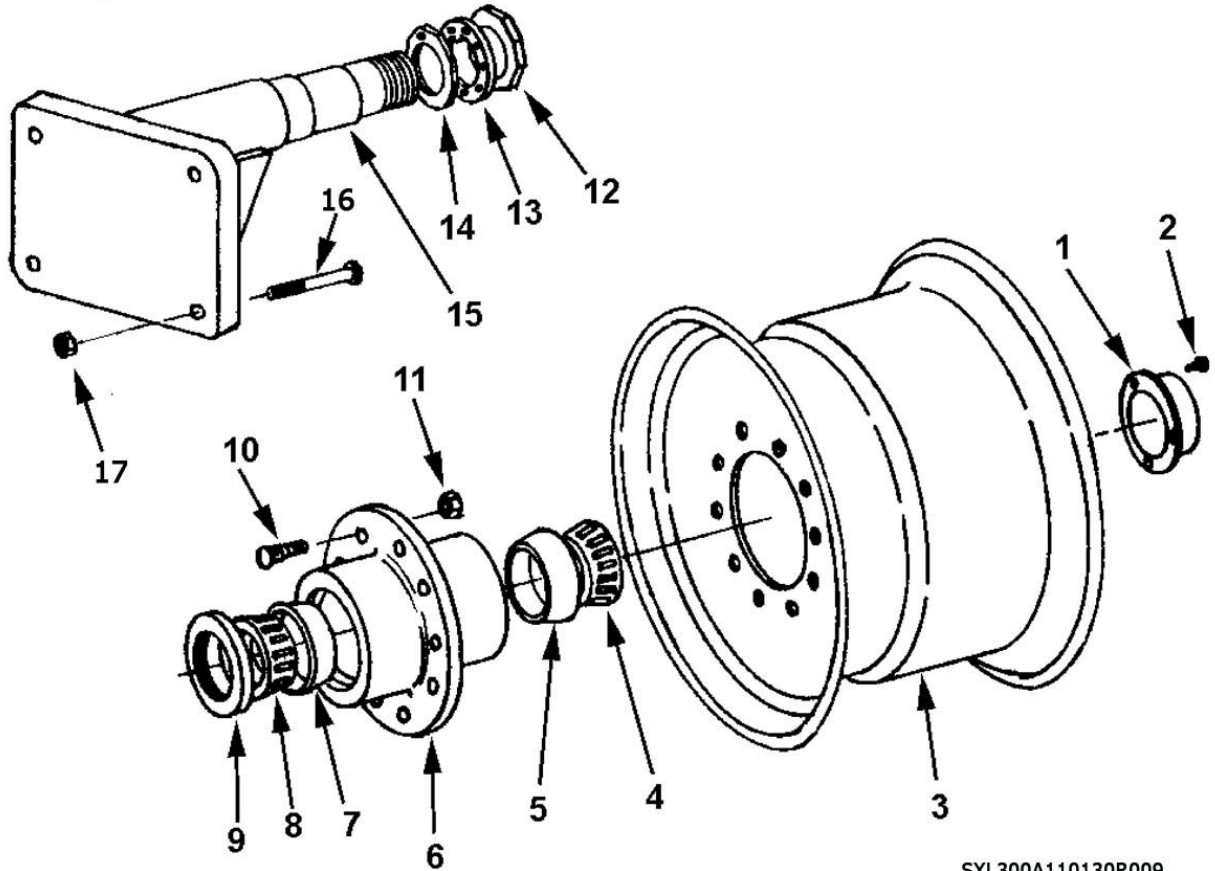

SXL300A110130R009

KEY	PART	DESCRIPTION
1	A14004	Hub cap
2	AFB-00080	Bolt, 5/16 NC x 1/2 lg.
3	A10039	Wheel, 16 x 26 Drop Center
4	A14015	Bearing cone (Timken 644)
5	A14014	Bearing cup (Timken 632)
6	A14010A	Hub, Blank, less cups + studs
7	A14013	Bearing cup (Timken 742)
8	A14012	Bearing cone (Timken 749)
9	A14011	Grease seal (CR 42624)
10	A10176	Stud
11	A10046	Lug nut
12	A10048	Spindle nut
13	A10049A	Lock collar
14	A10172	Nut w/ lock pin
15	A14037	Spindle
16	AFB-00017	Bolt: 1" NF X 6 1/2 L.
17	AFN-00001	Nut, 1" NF Toplock

ASHLAND SCRAPERS

Assembly - Wheel Rear (130X) Optional

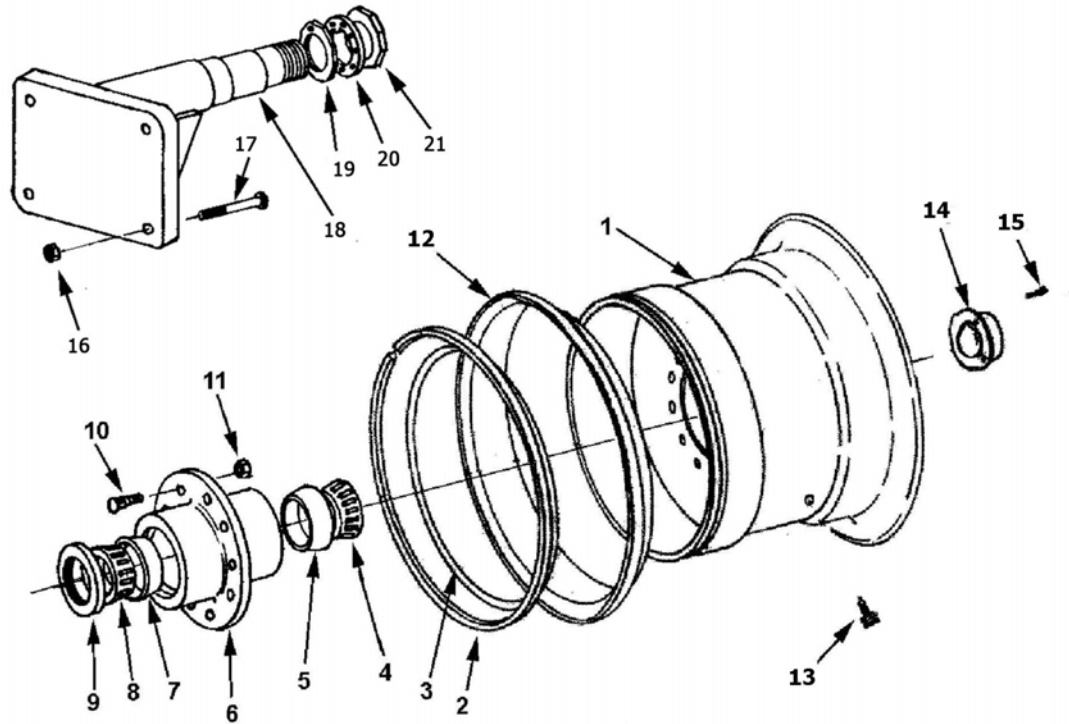

SXL300A130R009-0

KEY	PART	DESCRIPTION
1	A14035	Wheel - 17" x 25"
2	A14038	Lock Ring
3	A14008	O-Ring
4	A14015	Bearing cone
5	A14014	Bearing Cup
6	A14010	Hub
7	A14013	Bearing Cup
8	A14012	Bearing Cone
9	A14011	Grease Seal
10	A10176	Stud
11	A10046	Lug Nut
12	A14036	Slide Ring
13	A14016	Valve Stem
14	A14004	Hub Cap
15	AFB-00080	Bolt, 5/16" NC X 1/2 L.
16	AFN-00001	"Nut, 1" NF Toplock"
17	AFB-00017	Bolt, 1" NF x 6-1/2" lg.
18	A14037	Spindle
19	A10172	Nut with lock pin
20	A10049A	Lock Collar
21	A10048	Spindle Nut

ASHLAND SCRAPERS

Apron Cylinder (#A125050) 4" X 13"

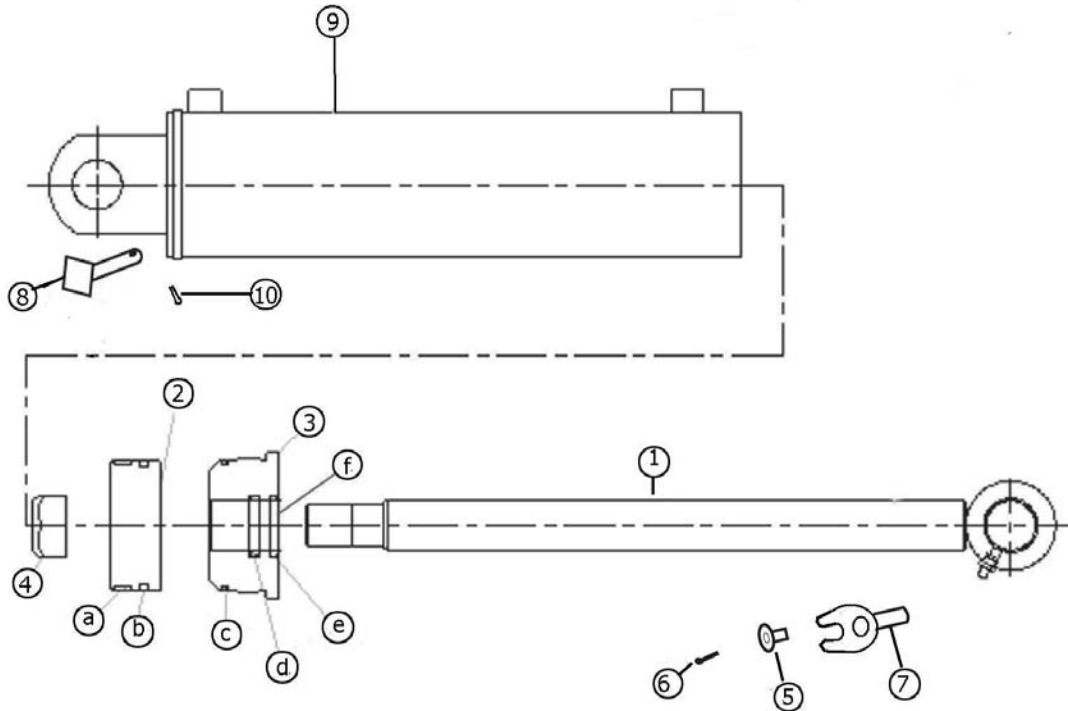

A350P004

KEY	PART	DESCRIPTION
	A125050	APRON CYLINDER 4" X 13"
1	A125050-01	Rod 1-3/4" with welded eye
2	A125050-02	Piston
3	A125050-03	Gland, Threaded
4	A125050-04	Lock Nut, 1-1/8" NF
5	A123351	Pin Keeper Bushing
6	AFB-00019	1/2" x 1 1/2" Gr 8 Bolt
7	A123362	Pin: Cyl. Rod End 1 1/2 X 4 1/2 w/ Tab
8	A123363	Pin: Cyl. Base End 1 1/2 X 4 1/8"
9	A125050-06	Cylinder Barrel
10	8602	Cotter Pin: 1/4 X 2
	A125050-05	Seal Kit Containing (a-f)
a		Nylon Wear Ring
b		FSP Seal
c		O-Ring
d		Backup Washer
e		Hallite Rod Seal
f		Snap in Rod Wiper

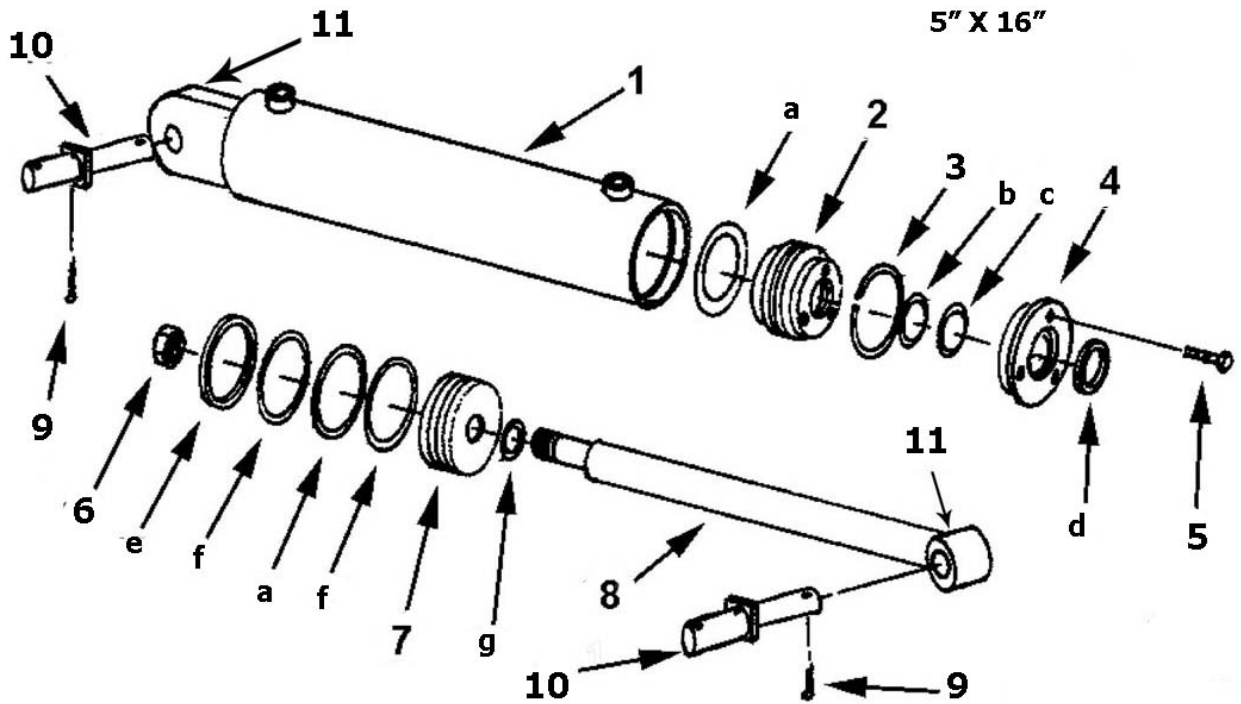
ASHLAND SCRAPERS
Lift Cylinder (#A516H114) 5" X 16"

A350P017

KEY	PART	DESCRIPTION
	A516H114	LIFT CYLINDER 5" X 16"
1	A130H27	"Barrel Assembly, 5" ID"
2	A400H10	"Head gland, 5" OD"
3	A400H11	Retainer ring
4	A400H13	Head cap
5	22H18A	"Capscrew, 5/16" NC x 1"
6	A400H17	"Lock nut, 1-1/4" NF"
7	A400H07	"Piston, 5" OD"
8	A130H28	"Shaft, 2" dia."
9	8602	"Cotter pin, 1/4" x 2"
10	A123383	"Pin, 1-1/4" x 7"
11	14505	Grease Fitting
	A400H15C	Seal Kit containing:
a	A400H06	"O-ring, 5" OD x 1/4"
b	A400H12A	"Backup washer, 2" ID"
c	A400H12	"O-ring, 2" ID"
d	A400H14	Wiper seal
e	A400H04	"Cast iron ring, 5" OD"
f	A400H05	"Backup washer, 5" OD"
g	A60H52	"O-ring, 1-1/4" ID x 1/8"

ASHLAND SCRAPERS

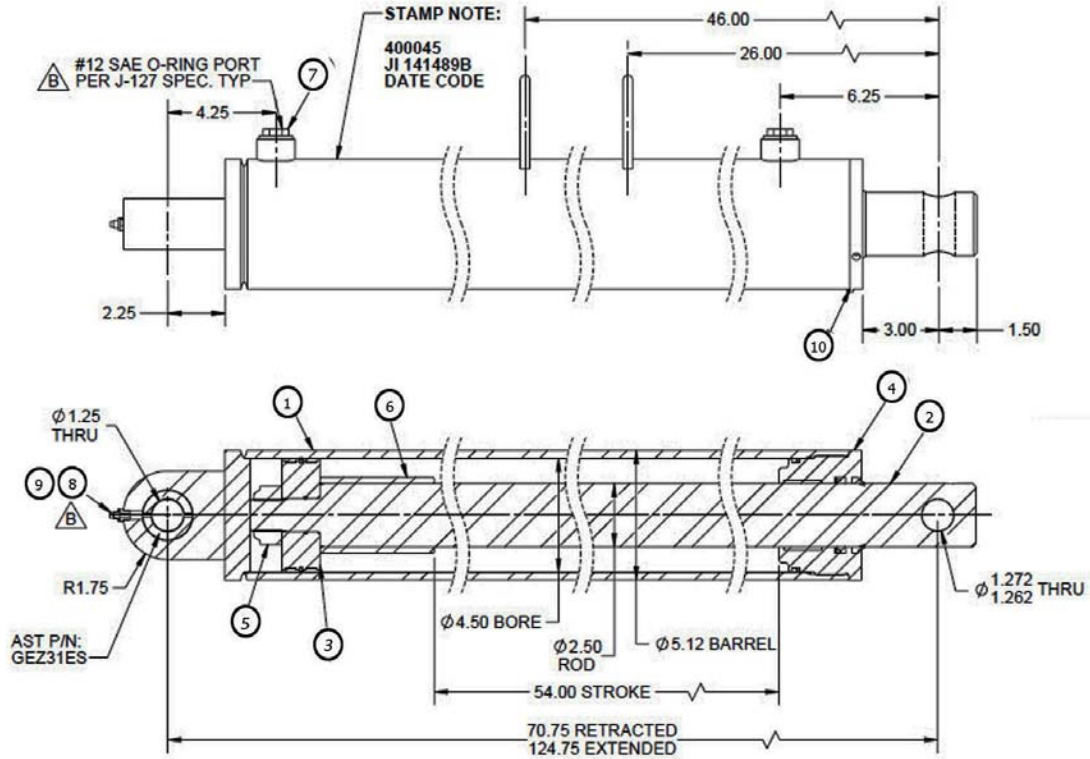
Push Off Cylinder (400045) 4 1/2 X 54"



KEY	PART	DESCRIPTION	SN 130XL2
	400045	PUSH-OFF CYLINDER	23814-XXXXX
1	204145B	Barrel	
2	316480B	Rod	
3	401405A	Unitized Piston 4.50	
4	500422B	Rod Bearing Assembly	
5	712025A	Nut-Self Locking	
6	320750B	Stroke Limiter	
7	714048A	Plastic Plug O-ring	
8	714165A	Shipping Cap	
9	717000A	Grease Fitting	
10	711127A	Screw: Locking	

ASHLAND SCRAPERS

Hydraulic Manifold (#A125174)

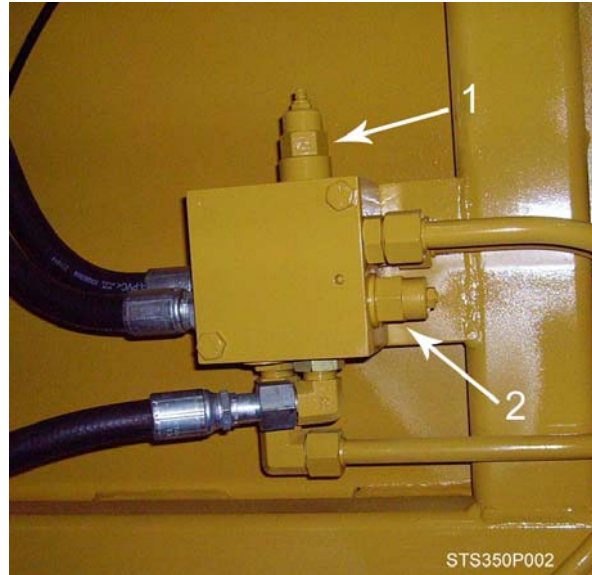

KEY	PART	DESCRIPTION
1	A125162-02	PUSHOFF SEQUENCE CARTRIDGE
2	A125162-01	COUNTER BALANCE CARTRIDGE

SETTING THE APRON AND PUSHOFF VALVE

The manifold block containing the pushoff sequence valve cartridge and apron sequence valve cartridge is used to control two hydraulic circuits with one hydraulic remote. When the tractor hydraulic remote is activated, oil flows first to the apron cylinders until they are fully extended. Once the cylinders are fully extended, the apron circuits' hydraulic pressure begins to increase. Once the pressure threshold is surpassed (which is adjustable. See adjustment section), the sequence valve diverts the oil flow to the pushoff's hydraulic circuit. Once the push off is completely extended the operator then reverses the tractors hydraulic remote. The counterbalance valve will hold the apron open until the push off is fully retracted. The Apron sequence valve then opens and allows the apron to close.

Setting the valves:

STEP 1 PUSHOFF SEQUENCE VALVE

Loosen the lock nut (9/16") on the sequence valve cartridge. Turn the setscrew (4mm) clockwise until the front apron rises before the push-off begins to advance. (Earthmover should be empty) Turn the adjustment screw an additional 1/4 turn clockwise and tighten jam nut.

STEP 2 COUNTER BALANCE VALVE

Loosen the lock nut (9/16") on the counterbalance valve cartridge. Turn the setscrew (4mm) counter-clockwise until the apron holds in a raised position while rear gate is being retracted. Turn adjustment screw an additional 1/4 turn, tighten jam nut. DO NOT tighten adjusting screw more than necessary.

ASHLAND SCRAPERS

Hydraulic Valve Ports Assembly

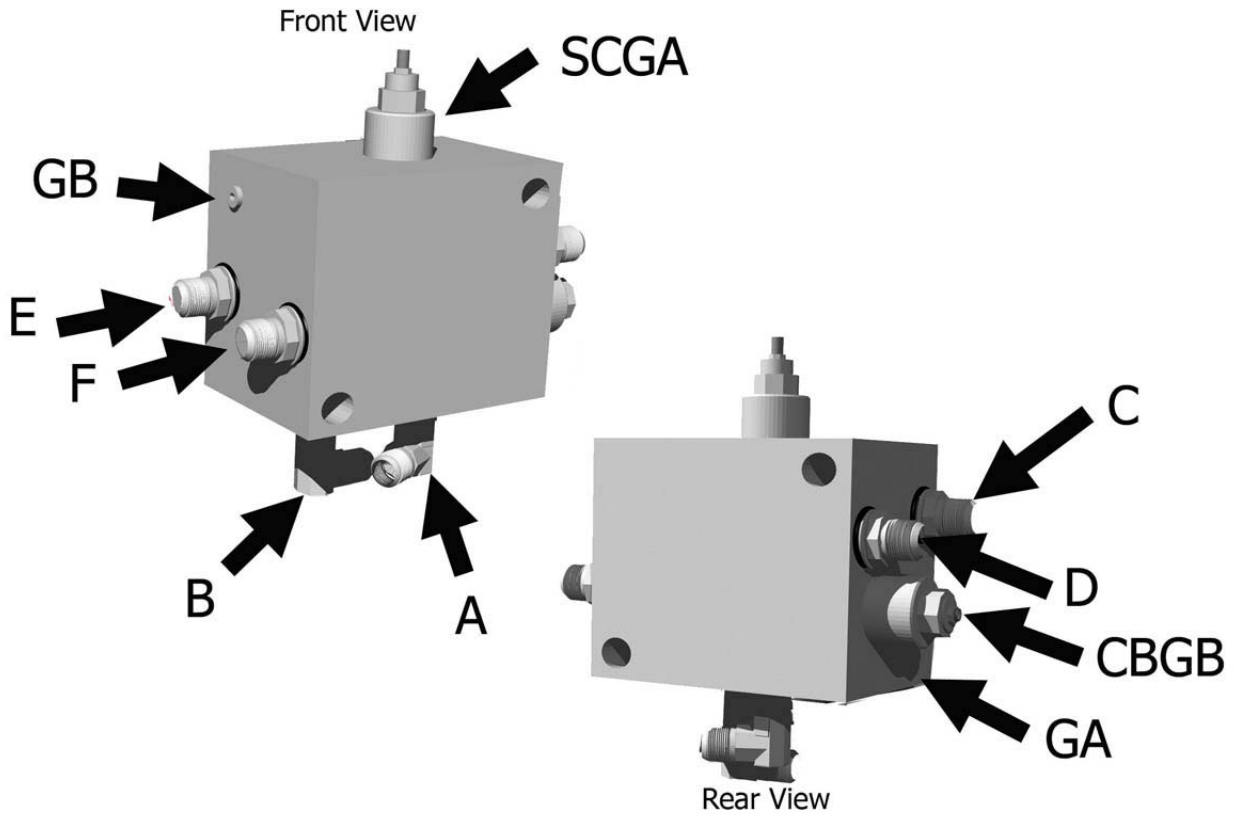

The lettering for the port locations are stamped on the block

A350P010

KEY	PART	DESCRIPTION
A		Supply Line
B		Pushoff Cyl. (Rod End)-Apron Cyl., Right side (Rod end)-Supply Line
C		Pushoff Cylinder, (Base End)
D		Apron Cylinder, Right side, (Base End)
E		Apron Cylinder, Left side, (Rod End)
F		Apron Cylinder, Left side, (Base End)
CBGB		Counterbalance Valve, adjustable
SCGA		Sequence Valve, adjustable
GA		Pressure test port
GB		Pressure test port

ASHLAND SCRAPERS
Hydraulic Valve Seals

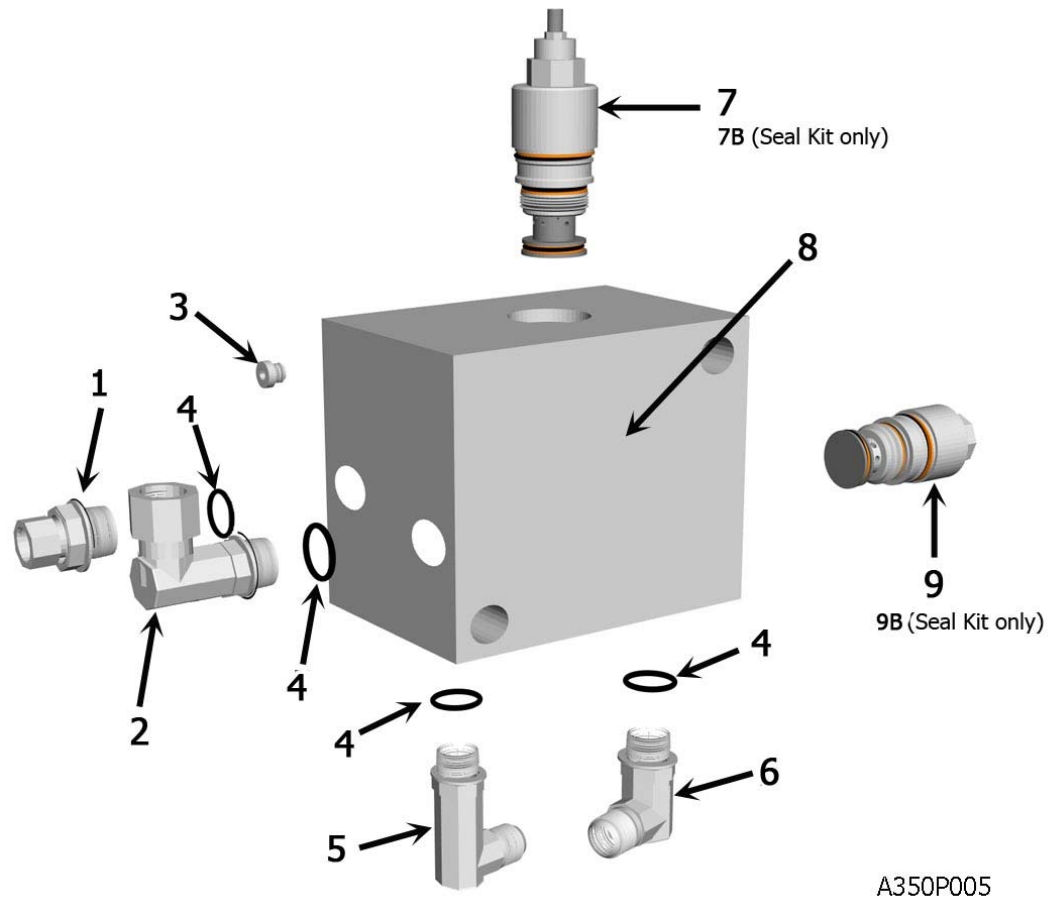

KEY	PART	DESCRIPTION
1	AHA-00043	Adapter: Str. Sw. 1 1/16 M ORB X 1/2 FP
2	AHA-00048	Adapter: 90 Deg. Swiv. 1 1/6 M ORB X 1/2 FP
3	AHA-00046	6 ORB Plug
4	AHS-00153	O-Ring for 12 M ORB Fitting
5	AHA-00047	Adapter: 90 Deg. XL 3/4 MJX 1 1/6 M ORB
6	AHA-00044	Adapter: 90 Deg. 3/4 MJ X 1 1/6 M ORB
7	A125162-02	Valve: Sequence Cartridge for Ver. III & IV
8	A125174	Valve: Manifold Block IV Body
9	A125162-01	Valve: Counterbalance Cartridge for Ver. III & IV
9B	A125162-01 KIT	Seal Kit for A125162-01 Valve Cartridge
7B	A125162-02 KIT	Seal Kit for A125162-02 Valve Cartridge

ASHLAND SCRAPERS

Hydraulic Plumbing Front (I-110-130)

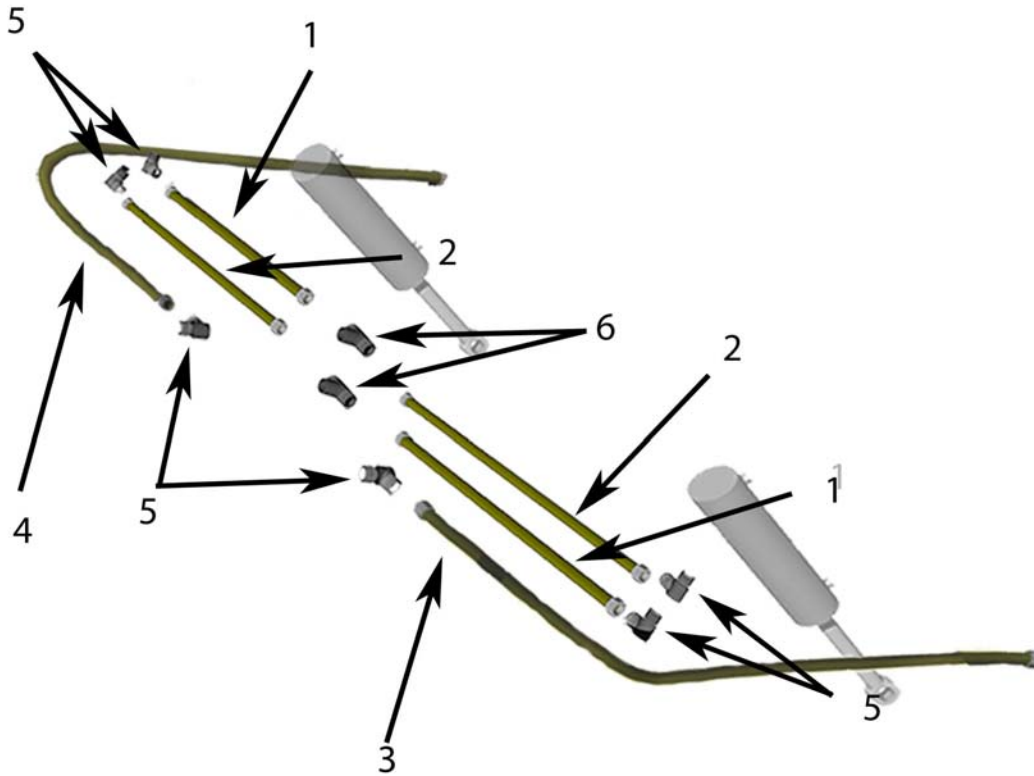

A400H110130XF

KEY	PART	DESCRIPTION
1	A123398	Tubing, Arm, Left Side
2	A123397	Tubing, Arm, Right Side
3	A123399	Tubing, Front Section Straight
4	A123400	Tubing, Front Section, Straight
5	A123400	Tubing, Front Section, Straight
6	A123399	Tubing, Front Section, Straight
7	AHA-00022	Adapter
8	AHA-00019	Adapter: 90 Deg.

ASHLAND SCRAPERS

Hydraulic Plumbing Rear (I-110-130)

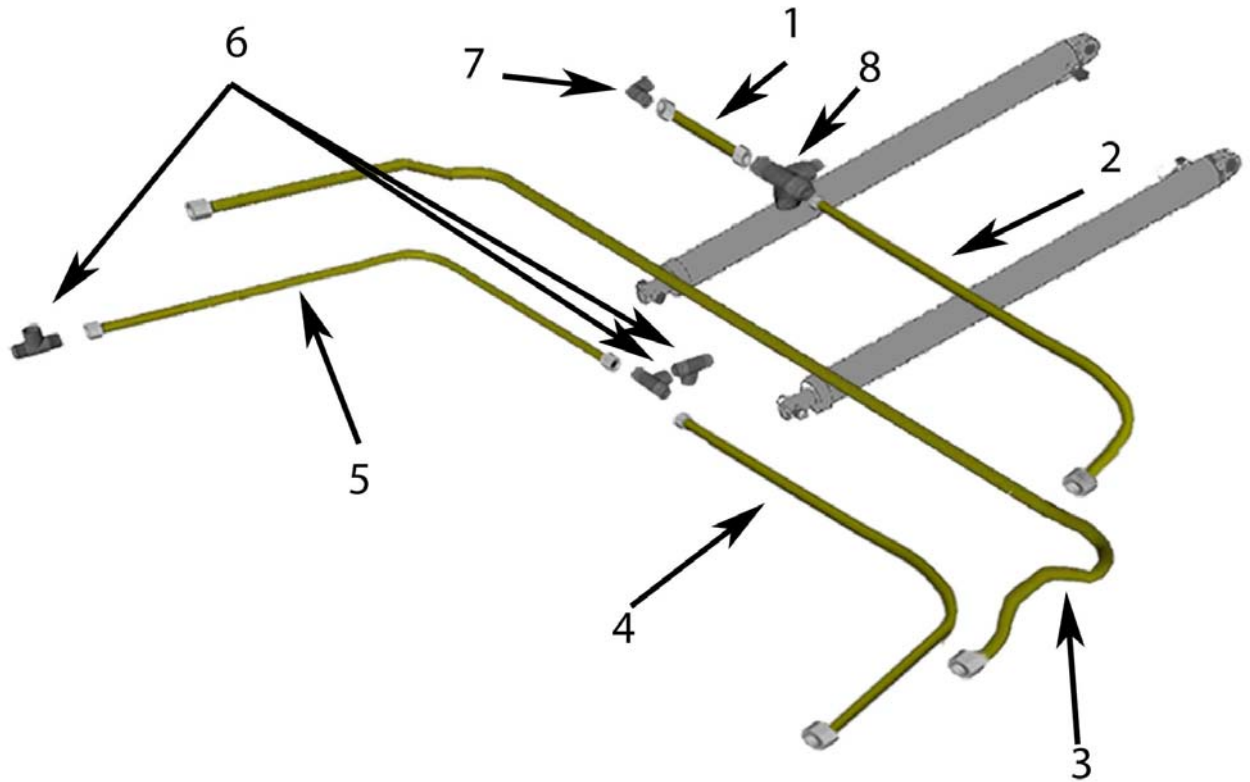

A400H110130XR

KEY	PART	DESCRIPTION
1	A123394	Tubing, Behind Bowl, Lower Left Side
2	A123392	Tubing, Behind Bowl, Right Side
3	A123393	Tubing, Upper Left Side, Around Bowl
4	A123405	Tubing, Bowl, Rear Center
5	A123391	Tubing, Behind Bowl, Wrap Around Right & Left Sides
6	AHV-00001	Valve: Pressure Relief

ASHLAND SCRAPERS
Hydraulic Hoses (I-130XL2)

KEY	PART	DESCRIPTION
1	A125274	Hose-R. Side Feed Line from "T" to Front Sect. - 65"
2	A125275	Hose-R. Side Apron Rod End to "T" - 50"
3	A125276	Hose-R. Side Apron Cyl. Barrel End to Inner Back Tube-25"
4	A125277	Hose-L. Side Feed Line "A" on valve to Front Sect. - 66"
5	A125278	Hose-L. Side Apron Cyl. Barrel End to "F" on Valve - 21"
6	A125279	Hose-L. Side Apron Rod End to "E" on Valve - 30"
7	A125280	Hose-L. Side From "C" on Valve to Top Outer Tubing - 17.5"
8	A125281	Hose-Rear Top Outer Line to Barrel End Pushoff - 71"
9	A125282	Hose-Rear "T" to Pressure Relief Valve
10	A125283	Hose-Rear from Rod End of PUSHoff to "T" Fitting - 16"
11	A125284	Hose-Front Bottom Inside Tube to Bottom L & R Bulkhead - 21"
12	A125285	Hose-Front Top Outer Tube to Center Left Bulkhead - 19"
13	A125286	Hose-Front top Inside Tube to Center Right Bulkhead - 22"
14	A125287	Hose-Front Top R & L Tube to Barrel End Lift Cyl. -24"
15	A125288	Hose-Front Inside Top R & L Tube to Rod End Lift Cyl. -50"
16	A125289	Hose-Front Connecting Hook-up Hoses to Bulkhead - 138"

ASHLAND SCRAPERS

Hydraulic Hoses (I-130XL2) Illustration

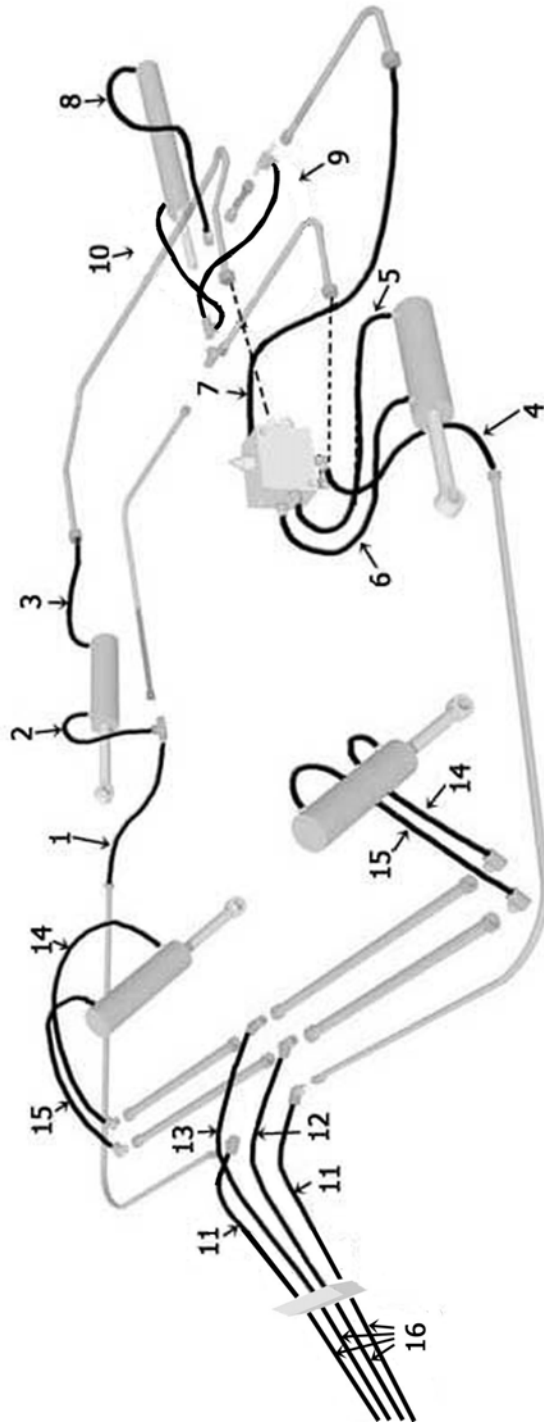

M130X400H005

ASHLAND SCRAPERS

Hydraulic Schematic: I-130XL2

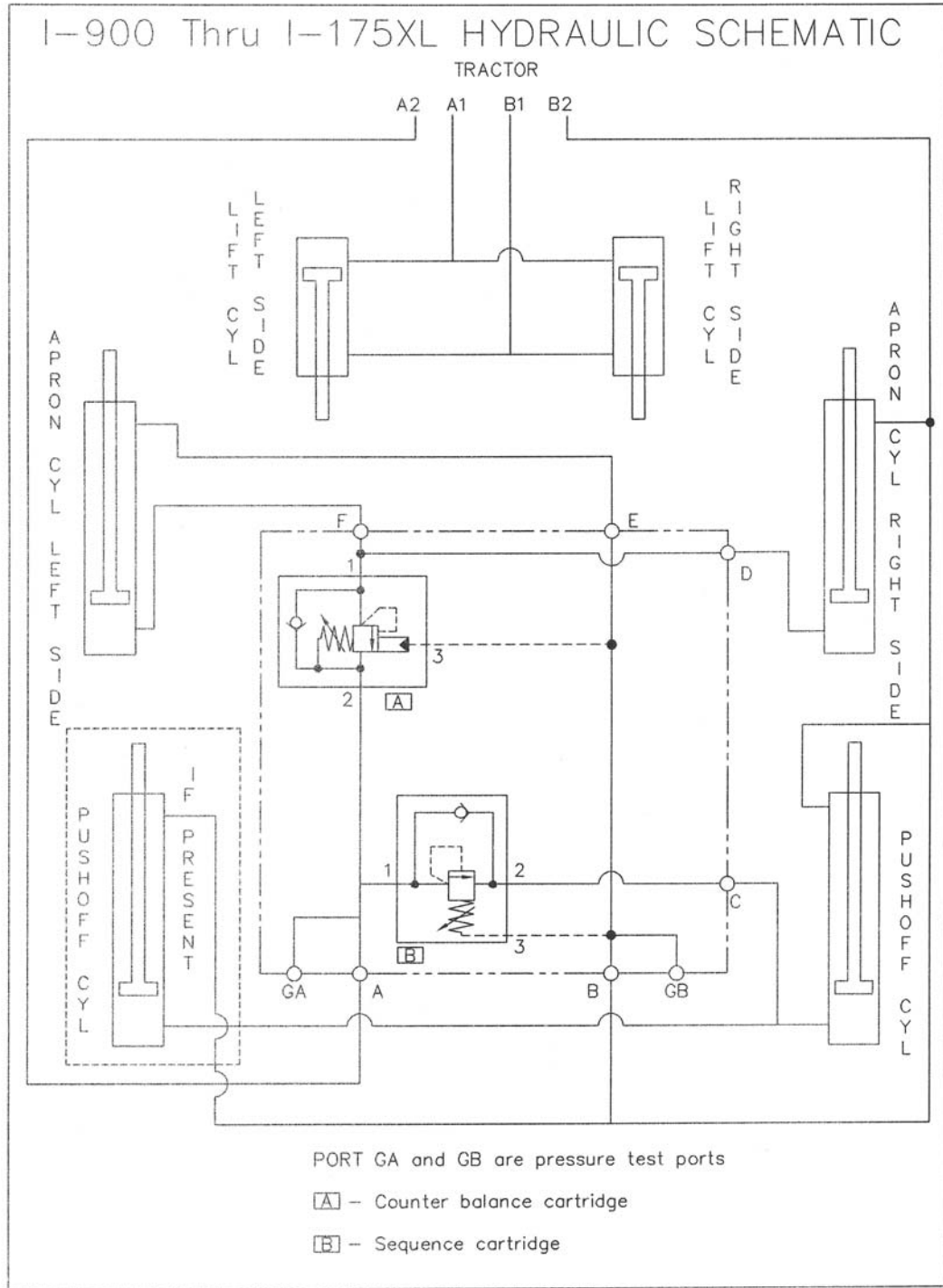

A400H003

ASHLAND SCRAPERS

Tire Inflation & Torque Charts

TIRE INFLATION (PSI)				
Scraper Model	Front Tire Size (XL)	Max PSI	Rear Tire Size	Max PSI
950	16.5-16.1 ANS 10 Ply	36	16.9-24 ANS 8 Ply	24
110	16.5L-16.1 ANS 10 ply	36	18.4-26 ANS 10 Ply	26
130	21.5-15.1 10 Ply	28	18.4-26 ANS 12 Ply	32
155	20.5-25 12 Ply	51	29.5 X 25 28 Ply	62
175	20.5-25 12 Ply	51	29.5 X 25 28 Ply	62
180TS			29.5 X 25 28 Ply	62
180CS			23.5 X 25 12 Ply	54
200			20.5-25 12 Ply	65

On new machines, the wheels should be retorqued after the first two hours of use. Then check tires daily to ensure correct inflation levels. Check tire pressure with an accurate gauge having 6.9 kPa (0.07 bar) 1 psi) gradations.

Check tires daily to ensure correct inflation levels. Also check for:

- Tire Damage
- Loose or missing wheel lugs, nuts or caps
- Uneven wear
- Damaged Rims

Torque Ft-lbs	Lug nuts (by model)
85-100	900-950
450	110-130
450	155-175 front
750	155-175 rear
450-500	180TS-180CS
750	200
Torque Ft-lbs	Bolt Diameter
12	¼"
25	5/16"
45	3/8"
70	7/16"
110	½"
150	9/16"
220	5/8"
380	¾"
600	7/8"

ASHLAND SCRAPERS

Tire Warning



The task of servicing tires and wheels can be extremely dangerous and should be performed by trained personnel only, using the correct tools and following specific procedures. Do not attempt to mount, demount or inflate a tire if you do not have the proper equipment and experience to perform the job. Call a qualified repair service to inspect the assembly and make necessary repairs. Failure to heed warnings could lead to serious injury or death.

Visually inspect tires and wheels daily. Carefully inspect any rim and tire assembly that has been run underinflated or flat before reinflating the tire to make sure there is no damage to either the rim or tire.

- ALWAYS wear personal protection equipment such as gloves, footwear, eye protection, hearing protection and head gear when servicing tire and wheel components.
- DO NOT operate with damaged rims, tire cuts or bubbles, missing lug bolts or nuts or damaged rims.
- ALWAYS maintain the correct tire pressure. NEVER exceed recommended tire inflation pressure.
- INSPECT any rim and tire assembly that has been run flat or severely underinflated before reinflating the tire. Damage to the rim and tire may have developed.
- NEVER inflate a tire that has lost air pressure or has been run flat without determining and correcting the problem.
- NEVER try to repair wheel, rim, or tire components parts. Parts that are cracked, worn, pitted with corrosion, or damaged must be discarded, and replaced with good parts.
- ALWAYS use approved tire and rim combinations for the model scraper that you have and verify that part numbers of components are correctly matched for the assembly.
- ALWAYS exhaust all air from the tire prior to demounting.
- ALWAYS place wheel and tire assemblies in restraining devices (safety cage) when inflating tires. Use a clip-on chuck and long extension hose to allow you to stand to the side of the tire and not in front of it.
- NEVER weld or cut on an inflated tire assembly. Welding heat can cause increased pressure which could result in tire explosion.
- ALWAYS use proper lifting techniques, and mechanized lifting aids to move heavy components and assemblies.
- NEVER leave a tire, wheel, or assembly unsecured in a vertical position.
- ALWAYS take care when moving tires and wheels that other people in the area are not endangered.

ASHLAND SCRAPERS
Scraper Specifications I-130XL

I-130XL2 SPECIFICATIONS

CAPACITY, STRUCK	10.2 cu yd	7.8 cu m
CAPACITY, HEAPED	13.3 cu yd	10.2 cu m
OVERALL DIMENSIONS: Length Width Height	339 in. 114 in. 85 in.	861.06 cm 289.56 cm 215.9 cm
BOWL DIMENSIONS: Length Width Height	103 in. 97.5 in. 53.5 in.	261.62 cm 247.65 cm 135.89 cm
WEIGHT: (empty)	13,040 lbs.	5,915 kg
CUTTING WIDTH:	97.5 in.	247.65 cm
GROUND CLEARANCE:	15 in.	38.1 cm
PAYLOAD WEIGHT (@2,250 lb./yd.)	33,250 lb. yd ³	19726.4 kg/m ³
BLADE: 3 pc. Center Corner	1 x 13 x 54 in. 7/8 x 8 x 22 in.	2.54 x 33.02 x 137.16 cm 2.22 x 20.32 x 55.88 cm
CYLINDERS: Apron Lift Pushoff	Two (4 x 13) in. Two (5 x 16) in. One (4.5 x 54) in.	
HORSEPOWER REQUIREMENTS: Single (Tractor) Single (Dozer)	200 - 450 hp 149 - 336+ kw	

ASHLAND SCRAPERS

Maintenance Check list

1. Grease all zerks.
 - a) Every 8 hours of operation.
 - b) See Lubrication Points section on next page.
2. Greasing the hubs.
 - a) Re-pack wheel bearings after 300 hrs of operation.
 - b) Completely clean grease out of hub and bearings every 1200 hours of operation.
3. Check tire pressure.
 - a) See Tire Pressure Chart.
4. Check all pins for signs of wear.
 - a) Daily
5. Check wheel lug nut torque.
 - a) After first 2 hours of operation.
 - b) Recheck daily for next 2 weeks.
 - c) Tighten wheel lug nuts in a star pattern.
 - d) Torque wheel lug nuts (See Torque Specifications).
6. Check and retighten all bolts.
 - a) After initial 10 hours of use.
 - b) Again after 50 hours of use.
 - c) See Torque Specifications.
7. Inspect cutting edges.
 - a) Daily
 - b) Replace cutting edges when center blade has been worn to approximately 6" and side edges worn to approximately 4".



CAUTION! Failure to replace worn cutting edges may result in unnecessary wear to the earthmover sides and floor.

Note: Please specify left or right "L" shaped cutting edges when ordering replacements. Left or right side parts are determined by viewing from rear of the scraper.

ASHLAND SCRAPERS

Lubrication Points

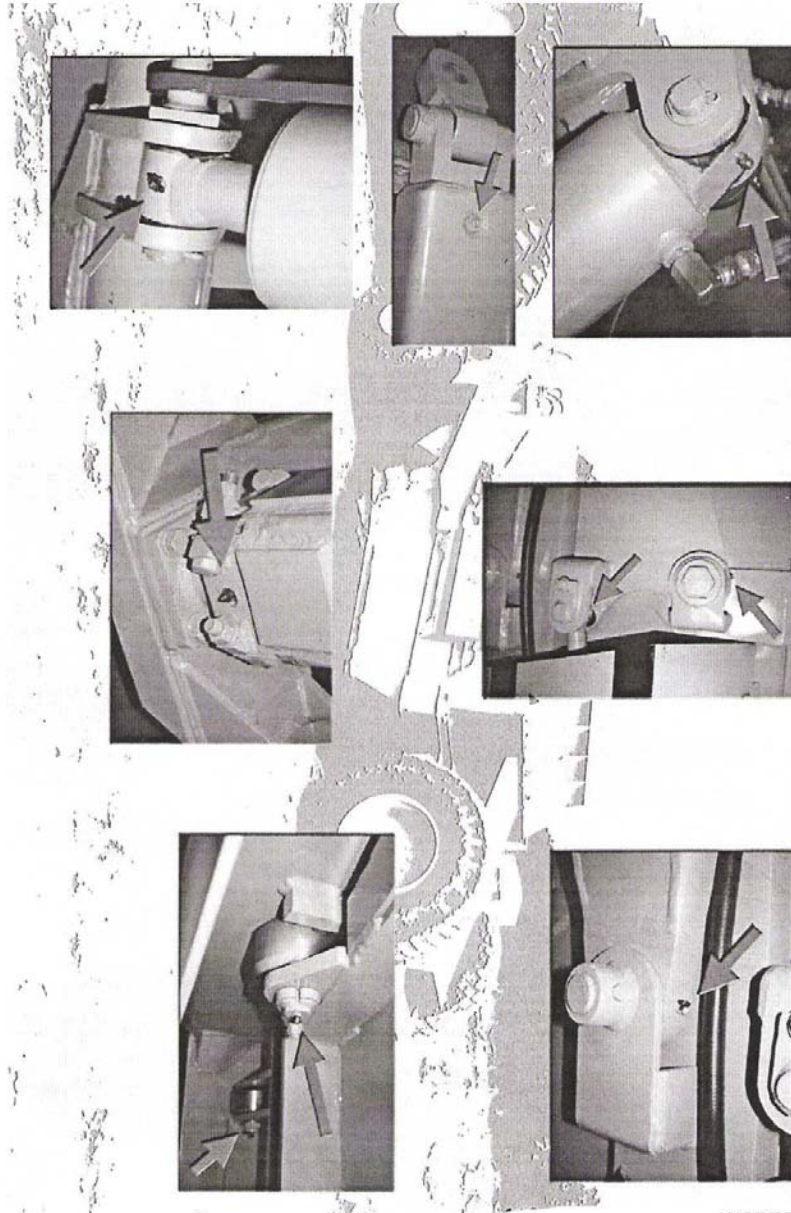

M130X250M004

1. Hitch – Horizontal and vertical pins.
2. Lift Cylinders – Rod end & Trunion; Both left & right sides.
3. Front Arm Pivot Joint – Both left & right sides.
4. Apron Cylinders – Rod clevis pin; Both left & right sides.
5. Apron Pivot Pin – Both left & right sides.
6. Hold-down Rollers – Both left & right sides.
7. Floor Rollers – Both left & right sides.
8. Tapered Rollers – Both left & right sides.

ASHLAND SCRAPERS
Pushing the Earthmover**PUSHING THE EARTHMOVER**

This scraper was designed to be pushed when equipped with the optional push-bar. However, Ashland Industries, Inc. **STRONGLY** recommends using extreme caution when pushing the earthmover to prevent any unnecessary damage.

CAUTION! The earthmover must be pushed in a straight line with a maximum of a 100 hp dozer. Do not ram or jar the earthmover while pushing and push at a constant speed.

ASHLAND SCRAPERS

Troubleshooting

Introduction

With proper care and maintenance, your Ashland Scraper will give many years of reliable service. When a situation arises where the earthmover performance is not satisfactory, this section will give some pointers on finding and correcting the problem.

Grease zerk will not take grease.

1. Grease zerk plugged.
 - a) Remove and replace grease zerk.
 2. Pin is frozen.
 - a) Remove, clean, and inspect pin.
 - b) Replace pin if necessary.
 3. Bushing grease passage is not aligned with grease zerk.
 - a) Remove, clean, inspect, and realign bushing.
 - b) Replace bushing if necessary and realign.
-

Push-off rollers do not roll.

1. The rollers need lubrication.
 - a) Check zerk hole and grease.
 - b) Remove pin, clean, inspect, and replace if necessary.
 2. The roller bushing is worn out.
 - a) Remove roller assembly and replace bushing.
 - b) See parts manual.
-

Cylinders will not hold in preset position, i.e. the cylinder creeps.

1. Seals leaking internally.
 - a) Remove and replace seal kit.
-

Machine cuts unevenly.

1. Cutting edges worn unevenly.
 - a) Replace cutting edges.
 2. Improperly inflated tires.
 - a) Check air pressure in tires.
-

ASHLAND SCRAPERS

Warranty Statement

Ashland Industries Inc. warrants each new product to be free from defects in material and workmanship. This warranty is applicable only for the normal service life expectancy of the product or components, not to exceed **six consecutive months** from the date of delivery of the new Ashland Industries product to the purchaser, or the date the product is first put into service via a rental agreement or other means, whichever occurs first.

The major components of swivel hitches used on Industrial series scrapers are warranted for three consecutive months from the date of delivery of the new Ashland Industries product to the purchaser, or the date the product is first put into service via a rental agreement or other means, whichever occurs first, except those components described below.

Genuine Ashland Industries Inc. replacement parts and components will be warranted for 30 days from date of purchase, or the remainder of the original equipment warranty period, whichever is longer.

Under no circumstances will it cover any merchandise or components thereof, which in the opinion of the company, has been subjected to misuse, unauthorized modification, alterations, an accident or if repairs have been made with parts other than those obtained through Ashland Industries Inc.

Ashland Industries Inc. in no way warrants Tires since their respective manufacturer warrants these items separately. Please call Ashland Industries Inc. to receive phone numbers of tire suppliers.

Ashland Industries Inc. in no way warrants wearable items such as cutting edges, front dolly wheel balls, socket halves, rollers, bushings, yoke hitch pins, hitch bushings, etc..

Our obligation under this warranty shall be limited to repairing or replacing, free of charge to the original purchaser, any part that, in our judgment, shall show evidence of such defect, provided further that such part shall be returned within 30 days from the date of failure to Ashland Industries Inc. routed through the dealer and distributor from whom the purchase was made, transportation charges prepaid. Upon warranty approval proper credits will be reimbursed for transportation.

This warranty shall not be interpreted to render Ashland Industries Inc. liable for injury or damages of any kind or nature to person or property. This warranty does not extend to the loss revenue, extra labor cost associated with downtime, substitute machinery, rental or for any other reason.

Except as set forth above, Ashland Industries Inc. shall have no obligation or liability of any kind on account of any of its equipment and shall not be liable for special or consequential damages. Ashland Industries Inc. make no other warranty, expressed or implied, and, specifically, Ashland Industries Inc. disclaims any implied warrant or merchantability or fitness for a particular purpose. Some states or provinces do not permit limitations or exclusions of implied warranties or incidental or consequential damages, so the limitations or exclusion in this warranty may not apply.

This warranty is subject to any existing conditions of supply which may direct affect our ability to obtain materials or manufacture replacement parts.

Ashland Industries Inc. reserves the right to make improvements in design or changes in specifications at any time, without incurring any obligation to owners of units previously sold.

No one is authorized to alter, Modify or enlarge this warranty nor the exclusion, limitations and reservations.

Warranty Department