

# ***Ashland*** **INDUSTRIES, INC.™**



## L-9, L-10 PARTS MANUAL

Version 3-03

Ashland Industries Inc.  
1115 Rail Drive  
P.O. Box 717  
Ashland, WI. 54806  
Ph: 877-634-4622 *Toll Free*  
Ph: 715-682-4622  
Fx: 715-682-9717  
[www.ashlandind.com](http://www.ashlandind.com)



### HOW TO ORDER PARTS:

#### IMPORTANT

Parts must be ordered through your local authorized ASHLAND dealer.

Be sure to state MODEL and SERIAL NUMBER of your machine, PART NUMBER, DESCRIPTION and QUANTITY needed.

Unless this is done, we cannot provide prompt service or assure shipment of the correct parts.



Ashland Industries weldable replacement parts are available to rebuild, modify or update your scraper to current factory specifications.

### INDEX

PAGE NO.	
3.	Safety Guidelines
4.	Assembly Instructions
5.	Operating Instructions
6.	Front Frame, Pole & Axle
7.	Rear Frame & Moldboard
8.	Hydraulic Cylinder
9.	Wheel, Hub, & Spindle
10.	Warranty Statement



## SAFETY SIGNAL WORDS

*Note the use of the signal words DANGER, WARNING and CAUTION with the safety messages. The appropriate signal word for each has been selected using the following guidelines:*

**DANGER:** Indicates an imminently hazardous situation that, if not avoided, will result in death or serious injury. This signal word is to be limited to the most extreme situations typically for machine components which, for functional purposes, cannot be guarded.



**WARNING:** Indicates a potentially hazardous situation that, if not avoided, could result in death or serious injury, and includes hazards that are exposed when guards are removed. It may also be used to alert against unsafe practices.



**CAUTION:** Indicates a potentially hazardous situation that, if not avoided, may result in minor or moderate injury. It may also be used to alert against unsafe practices.



## GENERAL SAFETY GUIDELINES

Safety of the operator is one of the main concerns in designing and developing a new piece of equipment. Designers and manufacturers build in as many safety features as possible. However, every year many accidents occur which could have been avoided by a few seconds of thought and a more careful approach to handling equipment. You, the operator, can avoid many accidents by observing the following precautions in this section. To avoid personal injury, study the following precautions and insist those working with you, or for you, follow them.

Replace any CAUTION, WARNING, DANGER or instruction safety decal that is not readable or is missing. Location of such decals is indicated in this booklet.

Do not attempt to operate this equipment under the influence of drugs or alcohol.

Review the safety instructions with all users annually.

This equipment is dangerous to children and persons unfamiliar with its operation. The operator should be a responsible adult familiar with farm machinery and trained in this equipment's operations. Do not allow persons to operate or assemble this unit until they have read this manual and have developed a thorough understanding of the safety precautions and of how it works.

To prevent injury or death, use a tractor equipped with a Roll Over Protective System (ROPS). Do not paint over, remove or deface any safety signs or warning decals on your equipment. Observe all safety signs and practice the instructions on them.

Never exceed the limits of a piece of machinery. If its ability to do a job, or to do so safely, is in question - DON'T TRY IT.

## ASSEMBLY INSTRUCTIONS FOR MODEL L-9, L-10 LANDLEVELER

1. Pack all wheel bearings with good quality wheel bearing grease and assemble bearings, seals, and hubs to axle spindles. Tighten adjusting nut, then loosen one or two castellations. Install cotter pin and hub cap.
2. Mount tires on rims and inflate to 35 p.s.i. Assemble tires and wheels to hubs of rear frame section and front pole.
3. Remove cast socket halves from gooseneck post and place around ball swivel and insert back into post. Be sure the socket half with the grease hole is to the rear of the post. Secure with 5/8" x 3 1/2" bolts. Install long shank grease fitting.
4. Roll front axle assembly under gooseneck and insert shank of ball into the hole on the pole top. Tighten nut securely on shank of ball swivel.
5. Connect rear frame section to front frame section using 1 1/2" x 6" pins. Lock pins in position using 1/2" x 1" capscrews.
6. Raise frame and slide moldboard under. Connect moldboard to frame brackets using 3/4" x 2 1/2" bolts, flat washers and lock washers at the bottom. Install the adjustable tilt brackets to the mold board using the 1/2" x 2 1/2" bolts and lockwashers. Install 1/2" x 2 1/2" bolts into the desired hole setting on tilt bracket and fasten to frame bracket.
7. Install end plates to moldboard using 3/4" x 1 1/2" bolts and 1/2" x 1 1/2" into the desired hole setting to keep bottom of plate level.
8. Connect one end of end plate brace to frame with 5/8" x 2" bolt. Connect opposite end to end plate with 5/8" x 1 1/2" bolt.
9. Install the depth gauge pointer to the rear frame cross members with the pointer facing forward and downward using 3/8" x 1" bolts. After the leveler is actuated with the hydraulic system a dark marking should be made on the quadrant to align the pointer with the blade at ground level.
10. Install the hydraulic cylinder with the piston rods to the rear. Secure the pins with the clip pins provided. Install the 3/8" 90 ° swivel adapters into the cylinder ports.
11. Install the 1/2" x 24" hydraulic hoses to the cylinders and oil lines, making sure the hoses from the rear cylinder ports are connected to the same line.
12. Connect land leveler to tractor hydraulic system and raise and lower the leveler several times to the extreme limits of the cylinders to remove all air which may be trapped in the lines.
13. With the leveler in a partially raised position and over a level surface, the distance from the floor to each end of the blade should be equal. Adjustment, if necessary is made at the slotted holes at each end of the moldboard where attached to the frame brackets.
14. Retighten all bolts after a few days of operation

# OPERATING INSTRUCTIONS FOR ASHLAND LAND LEVELER

## Model L-9, L-10

Land forming is becoming more and more important with each passing year to obtain increased yields per acre. By planing your fields, you are able to eliminate wet spots and low areas, thereby enabling earlier seed bed preparation, elimination of drowning out your crop, proper cultivation during early growth, and assured harvest of your crop at the proper time.

Land leveling permits faster travel speeds of equipment, which is very important, especially in harvesting when getting the crop off while the weather is suitable can often mean the difference between profit or loss.

Ashland Land Levelers are designed for maximum leveling effectiveness with a minimum of power and expense. With proper location of blade on the long rigid box frame, positive leveling action is obtained which is difficult to maintain in competitive makes of machines using numerous pins and linkages to control the action of the blade.

By its very simple design and construction, the Ashland Land Leveler requires very little operating skill. However, the following procedure should aid the operator just beginning to level

When the land leveler is being set up, care should be taken that the blade is level with the rear wheels. This should be checked before the unit goes out into the field. The unit should be run over a flat slab of concrete and with the blade in a partially raised position. A measurement should be made at each end of the blade and adjusted accordingly. The measurement should be the same on each side. The adjustment is made at the slotted hole in the moldboard where attached to the frame standard. With the land leveler in ground level position, the indicator should be either bent or a marking made accordingly to show level position on the indicator.

The field to be leveled should be plowed and disked to give your Ashland Land Leveler the effectiveness which it is designed for. The land leveler will drag the worked up ground off the high spots in your field and deposit it in the low spots.

If the field to be leveled has never been leveled and certain areas are quite irregular, it will be advantageous to work over these small areas first. In doing so, it will be necessary for the operator to control the blade with the hydraulic control to obtain the most efficient use of the machine. Due to the length of the machine, the depth of cut will increase automatically when traveling over high spots or rises in the field and generally it will be necessary for the operator to raise the blade slightly depending on how large a tractor is being used. When traveling through a low area or dip in the field, the load in front of the moldboard will empty. Some operators feel this should not occur, however, this shows that dirt is being deposited in the low area which is the primary purpose of the land leveling.

In areas of severe irregularity, the above operation should be repeated until the desired contour of the land is obtained. The entire field should then be gone over one or more times as desired. Once your fields have been leveled, you will find it necessary to repeat the planing operation the following year because the dirt deposited in the low areas will tend to settle, therefore repeated operation is necessary.

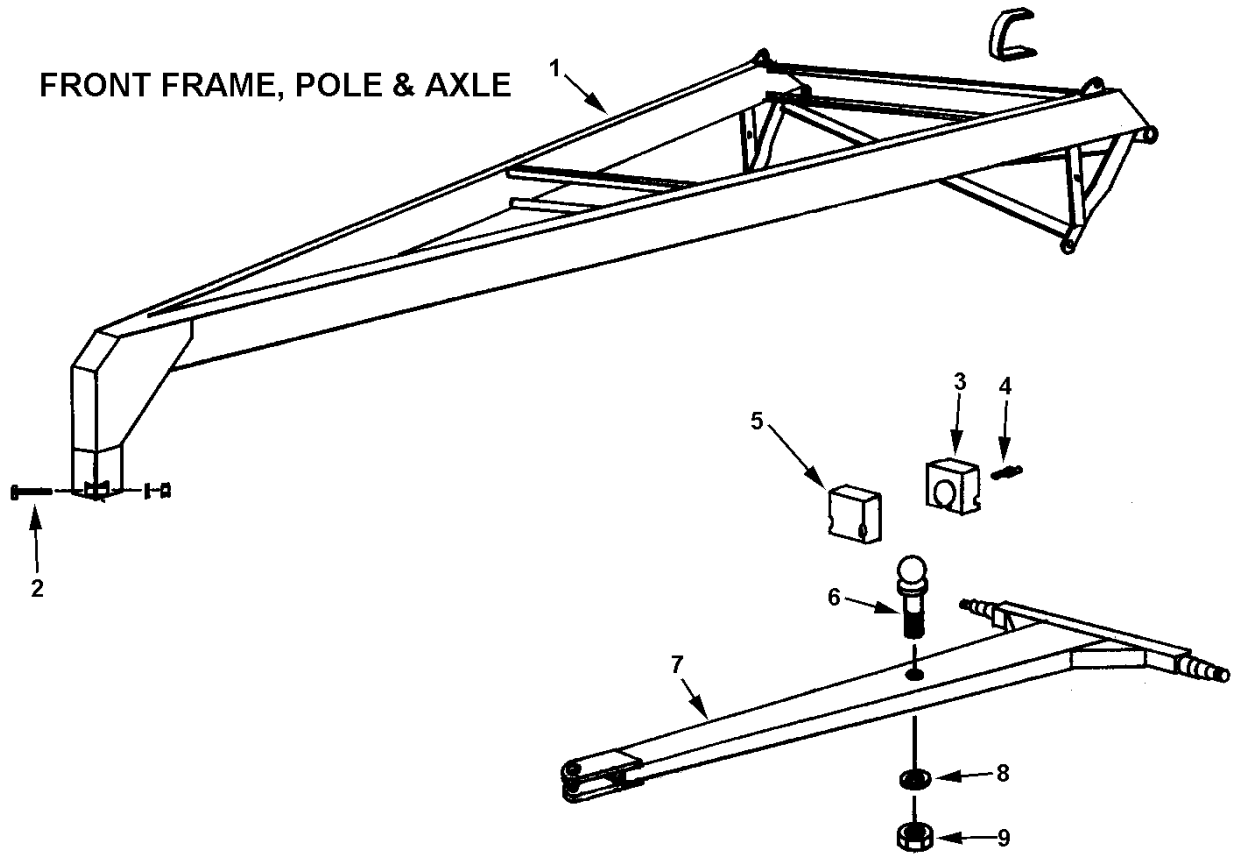

L9-10-front-frame

KEY NO.	PART NO.	DESCRIPTION
1	A901	Front frame section
2		Bolt, 5/8" NC x 3-1/2" w/ nut & lockwasher
3	A30005	Cast socket half (rear, w/ zerk hole)
4	A2206	Zerk. 1/8" NPT w/ long straight shank
5	A30004	Cast socket half (front)
6	A2203A	Ball swivel, 1-1/4" NF thread
7	A902A	Pole and axle
8		Lockwasher, 1-1/4"
9		Nut, 1-1/4" NF

## REAR FRAME & MOLDBOARD

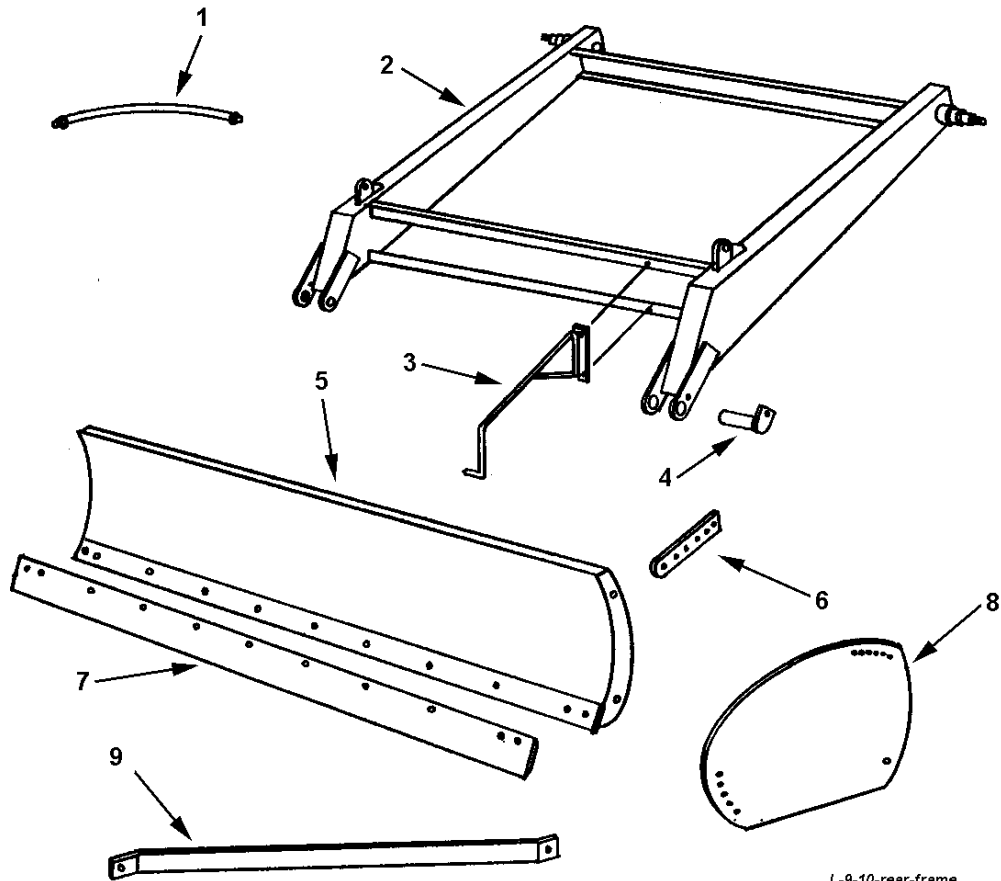

KEY NO.	PART NO.	DESCRIPTION
1	A45H06	Hydraulic hose, 1/2" x 24" (4 req'd)
2	A906	Rear frame section
3	A908	Depth gauge pointer
4	A911	Pin, 1-1/2" x 6" with grease hole (uses 1/2 x 1" NC capscrew w/ lockwasher)
5	A904	Moldboard assembly, 9 ft.
	A913	Moldboard assembly, 10 ft.
6	A907	Tilt Bracket
7	A905	Cutting edge, 9 ft.
	A10S02	Cutting edge, 10 ft.
8	A910	Plow Bolt, 1/2" NC x 1-3/4", (12 req'd 10ft or 11 req'd 9 ft.) Moldboard end plate (right and left same) (uses 3/4" x 1-1/2" bolt at bottom rear and 1/2" by 1-1/2" bolt at top)
9	A909	End plate brace for 9 ft. moldboard (uses 5/8" x 2" bolt at frame and 5/8" x 1-1/2" at end plate)
	A914	End plate brace for 10 ft. moldboard

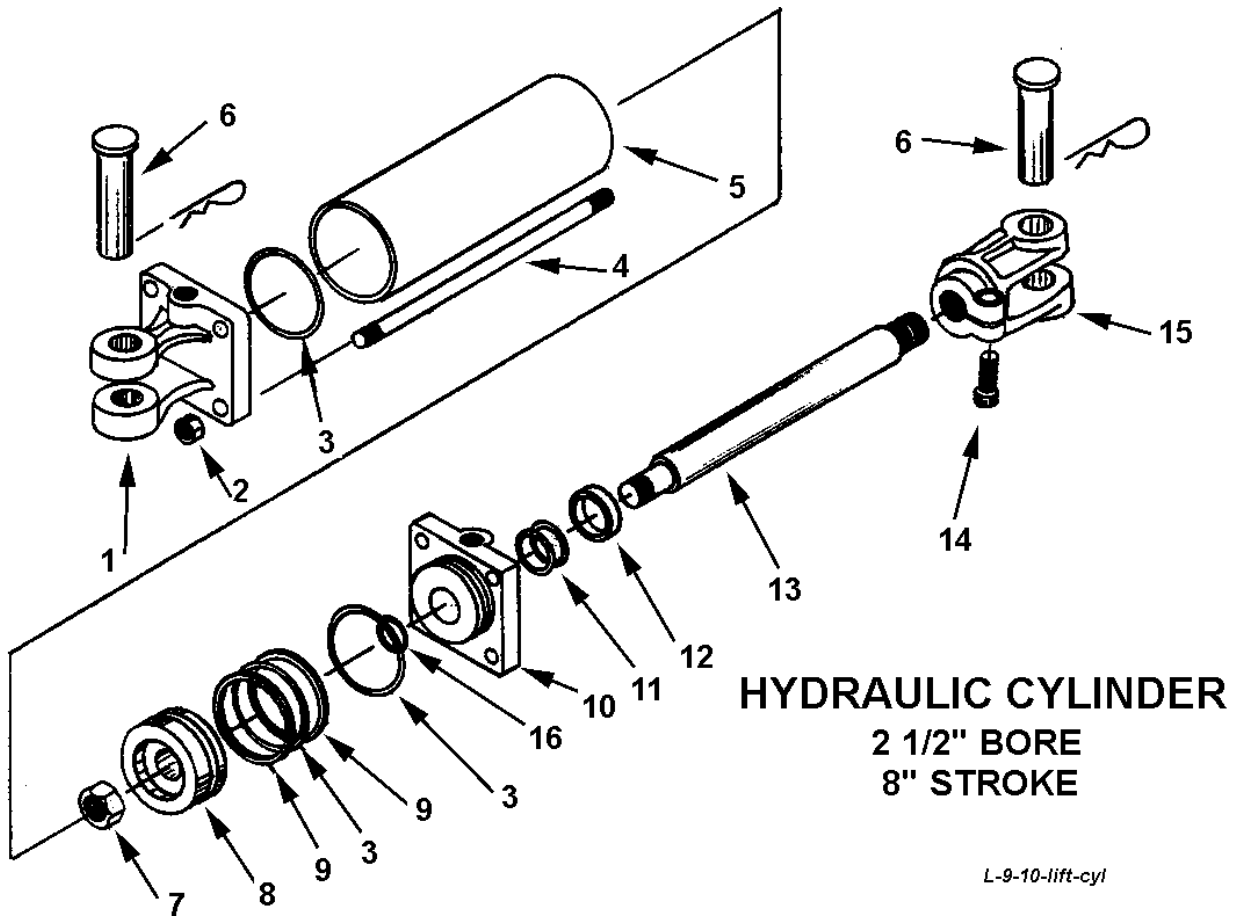

CYL. # A258-DA

KEY NO.	PART NO.	DESCRIPTION
1	A9H15	Base end clevis
2		Nut, 3/8" NC
3	A22H22	O-ring, 2-1/2" OD x 3/16"
4	A9H16	Tie rod
5	A9H17	Barrel, 2-1/2" ID
6	A912	Pin, 1" dia., w/ clip pin
7	A9H18	Piston nut
8	A9H19	Piston, 2-1/2" dia.
9	A22H21	Back up washer, 2-1/2" OD
10	A9H20	Head gland
11	A9H21A	Shaft seal, 1-1/16"
12	A9H22A	Wiper seal, 1-1/16"
13	A9H23A	Shaft, 1-1/16"
14		Capscrew, 5/16" NC socket head
15	A9H24	Clevis end
16	A9H25	Piston gasket
	A9H26	Packing kit containing:
		3 A22H22    1 A9H21    2 A22H21
		1 A9H22    1 A9H25



## WHEEL, HUB & SPINDLE

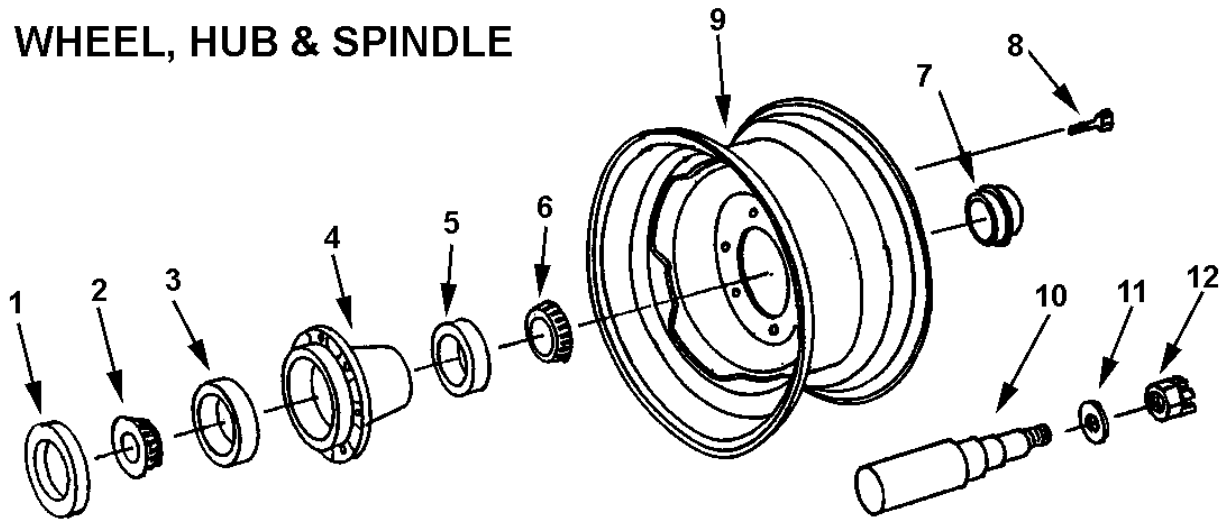

L-9-10-wheel

KEY NO.	PART NO.	DESCRIPTION
1	A2229	Grease seal
2	A2230	Bearing cone (inner)
3	A2231	Bearing cup (inner)
4	A2232	Hub, less bearings
5	A2233	Bearing cup (outer)
6	A2234	Bearing cone (outer)
7	A2235	Hub cap
8	A2236	Wheel bolt
9	A3319	Wheel, 15" x 6"
10	A2238	Spindle
11	A2239	Washer, special 7/8" flat
12		Nut, 7/8" NF castellated Cotterpin, 3/16" x 1-1/2"

# Limited Warranty Statement

Ashland Industries Inc. warrants each new product to be free from defects in material and workmanship. This warranty is applicable only for the normal service life expectancy of the product or components, not to exceed six consecutive months from the date of delivery of the new Ashland Industries product to the original purchaser, or the date the product is first put into service via a rental agreement or other means, whichever occurs first.

Genuine Ashland Industries Inc. replacement parts and components will be warranted for 30 days from date of purchase, or the remainder of the original equipment warranty period, whichever is longer.

Under no circumstances will it cover any merchandise or components thereof, which in the opinion of the company, has been subjected to misuse, unauthorized modification, alterations, an accident or if repairs have been made with parts other than those obtained through Ashland Industries Inc.

Ashland Industries Inc. in no way warrants Tires since these items are warranted separately by their respective manufacturer. Please call Ashland Industries Inc. to receive phone numbers of tire suppliers.

Ashland Industries Inc. in no way warrants wearable items such as cutting edges, front dolly wheel balls, socket halves.

Our obligation under this warranty shall be limited to repairing or replacing, free of charge to the original purchaser, any part that, in our judgement, shall show evidence of such defect, provided further that such part shall be returned within 30 days from the date of failure to Ashland Industries Inc. routed through the dealer and distributor from whom the purchase was made, transportation charges prepaid. Upon warranty approval proper credits will be reimbursed for transportation.

This warranty shall not be interpreted to render Ashland Industries Inc. liable for injury or damages of any kind or nature to person or property. This warranty does not extend to the loss revenue, extra labor cost associated with downtime, substitute machinery, rental or for any other reason.

Except as set forth above, Ashland Industries Inc. shall have no obligation or liability of any kind on account of any of its equipment and shall not be liable for special or consequential damages. Ashland Industries Inc. make no other warranty, expressed or implied, and, specifically, Ashland Industries Inc. disclaims any implied warrant or merchantability or fitness for a particular purpose. Some states or provinces do not permit limitations or exclusions of implied warranties or incidental or consequential damages, so the limitations or exclusion in this warranty may not apply.

This warranty is subject to any existing conditions of supply which may direct affect our ability to obtain materials or manufacture replacement parts.

Ashland Industries Inc. reserves the right to make improvements in design or changes in specifications at any time, without incurring any obligation to owners of units previously sold

No one is authorized to alter, modify or enlarge this warranty nor the exclusion, limitations and reservations.

Ashland Industries Inc.  
Warranty Department