

Ashland **INDUSTRIES, INC.™**



Model 35 PARTS MANUAL

Version 30304

Ashland Industries Inc.
1115 Rail Drive
P.O. Box 717
Ashland, WI. 54806
Ph: 877-634-4622 *Toll Free*
Ph: 715-682-4622
Fx: 715-682-9717
www.ashlandind.com



HOW TO ORDER PARTS:

IMPORTANT

Parts must be ordered through your local authorized ASHLAND dealer. Be sure to state MODEL and SERIAL NUMBER of your machine, PART NUMBER, DESCRIPTION and QUANTITY needed. Unless this is done, we cannot provide prompt service or assure shipment of the correct parts.



Ashland Industries weldable replacement parts are available to rebuild, modify or update your scraper to current factory specifications.

INDEX

Page 3.	Operator and Maintenance Instructions
Page 4.	Safety Guidelines
Page 5.	Assembly Instructions
Page 6.	Frame Assembly
Page 7.	Pole, Axle and Wheel Assembly
Page 8.	Bucket & Apron Assembly
Page 9.	Actuating Assembly
Page 10.	Hydraulic Cylinder 3 1/2" x 16"
Page 11.	Hydraulic Cylinder (Opt. Hi-Press) 2 1/2" x 16"
Page 12.	Warranty Statement

OPERATORS AND MAINTENANCE INSTRUCTIONS

This scraper is a durable piece of equipment and with proper care will yield many years of trouble free operation. The scraper requires a power source with TWO 4 way (double acting) hydraulic control valves.

The scraper should be greased at all points where grease fittings are provided. Connect hydraulic hoses to the tractor and retract lift cylinders to **REMOVE TRANSPORT LOCK PINS** (point A), then extend and retract all cylinders several times to force out any air from the hydraulic cylinders and lines. Check the oil levels in the tractor hydraulic system and add to maintain the proper level. Care should be used when adding oil or when disconnecting any oil line to keep all dirt out of the oil as dirt is a major factor in the failure of hydraulic components.

When the scraper is placed into operation, the operator will have to "feel out" the amount of depth of cut to obtain maximum loading efficiency. This is usually accomplished by taking a lesser and more uniform cut; however, some soil conditions such as loose sand may require a "pumping action" obtained by taking successive deep cuts and lifting out of cut as the tractor begins to lose power or traction.

1. After 10 hours work, all bolts should be checked and tightened if necessary.
2. Every 10 hours all grease fittings should be lubricated.
3. After 50 hours work, all bolts should be rechecked and tightened if necessary. Check wheel bearings and adjust if necessary.
4. After 300 hours work, clean and repack wheel bearings and replace, if necessary, cutting edges, worn pins, etc.



SAFETY SIGNAL WORDS

Note the use of the signal words *DANGER*, *WARNING* and *CAUTION* with the safety messages. The appropriate signal word for each has been selected using the following guidelines:

DANGER: Indicates an imminently hazardous situation that, if not avoided, will result in death or serious injury. This signal word is to be limited to the most extreme situations typically for machine components which, for functional purposes, cannot be guarded.

WARNING: Indicates a potentially hazardous situation that, if not avoided, could result in death or serious injury, and includes hazards that are exposed when guards are removed. It may also be used to alert against unsafe practices.

CAUTION: Indicates a potentially hazardous situation that, if not avoided, may result in minor or moderate injury. It may also be used to alert against unsafe practices.



GENERAL SAFETY GUIDELINES

Safety of the operator is one of the main concerns in designing and developing a new piece of equipment. Designers and manufacturers build in as many safety features as possible. However, every year many accidents occur which could have been avoided by a few seconds of thought and a more careful approach to handling equipment. You, the operator, can avoid many accidents by observing the following precautions in this section. To avoid personal injury, study the following precautions and insist those working with you, or for you, follow them.

Replace any CAUTION, WARNING, DANGER or instruction safety decal that is not readable or is missing. Location of such decals is indicated in this booklet.

Do not attempt to operate this equipment under the influence of drugs or alcohol.

Review the safety instructions with all users annually.

This equipment is dangerous to children and persons unfamiliar with its operation. The operator should be a responsible adult familiar with farm machinery and trained in this equipment's operations. **Do not allow persons to operate or assemble this unit until they have read this manual and have developed a thorough understanding of the safety precautions and of how it works.**

To prevent injury or death, use a tractor equipped with a Roll Over Protective System (ROPS). Do not paint over, remove or deface any safety signs or warning decals on your equipment. Observe all safety signs and practice the instructions on them.

Never exceed the limits of a piece of machinery. If its ability to do a job, or to do so safely, is in question - **DON'T TRY IT.**

ASSEMBLY INSTRUCTIONS FOR MODEL 35 SCRAPER

1. A suitable hoist or lift should be available for assembly.
2. Pack wheel bearings with grease and install hubs to axle spindles.
3. Raise actuating frame over bucket and lower into place so that the holes in the arms of the actuating frame align with the rear hole on each side of the bucket. Insert 1 ¼" x 2-3/8" pin (with tab type head) from the inside of the bucket. Secure with 5/8" x 1 ¼" NF bolt through bucket side with the locking nut to the outside.
4. Connect actuating arm bars into the front holes in the bucket. In doing so, be sure that the cast roller on the opposite end of the actuating arm is in the up position and facing inward. Insert 1 ¼" x 2-3/8" pin (with tab type head) from the inside of the bucket. Secure with 5/8" x 1 ¼" bolt through the bucket side with the lock nut to the outside.
5. Connect a short chain from the cutting edge to the cross pipe of the actuating frame, then raise the bucket and actuating frame assembly over the main frame and lower until the front of the actuating frame can be connected to the 1 ½" ID bearing on each side of the main frame. Secure with 1 ½" x 5-5/8" pins on each side. Lock these pins in place by turning the pin until the hole in the head aligns with the threaded hole in the actuating frame, then secure with ½" x 1" NC capscrew and lockwasher.
6. Lift front end of actuating arm and connect to the brackets on the front frame cross-member using the 1 ¼" x 3-5/8" pins. Secure with ¼" x 2" cotter pin.
7. Raise the apron assembly over the scraper and lower into position so that the holes in the arms of the apron align with the holes in the bucket sides. Insert the 1-1/4" to 1" shoulder pin through the apron arms and into the bucket. Install lock nut inside the bucket and tighten securely.
8. Install hydraulic cylinders to main frame and actuating frame with rod end to actuating frame. Be sure the grease hole in the rod end is facing up. Use 1" x 4 ¼" pin at the base of the cylinder. Secure with 3/16" x 1 ½" cotter pins. Use 1" x 5-5/8" pin at the rod end of the cylinder. Secure with 1" x ½" NC capscrew and lockwasher.
9. Install 3/8" 90° swivel adapters into front port on each cylinder. Tighten so that the hose connection faces the rear.
10. Connect a 3/8" x 18" hose from the rear port of each cylinder to one of the pipe lines on the rear cross frame. Be sure both hoses from the rear ports are connected to the same pipe line. Use a 3/8" straight adapter at the pipe line.
11. Connect a 3/8" x 33" hose from the front port of each cylinder to the remaining pipe line on the rear cross frame.
12. Raise rear of frame and install wheels to hubs. Also install wheels to front axle assembly on 35D model.
13. 35D: Raise front of frame and remove the two 5/8" x 4" bolts which hold the cast socket halves inside the gooseneck. Remove the cast socket halves.
14. 35D: Roll the pole and axle assembly directly under the gooseneck and place the cast socket halves around the ball swivel on axle. Lower the frame into place so that the socket halves seat into the gooseneck. (If necessary, clamp halves together with C-clamp while inserting into gooseneck.) Replace 5/8" x 4" bolts and tighten securely. Install long shank grease fitting into hole in back side of gooseneck.
15. Install all the grease fittings and grease liberally.
16. If available, place assembled scraper on level floor or pavement and measure the distance from the cutting edge to floor, on both left and right sides, and then adjust axle spindle to obtain equal distance on both sides.

FRAME ASSEMBLY

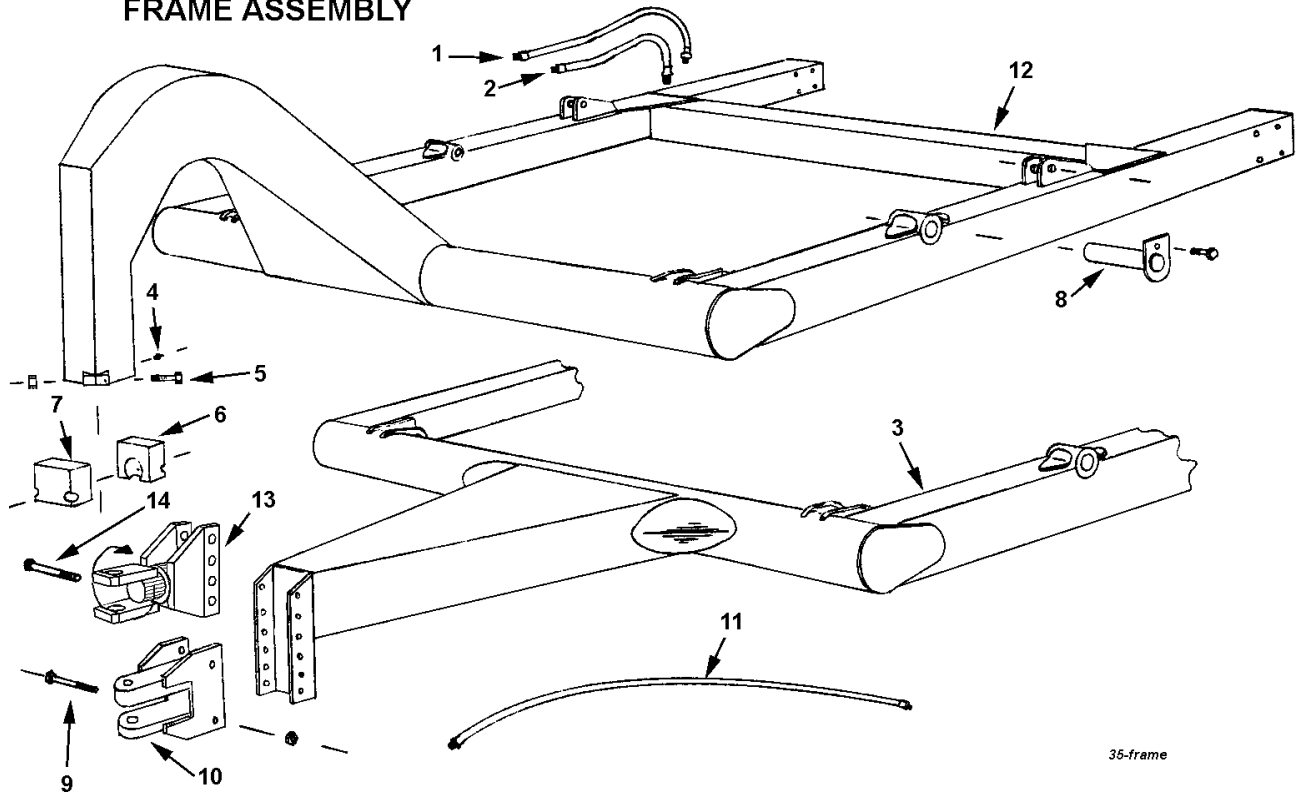

KEY NO.	PART NO.	DESCRIPTION
1	A22H02	Hydraulic hose, 3/8" x 33"
2	A450H01	Hydraulic hose, 3/8" x 18"
	A22H03	Swivel adapter, 3/8" x 90°
	A22H04	Swivel adapter, 3/8" straight
3	A3502	Frame, two wheel Model S
4	A2206	Zerk fitting, 1/8" NPT straight long
5		Bolt, 5/8" x 4" NC w/ nut & LW
6	A30005	Cast socket half, rear w/ zerk hole, up to s/n 14759
	A40005	Cast socket half, rear w/ zerk hole, s/n 14779 & up
7	A30004	Cast socket half, front, up to s/n 14759
	A40004	Cast socket half, front, s/n 14779 & up
8	A2502	Pin, 1-1/2" x 5-3/4"
9		Capscrew, 1/2" x 1" NC w/ LW
		Bolt, 3/4" x 6" NC w/ nut & LW
10	A4523	Hitch
11		Connecting hose, 1/2" x 96" or 1/2" x 60" (optional)
12	A3501	Frame, four wheel Model D
13	A5004	Swivel hitch
14		Bolt, 1" x 6-1/2" NC w/ nut & LW
***	A022977-2	Hitch, Tractor 3 point, Category 2
***	A022977-3	Hitch, Tractor 3 point, Category 3

POLE, AXLE & WHEEL ASSEMBLY

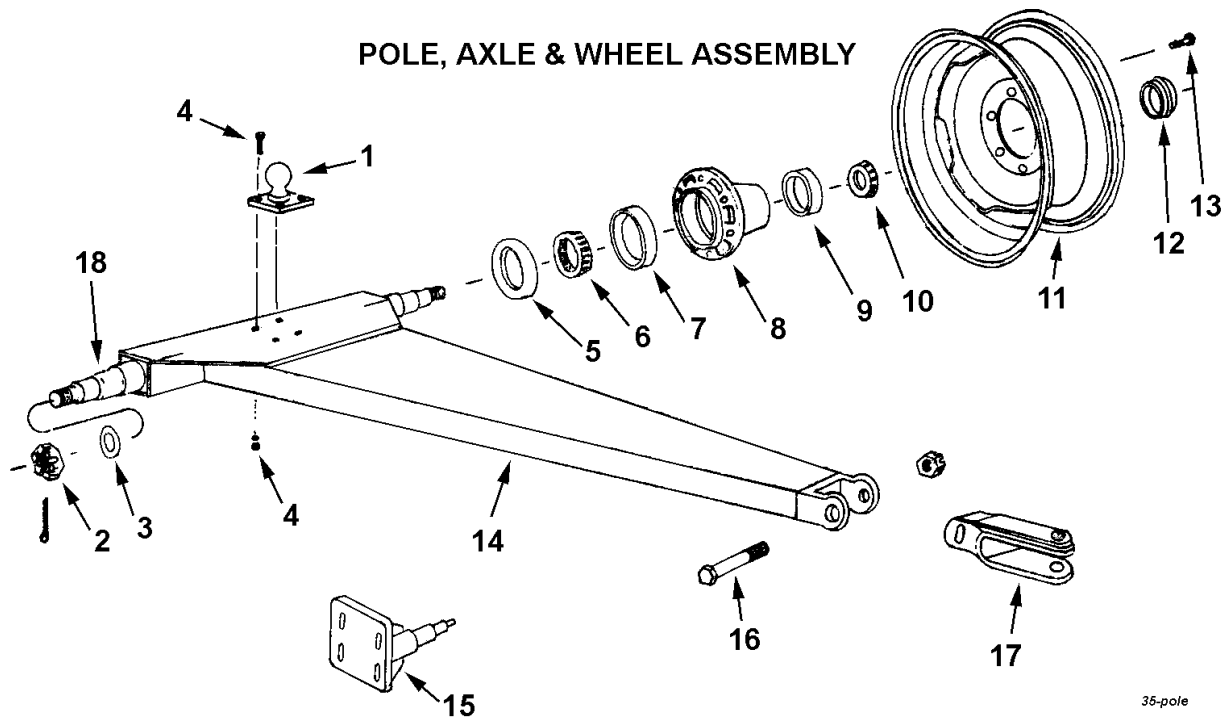

38-pole

KEY NO.	PART NO.	DESCRIPTION
1	A2203A	Ball swivel, up to s/n 14759
	A40006	Ball swivel, s/n 14779 & up
2		Nut, 7/8" castellated, Cotter pin, 5/32" x 1-1/4"
3	A2239	Washer, special 7/8" flat
4		Bolt, 3/4" x 2-1/2" NC w/ nut & lockwasher
5	A2229	Grease seal up to s/n 14759 on rear axle (CR 22870)
		Grease seal up to s/n 20037 on pole axle
	A2229A	Grease seal, s/n 14779 & up on rear axle (CR 20079)
		Grease seal, s/n 20038 & up on pole axle
6	A2230	Bearing cone, inner, up to s/n 14759 on rear axle (Timken 342A)
		Bearing cone, inner, up to s/n 20037 on pole axle
	A2230A	Bearing cone, inner, s/n 14779 & up on rear axle (Timken 342S)
		Bearing cone, inner, s/n 20038 & up on pole axle
7	A2231	Bearing cup, inner (Timken 332)
8	A2232	Hub, with bearing cups
9	A2233	Bearing cup, outer (Timken 14276)
10	A2234	Bearing cone, outer (Timken 14137A)
11	A3319	Wheel, 15" x 6" drop center
12	A2235	Hub cap
13	A2236	Wheel bolt
14	A3509	Pole and Axle
15	A30022	Spindle, up to s/n 14759
	A30022A	Spindle, s/n 14779 & up
16		Bolt, 1" x 5-1/2" NF gr. 5 w/ lock nut
17	A2207	Hitch
18	A2338	Weld in spindle, s/n up to 20037
	A2238A	Weld in spindle, s/n 20038 & up

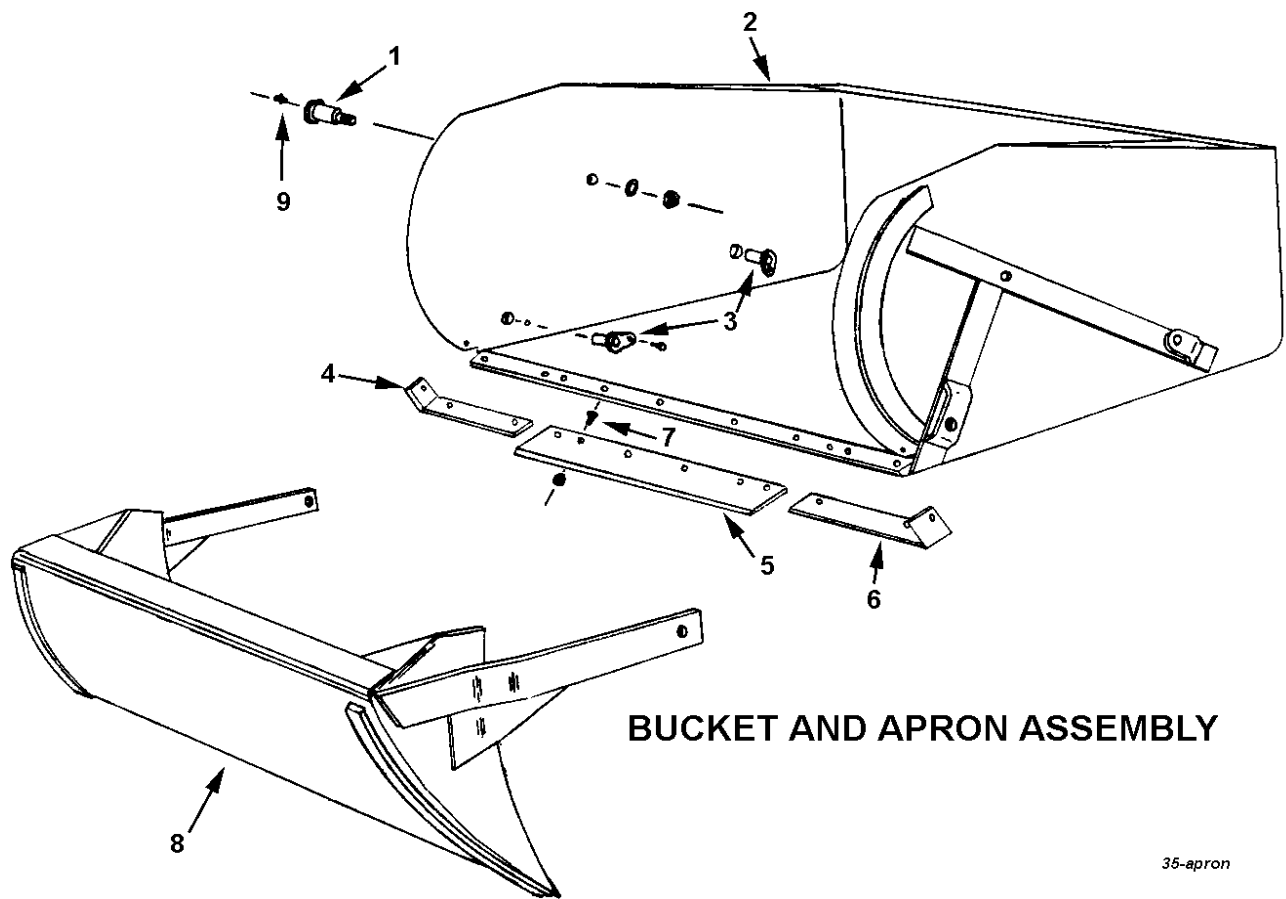

BUCKET AND APRON ASSEMBLY

35-apron

KEY NO.	PART NO.	DESCRIPTION
1	A30020	Shoulder pin, 1-1/4" to 1" NF w/ ctsk hole
2	A3503	Bucket
3	A4505	Pin, 1-1/4" x 2-3/8" w/ locking head
		Bolt, 5/8" x 1-1/4" NC w/ lock nut
4	A2224	Right cutting edge, 4"
5	A30021	Center cutting edge, 6" x 42"
6	A2221	Left cutting edge, 4"
7		Plow bolt, 1/2" x 1-3/4" w/ nut (12 req'd)
8	A3504	Apron
9		Grease fitting, 1/8" NPT std.

ACTUATING FRAME ASSEMBLY

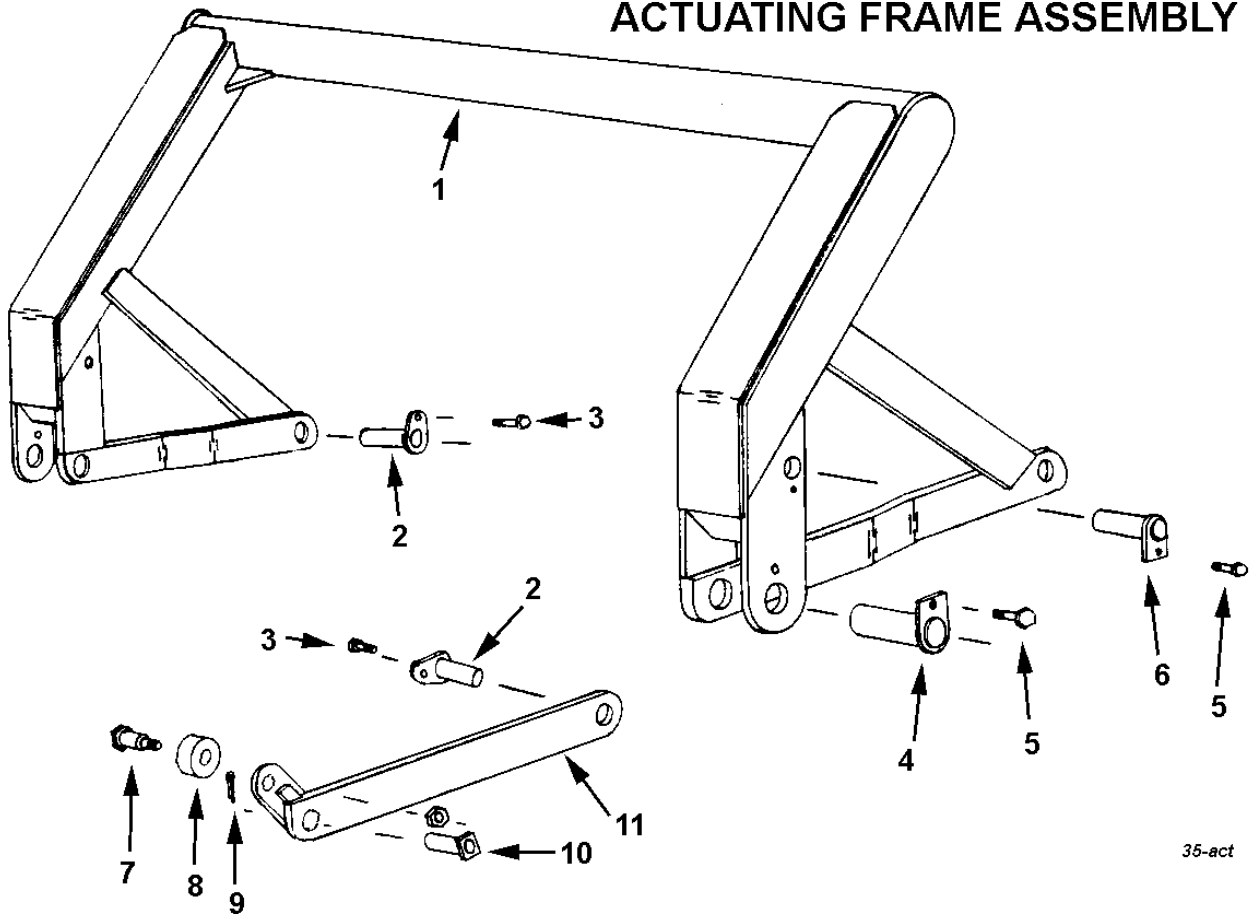

35-act

KEY NO.	PART NO.	DESCRIPTION
1	A3505	Actuating frame
2	A4505	Pin, 1-1/4" x 2-3/8" w/ locking head
3		Bolt, 5/8" x 1-1/2" NF w/ lock nut
4	A2502	Pin, 1-1/2" x 5-3/4"
5		Capscrew, 1/2" x 1" NC
6	A3318	Pin, 1" x 5-5/8"
7	A30003	Shoulder pin, 2-1/2" shoulder 1-1/4" to 1" NF
		Nut, 1" NFw/ nylon insert
8	A30002	Roller
9		Cotter pin, 1/4" x 2"
10	A3506	Pin, 1-1/4" x 3-5/8" w/ sq. head
11	A3507	Actuating arm, right
	A3508	Actuating arm, left

HYDRAULIC CYLINDER
3-1/2" BORE X 16" STROKE
(STANDARD)

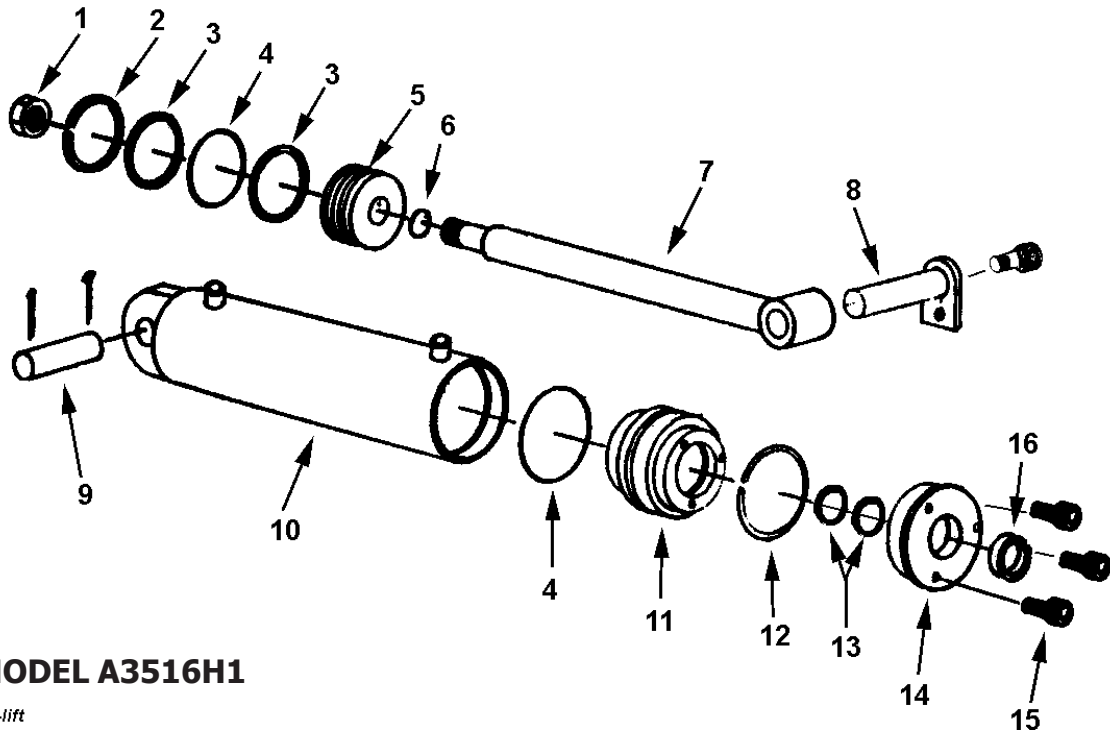

MODEL A3516H1

35-cyl-lift

KEY NO.	PART NO.	DESCRIPTION
1	A22H05	Piston nut, 3/4" NF
2	A22H06	Cast iron ring, 3-1/2" OD
3	A22H07	Back up washer, 3-1/2" OD
4	A22H08	O-ring seal, 3-1/2" OD x 3/16"
5	A22H09	Piston, 3-1/2"
6	A22H10A	Piston gasket, 3/4" ID
7	A22H11	Shaft, 1-1/2" dia.
8	A3318	Pin, 1" x 5-5/8" tab head
9	A2508	Pin, 1" x 3-1/4"
		Cotter pin, 3/16" x 1-1/2"
10	A22H12	Barrel assembly, 3-1/2" ID
11	A22H13	Head gland, 3-1/2"
12	A22H14	Retainer ring
13	A22H15	O-ring, 1-1/2" x 1/8"
	A22H15A	Back up washer
14	A22H16	Head cap
15	A22H18	Capscrew, 1/4" x 1"
16	A22H17	Wiper seal, 1-1/2" ID
	A22H19B	Packing kit containing:
		1 A22H06 2 A22H15 2 A22H07
		1 A22H15A 2 A22H08 1 A22H17
		1 A22H10A

HYDRAULIC CYLINDER
2-1/2" BORE X 16" STROKE
(OPTIONAL)
HIGH PRESSURE

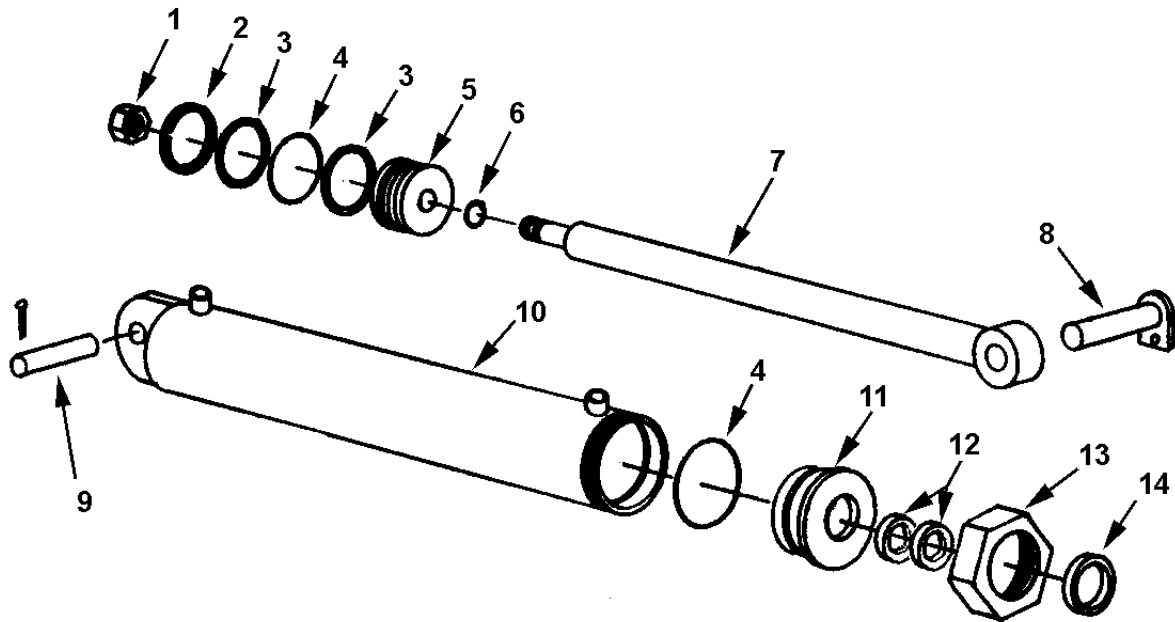

MODEL A2516H1

35-cyl-high-p

<u>KEY NO.</u>	<u>PART NO.</u>	<u>DESCRIPTION</u>
1	A22H05	Piston nut, 3/4" NF
2	A22H20	Cast iron piston ring, 2-1/2" OD
3	A22H21	Piston back up washer, 2-1/2" OD
4	A22H22	O-ring seal, 2-1/2" OD
5	A22H23	Piston, 2-1/2"
6	A22H10A	Piston gasket
7	A22H24	Shaft, 1-1/4" dia.
8	A3318	Pin, 1" x 5-5/8" tab head
9	A2508	Capscrew, 1/2" NC x 1" w/ LW Pin, 1" x 3-1/4"
10	A22H25	Barrel assembly, 2-1/2" ID
11	A22H26	Head gland
12	A22H27	O-ring
	A22H27A	Back up washer
13	A22H28	Head cap
14	A22H29	Wiper seal
	A22H30B	Packet kit containing:
		1 A22H20 2 A22H27 2 A22H21
		1 A22H29 2 A22H22 1 A22H27A
		1 A22H10A

Limited Warranty Statement

Ashland Industries Inc. warrants each new product to be free from defects in material and workmanship. This warranty is applicable only for the normal service life expectancy of the product or components, not to exceed **six consecutive months** from the date of delivery of the new Ashland Industries product to the purchaser, or the date the product is first put into service via a rental agreement or other means, whichever occurs first.

The major components of swivel hitches used on Industrial series scrapers are warranted for three consecutive months from the date of delivery of the new Ashland Industries product to the purchaser, or the date the product is first put into service via a rental agreement or other means, whichever occurs first, except those components described below.

Genuine Ashland Industries Inc. replacement parts and components will be warranted for 30 days from date of purchase, or the remainder of the original equipment warranty period, whichever is longer.

Under no circumstances will it cover any merchandise or components thereof, which in the opinion of the company, has been subjected to misuse, unauthorized modification, alterations, an accident or if repairs have been made with parts other than those obtained through Ashland Industries Inc.

Ashland Industries Inc. in no way warrants Tires since their respective manufacturer warrants these items separately. Please call Ashland Industries Inc. to receive phone numbers of tire suppliers.

Ashland Industries Inc. in no way warrants wearable items such as cutting edges, front dolly wheel balls, socket halves, rollers, bushings, yoke hitch pins, hitch bushings, etc..

Our obligation under this warranty shall be limited to repairing or replacing, free of charge to the original purchaser, any part that, in our judgement, shall show evidence of such defect, provided further that such part shall be returned within 30 days from the date of failure to Ashland Industries Inc. routed through the dealer and distributor from whom the purchase was made, transportation charges prepaid. Upon warranty approval proper credits will be reimbursed for transportation.

This warranty shall not be interpreted to render Ashland Industries Inc. liable for injury or damages of any kind or nature to person or property. This warranty does not extend to the loss revenue, extra labor cost associated with downtime, substitute machinery, rental or for any other reason.

Except as set forth above, Ashland Industries Inc. shall have no obligation or liability of any kind on account of any of its equipment and shall not be liable for special or consequential damages. Ashland Industries Inc. make no other warranty, expressed or implied, and, specifically, Ashland Industries Inc. disclaims any implied warrant or merchantability or fitness for a particular purpose. Some states or provinces do not permit limitations or exclusions of implied warranties or incidental or consequential damages, so the limitations or exclusion in this warranty may not apply.

This warranty is subject to any existing conditions of supply which may direct affect our ability to obtain materials or manufacture replacement parts.

Ashland Industries Inc. reserves the right to make improvements in design or changes in specifications at any time, without incurring any obligation to owners of units previously sold

No one is authorized to alter, Modify or enlarge this warranty nor the exclusion, limitations and reservations.