

MODEL L-9, L-10 LAND LEVELER

HOW TO ORDER PARTS:

Be sure to state MODEL and SERIAL NO. of machine, PARTS NO., DESCRIPTION, and QUANTITY wanted.

Unless this is done, we cannot provide prompt service or assure shipment of the correct parts.

INDEX

PAGE NO.

1. Assembly Instructions
2. Operating Instructions
3. Front Frame, Pole & Axle
4. Rear Frame & Moldboard
5. Hydraulic Cylinder
6. Wheel, Hub, & Spindle

ASSEMBLY INSTRUCTIONS FOR MODEL L-9, L-10 LANDLEVELER

1. Pack all wheel bearings with good quality wheel bearing grease and assemble bearings, seals, and hubs to axle spindles. Tighten adjusting nut, then loosen one or two castellations. Install cotter pin and hub cap.
2. Mount tires on rims and inflate to 35 p.s.i. Assemble tires and wheels to hubs of rear frame section and front pole.
3. Remove cast socket halves from gooseneck post and place around ball swivel and insert back into post. Be sure the socket half with the grease hole is to the rear of the post. Secure with 5/8" x 3 1/2" bolts. Install long shank grease fitting.
4. Roll front axle assembly under gooseneck and insert shank of ball into the hole on the pole top. Tighten nut securely on shank of ball swivel.
5. Connect rear frame section to front frame section using 1 1/2" x 6" pins. Lock pins in position using 1/2" x 1" capscrews.
6. Raise frame and slide moldboard under. Connect moldboard to frame brackets using 3/4" x 2 1/2" bolts, flat washers and lock washers at the bottom. Install the adjustable tilt brackets to the mold board using the 1/2" x 2 1/2" bolts and lockwashers. Install 1/2" x 2 1/2" bolts into the desired hole setting on tilt bracket and fasten to frame bracket.
7. Install end plates to moldboard using 3/4" x 1 1/2" bolts and 1/2" x 1 1/2" into the desired hole setting to keep bottom of plate level.
8. Connect one end of end plate brace to frame with 5/8" x 2" bolt. Connect opposite end to end plate with 5/8" x 1 1/2" bolt.
9. Install the depth gauge pointer to the rear frame cross members with the pointer facing forward and downward using 3/8" x 1" bolts. After the leveler is actuated with the hydraulic system a dark marking should be made on the quadrant to align the pointer with the blade at ground level.
10. Install the hydraulic cylinder with the piston rods to the rear. Secure the pins with the clip pins provided. Install the 3/8" 90° swivel adapters into the cylinder ports.
11. Install the 1/2" x 24" hydraulic hoses to the cylinders and oil lines, making sure the hoses from the rear cylinder ports are connected to the same line.
12. Connect land leveler to tractor hydraulic system and raise and lower the leveler several times to the extreme limits of the cylinders to remove all air which may be trapped in the lines.
13. With the leveler in a partially raised position and over a level surface, the distance from the floor to each end of the blade should be equal. Adjustment, if necessary is made at the slotted holes at each end of the moldboard where attached to the frame brackets.
14. Retighten all bolts after a few days of operation

ASHLAND INDUSTRIES
P. O. BOX 717
Ashland, Wisconsin 54806

OPERATING INSTRUCTIONS FOR ASHLAND LAND LEVELER, Model L-9, L-10

Land forming is becoming more and more important with each passing year to obtain increased yields per acre. By planing your fields, you are able to eliminate wet spots and low areas, thereby enabling earlier seed bed preparation, elimination of drowning out your crop, proper cultivation during early growth, and assured harvest of your crop at the proper time.

Land leveling permits faster travel speeds of equipment, which is very important, especially in harvesting when getting the crop off while the weather is suitable can often mean the difference between profit or loss.

Ashland Land Levelers are designed for maximum leveling effectiveness with a minimum of power and expense. With proper location of blade on the long rigid box frame, positive leveling action is obtained which is difficult to maintain in competitive makes of machines using numerous pins and linkages to control the action of the blade.

By its very simple design and construction, the Ashland Land Leveler requires very little operating skill. However, the following procedure should aid the operator just beginning to level

When the land leveler is being set up, care should be taken that the blade is level with the rear wheels. This should be checked before the unit goes out into the field. The unit should be run over a flat slab of concrete and with the blade in a partially raised position. A measurement should be made at each end of the blade and adjusted accordingly. The measurement should be the same on each side. The adjustment is made at the slotted hole in the moldboard where attached to the frame standard. With the land leveler in ground level position, the indicator should be either bent or a marking made accordingly to show level position on the indicator.

The field to be leveled should be plowed and disked to give your Ashland Land Leveler the effectiveness which it is designed for. The land leveler will drag the worked up ground off the high spots in your field and deposit it in the low spots.

If the field to be leveled has never been leveled and certain areas are quite irregular, it will be advantageous to work over these small areas first. In doing so, it will be necessary for the operator to control the blade with the hydraulic control to obtain the most efficient use of the machine. Due to the length of the machine, the depth of cut will increase automatically when traveling over high spots or rises in the field and generally it will be necessary for the operator to raise the blade slightly depending on how large a tractor is being used. When traveling through a low area or dip in the field, the load in front of the moldboard will empty. Some operators feel this should not occur, however, this shows that dirt is being deposited in the low area which is the primary purpose of the land leveling.

In areas of severe irregularity, the above operation should be repeated until the desired contour of the land is obtained. The entire field should then be gone over one or more times as desired. Once your fields have been leveled, you will find it necessary to repeat the planing operation the following year because the dirt deposited in the low areas will tend to settle, therefore repeated operation is necessary.

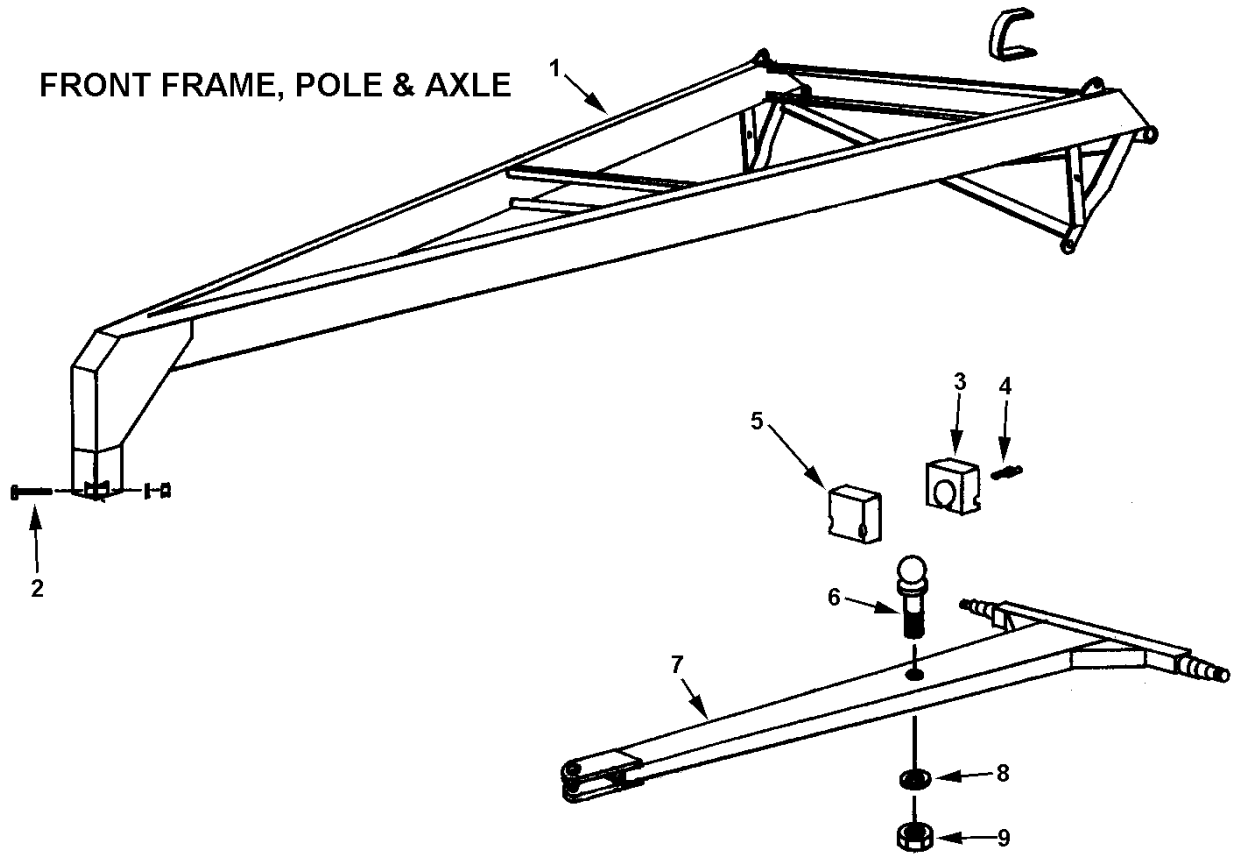

L9-10-front-frame

| KEY NO. | PART NO. | DESCRIPTION |
|---------|----------|--|
| 1 | A901 | Front frame section |
| 2 | | Bolt, 5/8" NC x 3-1/2" w/ nut & lockwasher |
| 3 | A30005 | Cast socket half (rear, w/ zerk hole) |
| 4 | A2206 | Zerk. 1/8" NPT w/ long straight shank |
| 5 | A30004 | Cast socket half (front) |
| 6 | A2203A | Ball swivel, 1-1/4" NF thread |
| 7 | A902A | Pole and axle |
| 8 | | Lockwasher, 1-1/4" |
| 9 | | Nut, 1-1/4" NF |

REAR FRAME & MOLDBOARD

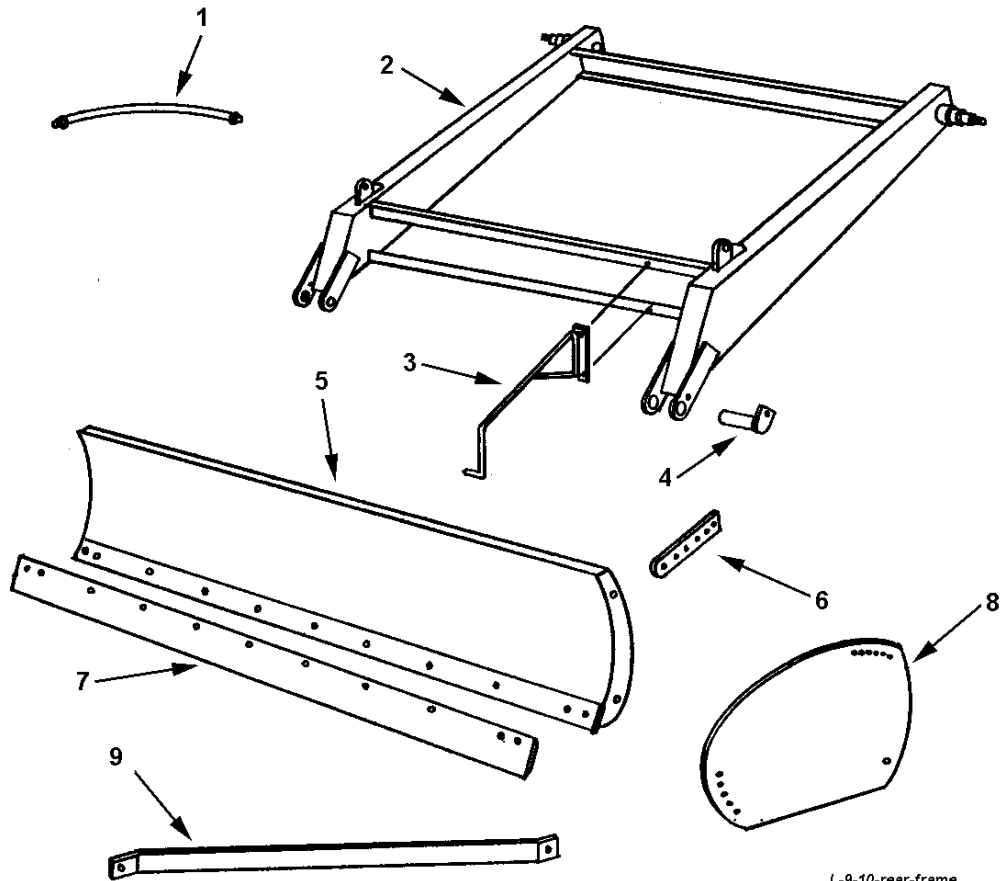

| KEY NO. | PART NO. | DESCRIPTION |
|---------|----------|---|
| 1 | A45H06 | Hydraulic hose, 1/2" x 24" (4 req'd) |
| 2 | A906 | Rear frame section |
| 3 | A908 | Depth gauge pointer |
| 4 | A911 | Pin, 1-1/2" x 6" with grease hole (uses 1/2 x 1" NC capscrew w/ lockwasher) |
| 5 | A904 | Moldboard assembly, 9 ft. |
| | A913 | Moldboard assembly, 10 ft. |
| 6 | A907 | Tilt Bracket |
| 7 | A905 | Cutting edge, 9 ft. |
| | A10S02 | Cutting edge, 10 ft. |
| 8 | A910 | Moldboard end plate (right and left same) (uses 3/4" x 1-1/2" bolt at bottom rear and 1/2" by 1-1/2" bolt at top) |
| 9 | A909 | End plate brace for 9 ft. moldboard (uses 5/8" x 2" bolt at frame and 5/8" x 1-1/2" at end plate) |
| | A914 | End plate brace for 10 ft. moldboard |

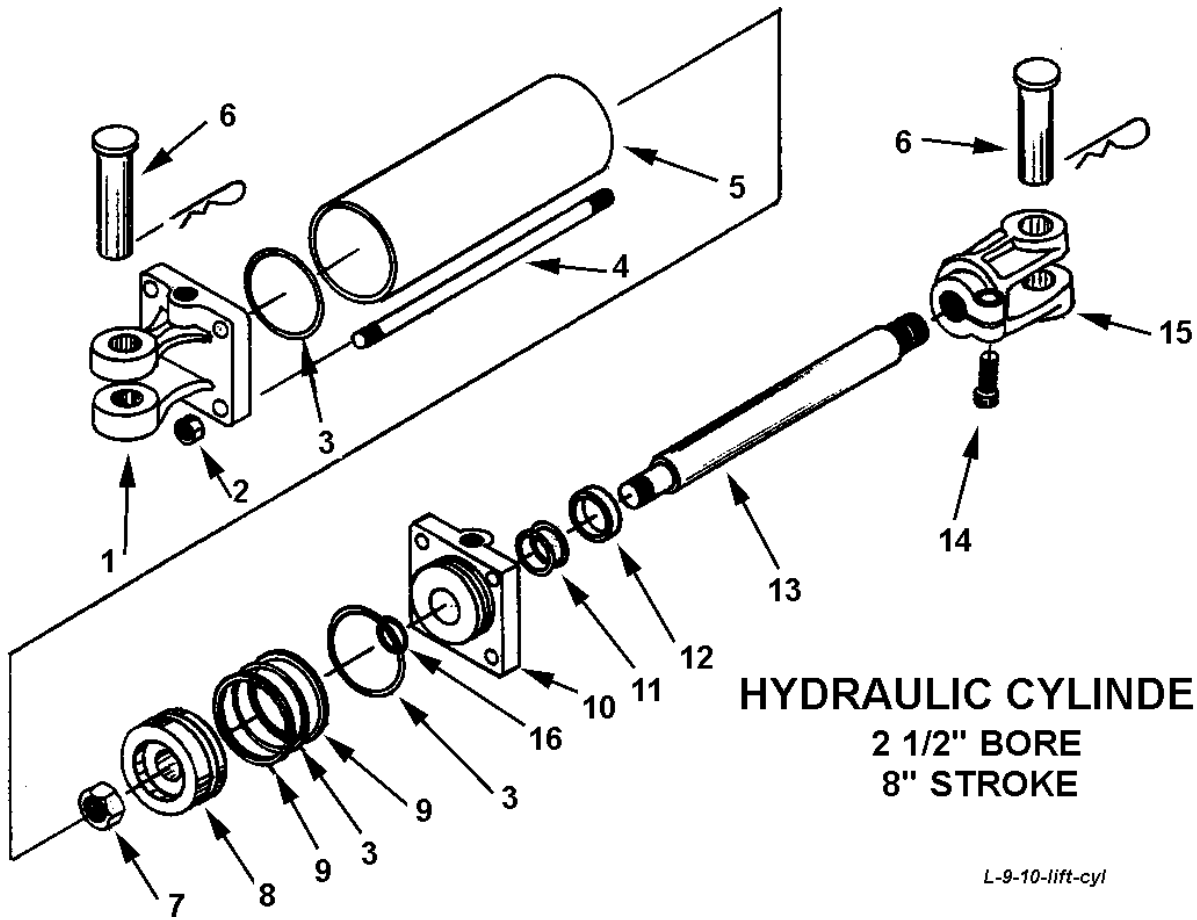

HYDRAULIC CYLINDER
2 1/2" BORE
8" STROKE

L-9-10-lift-cyl

CYL. # A258-DA

| KEY NO. | PART NO. | DESCRIPTION |
|---------|----------|---------------------------------|
| 1 | A9H15 | Base end clevis |
| 2 | | Nut, 3/8" NC |
| 3 | A22H22 | O-ring, 2-1/2" OD x 3/16" |
| 4 | A9H16 | Tie rod |
| 5 | A9H17 | Barrel, 2-1/2" ID |
| 6 | A912 | Pin, 1" dia., w/ clip pin |
| 7 | A9H18 | Piston nut |
| 8 | A9H19 | Piston, 2-1/2" dia. |
| 9 | A22H21 | Back up washer, 2-1/2" OD |
| 10 | A9H20 | Head gland |
| 11 | A9H21A | Shaft seal, 1-1/16" |
| 12 | A9H22A | Wiper seal, 1-1/16" |
| 13 | A9H23A | Shaft, 1-1/16" |
| 14 | | Capscrew, 5/16" NC socket head |
| 15 | A9H24 | Clevis end |
| 16 | A9H25 | Piston gasket |
| | A9H26 | Packing kit containing: |
| | | 3 A22H22 1 A9H21 2 A22H21 |
| | | 1 A9H22 1 A9H25 |

WHEEL, HUB & SPINDLE

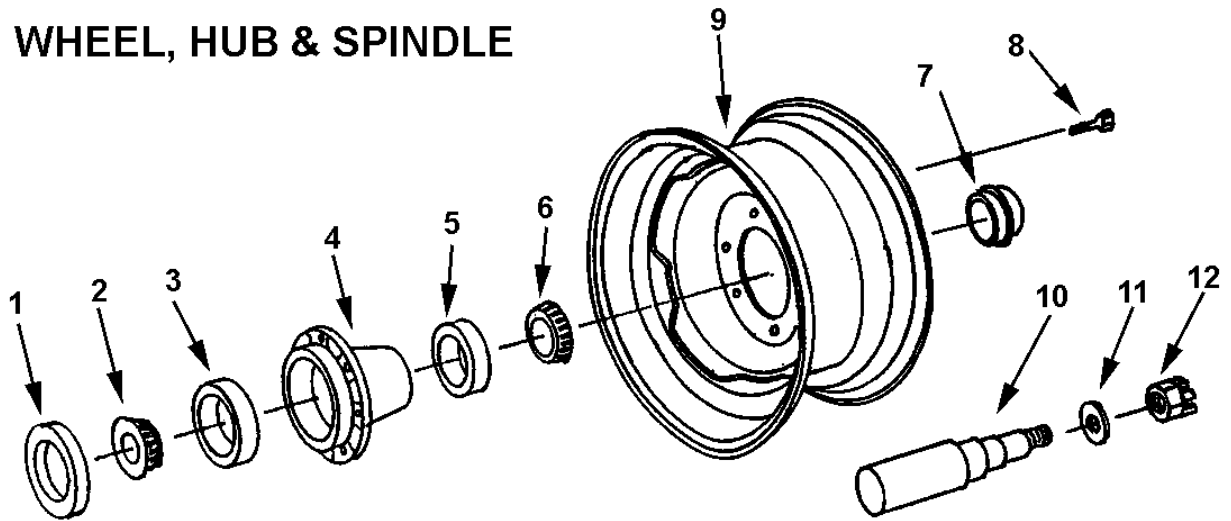

L-9-10-wheel

| KEY NO. | PART NO. | DESCRIPTION |
|---------|----------|---|
| 1 | A2229 | Grease seal |
| 2 | A2230 | Bearing cone (inner) |
| 3 | A2231 | Bearing cup (inner) |
| 4 | A2232 | Hub, less bearings |
| 5 | A2233 | Bearing cup (outer) |
| 6 | A2234 | Bearing cone (outer) |
| 7 | A2235 | Hub cap |
| 8 | A2236 | Wheel bolt |
| 9 | A3319 | Wheel, 15" x 6" |
| 10 | A2238 | Spindle |
| 11 | A2239 | Washer, special 7/8" flat |
| 12 | | Nut, 7/8" NF castellated Cotterpin, 3/16" x 1-1/2" |