

Ashland **INDUSTRIES, INC.™**

*Quality
Equipment
Since
1953*

I-80 PARTS MANUAL

Version 4-04

Ashland Industries Inc.
1115 Rail Drive
P.O. Box 717
Ashland, WI. 54806
Ph: 877-634-4622 *Toll Free*
Ph: 715-682-4622
Fx: 715-682-9717
www.ashlandind.com

MEMBER
CIMA
CONSTRUCTION INDUSTRY
MANUFACTURERS ASSOCIATION



HOW TO ORDER PARTS:

IMPORTANT

Parts must be ordered through your local authorized ASHLAND dealer.

Be sure to state MODEL and SERIAL NUMBER of your machine, PART NUMBER, DESCRIPTION and QUANTITY needed.

Unless this is done, we cannot provide prompt service or assure shipment of the correct parts.



Ashland Industries weldable replacement parts are available to rebuild, modify or update your scraper to current factory specifications.

INDEX

PAGE NO.	
3.	Operator and Maintenance Instructions
4.	Safety Guidelines
5.	Illustration - Assembly
6.	Gooseneck Frame Assembly
7.	Apron Assembly
8.	Bowl and Frame Assembly
9.	Push Off Gate Assembly
10.	Pole and Axle Assembly
11.	Wheel, Hub and Spindle Assembly
12.	Hyd. Cylinder, 3 ½ " x 16"
13.	Hyd. Cylinder, 3 ½" x 10", Right
14.	Hyd. Cylinder, 3 ½", x 10", Left
15.	Hyd, Cylinder, 4" x 42"
16-17.	Hydraulic Circuit
18.	Counterbalance Valve
19.	Instructions for Adjusting Hydraulic Valve
20.	Warranty Statement

OPERATORS AND MAINTENANCE INSTRUCTIONS

This scraper is a durable piece of equipment and with proper care will yield many years of trouble free operation. The scraper requires a power source with TWO 4 way (double acting) hydraulic control valves.

The scraper should be greased at all points where grease fittings are provided. Connect hydraulic hoses to the tractor and retract lift cylinders to **REMOVE TRANSPORT LOCK PINS** (point A), then extend and retract all cylinders several times to force out any air from the hydraulic cylinders and lines. Check the oil levels in the tractor hydraulic system and add to maintain the proper level. Care should be used when adding oil or when disconnecting any oil line to keep all dirt out of the oil as dirt is a major factor in the failure of hydraulic components.

When the scraper is placed into operation, the operator will have to "feel out" the amount of depth of cut to obtain maximum loading efficiency. This is usually accomplished by taking a lesser and more uniform cut; however, some soil conditions such as loose sand may require a "pumping action" obtained by taking successive deep cuts and lifting out of cut as the tractor begins to lose power or traction.

1. After 10 hours work, all bolts should be checked and tightened if necessary.
2. Every 10 hours all grease fittings should be lubricated.
3. After 50 hours work, all bolts should be rechecked and tightened if necessary. Check wheel bearings and adjust if necessary.
4. After 300 hours work, clean and repack wheel bearings and replace, if necessary, cutting edges, worn pins, etc.



SAFETY SIGNAL WORDS

Note the use of the signal words *DANGER*, *WARNING* and *CAUTION* with the safety messages. The appropriate signal word for each has been selected using the following guidelines:

DANGER: Indicates an imminently hazardous situation that, if not avoided, will result in death or serious injury. This signal word is to be limited to the most extreme situations typically for machine components which, for functional purposes, cannot be guarded.



WARNING: Indicates a potentially hazardous situation that, if not avoided, could result in death or serious injury, and includes hazards that are exposed when guards are removed. It may also be used to alert against unsafe practices.



CAUTION: Indicates a potentially hazardous situation that, if not avoided, may result in minor or moderate injury. It may also be used to alert against unsafe practices.



GENERAL SAFETY GUIDELINES

Safety of the operator is one of the main concerns in designing and developing a new piece of equipment. Designers and manufacturers build in as many safety features as possible. However, every year many accidents occur which could have been avoided by a few seconds of thought and a more careful approach to handling equipment. You, the operator, can avoid many accidents by observing the following precautions in this section. To avoid personal injury, study the following precautions and insist those working with you, or for you, follow them.

Replace any CAUTION, WARNING, DANGER or instruction safety decal that is not readable or is missing. Location of such decals is indicated in this booklet.

Do not attempt to operate this equipment under the influence of drugs or alcohol.

Review the safety instructions with all users annually.

This equipment is dangerous to children and persons unfamiliar with its operation. The operator should be a responsible adult familiar with farm machinery and trained in this equipment's operations. **Do not allow persons to operate or assemble this unit until they have read this manual and have developed a thorough understanding of the safety precautions and of how it works.**

To prevent injury or death, use a tractor equipped with a Roll Over Protective System (ROPS). Do not paint over, remove or deface any safety signs or warning decals on your equipment. Observe all safety signs and practice the instructions on them.

Never exceed the limits of a piece of machinery. If its ability to do a job, or to do so safely, is in question - **DON'T TRY IT.**

ILLUSTRATION - ASSEMBLY

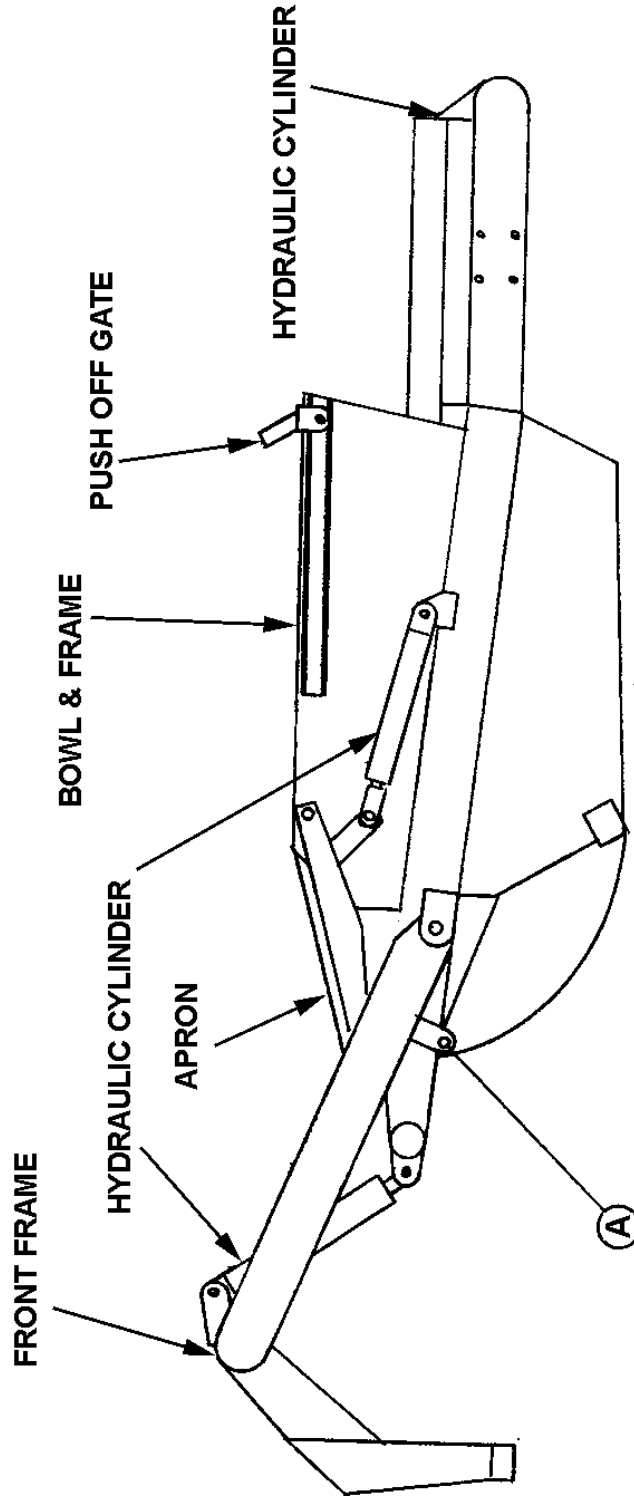

GOOSENECK FRAME ASSEMBLY

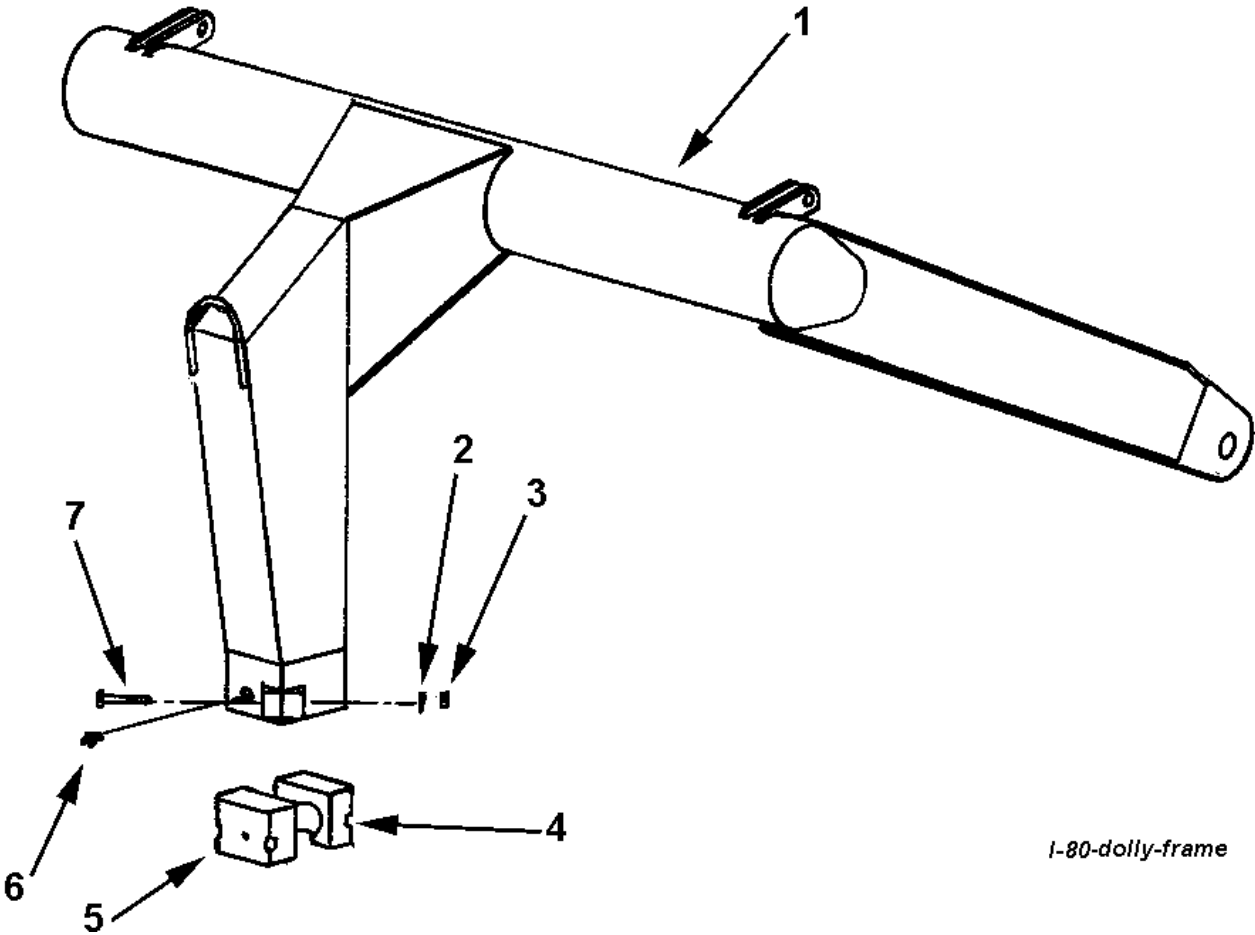

I-80-dolly-frame

KEY NO.	PART NO.	DESCRIPTION
1	A8057A	Gooseneck frame, s/n 15802 & up
	A8057	Gooseneck frame, up thru s/n 15801
2		Lock washer, 5/8"
3		Nut, 5/8" NC
4	A40004	Cast socket half, rear
5	A40005	Cast socket half, front w/ zerk hole
6	A2206	Grease zerk, long shank
7		Bolt, 5/8" NC x 4"

APRON ASSEMBLY

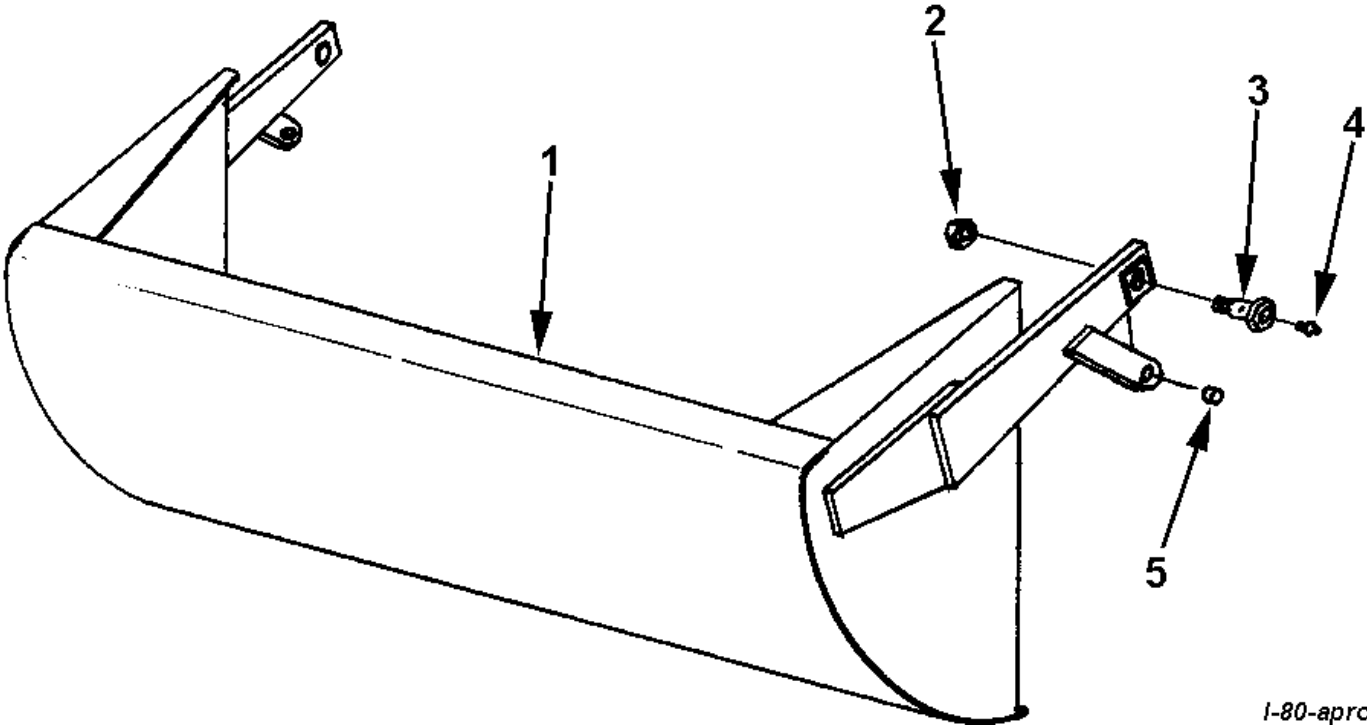

1-80-apron

<u>KEY NO.</u>	<u>PART NO.</u>	<u>DESCRIPTION</u>
1	A8060	Apron
2		Self locking nut, 1-1/4"
3	A6010	Shoulder pin, 1-5/8" to 1-1/4" with zerk in head
4		Grease fitting
5	A10155	Bushing, 1-1/2" OD x 1-1/8" ID x 1-1/8" long

BOWL AND FRAME ASSEMBLY

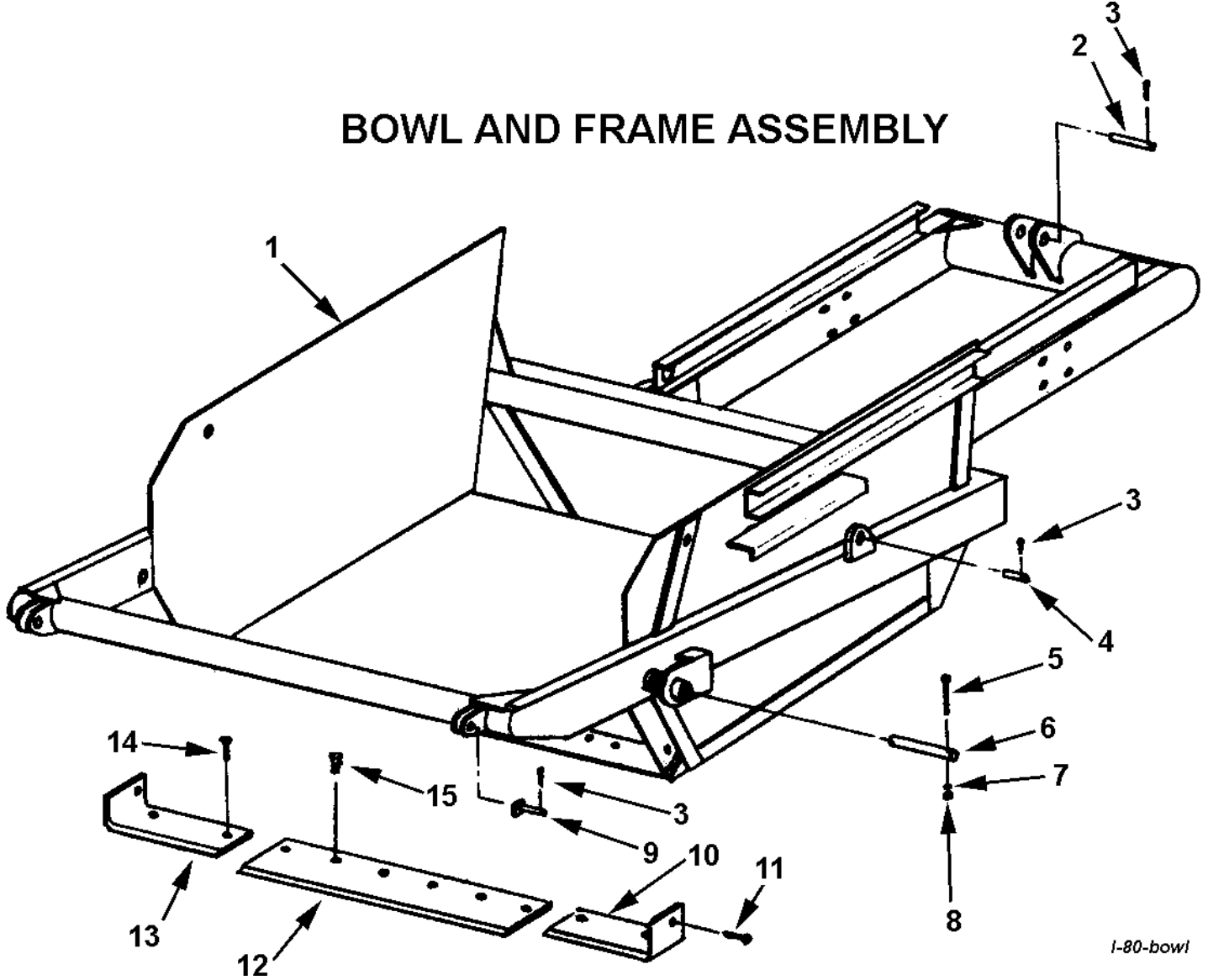

I-80-bowl

KEY NO.	PART NO.	DESCRIPTION
1	A8055	Bowl and frame, up to s/n 15332
	A8055A	Bowl and frame, s/n 15379 & up
2	A8062	Pin, 1-1/4" x 7"
3		Cotter pin
4	A1217	Pin, 1" x 3-1/2"
5		Bolt, 3/8" NC x 4"
6	A8056	Pin, 1-3/4" x 8"
7		Lockwasher, 3/8"
8		Nut, 3/8" NC
9	A8064	Pin, 1" x 3-7/8"
10	A2225	Right cutting edge, 1/2" x 6"
	A8029A	Right cutting edge, 3/4" x 6", s/n 17807 & up (standard)
11		Plow bolt, 1/2" x 1-1/4" w/ nut
12	A8030	Center cutting edge, 3/4" x 8" x 54"
13	A2222	Left cutting edge, 1/2" x 6"
	A8031A	Left cutting edge, 3/4" x 6", s/n 17807 & up (standard)
14		Plow bolt, 1/2" x 1-3/4" w/ nut (8 req'd)
15		Plow bolt, 5/8" x 2" w/ nut (6 req'd)

PUSH OFF GATE ASSEMBLY

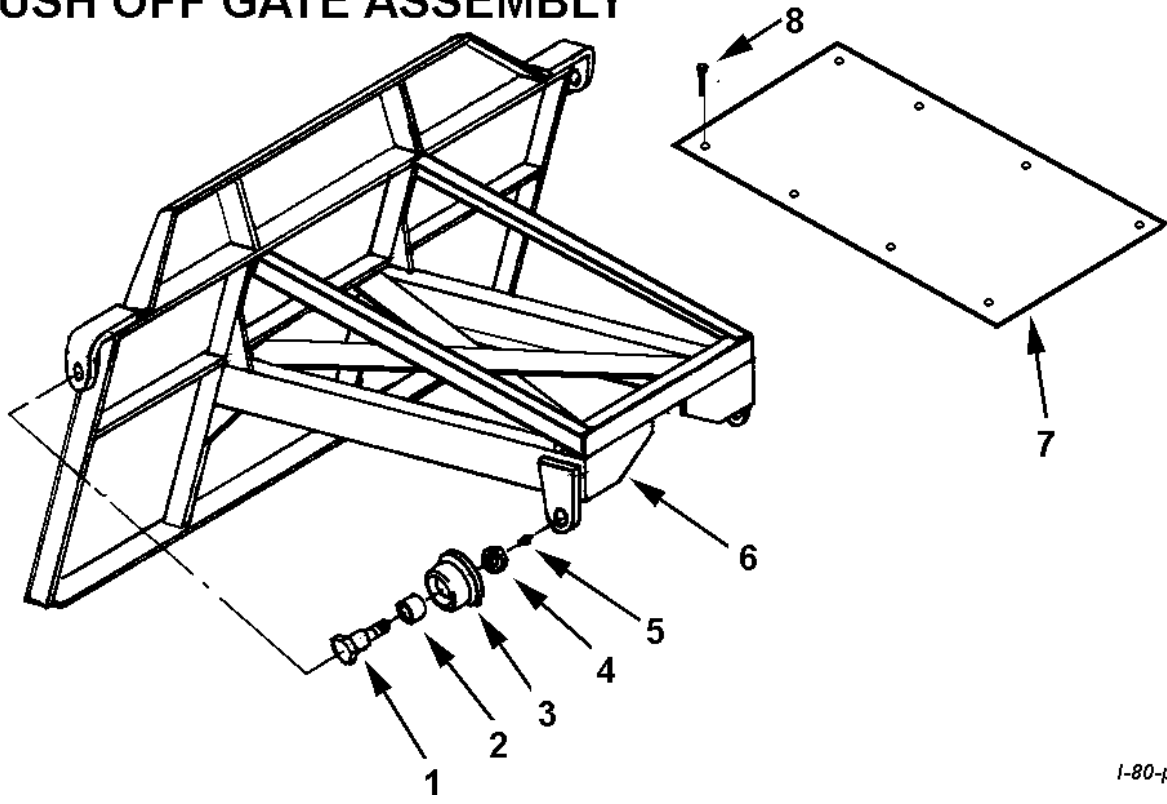

l-80-pushoff

KEY NO.	PART NO.	DESCRIPTION
1	A10008	Shoulder pin, 1-5/8" to 1-1/4" with zerk in threaded end
2	A10162	Bushing, 2" OD x 1-5/8" ID x 1-1/2"
3	A10161	Gate roller, with bushing
4		Jam nut, 1-1/4" NF
5		Grease fitting, 1/8" NPT straight
6	A9056	Push off gate
7		Dirt shield
8		Bolt, 3/8" NC x 1"

POLE AND AXLE ASSEMBLY

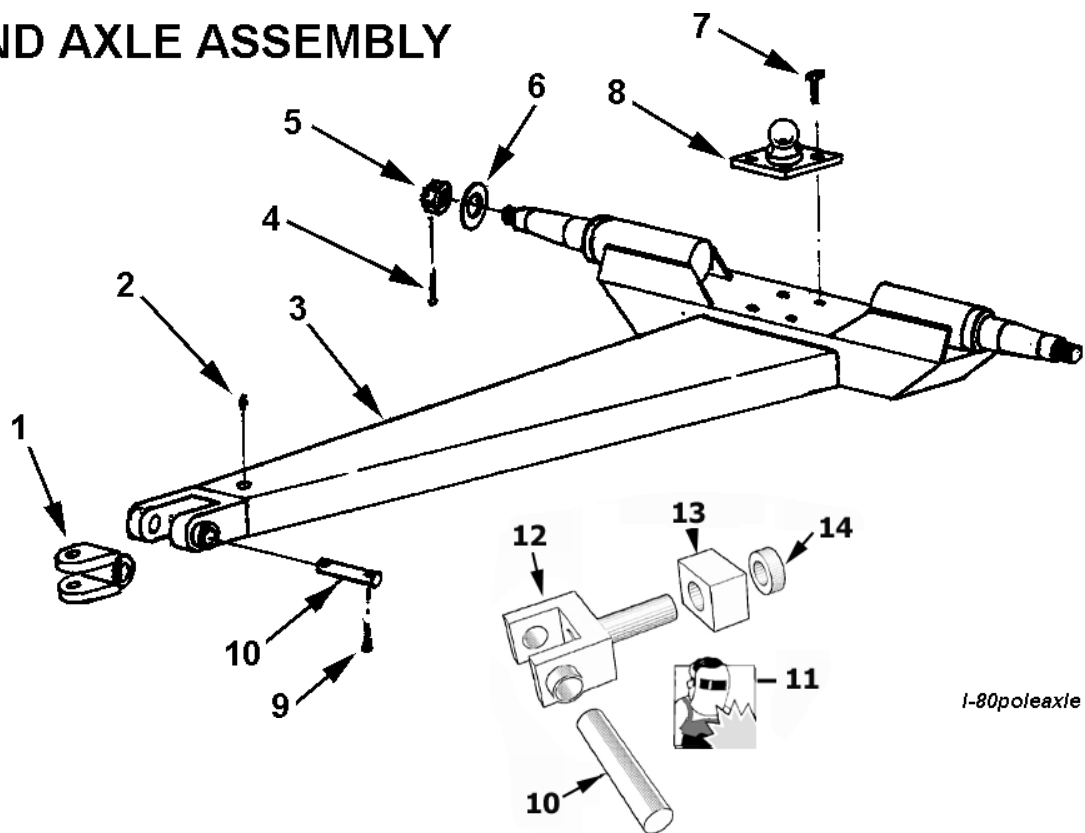

I-80poleaxle

KEY NO.	PART NO.	DESCRIPTION
1	A6013	Clevis hitch
2		Grease fitting, 1/8" NPT
3	A8063	Pole, s/n 15802 & up
	A8014	Pole, up thru s/n 15801
4		Cotter pin, 3/16" x 2"
5		Nut castellated, 1-1/4" NF
6	A8027	Washer, special 1-1/4" flat
7		Bolt, 3/4" NC x 2-1/2" long
8	A40006	Ball swivel
9		Bolt, 5/16" x 2-1/2"
10	A6014	Pin, 1-1/4" x 6-3/4" w/ bolt holes
11	A10033W	Swivel Hitch Rebuild Kit, includes items 10, 12, 13, 14
12	A030168-3	Hitch: Swivel Yoke
13	A030568-1	Hitch: Swivel Block
14	A030568-2	Hitch: Retaining Collar

WHEEL, HUB AND SPINDLE

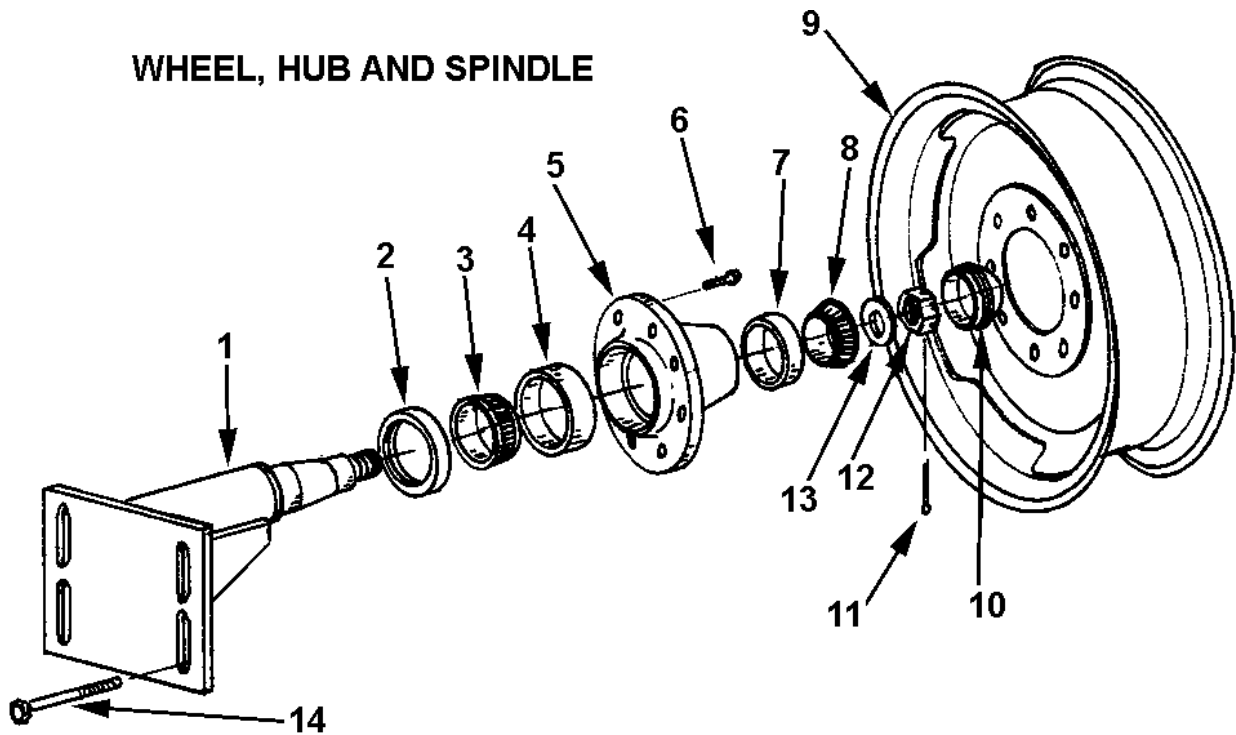

1-80wheel

KEY NO.	PART NO.	DESCRIPTION
1	A8028	Spindle weldment
2	A8020	Grease seal (CR 35062)
3	A8021	Bearing cone, inner (Timken 39581)
4	A8022	Bearing cup, inner (Timken 39520)
5	A8023	Hub
6	A4519	Wheel bolt, 9/16" NF
7	A8024	Bearing cup, outer (Timken 3525)
8	A8025	Bearing cone, outer (Timken 3585)
9	A6022	Wheel, 16.1" x 11" DC, rear
	A8065	Wheel, 16" x 10" DC, front
10	A8026	Hub cap
11		Cotter pin
12		Spindle nut
13	A8027	Spindle washer, special
14		Bolt, 1" NC x 6-1/2" long

HYDRAULIC CYLINDER DIG AND LIFT CIRCUIT

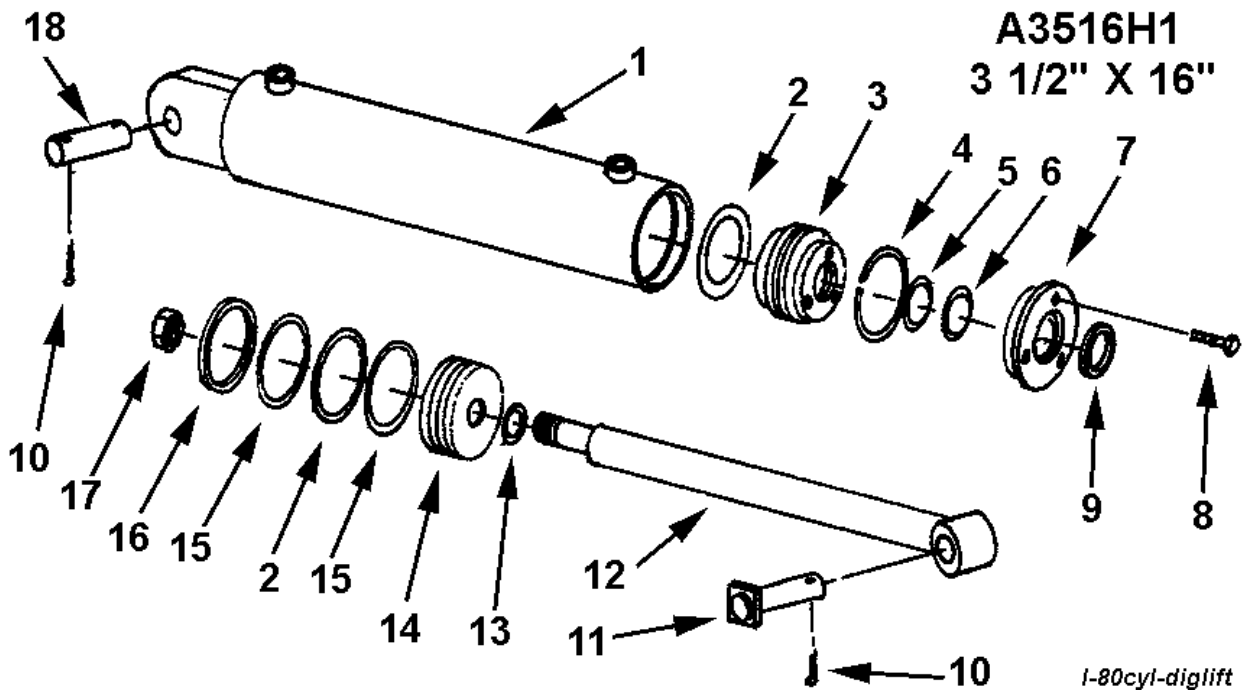

KEY NO.	PART NO.	DESCRIPTION
1	A22H12	Barrel Assembly
2	A22H08	O-ring, 3-1/2" OD x 3/16"
3	A22H13	Head gland
4	A22H14	Retainer ring
5	A22H15	O-ring, 1-1/2" ID x 1/8"
6	A22H15A	Backup washer
7	A22H16	Head cap
8	A22H18	Capscrew, 1/4" x 1"
9	A22H17	Wiper seal
10		Cotter pin, 3/16" x 1-1/2"
11	A8064	Pin, 1" x 3-7/8"
12	A22H11	Shaft, 1-1/2" diameter
13	A22H10A	Piston gasket, 3/4" ID
14	A22H09	Piston, 3-1/2"
15	A22H07	Backup washer, 3-1/2" OD
16	A22H06	Cast iron ring, 3-1/2" OD
17	A22H05	Piston nut, 3/4" NF
18	A2205	Pin, 1" x 3-1/4"
	A22H19B	Packing kit containing:
		1 - A22H06 2 - A22H15 2 - A22H07
		1 - A22H15A 2 - A22H08 1 - A22H17
		1 - A22H10A

HYDRAULIC CYLINDER

A3510H1
3-1/2" X 10"

APRON CIRCUIT,
RIGHT SIDE

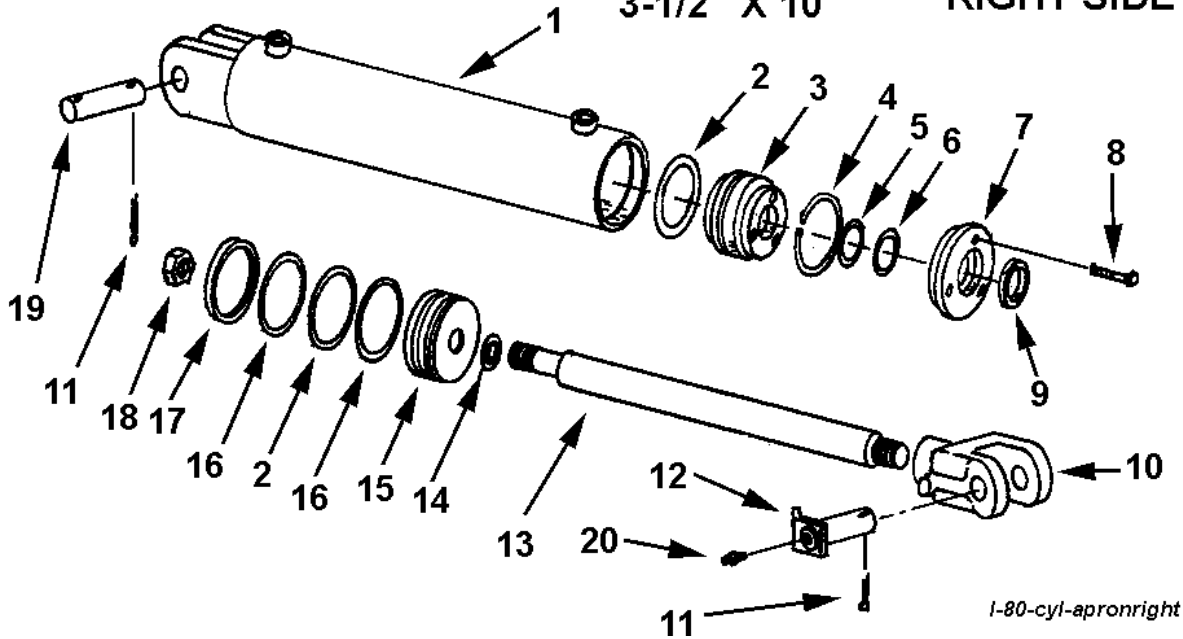

<u>KEY NO.</u>	<u>PART NO.</u>	<u>DESCRIPTION</u>
1	A12H04	Barrel
2	A22H08	O-ring, 3-1/2" OD
3	A22H13	Head gland
4	A22H14	Retainer ring
5	A22H15	O-ring, 1-1/2" ID x 1/8" thickness
6	A22H15A	Backup washer
7	A22H16	Head cap
8	A22H18	Socket head capscrew, 1/4 x 1"
9	A22H17	Wiper seal, 1-1/2" ID
10	A12H03	Clevis end
11		Cotter pin, 3/16" x 1-1/2"
12	A10167	Pin, 1" x 3-1/16"
13	A12H02	Shaft, 1-1/2" diameter
14	A22H10	Piston gasket, 3/4" ID
15	A22H09	Piston
16	A22H07	Back up washer, 3-1/2" OD
17	A22H06	Piston ring, 3-1/2" x 3/16", cast iron
18	A22H05	Piston nut, 3/4" NF
19	A1217	Pin, 1" x 3-1/2"
20	A2205	Grease fitting
	A22H19B	Packing kit containing:
		1 - A22H06 2 - A22H07 2 - A22H08
		1 - A22H10 1 - A22H14 1 - A22H15
		1 - A22H15A 1 - A22H17

HYDRAULIC CYLINDER

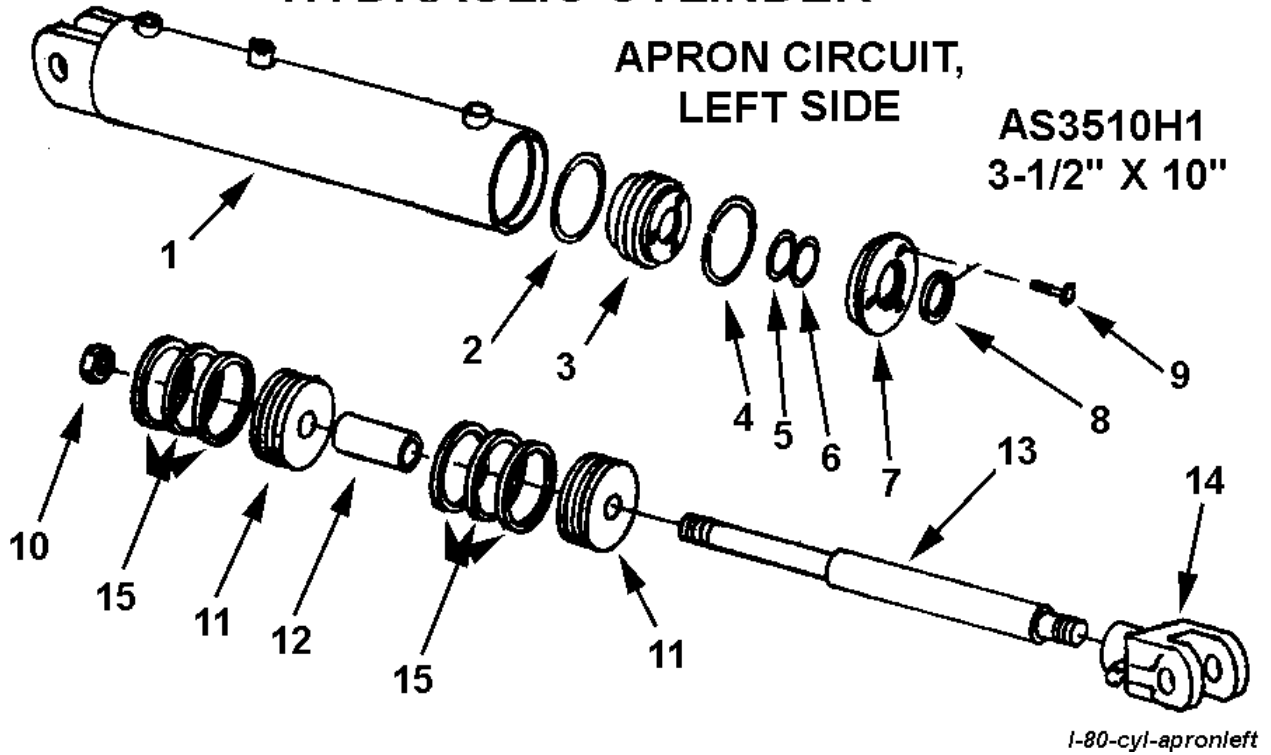

KEY NO.	PART NO.	DESCRIPTION
1	A101H78A	Barrel
2	A22H08	O-ring, 3-1/2" OD x 3/16"
3	A22H13	Head gland
4	A22H14	Retainer ring
5	A22H15	O-ring, 1-1/2" ID
6	A22H15A	Backup washer, 1-1/2" ID
7	A22H16A	Gland cap
8	A22H17	Wiper seal, 1-1/2" ID
9	A22H18A	Capscrew, 1/4" NC x 1"
10	A300H03	Piston nut
11	A101H79A	Piston, 3-1/2"
12	A130H12A	Piston spacer
13	A101H80A	Shaft, 1-1/2" diameter
14	A12H03	Clevis end
15	A22H06A	Cast iron rings, 3-1/2" x 1/4"
	A101H81A	6 - A22H06A 1 - A22H08 1 - A22H15 1 - A22H15A 1 - A22H17

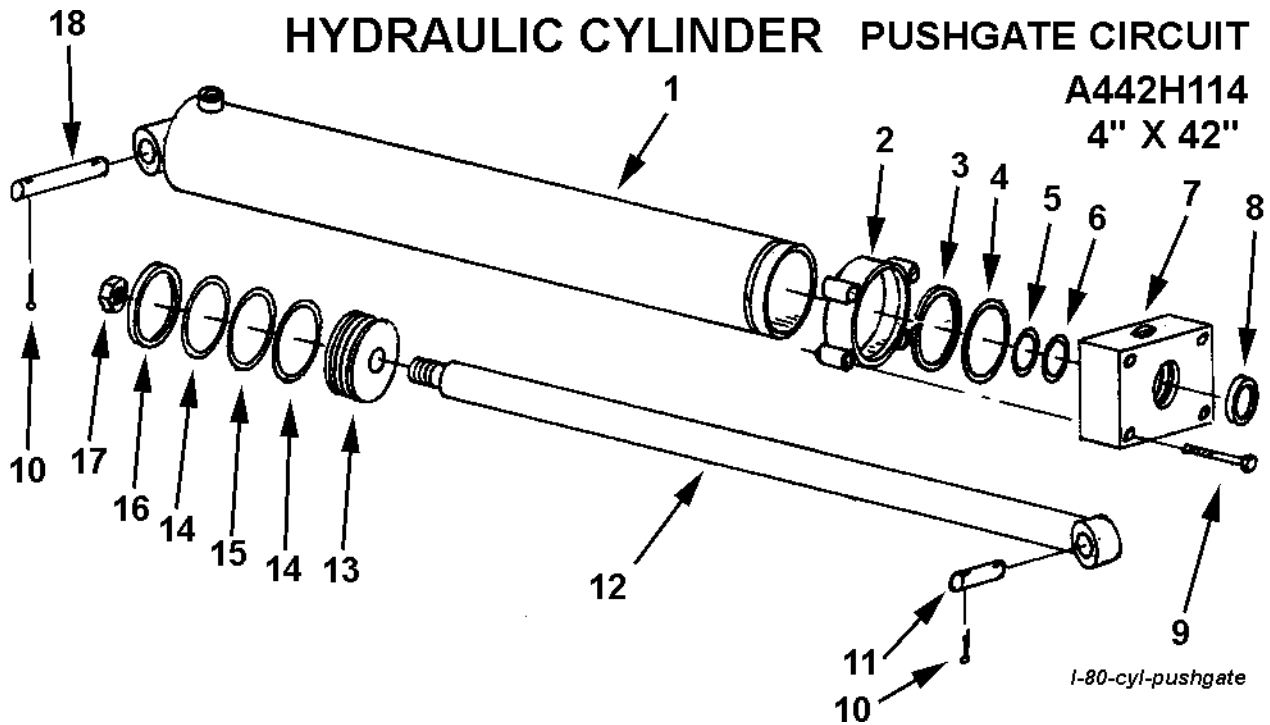

KEY NO.	PART NO.	DESCRIPTION
1	A80H21	Barrel Assembly
2	A80H22	Clamp ring
3	A80H23	Retainer ring
4	A80H24	O-ring, 4" OD x 1/8"
5	A400H12	O-ring, 2" ID
6	A400H12A	Backup washer
7	A80H25	Head gland
8	A80H06	Wiper seal, 2" ID
9		Bolt, 1/2" NF x 4-1/2", Gd 5, w/ nut
10		Cotter pin, 1/4" x 4"
11	A8061	Pin, 1-1/4" x 4"
12	A80H26	Rod Assembly
13	A80H27	Piston
14	A300H05	Backup washer, 4" OD
15	A300H06	O-ring, 4" OD x 3/16"
16	A300H04	Cast iron ring, 4" OD
17	A400H17	Piston nut, 1-1/4" NF
18	A8062	Pin, 1-1/4" x 6-1/2"
	A80H30	Packing kit containing:
		1 - A80H24 2 - A300H05 1 - A400H12
		1 - A300H06 1 - A400H12A 1 - A300H04
		1 - A80H06

HYDRAULIC CIRCUIT

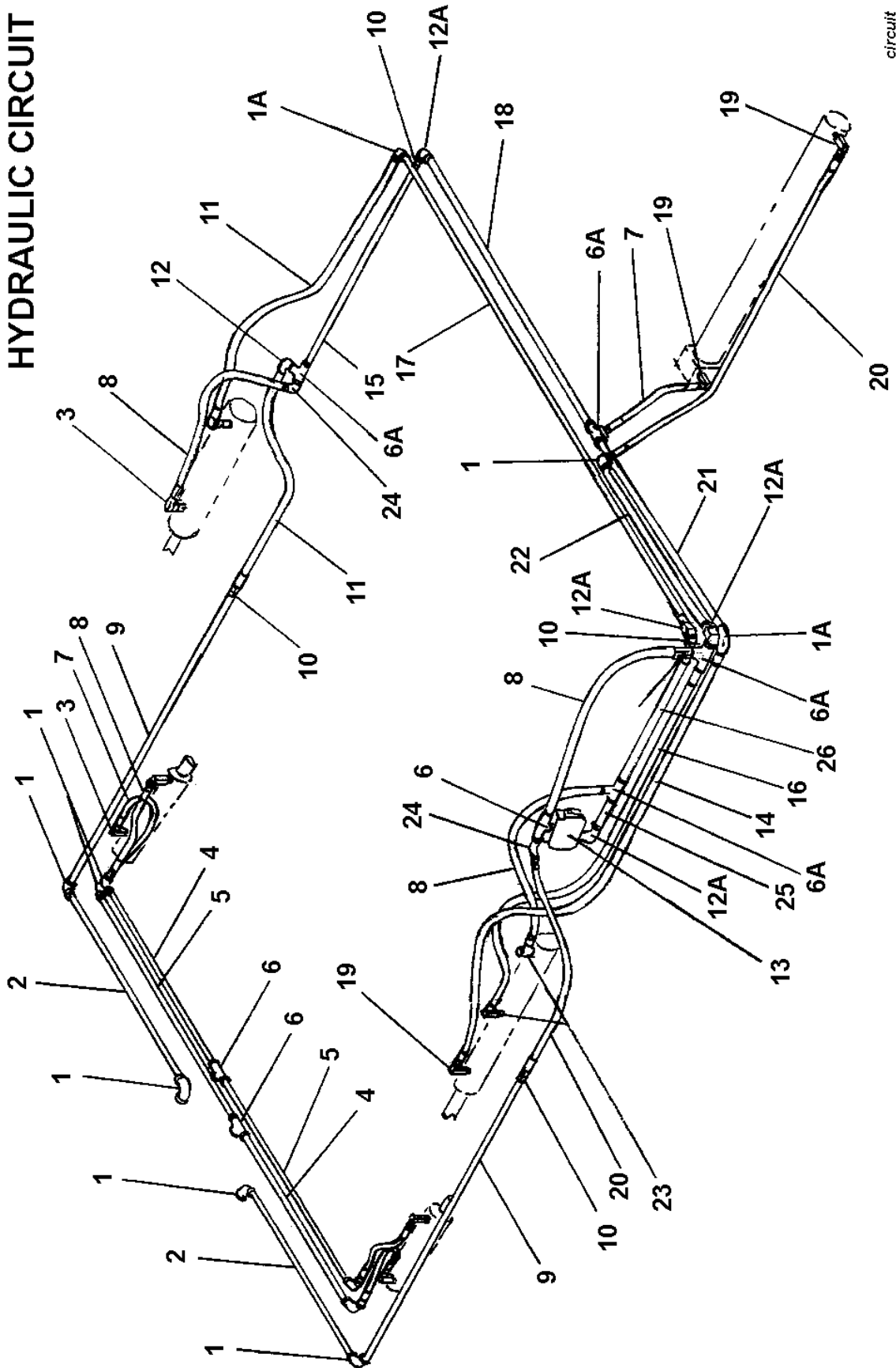

circuit

PARTS LIST HYDRAULIC CIRCUIT

s/n 16510 & up

<u>KEY #</u>	<u># REQ'D</u>	<u>PART #</u>	<u>DESCRIPTION</u>
1	9		Elbow, 90°, 1/2" NPT, Cast
1A	2		Elbow, 90°, 1/2" NPT, Steel
2	2		Pipe, 1/2" x 41" long
3	6	A45H07	Swivel adapter, 90°, 3/8" male x 1/2" female
4	2		Pipe, 1/2" x 32-3/4" long
5	2		Pipe, 1/2" x 34-3/4" long
6	3		Pipe tee, 1/2" NPT, Cast
6A	4		Pipe tee, 1/2" NPT, Steel
7	3	A60H01A	Hose, 1/2" x 18" long
8	5	A45H06	Hose, 1/2" x 24" long
9	2		Hose, 1/2" x 64" long
10	4	A101H74	Swivel adapter, straight, 1/2" female x female
11	2	A80H11	Hose, 1/2" x 40" long
12	1		Street elbow, 90°, 1/2" NPT, Cast
12A	4	A101H73	Street elbow, 90°, 1/2" NPT, Steel
13	1	A101H48	Counterbalance valve
14	1	A80H46	Hose, 1/2" x 51" long
15	1		Pipe, 1/2" x 25" long
16	1	A400H01	Hose, 1/2" x 38" long
17	1		Pipe, 1/2" x 85-3/4" long
18	1		Pipe, 1/2" x 47-1/4" long
19	5	A400H02	Swivel adapter, 90°, 1/2" male x female
20	2	A80H29	Hose, 1/2" x 46" long
21	1		Pipe, 1/2" x 39-3/4" long
22	1		Pipe, 1/2" x 37-1/4" long
23	2		Pipe bushing, 3/4" NPT x 1/2" NPT
24	2		Street elbow, 45°, 1/2" NPT, Cast
25	1		Pipe, 1/2" x 3" long
26	1		Pipe, 1/2" x 13" long
27	1	A600H28	Check valve

COUNTERBALANCE VALVE

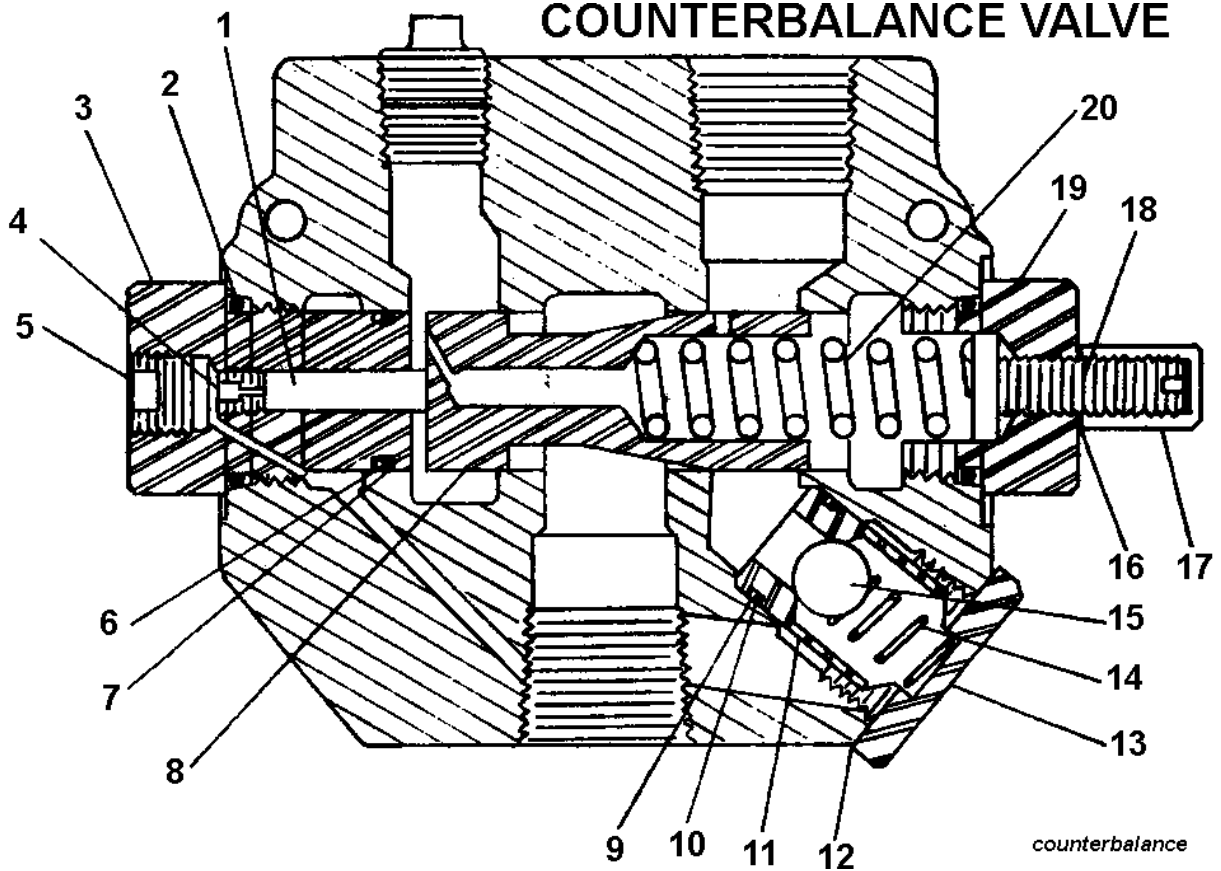

KEY NO.	PART NO.	DESCRIPTION
1	A101H49	Piston
2	A101H50	O-ring
3	A101H51	External pilot plug
4	A101H52	Orifice
5	A101H53	Plug
6	A101H54	O-ring
7	A101H55	Backup washer
*8	A101H56	Metering spool
9	A101H57	Backup washer
10	A101H58	O-ring
11	A101H59	Check seat
12	A101H60	Aluminum washer
13	A101H61	Check plug
14	A101H62	Check spring
15	A101H63	Check ball
16	A101H64	Aluminum washer
17	A101H65	Acorn nut
18	A101H66	Adjusting screw
19	A101H67	Adjusting plug - RD1075 CB
20	A101H68	Metering spring
*	A101H71	Valve body
* NOT SOLD SEPARATELY		

COUNTERBALANCE VALVE

PURPOSE of the counterbalance valve is to prevent the front gate from closing before the rear pushgate is fully retracted when the scraper is empty. This enables the operator to start the next cut without having to reopen the gate from the closed position.

INSTRUCTIONS for establishing counterbalance valve setting:

When properly adjusted, the front gate will close 40% from full open position and hold at that position until the rear pushgate is fully retracted. If the front gate is closing more than 40%, remove the acorn cap nut and turn the adjusting screw clockwise until the front gate holds at that position. Turn an additional $\frac{1}{4}$ turn clockwise, then tighten the lock nut. DO NOT turn the adjusting screw more than is necessary to hold the front gate at 40% open.

Limited Warranty Statement

Ashland Industries Inc. warrants each new product to be free from defects in material and workmanship. This warranty is applicable only for the normal service life expectancy of the product or components, not to exceed **six consecutive months** from the date of delivery of the new Ashland Industries product to the original purchaser, or the date the product is first put into service via a rental agreement or other means, whichever occurs first.

Genuine Ashland Industries Inc. replacement parts and components will be warranted for 30 days from date of purchase, or the remainder of the original equipment warranty period, whichever is longer.

Under no circumstances will it cover any merchandise or components thereof, which in the opinion of the company, has been subjected to misuse, unauthorized modification, alterations, an accident or if repairs have been made with parts other than those obtained through Ashland Industries Inc.

Ashland Industries Inc. in no way warrants Tires since these items are warranted separately by their respective manufacturer. Please call Ashland Industries Inc. to receive phone numbers of tire suppliers.

Ashland Industries Inc. in no way warrants wearable items such as cutting edges, front dolly wheel balls, socket halves.

Our obligation under this warranty shall be limited to repairing or replacing, free of charge to the original purchaser, any part that, in our judgement, shall show evidence of such defect, provided further that such part shall be returned within 30 days from the date of failure to Ashland Industries Inc. routed through the dealer and distributor from whom the purchase was made, transportation charges prepaid. Upon warranty approval proper credits will be reimbursed for transportation.

This warranty shall not be interpreted to render Ashland Industries Inc. liable for injury or damages of any kind or nature to person or property. This warranty does not extend to the loss revenue, extra labor cost associated with downtime, substitute machinery, rental or for any other reason.

Except as set forth above, Ashland Industries Inc. shall have no obligation or liability of any kind on account of any of its equipment and shall not be liable for special or consequential damages. Ashland Industries Inc. make no other warranty, expressed or implied, and, specifically, Ashland Industries Inc. disclaims any implied warrant or merchantability or fitness for a particular purpose. Some states or provinces do not permit limitations or exclusions of implied warranties or incidental or consequential damages, so the limitations or exclusion in this warranty may not apply.

This warranty is subject to any existing conditions of supply which may directly affect our ability to obtain materials or manufacture replacement parts.

Ashland Industries Inc. reserves the right to make improvements in design or changes in specifications at any time, without incurring any obligation to owners of units previously sold

No one is authorized to alter, modify or enlarge this warranty nor the exclusion, limitations and reservations.

Ashland Industries Inc.
Warranty Department