



I-110 XL PARTS MANUAL



Ashland Industries Inc.
Hwy. 13 South
P.O. Box 717
Ashland, WI. 54806
877-634-4622 Toll Free - phone
715-682-4622 phone
715-682-9717 fax
www.ashlandind.com



MODEL I-110 XL SCRAPER

HOW TO ORDER PARTS:

Be sure to state MODEL and SERIAL NO. of machine, PARTS NO., DESCRIPTION, and QUANTITY wanted.

Unless this is done, we cannot provide prompt service or assure shipment of the correct parts.

INDEX

PAGE NO.

3. Illustration - Assembly
4. Operator and Maintenance Instructions
5. Gooseneck Frame Assembly
6. Apron Assembly
7. Bowl and Frame Assembly
8. Push Off Gate
9. Pole and Axle Assembly
10. Front Wheel and Hub Assembly
11. Rear Wheel, Spindle and Hub Assembly
12. Hydraulic Cylinder, 4" x 13", Apron
13. Hydraulic Cylinder, 4" x 16"
14. Hydraulic Cylinder, 4" x 54"
15. Hydraulic Valve
16. Hydraulic Valve Adjustment Instructions

ILLUSTRATION - ASSEMBLY

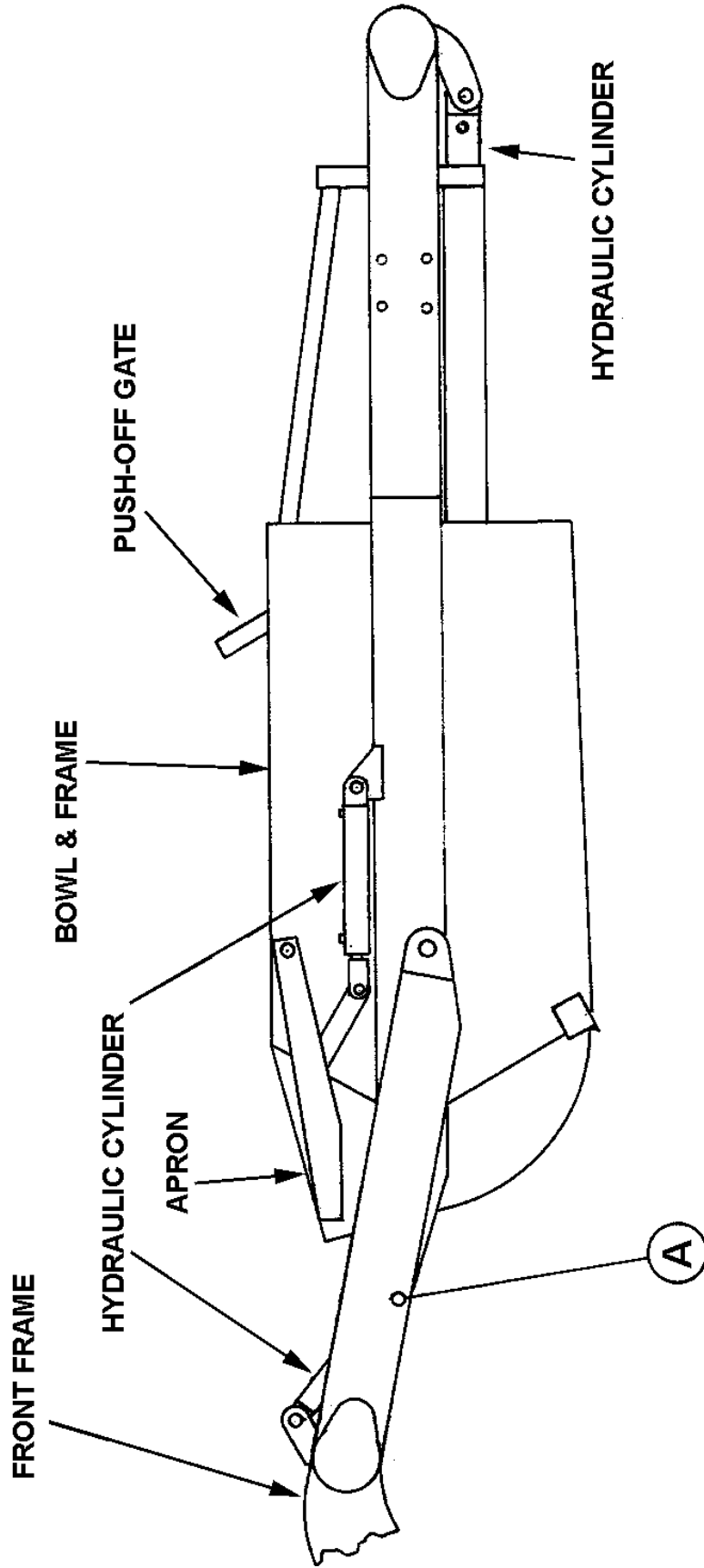

OPERATOR AND MAINTENANCE INSTRUCTIONS

The scraper is a durable piece of equipment and with proper care will yield many years of trouble free operation. The scraper requires a power source with TWO 4-way (double acting) hydraulic control valves.

The scraper should be greased at all points where grease fittings are provided. Connect hydraulic hoses to the tractor and retract lift cylinders to remove transport lock pins (point A), then extend and retract all cylinders several times to force out any air from the hydraulic cylinders and lines. Check the oil level in the tractor hydraulic system and add to maintain the proper level. Care should be taken when adding oil or when disconnecting any oil line to keep all dirt out of the oil as dirt is a major factor in the failure of hydraulic components.

When the scraper is placed into operation, the operator will have to "feel out" the amount of depth of cut to obtain maximum loading efficiency. This is usually accomplished by taking a lesser and more uniform cut. However, some soil conditions such as loose sand may require a "pumping action" obtained by taking successive deep cuts and lifting out of cut as the tractor begins to lose power or traction.

1. After 10 hours work, all bolts should be checked and tightened if necessary.
2. Every 10 hours all grease fittings should be lubricated.
3. After 50 hours work, all bolts should be rechecked and tightened if necessary. Check wheel bearings and adjust if necessary.
4. After 300 hours work, clean and repack wheel bearings and replace, if necessary, cutting edges, worn pins, etc.

ASHLAND INDUSTRIES, INC.

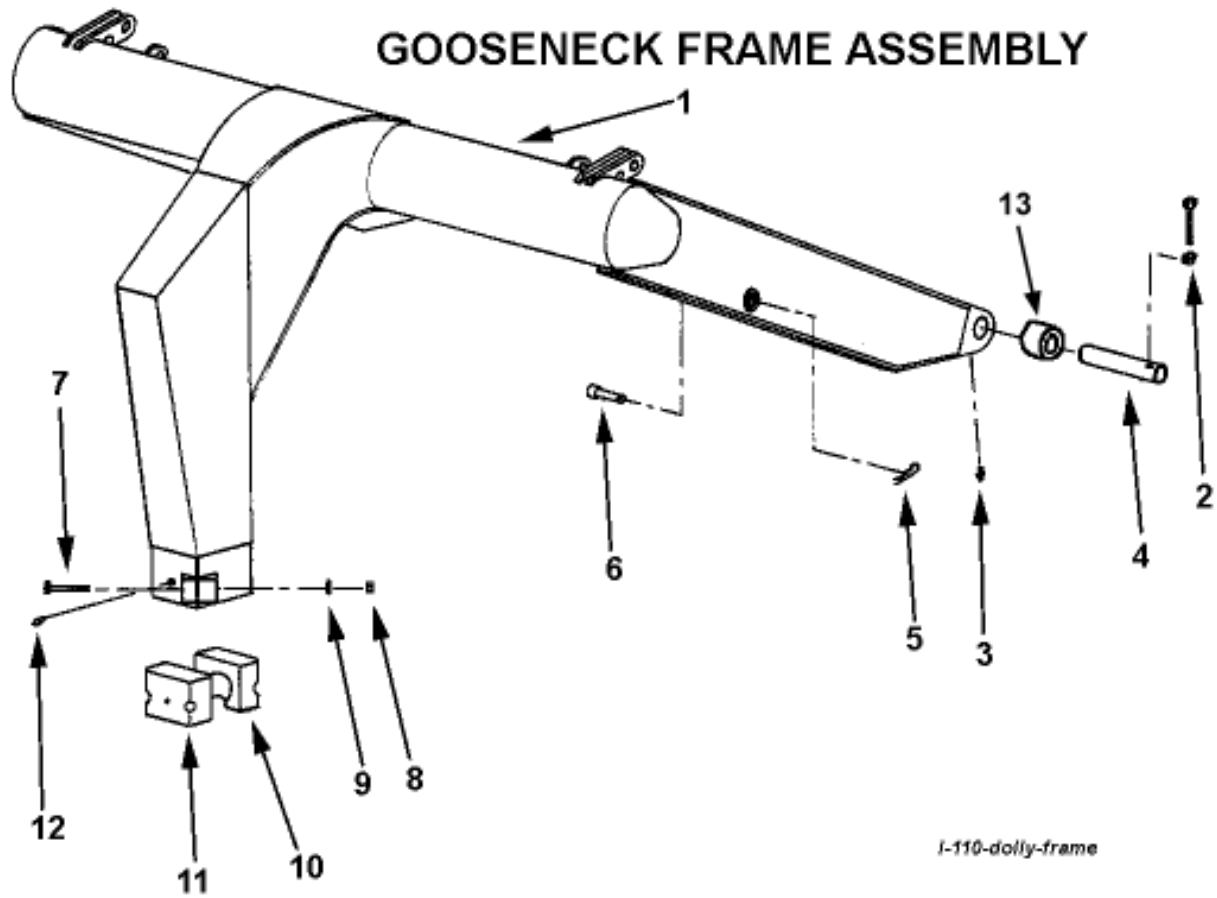

KEY NO.	PART NO.	DESCRIPTION
1	A10151A	Gooseneck frame, s/n 17816 & up
2	AFB-00054	Bolt, 1/2" NC x 3-1/2" w/ 7500 Nut
3	14505	Grease zerk, straight
4	A10152A	Pin, Frame attachment, 2" OD x 8-1/16" Long
5		Hair pin
6	A10153	Pin, Transport lock
7		Bolt, 3/4" x 4-1/2" gr. 8
8	7530	Nut, 5/8" NC
9	8110	Lockwasher, 5/8"
10	A10004A	Cast socket half, rear
11	A10005A	Cast socket half, front w/ zerk hole
12	A2006	Grease zerk, long shank
13	A14039	Bushing, 2.375 OD x 2.00 ID x 2" Long, Grease Passage

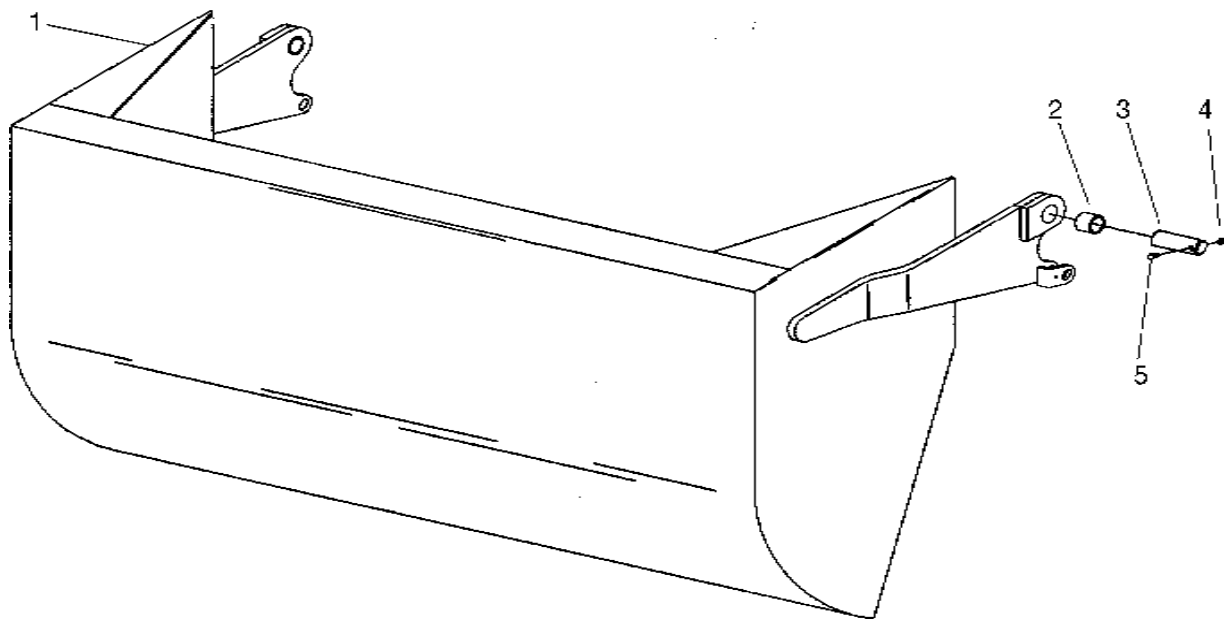

KEY NO.	PART NO.	DESCRIPTION
1	A123340	Apron
2	A123343	Bushing, 2" OD x 1-1/2" ID x 1-3/4" long,
3	A123336	Pin
4	7450	Nut: 3/8" NC
5	AFB-00049	Bolt: 3/8 NC X 3"

BOWL AND FRAME ASSEMBLY

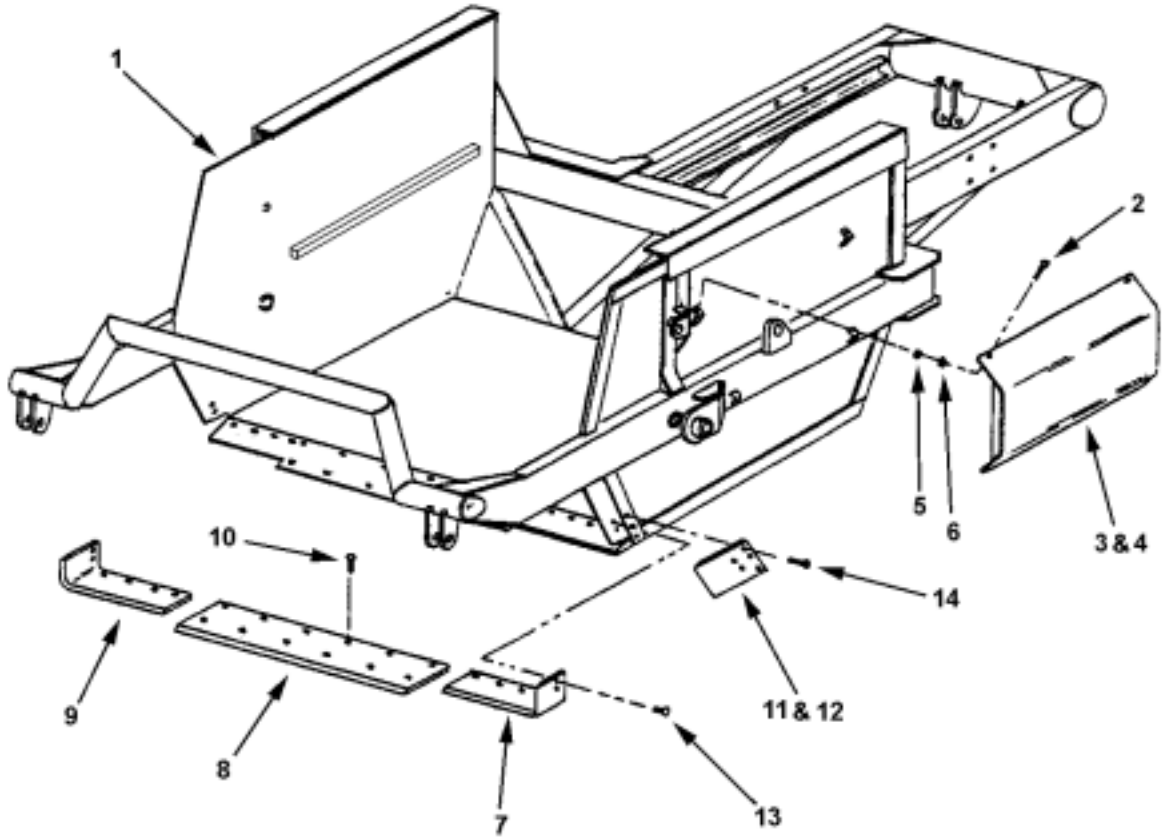

KEY NO.	PART NO.	DESCRIPTION
1		Bowl and Frame I-110 XL
2	6835	Bolt, 3/8" NC x 1"
3	A10157	Left hand cylinder guard
4	A10158	Right hand cylinder guard
5	8078	3/8" Lockwasher
6	7450	Nut, 3/8" NC
7	A123332L	Left cutting edge, 8"
8	A1233331	Center cutting edge, 12" x 54"
9	A123332R	Right cutting edge, 8"
10	PB9P-NC-088-0275	Plow bolt, 7/8" NC x 2-3/4" (12 req'd)
	AFN-00019	Nut: 7/8" NC (12 req'd.)
11	A123338L	(Optional) Left Bank Shaver Side Blade
12	A123338R	(Optional) Right Bank Shaver Side Blade
13	PB9P-NC-088-0275	Plow bolt, 7/8" NC x 2-3/4" (6 req'd / blade)
	AFN-00019	Nut: 7/8" NC (6 req'd / blade)
14	PB9P-NC-088-0275	Plow Bolt, 7/8" NC x 2-3/4" (4 req'd / blade)
	AFN-00019	Nut: 7/8" NC (4 req'd / blade)
	PB9P-NC-088-0225	Plow Bolt, 7/8" NC x 2-3/4" (3 req'd / blade)
	AFN-00026	Nut: 7/8" Jam (3 req'd./blade)

I-110 PUSHOFF GATE

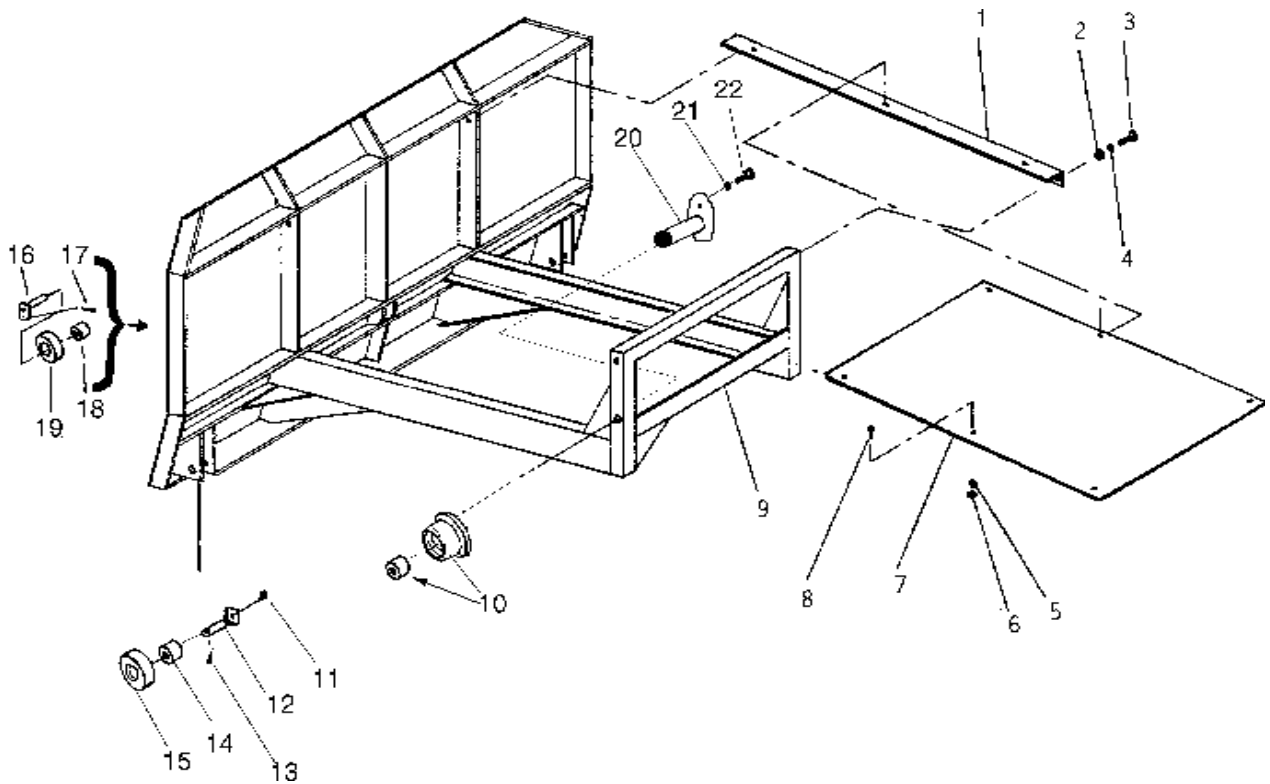

KEY NO.	PART NO.	DESCRIPTION
1	A10159	Brace, R. H. & L. H. same
2	AFN-00006	Nut, 3/4" NC
3	AFB-00037	Bolt, 3/4" NC x 2" lg.
4	AFW-00002	Lockwasher, 3/4"
5.	8078	Lockwasher: 3/8"
6.	7450	Nut: 3/8" NC
7.	A10171	Dirt Shield
8.	AFB-00034	Bolt: 3/8 NC x 1" Lg.
9	A10160	Pushoff Gate: I-110
10.	A123306	Roller: Rear Gate
	A123307	Bushing" 1-5/8" OD x 1-1/4" ID
11.	AHF-00028	Grease Fitting: 1/8" NPT -90 degree
12.	A6007A	Pin: 1-1/4" x 4-1/8" Lg.
13.	AFP-00001	Cotter Pin: 1/4 X 3-1/2"
14.	A10163	Bushing: 1-3/4" OD x 1-1/4" ID
15.	A10164	Roller: 4-1/4 OD X 1-3/4 ID
16.	A123288	Pin: 1-1/4 X 3-1/4" Tab Head
17.	7036	Bolt: 1/2 NC X 2"
18.	A10163	Bushing: 1-3/4" OD x 1-1/4" ID
19.	A10164	Roller: 4-1/4 OD X 1-3/4 ID
20.	A123305	Pin: 1-1/4 X 2-3/4"
21.	8100	Lockwasher: 1/2"
22.	AFB-00033	Bolt: 1/2 NC X 2-1/2"

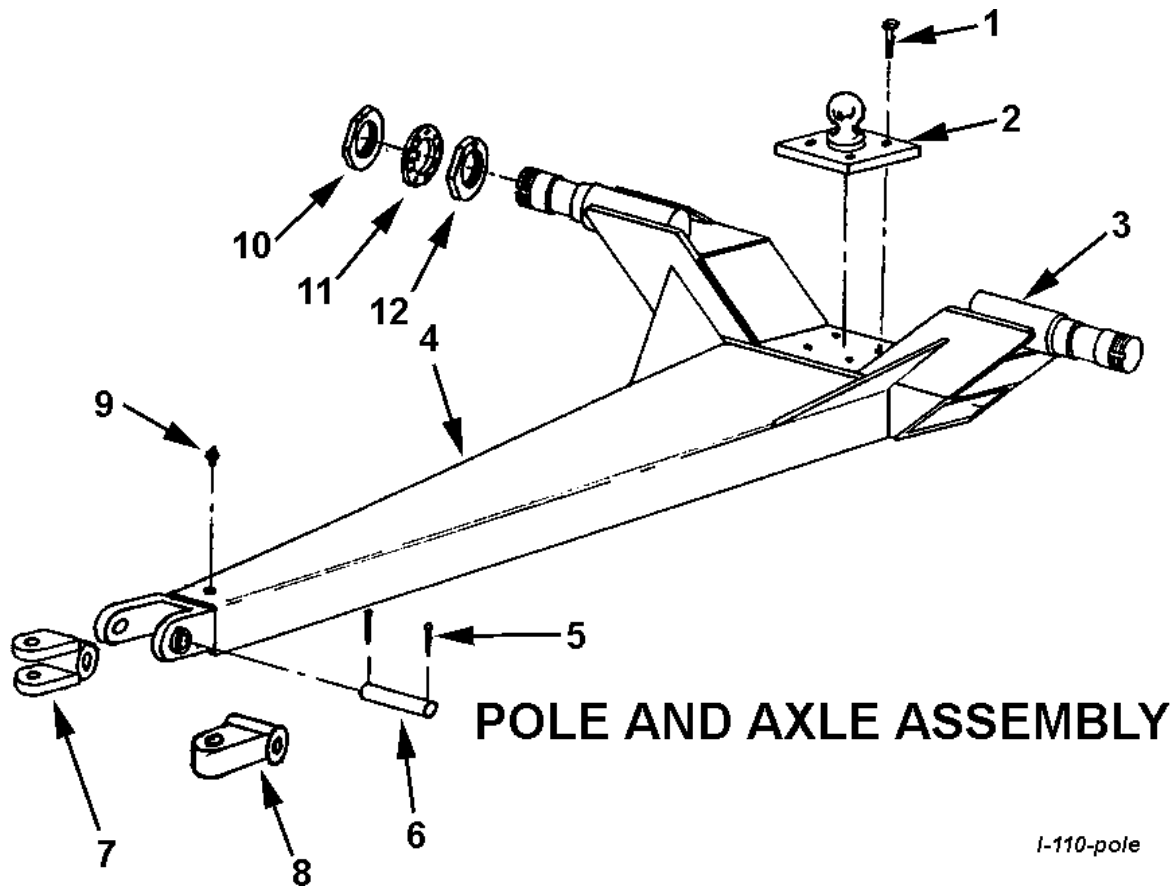

KEY NO.	PART NO.	DESCRIPTION
1	AFB-00005	Bolt, 3/4" NC x 2-1/2"
2	A10035	Ball swivel
3	A14021	Spindle Only Weldable, s/n 17844 & up
4	A10181	Pole, s/n 17844 & up
5		Cotter pin, 1/4" x 2-1/2" lg.
6	A10034	Pin, 1-1/2" x 6-1/4" lg.
7	A10033	Double lip clevis
8	A10033A	Single lip hitch
9	14505	Grease fitting
10	A10048	Spindle nut
11	A10049A	Lock collar
12	A10172	Nut w/ Lock pin

FRONT WHEEL AND HUB ASSEMBLY

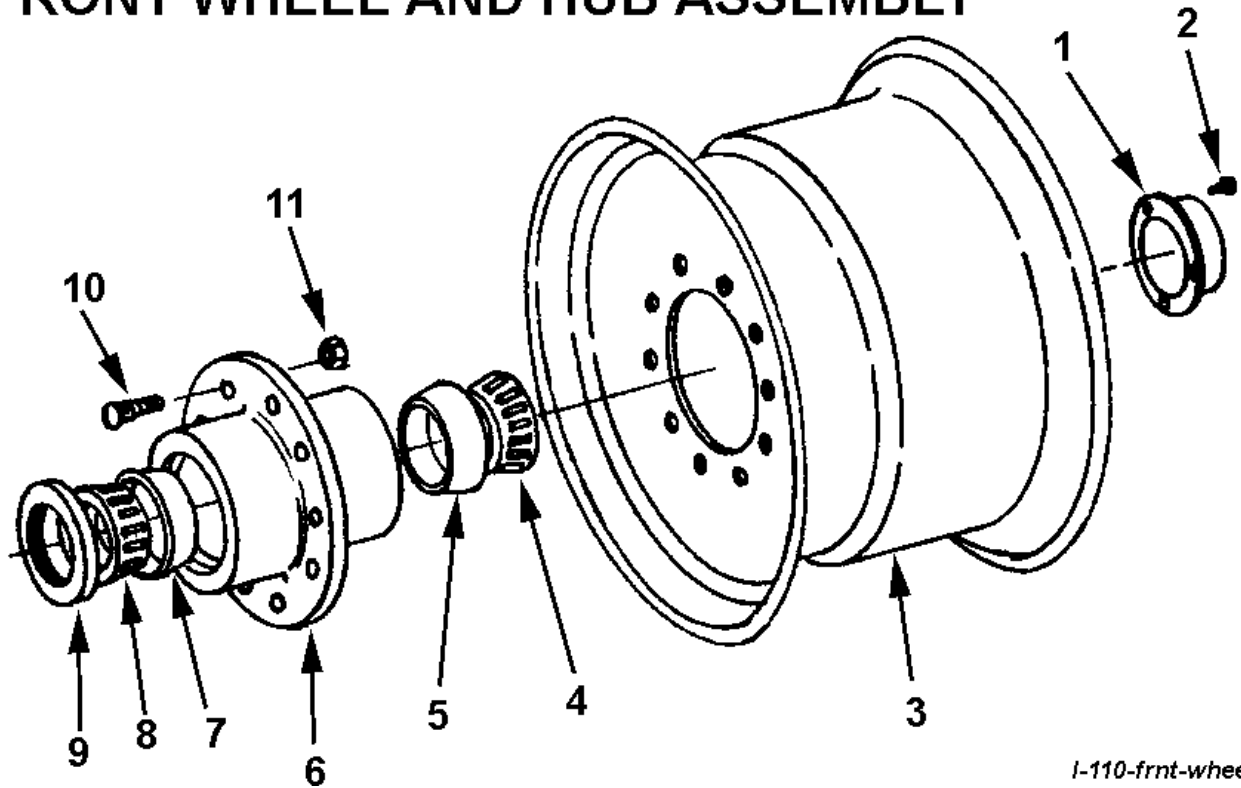

I-110-frnt-wheel

KEY NO.	PART NO.	DESCRIPTION
1	A14004	Hub cap
2	AFB-00026	Bolt, 5/16 NC x 5/8 lg.
3	A10170	Wheel, 14 x 16.1
4	A14015	Bearing cone (Timken 644)
5	A14014	Bearing cup (Timken 632)
6	A14010	Hub
7	A14013	Bearing cup (Timken 742)
8	A14012	Bearing cone (Timken 749)
9	A14011	Grease seal (CR 42624)
10	A10176	Stud
11	A10046	Lug nut

REAR WHEEL, SPINDLE & HUB ASSEMBLY

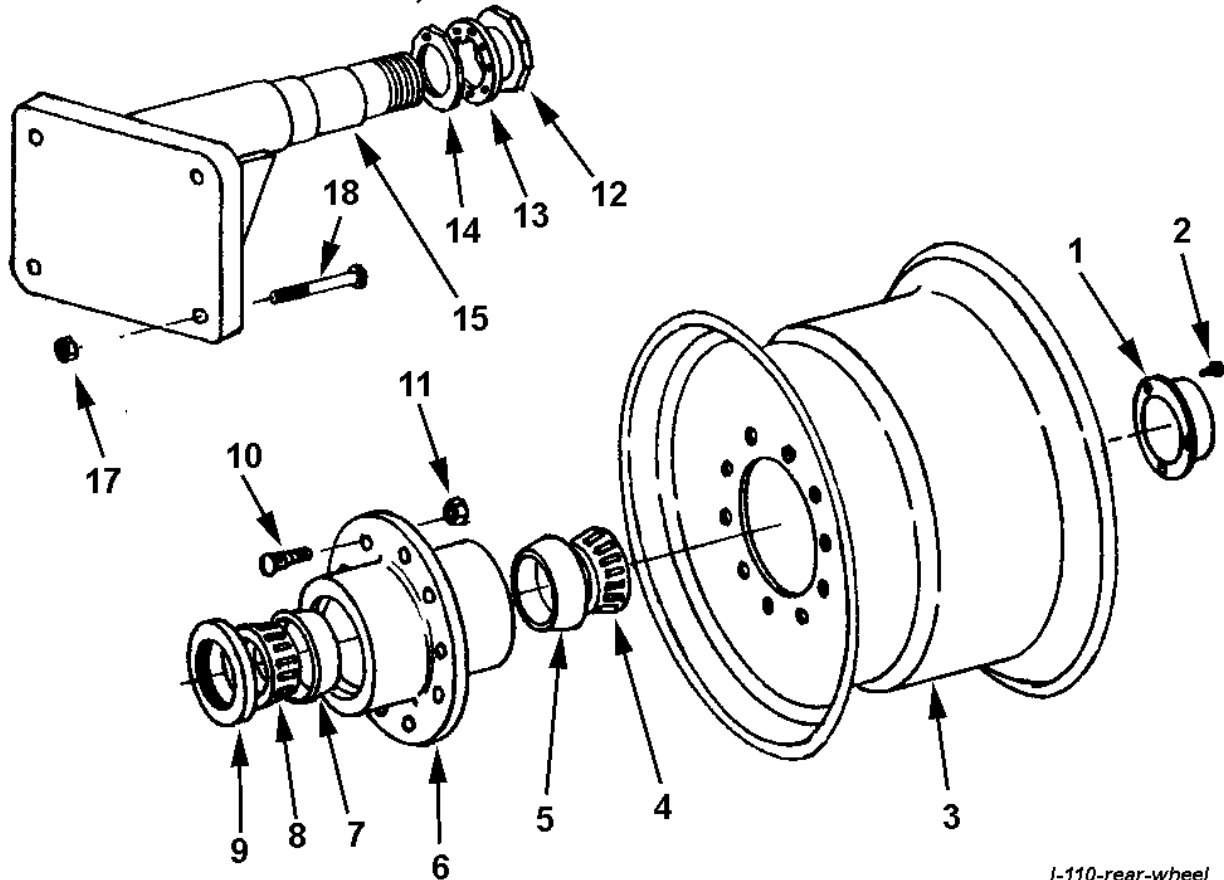

I-110-rear-wheel

KEY NO.	PART NO.	DESCRIPTION
1	A14004	Hub cap
2	AFB-00026	Bolt, 5/16 NC x 5/8 lg.
3	A10039	Wheel, 16 x 26 Drop Center
4	A14015	Bearing cone (Timken 644)
5	A14014	Bearing cup (Timken 632)
6	A14010	Hub
7	A14013	Bearing cup (Timken 742)
8	A14012	Bearing cone (Timken 749)
9	A14011	Grease seal (CR 42624)
10	A10176	Stud
11	A10046	Lug nut
12	A10048	Spindle nut
13	A10049A	Lock collar
14	A10172	Nut w/ lock pin
15	A14037	Spindle
17	AFN-00001	Nut: 1" NF Top Lock
18	AFB-00017	Bolt, 1" NF x 6-1/2" lg.

HYDRAULIC CYLINDER

4" x 13"
A123319

APRON CIRCUIT,

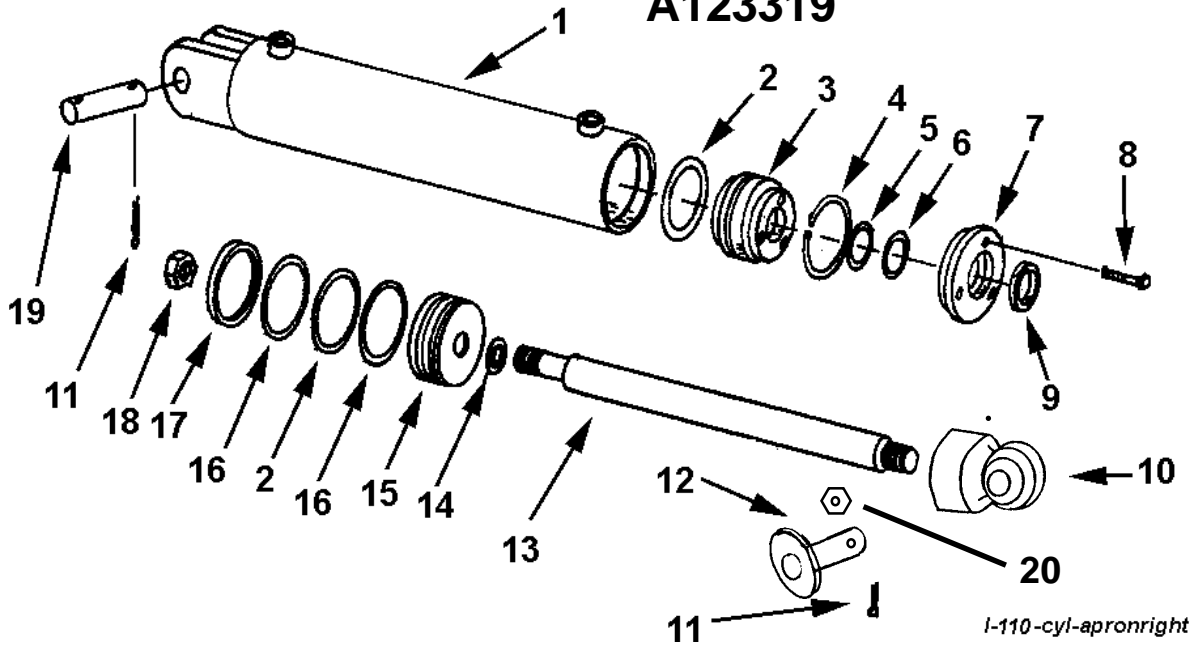

KEY NO.	PART NO.	DESCRIPTION
1	A175H01	Barrel Assembly
2	A300H06	O-ring seal, 4" OD x 3/16"
3	A300H11	Head gland
4	A300H12	Retainer ring
5	A22H15	O-ring, 1-1/2" x 1/8"
6	A22H15A	Backup washer
7	A300H13	Head cap
8	A22H18	Capscrew, 1/4 NC x 1"
9	A22H17	Wiper seal, 1-1/2" ID
10	A123345	Block type Apron Cyl. Rod end cyl. 1"
11	AFB-00015	HHCS: 1/2 NC x 1-1/2"
12	A123336	Pin: Tab Head w/Grease Fitting
13	A175H02	Shaft, 1-1/2" diameter
14	A45H05	Piston gasket, 1"
15	A300H07	Piston, 4" dia.
16	A300H05	Back up washer, 4" OD
17	A300H04	Cast iron ring, 4" OD
18	A300H03	Piston nut, 1" NF
19	A1217	Pin, 1" x 3-1/2"
20	7500	Nut: 1/2" NC
	A300H14B	Packing kit containing:
		1 - A300H04 2 - A22H15 2 - A300H05
		1 - A22H15A 2 - A22H06 1 - A22H17
		1 - A45H05

HYDRAULIC CYLINDER DIG AND LIFT CIRCUIT

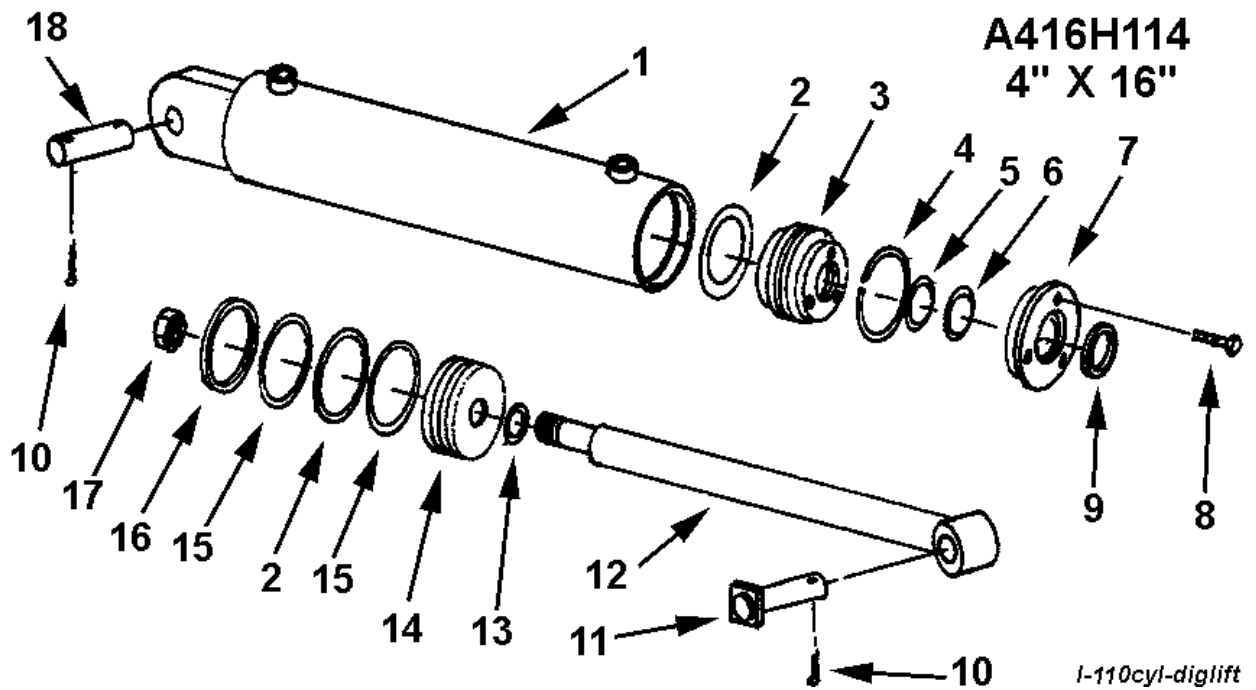

KEY NO.	PART NO.	DESCRIPTION
1	A45H04	Barrel Assembly
2	A300H06	O-ring, 4" OD x 3/16"
3	A300H11	Head gland
4	A300H12	Retainer ring
5	A22H15	O-ring, 1-1/2" ID x 1/8"
6	A22H15A	Backup washer
7	A300H13	Head cap
8	A22H18	Capscrew, 1/4" x 1"
9	A22H17	Wiper seal, 1-1/2" ID
10	AFP-00002	Cotter pin, 3/16" x 1-3/4"
11	A6007A	Pin, 1-1/4" X 4-1/8" w/ square head
12	A45H03	Shaft, 1-1/2" diameter
13	A45H05	Piston gasket, 1" ID
14	A300H07	Piston, 4"
15	A300H05	Backup washer, 4" OD
16	A300H04	Cast iron ring, 4" OD
17	A300H03	Piston nut
18	A45003	Pin, 1-1/8" x 3-1/4"
	A300H14B	Packing kit containing:
		1 - A300H04 2 - A22H15 2 - A300H05
		1 - A22H15A 2 - A300H06 1 - A22H17
		1 - A45H05

I-110 PUSH GATE CYLINDER ASSEMBLY PART NO. A454H114B

4" BORE X 54" STROKE - MODEL I-110 (SERIAL NO. 17661 & UP)

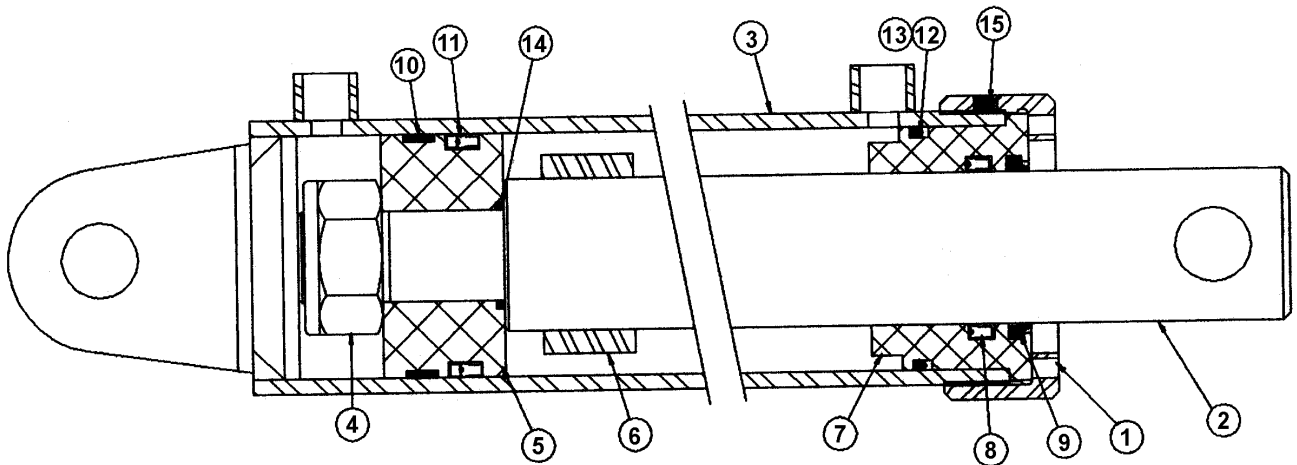

I-110-cyl-push

KEY NO.	QTY.	PART NO.	DESCRIPTION
1	1	A101H103	Collar
2	1	A101H98	2 1/2" Rod
3	1	A101H97	Barrel weldment
4	1	AFN-00018	Lock nut (1-1/2" - 12)
5	1	A101H96	Piston
6	1	A101H99	Spacer
7	1	A101H102	Head
8	1	A140H07	Rod seal
9	1	A140H08	Rod wiper
10	1	A101H100	Wear ring
11	1	A101H101	Piston seal
12	1	A200H06	O-ring
13	1	A300H05	Backup ring
14	1	A22H15	O-ring
15	1		Nylon tip set screw (3/8" NC x 3/8)
16	1	A101H30A	Seal kit (Items 8-14)

SEQUENCE VALVE

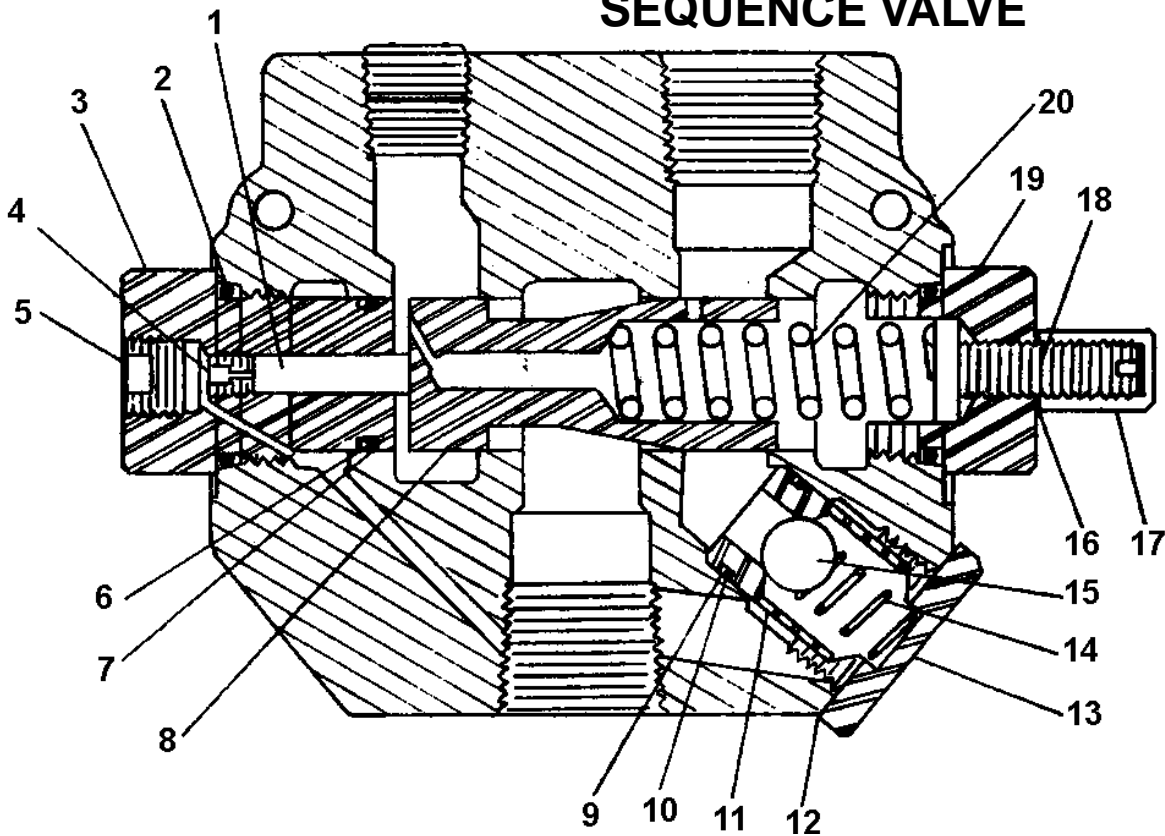

KEY NO.	PART NO.	DESCRIPTION
1	A101H49	Piston
2	A101H50	O-ring
3	A101H51	External pilot plug
4	A101H52	Orifice
5	A101H53	Plug
6	A101H54	O-ring
7	A101H55	Backup washer
*8	A101H70	Metering spool
9	A101H57	Backup washer
10	A101H58	O-ring
11	A101H59	Check seat
12	A101H60	Aluminum washer
13	A101H61	Check plug
14	A101H62	Check spring
15	A101H63	Check ball
16	A101H64	Aluminum washer
17	A101H65	Acorn nut
18	A101H66	Adjusting screw
19	A101H69	Adjusting plug - RD1075 SM
20	A101H68	Metering spring
*	A101H71	Valve body

* NOT SOLD SEPARATELY

SEQUENCE VALVE

The sequence valve controls two hydraulic circuits with one hydraulic remote. Ashland Industries incorporates a sequence valve to control the Apron and Pushoff cylinder systems. When the tractor's hydraulic remote is activated, oil flows first to the apron cylinders until they are fully extended. Once the cylinders are fully extended, the apron circuit's hydraulic pressure begins to increase. Once the pressure threshold is surpassed (which is adjustable. See adjustment section), the sequence valve diverts the oil flow to the pushoff's hydraulic circuit. Once the pushoff is completely extended the operator then reverses the tractor's hydraulic remote. This will direct oil first to the Apron circuit. Once the apron cylinders are fully retracted, again the hydraulic pressure begins to increase allowing the pushoff to retract fully once the oil has been diverted from the sequence valve.

INSTRUCTIONS for establishing sequence valve setting:

Remove acorn nut from end of sequence valve with a 1/2" wrench. Turn adjustment screw, using a 4mm hex wrench, clockwise until front apron rises before the push-off advances while the earthmover is empty. Turn the adjustment screw an additional 1/4 turn clockwise, then replace the acorn nut and tighten. Torque check valve assembly and internal pilot plug to 25 ft.-lbs. maximum.

Limited Warranty Statement

Ashland Industries Inc. warrants each new product to be free from defects in material and workmanship. This warranty is applicable only for the normal service life expectancy of the product or components, not to exceed six consecutive months from the date of delivery of the new Ashland Industries product to the original purchaser, or the date the product is first put into service via a rental agreement or other means, whichever occurs first.

Genuine Ashland Industries Inc. replacement parts and components will be warranted for 30 days from date of purchase, or the remainder of the original equipment warranty period, whichever is longer.

Under no circumstances will it cover any merchandise or components thereof, which in the opinion of the company, has been subjected to misuse, unauthorized modification, alterations, an accident or if repairs have been made with parts other than those obtained through Ashland Industries Inc.

Ashland Industries Inc. in no way warrants Tires since these items are warranted separately by their respective manufacturer. Please call Ashland Industries Inc. to receive phone numbers of tire suppliers.

Ashland Industries Inc. in no way warrants wearable items such as cutting edges, front dolly wheel balls, socket halves.

Our obligation under this warranty shall be limited to repairing or replacing, free of charge to the original purchaser, any part that, in our judgement, shall show evidence of such defect, provided further that such part shall be returned within 30 days from the date of failure to Ashland Industries Inc. routed through the dealer and distributor from whom the purchase was made, transportation charges prepaid. Upon warranty approval proper credits will be reimbursed for transportation.

This warranty shall not be interpreted to render Ashland Industries Inc. liable for injury or damages of any kind or nature to person or property. This warranty does not extend to the loss revenue, extra labor cost associated with downtime, substitute machinery, rental or for any other reason.

Except as set forth above, Ashland Industries Inc. shall have no obligation or liability of any kind on account of any of its equipment and shall not be liable for special or consequential damages. Ashland Industries Inc. make no other warranty, expressed or implied, and, specifically, Ashland Industries Inc. disclaims any implied warrant or merchantability or fitness for a particular purpose. Some states or provinces do not permit limitations or exclusions of implied warranties or incidental or consequential damages, so the limitations or exclusion in this warranty may not apply.

This warranty is subject to any existing conditions of supply which may direct affect our ability to obtain materials or manufacture replacement parts.

Ashland Industries Inc. reserves the right to make improvements in design or changes in specifications at any time, without incurring any obligation to owners of units previously sold

No one is authorized to alter, Modify or enlarge this warranty nor the exclusion, limitations and reservations.

Ashland Industries Inc.
Warranty Department