

8 7 6 5 4 3 2 1

D  
C  
B  
A

D  
C  
B  
A

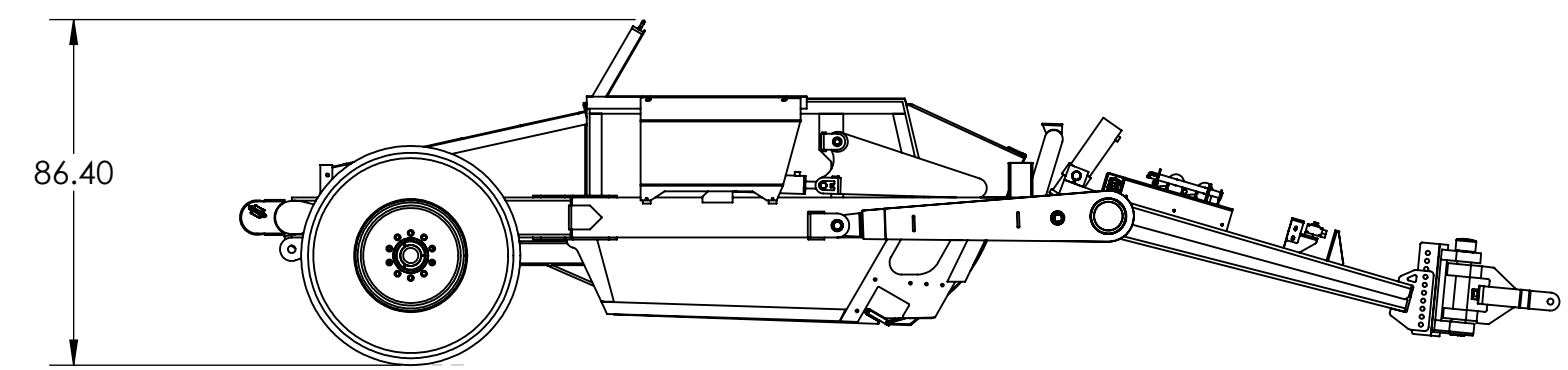
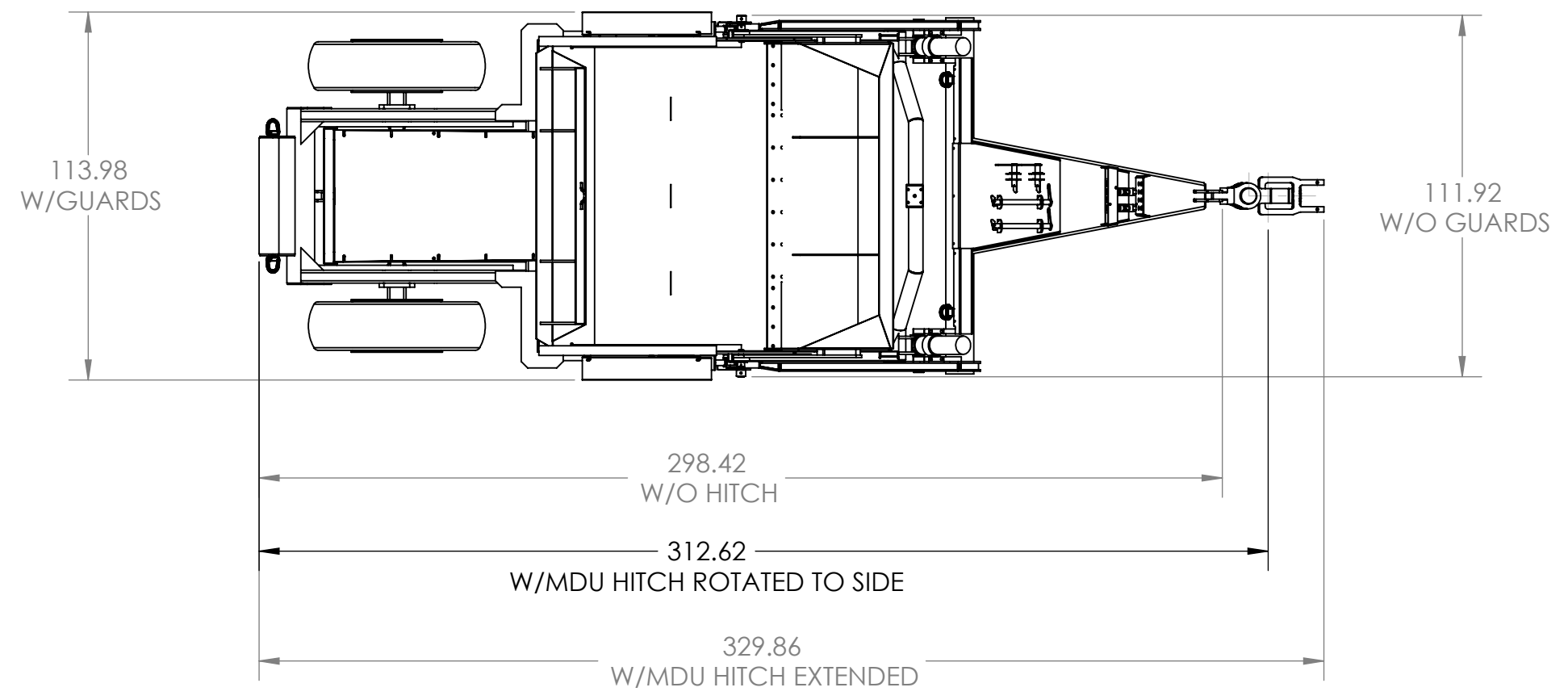

UNLESS OTHERWISE SPECIFIED:  
 DIMENSIONS ARE IN INCHES  
 TOLERANCES:  
 FRACTIONAL  $\pm 1/64$   
 ANGULAR: MACH  $\pm 1^\circ$   
 BEND  $\pm 3^\circ$   
 TWO PLACE DECIMAL  $\pm .010$   
 THREE PLACE DECIMAL  $\pm .005$   
**NOTE:** BREAK ALL SHARP EDGES  
 & CORNERS  
 MATERIAL  
 FINISH  
 DO NOT SCALE DRAWING

|         | NAME | DATE |
|---------|------|------|
| DRAWN   |      |      |
| CHECKED |      |      |
|         |      |      |
|         |      |      |

**PROPRIETARY AND CONFIDENTIAL**  
 THE INFORMATION CONTAINED IN THIS  
 DRAWING IS THE SOLE PROPERTY OF  
 ASHLAND INDUSTRIES, INC. ANY  
 REPRODUCTION IN PART OR AS A WHOLE  
 WITHOUT THE WRITTEN PERMISSION OF  
 ASHLAND INDUSTRIES, INC. IS  
 PROHIBITED.

|   |          |     |
|---|----------|-----|
| <b>ASHLAND INDUSTRIES, INC.</b><br>1115 RAIL DRIVE<br>ASHLAND WISCONSIN<br>www.ashlandind.com |          |     |
| TITLE:  |          |     |
| <b>TS 110/130 CE Machine</b>  |          |     |
| SIZE  | DWG. NO. | REV |
| <b>B</b>  | 700015   |     |
| SCALE: 1:48 WEIGHT: 11915.53 3920755 OF 1   |          |     |

8 7 6 5 4 3 2 1